

## MAX77751 Evaluation Kit

Evaluates: MAX77751

### General Description

The MAX77751 evaluation kit (EV kit) is a fully assembled and tested printed circuit board (PCB) that demonstrates the MAX77751, the standalone 3.15A USB Type-C® autonomous charger.

The EV kit is a switch-mode charger and Smart Power Selector™ with autonomous configuration. The MAX77751 can operate from 4.5V to 14V input, with the fast-charge current up to 3.15A and maximum input current limit of 3A.

The EV kit features USB Type-C CC detection, battery charging compliant with the USB Battery Charging Specification Revision 1.2 (BC1.2), proprietary adapter detection upon input insertion, and automatic configuration of the charger input current limit to the maximum allowable current from the input source.

The MAX77751 has the reverse-boost capability, which is enabled by the ENBST pin to allow the 5.1V/1.5A output to CHGIN.

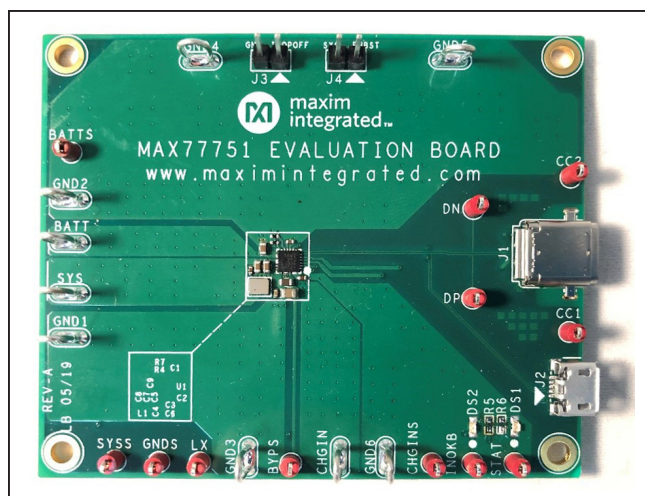

Figure 1. MAX77751 EV Kit Photo

### Benefits and Features

- Up to 16V Protection
- 14V Maximum Input Operating Voltage
- 3.15A Maximum Charging Current
- 6A Discharge Current Protection
- No Firmware or Communication Required
- Integrated USB Detection
  - Integrated CC Detection for USB Type-C
  - Integrated BC1.2 Detection for Legacy SDP, DCP, and CDP
  - Automatic Input Current Limit Configuration
- Input Voltage Regulation with Adaptive Input Current Limit (AICL)
- Reverse-Boost Capability up to 5.1V, 1.5A
- Pin Control of All Functions
  - Resistor-Configurable Fast-Charge Current
  - Resistor-Configurable Top-off Current
  - ENBST Pin to Enable and Disable Reverse Boost
  - STAT Pin to Indicate Charging Status
  - INOKB Pin to Indicate Input Power-OK (POK)
  - ITOPOFF Pin to Disable Charge
- Integrated Power Path
- Integrated Battery True-Disconnect FET
- Proven PCB Layout
- Fully Assembled and Tested

[Ordering Information](#) appears at end of data sheet.

USB Type-C and USB-C are registered trademarks of USB Implementers Forum.  
Smart Power Selector is a trademark of Maxim Integrated Products, Inc.

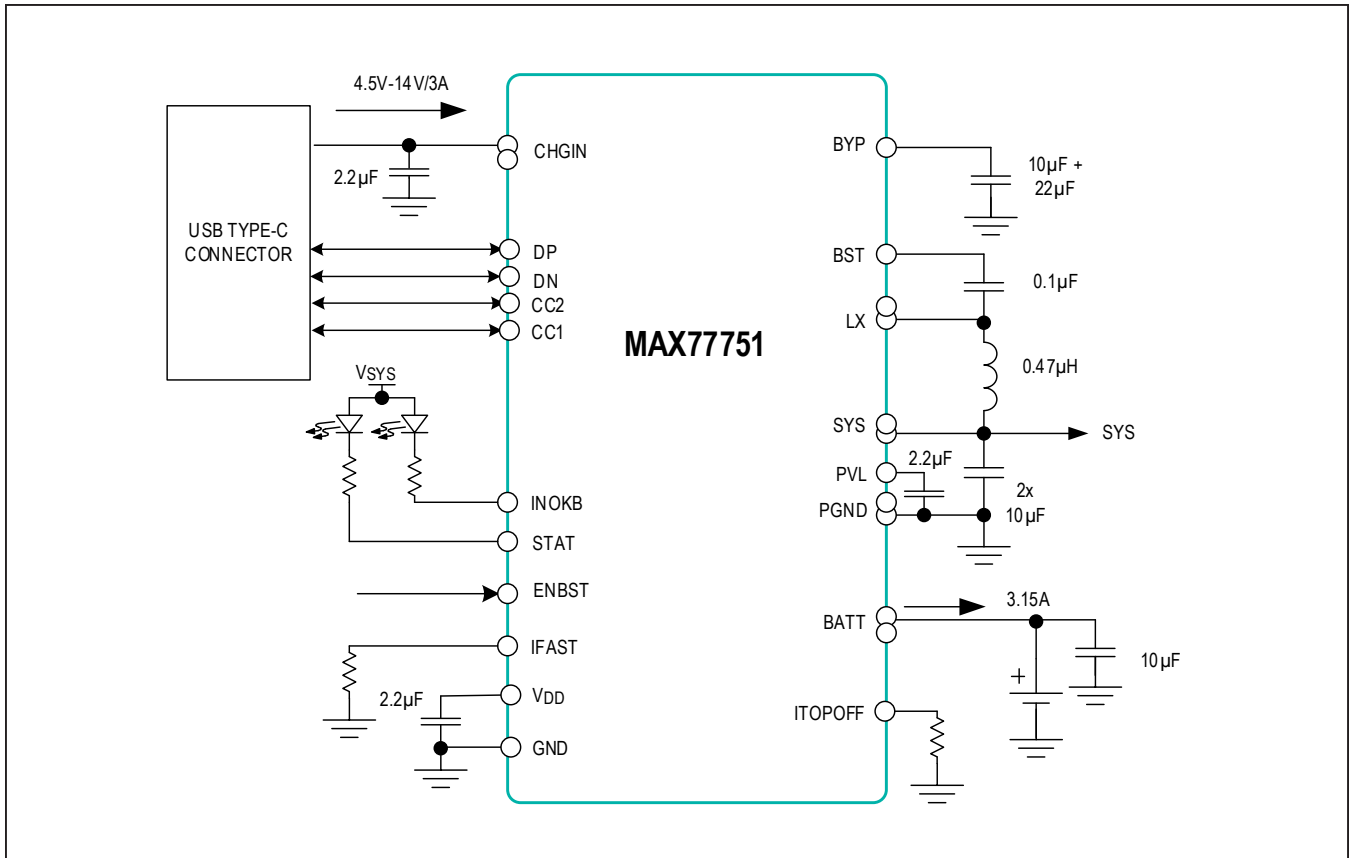

Figure 2. Simplified Block Diagram

### Quick Start

#### Required Equipment

- MAX77751 evaluation kit
- USB Type-C travel adapter and cable
- Power supply
- Battery/battery simulator/power supply with electronic load
- Oscilloscope
- Multi-meters

#### Initial Test Setup

The EV kit is fully assembled and tested. Follow the steps below to verify board operation:

- 1) Do not turn on the DC power supplies until all connections are made.
- 2) Confirm all jumpers are at their default positions as indicated in [Table 1](#) (J3 Open, J4 Open).
- 3) Connect the battery/battery simulator/power supply to the loop labeled BATT and GND.
- 4) Connect the power supply to the loop labeled CHGIN.
- 5) The EV kit is now ready for use.

### Detailed Description of Hardware

Follow the initial test setup procedure.

#### Battery Charger Test Setup

The battery charger can be tested in three different ways with a battery, battery simulator, or power supply with electronic load.

##### Battery

- 1) Connect the 1 cell battery pack and current meter between BATT and GND. Note: Only use a battery with a charge termination voltage that matches that of the MAX77751 populated on the board.
- 2) Connect the 5.0V/5.0A current-limited DC power supply between CHGIN and GND and turn it on.
- 3) Observe the current reading from the current meter. If the battery is discharged, the fast-charging current should match the setting with the external IFAST resistor (R4).

##### Battery Simulator

- 1) Connect the battery simulator between BATT and GND, adjust the voltage to 3.8V with 3.5A current limit, and turn it on.

### Table 1. Default Shunt Positions and Jumper Descriptions

JUMPER #	DEFAULT POSITION	FUNCTION
J3	Open	1-2 Disable Charger
J4	Open	1-2 Enable the Reverse Boost

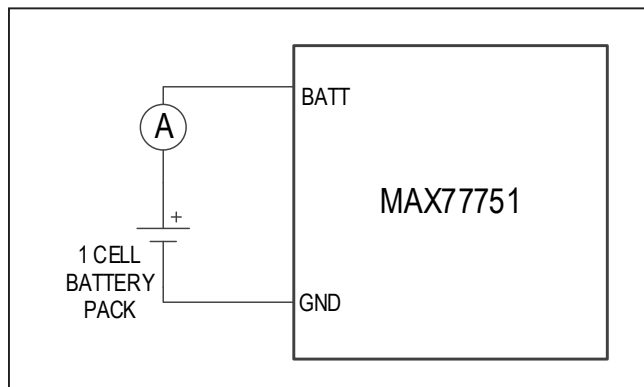

Figure 3. Battery Charger Test with Real Battery Pack

- 2) Connect the 5.0V/5.0A current-limited DC power supply between CHGIN and GND and turn it on.
- 3) Observe the current reading from the battery simulator and see if the fast-charging current matches with the external IFAST resistor.

#### Power Supply with Electronic Load

- 1) Connect the power supply between BATT and GND and adjust the voltage to 3.8V with 3.5A current limit.
- 2) Connect the electronic load between BATT and GND and set the load current to 3.5A.
- 3) Turn on the power supply and electronic load.
- 4) Connect the 5.0V/5.0A current-limited DC power supply between CHGIN and GND and turn it on.
- 5) Observe the current reading from the current meter 1 and 2 (the fast-charging current equals  $I_1 - I_2$ ) and see if this value matches with the external IFAST resistor.

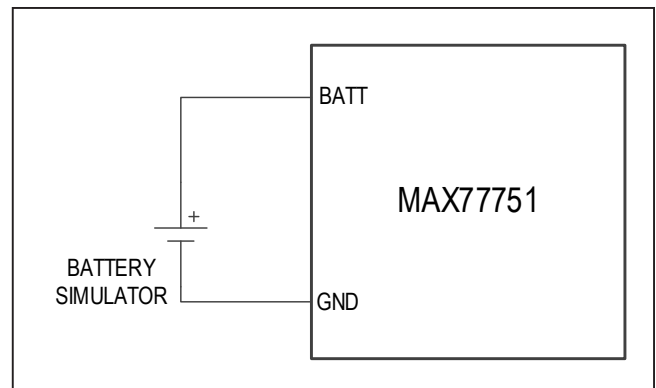

Figure 4. Battery Charger Test with Battery Simulator

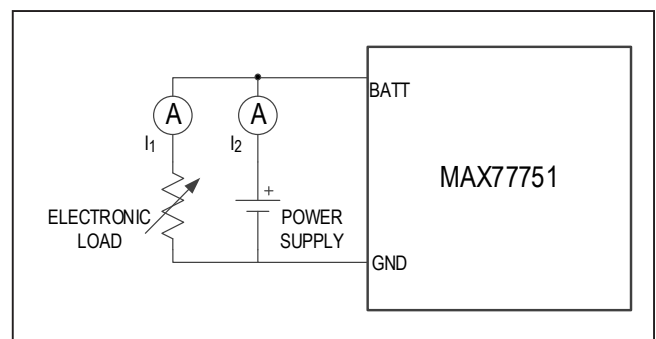

Figure 5. Battery Charger Test with Power Supply and Electronic Load

**BC1.2 and CC Detection Test Setup**

- 1) Connect the battery/battery simulator/power supply with electronic load between BATT and GND. See the Battery Charger Test Setup section for details.
- 2) Plug in the USB Type-C cable from the PC or AC adaptor
- 3) Check if the MAX77751 configures the input current limit correctly.

**Reverse Boost Test Setup**

- 1) Connect the power supply between BATT and GND, adjust the voltage to 3.8V with 3.5A current limit, and turn it on.
- 2) Apply the Jumper 4 to enable the reverse-boost mode.

- 3) Monitor the voltage of CHGIN and see whether it equals 5.1V.

**LED Indicator**

- 1) Two LED indicators are installed on the EV kit: DS1 (Green) is for the STAT pin and DS2 (Red) is for INOKB.
- 2) The STAT pin is an open-drain and active low output that indicates charge status. See [Table 2](#) for details.
- 3) INOKB is an open-drain and active low output that indicates the input status. If a valid input source is inserted and the buck converter starts switching, INOKB pulls low. When the reverse boost is enabled, INOKB pulls low to indicate the 5V output from CHGIN.

**Table 2. STAT Output with Charging Status**

CHARGING STATUS	STAT	LOGIC STATE	CHARGE STATUS LED
No Input	High Impedance	High	OFF
Trickle, Precharge, Fast Charge	Repeat Low and High Impedance with 1Hz, 50% duty cycle	After an external diode and a capacitor rectifier, High	Blinking with 1Hz, 50% duty cycle.
Top-Off and Done	Low	Low	Solid ON
Faults	High Impedance	High	OFF

**Component Suppliers**

SUPPLIER	PHONE	WEBSITE
MURATA	770-436-1300	www.murata-northamerica.com
SAMTEC	800-726-8329	www.samtec.com
TAIYO-YUDEN	603-669-7587	www.t-yuden.com
TDK	847-803-6100	www.comopnent.tdk.com
VISHAY	408-970-5852	www.vishay.com
CYNTEC	510-668-5167	www.cyntec.com
PANASONIC	800-344-2112	www.panasonic.com

Note: Indicate that you are using the MAX77751 when contacting these component suppliers.

**Ordering Information**

PART NUMBER	IC	BATTERY TERMINATION VOLTAGE
MAX77751CEVKIT#	MAX77751CEFG+	4.20V
MAX77751FEVKIT#	MAX77751FEFG+	4.35V

## MAX77751 EV Kit Bill of Materials

QTY	REF DES	MAXINV	MFG PART #	MANUFACTURER	VALUE
6	BATT, CHGIN, GND1-GND3, SYS	01-9020BUSS20AWG-00	9020 BUSS	WEICO WIRE	MAXIMPAD
12	BATTS, BYPS, CC1, CC2, CHGINS, DN, DP, GNDS, INOKB, LX, STAT, SYSS	02-TPMINI5000-00	5000	KEYSTONE	N/A
2	C1, C8	20-002U2-A25	C1005X5R1A225K050BC	TDK	2.2UF
1	C2	20-002U2-33B	EMK105ABJ225MV; GRM155R61C225ME11	TAIYO YUDEN;KEMET	2.2UF
1	C3	20-0010U-B78	C1608JB1C106M080AB	TDK	10UF
1	C4	20-000U1-E2A	GRM155R61C104KA88	MURATA	0.1UF
3	C5, C7, C9	20-0010U-16	C1608X5R1A106K080AC	TDK	10UF
1	C6	20-0022U-23	N/A	N/A	22UF
1	DS1	30-LTSTC190GKT-00	LTST-C190GKT	LITE-ON ELECTRONICS INC.	LTST-C190GKT
1	DS2	30-LTSTC190EKT-00	LTST-C190EKT	LITE-ON ELECTRONICS INC.	LTST-C190EKT
1	J1	01-898430249031000024P-26	898-43-024-90-310000	MILL-MAX	898-43-024-90- 310000
1	J2	01-101181930001LF5P-26	10118193-0001LF	FCI CONNECT	10118193- 0001LF
2	J3, J4	01-TSW10207TS2P-17	TSW-102-07-T-S	SAMTEC	TSW-102-07- T-S
1	L1	00-SAMPLE-01	HTGH25201T-R47MSR-68	CYNTEC	HTGH25201T- R47MSR-68
1	R4	80-024K9-18	ERJ-2RKF2492	PANASONIC	24.9K
2	R5, R6	80-0470R-23	CRCW0402470RFK	VISHAY DALE	470
1	R7	80-08K06-18	ERJ-2RKF8061	PANASONIC	8.06K
1	U1	00-SAMPLE-02	MAX77751	MAXIM	MAX77751
1	PCB	EPCB77751SOLDEDRODOWN	MAX77751SOLDEDRODOWN	MAXIM	PCB

MAX77751 EV Kit Schematic

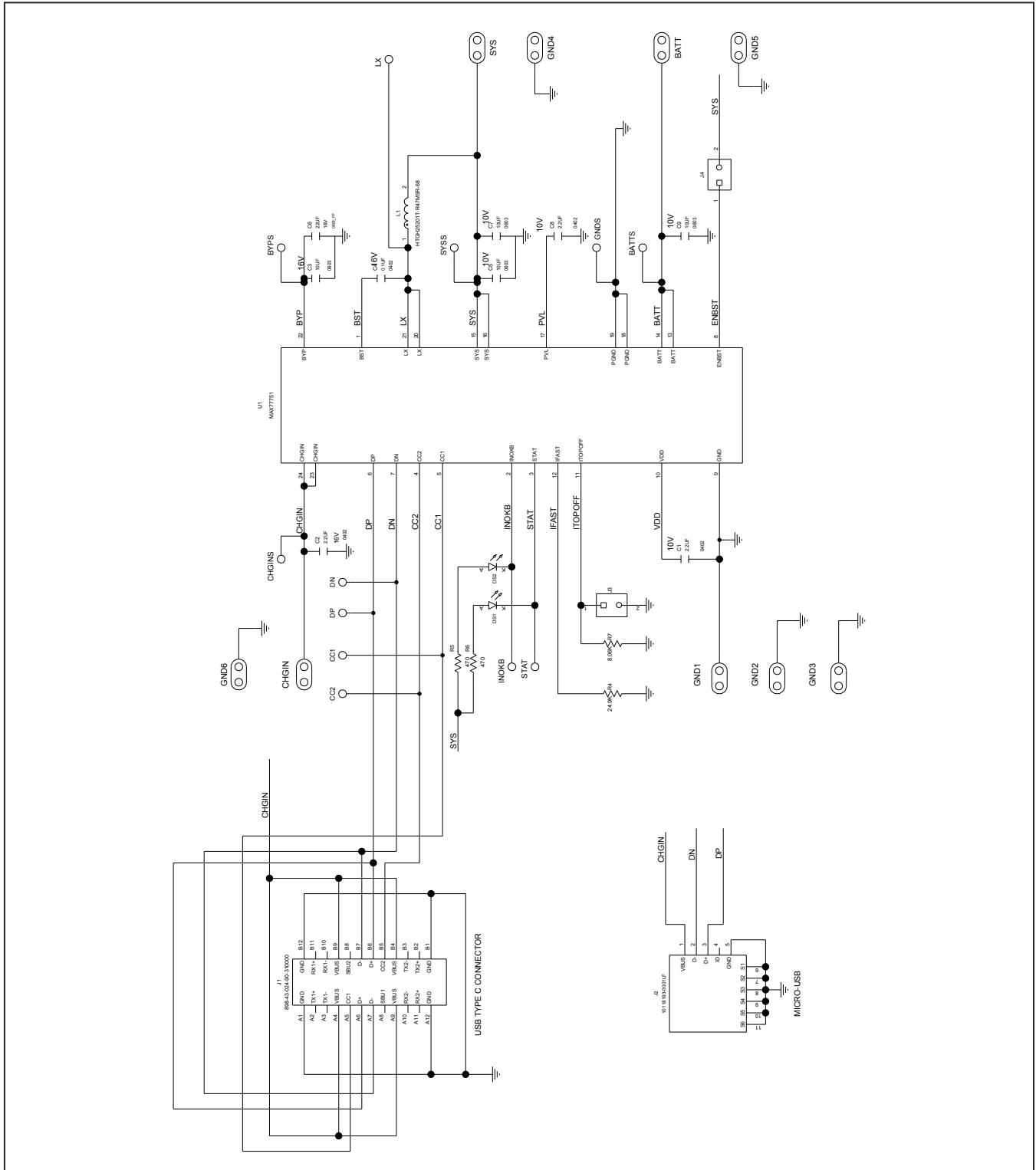

MAX77751 EV Kit PCB Layout

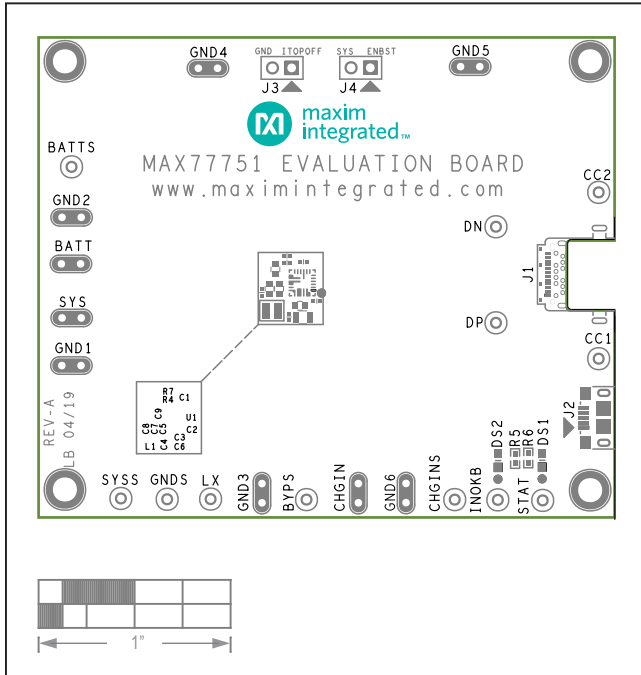

Silk Top

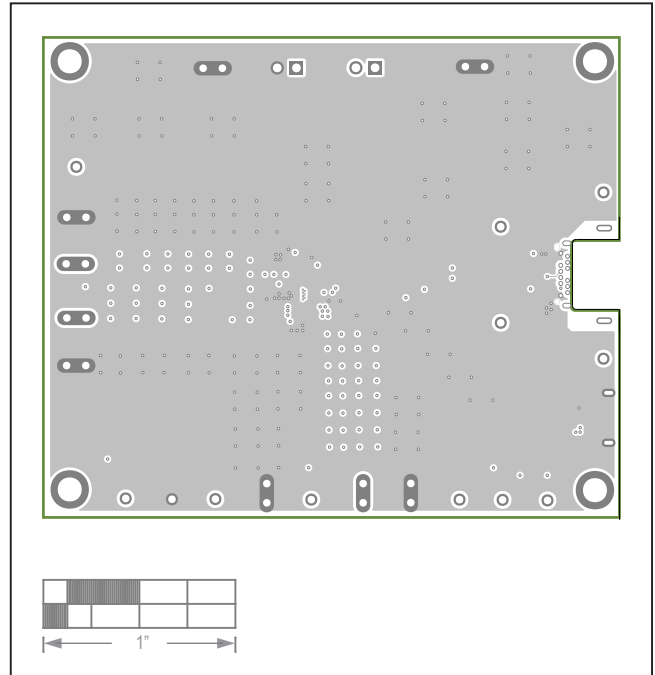

Internal2

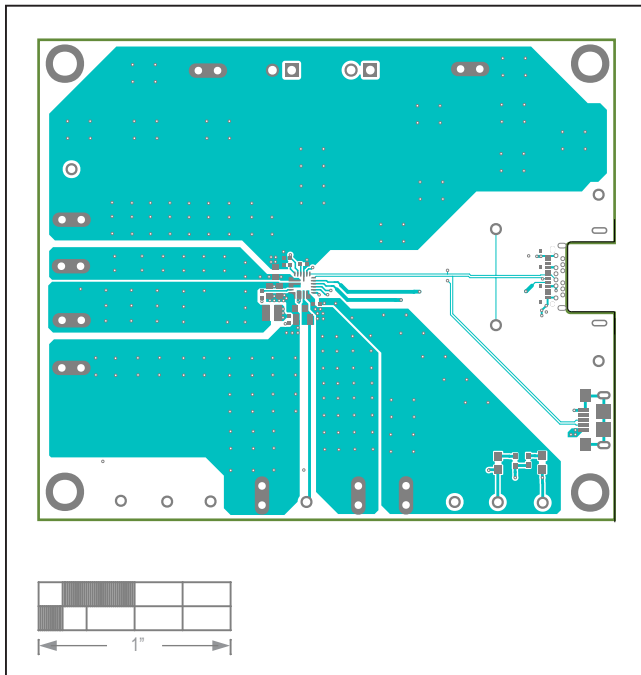

Top

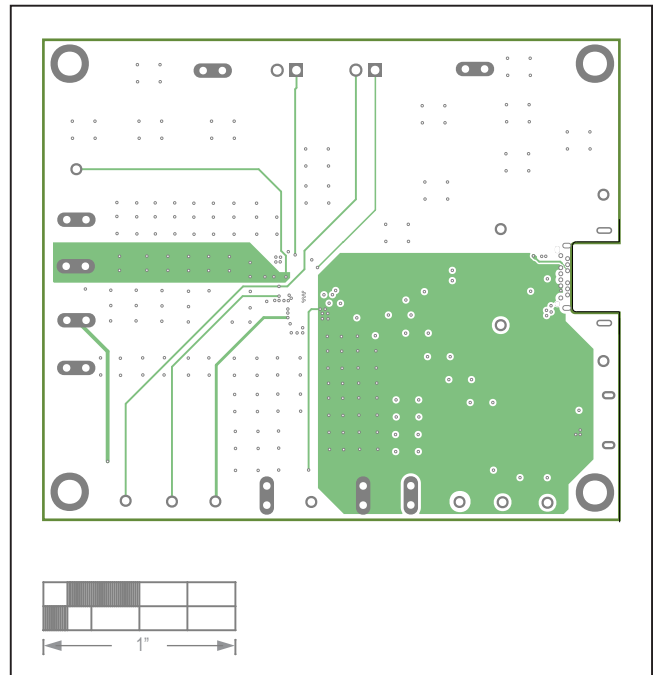

Internal3

MAX77751 EV Kit PCB Layout (continued)

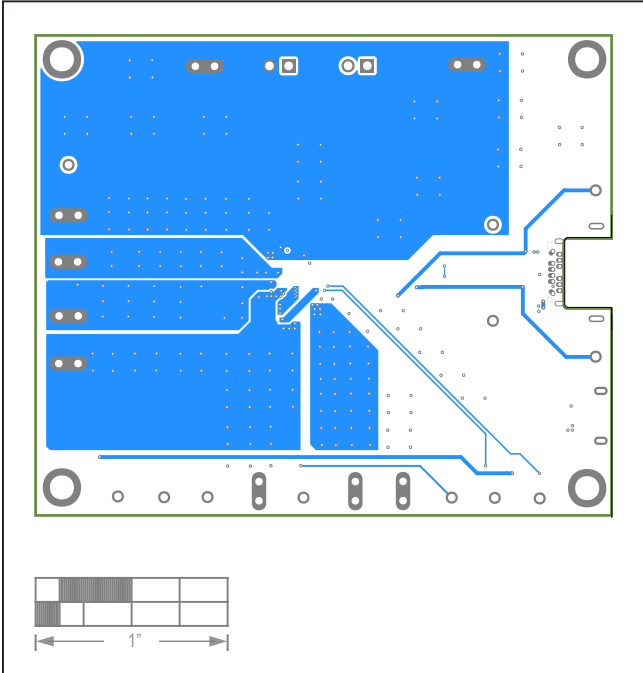

Bottom

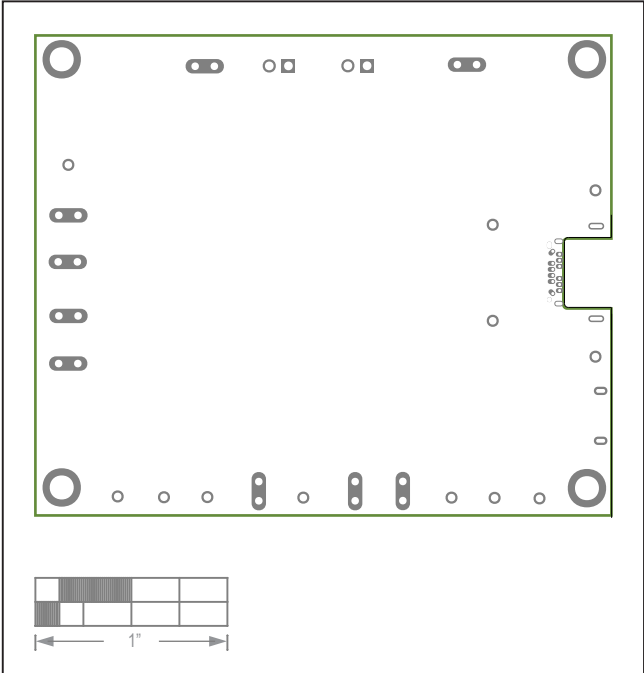

Silk Bottom



## Revision History

REVISION NUMBER	REVISION DATE	DESCRIPTION	PAGES CHANGED
0	5/20	Initial release	—
1	7/20	Updated the <i>Ordering Information</i>	4
2	9/20	Updated the <i>Ordering Information</i>	4

For pricing, delivery, and ordering information, please visit Maxim Integrated's online storefront at <https://www.maximintegrated.com/en/storefront/storefront.html>.

*Maxim Integrated cannot assume responsibility for use of any circuitry other than circuitry entirely embodied in a Maxim Integrated product. No circuit patent licenses are implied. Maxim Integrated reserves the right to change the circuitry and specifications without notice at any time.*

## X-ON Electronics

Largest Supplier of Electrical and Electronic Components

*Click to view similar products for [Power Management IC Development Tools](#) category:*

*Click to view products by [Maxim](#) manufacturer:*

Other Similar products are found below :

[EVB-EP5348UI](#) [MIC23451-AAAYFL EV](#) [MIC5281YMME EV](#) [124352-HMC860LP3E](#) [DA9063-EVAL](#) [ADP122-3.3-EVALZ](#) [ADP130-0.8-EVALZ](#) [ADP130-1.8-EVALZ](#) [ADP1740-1.5-EVALZ](#) [ADP1870-0.3-EVALZ](#) [ADP1874-0.3-EVALZ](#) [ADP199CB-EVALZ](#) [ADP2102-1.25-EVALZ](#) [ADP2102-1.875EVALZ](#) [ADP2102-1.8-EVALZ](#) [ADP2102-2-EVALZ](#) [ADP2102-3-EVALZ](#) [ADP2102-4-EVALZ](#) [AS3606-DB](#) [BQ25010EVM](#) [BQ3055EVM](#) [ISLUSBI2CKIT1Z](#) [LP38512TS-1.8EV](#) [EVAL-ADM1186-1MBZ](#) [EVAL-ADM1186-2MBZ](#) [ADP122UJZ-REDYKIT](#) [ADP166Z-REDYKIT](#) [ADP170-1.8-EVALZ](#) [ADP171-EVALZ](#) [ADP1853-EVALZ](#) [ADP1873-0.3-EVALZ](#) [ADP198CP-EVALZ](#) [ADP2102-1.0-EVALZ](#) [ADP2102-1-EVALZ](#) [ADP2107-1.8-EVALZ](#) [ADP5020CP-EVALZ](#) [CC-ACC-DBMX-51](#) [ATPL230A-EK](#) [MIC23250-S4YMT EV](#) [MIC26603YJL EV](#) [MIC33050-SYHL EV](#) [TPS60100EVM-131](#) [TPS65010EVM-230](#) [TPS71933-28EVM-213](#) [TPS72728YFFEVM-407](#) [TPS79318YEQEVM](#) [UCC28810EVM-002](#) [XILINXPWR-083](#) [LMR22007YMINI-EVM](#) [LP38501ATJ-EV](#)