



Low-Noise, Regulated, Negative Charge-Pump Power Supplies for GaAsFET Bias

General Description

The MAX850–MAX853 low-noise, inverting, charge-pump power supplies are ideal for biasing GaAsFETs in cellular telephone transmitter amplifiers.

The MAX850–MAX852 offer both preset (-4.1V) and adjustable (-0.5V to -9.0V) output voltages. The MAX853 uses an external positive control voltage to set the negative output voltage. Input voltage range for all four devices is 4.5V to 10V. Output current is 5mA.

An internal linear regulator reduces the output voltage ripple to 2mVp-p. With a well-filtered control voltage (V_{CTRL}), the MAX853 achieves typical output ripple of less than 1mVp-p. Supply current is 3mA max, and shutdown current is less than 1 μ A max over temperature (5 μ A max for MAX851).

Applications

Cellular Phones
Negative Regulated Power Supplies
Personal Communicators, PDAs
Wireless Data Loggers
Continuously Adjustable GaAsFET Bias
LCD-Bias Contrast Control

Typical Operating Circuit

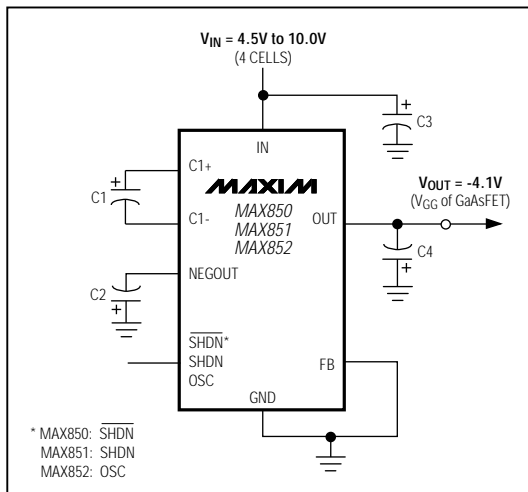

Features

- ◆ Fixed -4.1V or Adjustable -0.5V to -9V Output at 5mA
- ◆ 4.5V to 10V Input Voltage Range
- ◆ 2mVp-p Output Voltage Ripple (MAX850–MAX852)
1mVp-p Output Voltage Ripple (MAX853)
- ◆ 100kHz Charge-Pump Switching Frequency (MAX850/MAX851/MAX853)
- ◆ External Synchronizing Clock Input (MAX852)
- ◆ Logic-Level Shutdown Mode: 1 μ A Max Over Temperature (MAX850/MAX852/MAX853)
- ◆ Low Cost, 8-Pin SO Package

Ordering Information

PART	TEMP. RANGE	PIN-PACKAGE
MAX850C/D	0°C to +70°C	Dice*
MAX850ISA	-25°C to +85°C	8 SO
MAX850ESA	-40°C to +85°C	8 SO
MAX851C/D	0°C to +70°C	Dice*
MAX851ISA	-25°C to +85°C	8 SO
MAX851ESA	-40°C to +85°C	8 SO
MAX852C/D	0°C to +70°C	Dice*
MAX852ISA	-25°C to +85°C	8 SO
MAX852ESA	-40°C to +85°C	8 SO
MAX853C/D	0°C to +70°C	Dice*
MAX853ISA	-25°C to +85°C	8 SO
MAX853ESA	-40°C to +85°C	8 SO

* Dice are specified at $T_A = +25^\circ\text{C}$ only.

Pin Configuration

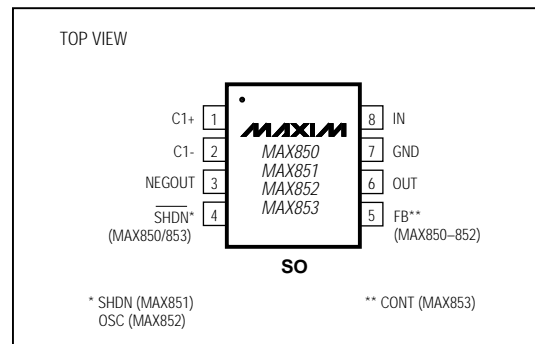

MAX850-MAX853

Low-Noise, Regulated, Negative Charge-Pump Power Supplies for GaAsFET Bias

ABSOLUTE MAXIMUM RATINGS

Supply Voltage, V_{IN} to GND	-0.3V to 10.5V	Operating Temperature Ranges	
V_{NEGOUT} to GND	-10.5V to 0.3V	MAX85_ISA	-25°C to +85°C
V_{IN} to V_{NEGOUT}	-0.3V to 21V	MAX85_ESA	-40°C to +85°C
V_{OUT} to GND (Note 1)	V_{NEGOUT} to 0.3V	Storage Temperature Range	-65°C to +160°C
\overline{SHDN} or OSC (pin 4) Voltage to GND	-0.3V to ($V_{IN} + 0.3V$)	Lead Temperature (soldering, 10sec)	+300°C
Continuous Power Dissipation ($T_A = +70^\circ\text{C}$)			
SO (derate 5.88mW/°C above +70°C)	471mW		

Note 1: The output may be shorted to NEGOUT or GND if the package power dissipation is not exceeded. Typical short-circuit current to GND is 50mA.

Stresses beyond those listed under "Absolute Maximum Ratings" may cause permanent damage to the device. These are stress ratings only, and functional operation of the device at these or any other conditions beyond those indicated in the operational sections of the specifications is not implied. Exposure to absolute maximum rating conditions for extended periods may affect device reliability.

ELECTRICAL CHARACTERISTICS

($+5V \leq V_{IN} \leq +10V$, GND = 0V, $V_{OUT} = -4.1V$, $R_L = \infty$, $T_A = T_{MIN}$ to T_{MAX} , unless otherwise noted. A 100kHz, 50% duty cycle square wave between GND and V_{IN} is applied to OSC on the MAX852.)

PARAMETER	SYMBOL	CONDITIONS	MIN	TYP	MAX	UNITS
Supply Voltage Range (Note 2)	V_{IN}		5		10	V
Output Voltage	V_{OUT}	MAX850-MAX852, $V_{FB} = 0V$, $R_L = \infty$ or 820 Ω , Figure 2a	-4.3	-4.1	-3.9	V
		MAX853, $V_{CTRL} = 4.1V$, $R_L = \infty$ or 820 Ω , Figure 2c	-4.2		-4.0	
Output Voltage Range			-0.5		$-(V_{IN} - 1)$	V
Set Voltage	V_{FBset}	MAX850-MAX852, no load, Figure 2b	-1.32	-1.28	-1.24	V
Supply Current	I_Q			2.0	3.0	mA
Shutdown Supply Current	I_{SHUT}	MAX850/MAX853, $V_{IN} = 10V$, $\overline{SHDN} = 0V$		0.002	1	μA
		MAX851, $\overline{SHDN} = 2V$		2	5	
		MAX852, OSC low			1	
V_{OUT} Load Regulation		MAX850-MAX852, $V_{FB} = 0V$, $R_L = \infty$ or 820 Ω , Figure 2a		4	8	mV/mA
		MAX853, $V_{CTRL} = 4.1V$, $R_L = \infty$ or 820 Ω , Figure 2c		3	8	
V_{OUT} Ripple		MAX850-MAX852		2		mVp-p
		MAX853		1		
Oscillator Frequency (Note 3)	f_{OSC}	MAX850/MAX851/MAX853, $T_A = +25^\circ\text{C}$	80	100	120	kHz
Input High Voltage	V_{IH}	Pin 4	2.0			V
Input Low Voltage	V_{IL}	Pin 4			0.5	V
Input Current	I_{IN}	Pin 4			± 1	μA
Input Capacitance	C_{IN}	Pin 4		10		pF

Note 2: The supply voltage can drop to 4.5V, but the output may no longer sink 5mA at -4.1V.

Note 3: The MAX852 will operate with a 50kHz to 250kHz square wave of 40% to 60% duty cycle. For best performance, use an 80kHz to 120kHz square wave with 50% duty cycle.

Low-Noise, Regulated, Negative Charge-Pump Power Supplies for GaAsFET Bias

Typical Operating Characteristics

(Circuit of Figure 2a, $V_{IN} = 6V$, $T_A = +25^\circ C$, unless otherwise noted.)

MAX850-MAX853

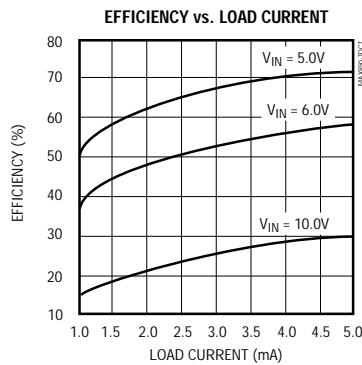
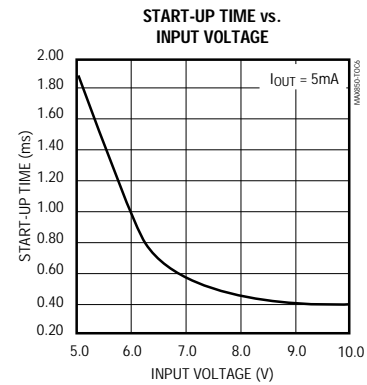
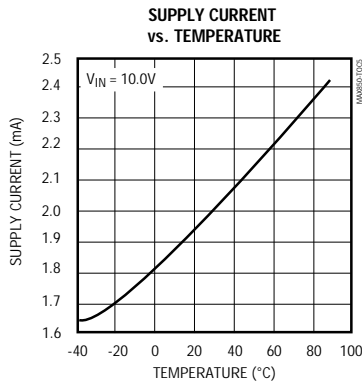
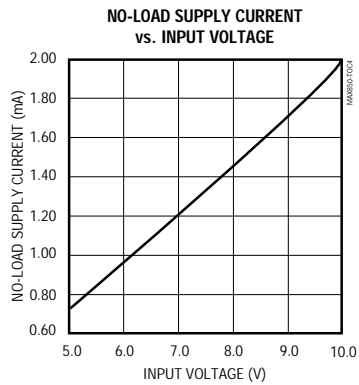
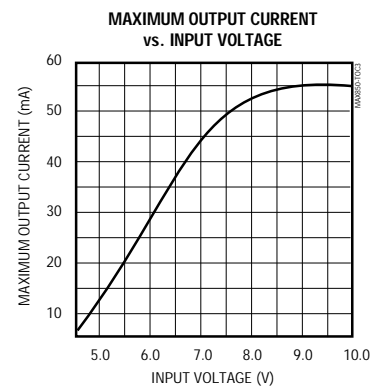
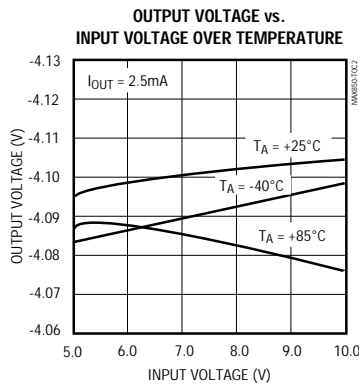
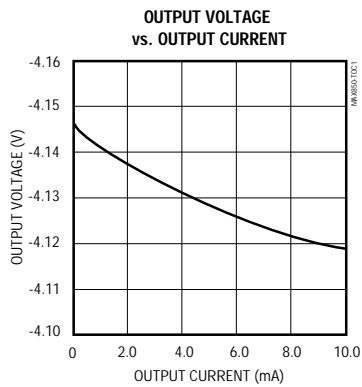

Low-Noise, Regulated, Negative Charge-Pump Power Supplies for GaAsFET Bias

Typical Operating Characteristics (continued)

(Circuit of Figure 2a, $V_{IN} = 6V$, $T_A = +25^\circ C$, unless otherwise noted.)

**MAX850-MAX852
OUTPUT NOISE AND RIPPLE**

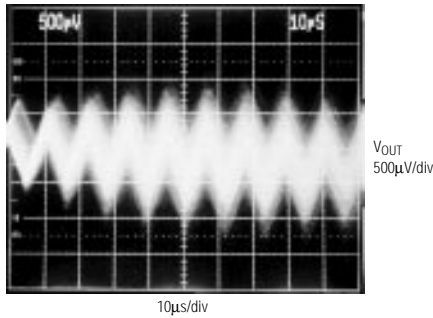

$V_{IN} = 6.0V$, $V_{OUT} = -4.1V$, $I_{OUT} = 5mA$, AC COUPLED

**MAX853
OUTPUT NOISE AND RIPPLE**

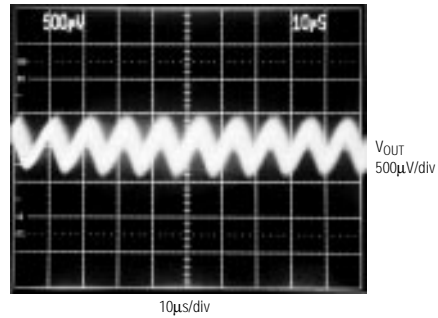

$V_{IN} = 6.0V$, $V_{OUT} = -4.1V$, $I_{OUT} = 5mA$, AC COUPLED

**MAX850-MAX852
NOISE SPECTRUM**

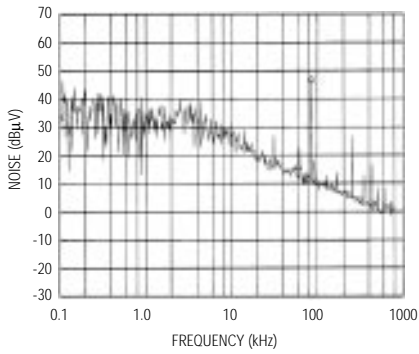

**MAX853
NOISE SPECTRUM**

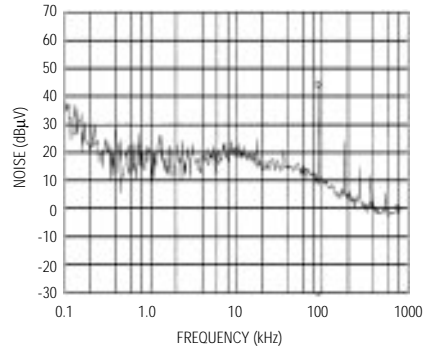

NOTE: $dB\mu V = 20 \log \frac{V_{OUT}}{1\mu V}$

Low-Noise, Regulated, Negative Charge-Pump Power Supplies for GaAsFET Bias

Typical Operating Characteristics (continued)

(Circuit of Figure 2a, $V_{IN} = 6V$, $T_A = +25^\circ C$, unless otherwise noted.)

MAX850-MAX853

MAX850/MAX851/MAX853
START-UP FROM SHUTDOWN

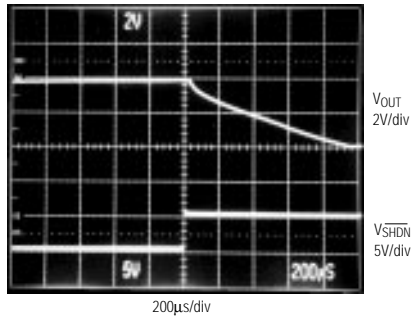

CIRCUIT OF FIGURE 2a, $V_{IN} = 6.0V$, $V_{OUT} = -4.1V$, $I_{OUT} = 5mA$

MAX852
START-UP FROM SHUTDOWN

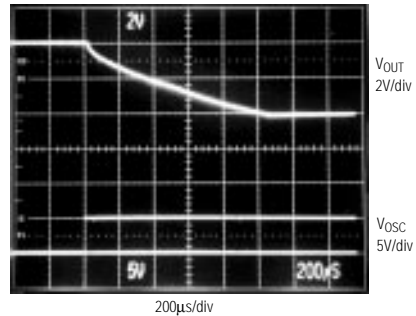

CIRCUIT OF FIGURE 2a, $V_{IN} = 6.0V$, $V_{OUT} = -4.1V$, $I_{OUT} = 5mA$
SHUTDOWN OCCURS WHEN 100kHz EXTERNAL CLOCK IS GATED OFF

LINE-TRANSIENT RESPONSE

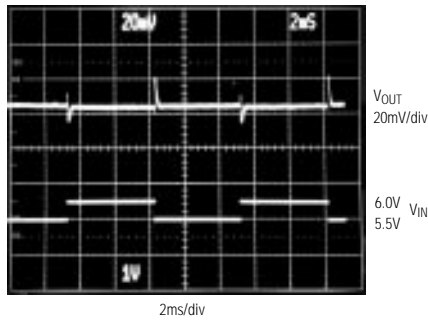

$V_{OUT} = -4.08V$, $I_{OUT} = 5mA$, AC COUPLED

LOAD-TRANSIENT RESPONSE

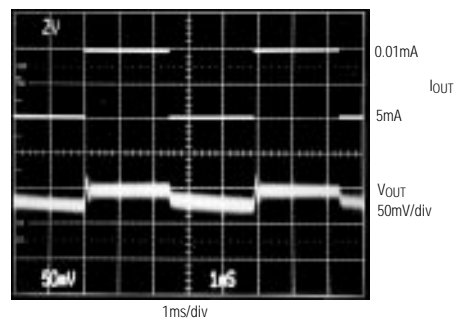

$V_{OUT} = -4.0V$, AC COUPLED

Low-Noise, Regulated, Negative Charge-Pump Power Supplies for GaAsFET Bias

Pin Description

PIN				NAME	FUNCTION
MAX850	MAX851	MAX852	MAX853		
1	1	1	1	C1+	Positive terminal for C1
2	2	2	2	C1-	Negative terminal for C1
3	3	3	3	NEGOUT	Negative Output Voltage (unregulated), $V_{NEGOUT} = V_{IN} + 0.2V$
4	-	-	4	\overline{SHDN}	Active-low TTL logic level Shutdown Input
-	4	-	-	SHDN	Active-high TTL logic level Shutdown Input
-	-	4	-	OSC	External Clock Input
5	5	5	-	FB	Dual-Mode Feedback Input. When FB is grounded, the output is preset to -4.1V. To select other output voltages, connect FB to an external resistor divider. See Figure 2b.
-	-	-	5	CONT	Control Voltage Input. To set V_{OUT} , connect a resistor divider between OUT and a positive control voltage between 0V and 10V. See Figure 2c.
6	6	6	6	OUT	Output Voltage
7	7	7	7	GND	Ground
8	8	8	8	IN	Positive Power-Supply Input (4.5V to 10V)

Detailed Description

The MAX850-MAX853 are low-noise, inverting, regulated charge-pump power supplies designed for biasing GaAsFET devices, such as power-amplifier modules in cellular handsets.

The applied input voltage (V_{IN}) is first inverted to a negative voltage at NEGOUT by a capacitive charge pump. This voltage is then regulated by an internal lin-

ear regulator, and appears at OUT (Figure 1). The minimum (most negative) output voltage (V_{OUT}) achievable is the inverted positive voltage, plus the 1.0V required by the post-regulator. The ripple noise induced by the charge-pump inverter is reduced by the linear regulator to 2mVp-p at V_{OUT} for the MAX850-MAX852. In addition, the excellent AC rejection of the linear regulator attenuates noise on the incoming supply. Up to 5mA is available at OUT.

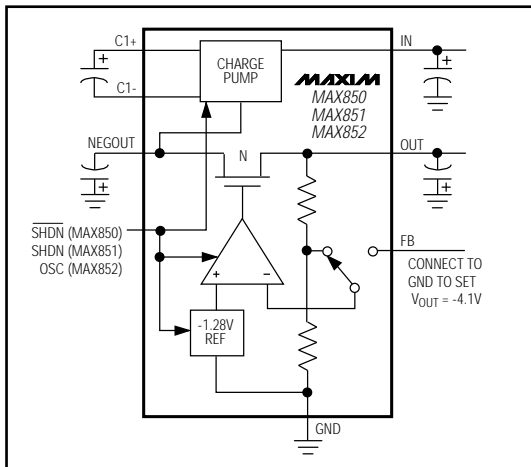

Figure 1a. MAX850-MAX852 Block Diagram

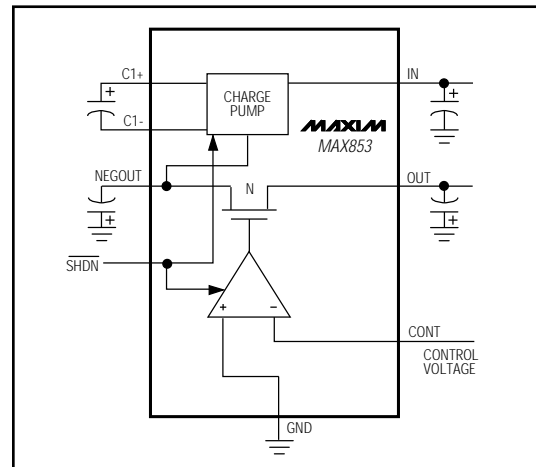

Figure 1b. MAX853 Block Diagram

Low-Noise, Regulated, Negative Charge-Pump Power Supplies for GaAsFET Bias

MAX850-MAX853

Applications Information

Setting the Output Voltage

For the MAX850-MAX852, select either a fixed or an adjustable output voltage. Connect FB directly to GND to select the fixed -4.1V output (Figure 2a). To select an alternate output voltage, connect FB to the midpoint of a resistor voltage divider from OUT to GND (Figure 2b). V_{IN} must be 1.0V above the absolute value of V_{OUT} to allow proper regulation. The output voltage is calculated from the formula below. Choose R2 to be between 100k Ω to 400k Ω .

$$V_{OUT} = (-1.28) \left(1 + \frac{R2}{R1} \right)$$

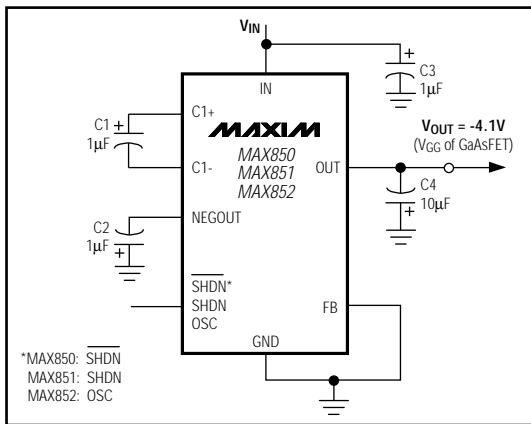

Figure 2a. MAX850/MAX851/MAX852 Standard Application Circuit

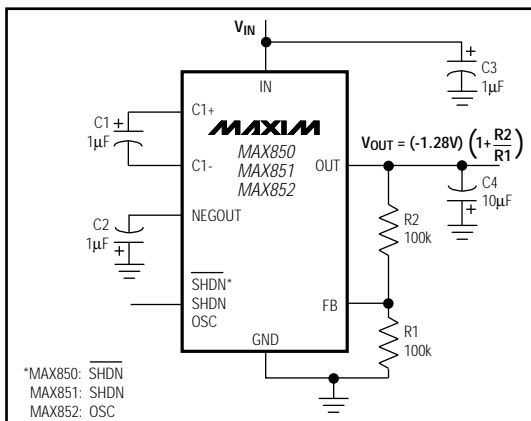

Figure 2b. MAX850/MAX851/MAX852 Adjustable Configuration

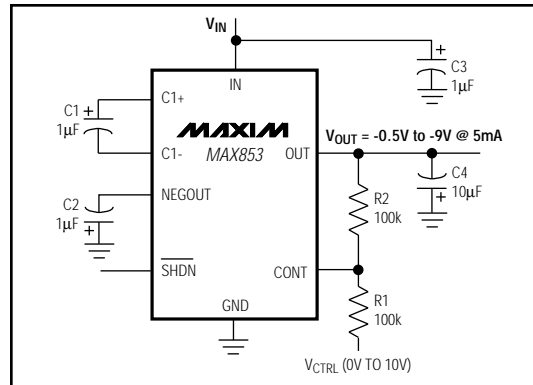

Figure 2c. MAX853 Standard Application Circuit

For the MAX853, set the output voltage, V_{OUT} , by connecting a resistor voltage divider between OUT and a positive control voltage, V_{CTRL} (Figure 2c.)

$$V_{OUT} = -V_{CTRL} \left(\frac{R2}{R1} \right)$$

Shutdown

The MAX850-MAX853 feature a shutdown mode that reduces the supply current to 1 μ A max over temperature (5 μ A max for the MAX851). The MAX850 and MAX853 have an active-low TTL logic level SHDN input, whereas the MAX851 has an active-high SHDN input. To shut down the MAX852, set the OSC input to a logic-low level. The device is powered up by the resumption of the clock signal.

Capacitors

Use capacitors with low effective series resistance (ESR) to maintain a low dropout voltage ($V_{IN} - |V_{OUT}|$). The overall dropout voltage is a function of the charge pump's output resistance and the voltage drop across the linear regulator (N-channel pass transistor). At the 100kHz switching frequency, the charge-pump output resistance is a function of C1 and C2's ESR. Therefore, minimizing the ESR of the charge-pump capacitors minimizes the dropout voltage.

1 μ F, 0.8 Ω ESR capacitors are recommended for C1, C2, and C3. C4 should be 10 μ F, 0.2 Ω ESR. All capacitors should be either surface-mount chip tantalum or chip ceramic types. External capacitor values may be adjusted to optimize size and cost.

Switching-Frequency Control

Use the MAX852 to minimize system interference caused by conflicting clock frequencies. An external oscillator can set the charge-pump frequency and reduce clock frequency

Low-Noise, Regulated, Negative Charge-Pump Power Supplies for GaAsFET Bias

sensitivity and interference. The clock must be a square wave between 40% and 60% duty cycle. The maximum clock frequency is 250kHz, and the minimum frequency is 50kHz.

Layout and Grounding

Good layout is important, primarily for good noise performance.

- 1) Mount all components as close together as possible.
- 2) Keep traces short to minimize parasitic inductance and capacitance. This includes connections to FB.
- 3) Use a ground plane.

Noise and Ripple Measurement

Accurately measuring the output noise and ripple is a challenge. Brief differences in ground potential between the MAX850-MAX853 circuit and the oscilloscope (which result from the charge pump's switching action) cause ground currents in the probe's wires, inducing sharp voltage spikes. For best results, measure directly across the output capacitor (C4). Do not use the ground lead of the oscilloscope probe; instead, remove the probe's tip cover and touch the ground ring on the probe directly to C4's ground terminal. You can also use a Tektronix chassis mount test jack (part no. 131-0258) to connect your scope probe directly. This direct connection gives the most accurate noise and ripple measurement.

Chip Topography

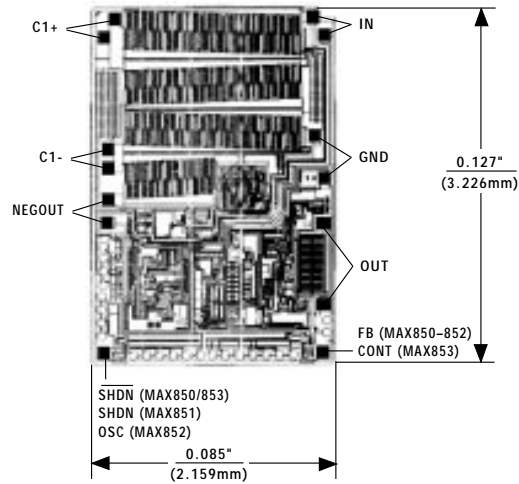

TRANSISTOR COUNT: 164
SUBSTRATE CONNECTED TO IN

Package Information

DIM	INCHES		MILLIMETERS	
	MIN	MAX	MIN	MAX
A	0.053	0.069	1.35	1.75
A1	0.004	0.010	0.10	0.25
B	0.014	0.019	0.35	0.49
C	0.007	0.010	0.19	0.25
D	0.189	0.197	4.80	5.00
E	0.150	0.157	3.80	4.00
e	0.050 BSC		1.27 BSC	
H	0.228	0.244	5.80	6.20
h	0.010	0.020	0.25	0.50
L	0.016	0.050	0.40	1.27
α	0°	8°	0°	8°

21-325A

**8-PIN PLASTIC
SMALL-OUTLINE
PACKAGE**

X-ON Electronics

Largest Supplier of Electrical and Electronic Components

Click to view similar products for [Switching Voltage Regulators](#) category:

Click to view products by [Maxim](#) manufacturer:

Other Similar products are found below :

[FAN53610AUC33X](#) [FAN53611AUC123X](#) [FAN48610BUC33X](#) [FAN48610BUC45X](#) [FAN48617UC50X](#) [R3](#) [430464BB](#) [KE177614](#)
[MAX809TTR](#) [NCV891234MW50R2G](#) [NCP81103MNTXG](#) [NCP81203PMNTXG](#) [NCP81208MNTXG](#) [NCP81109GMNTXG](#)
[SCY1751FCCT1G](#) [NCP81109JMNTXG](#) [AP3409ADNTR-G1](#) [LTM8064IY](#) [LT8315EFE#TRPBF](#) [NCV1077CSTBT3G](#) [XCL207A123CR-G](#)
[MPM54304GMN-0002](#) [MPM54304GMN-0003](#) [XDPE132G5CG000XUMA1](#) [DA9121-B0V76](#) [LTC3644IY#PBF](#) [MP8757GL-P](#)
[MIC23356YFT-TR](#) [LD8116CGL](#) [HG2269M/TR](#) [OB2269](#) [XD3526](#) [U6215A](#) [U6215B](#) [U6620S](#) [LTC3803ES6#TR](#) [LTC3803ES6#TRM](#)
[LTC3412IFE](#) [LT1425IS](#) [MAX25203BATJA/VY+](#) [MAX77874CEWM+](#) [XC9236D08CER-G](#) [ISL95338IRTZ](#) [MP3416GJ-P](#) [BD9S201NUX-](#)
[CE2](#) [MP5461GC-Z](#) [MPQ4415AGQB-Z](#) [MPQ4590GS-Z](#) [MCP1603-330IMC](#) [MCP1642B-18IMC](#)