



MAX8727 Evaluation Kit

General Description

The MAX8727 evaluation kit (EV kit) is a fully assembled and tested surface-mount circuit board that contains a pulse-width-modulated (PWM) step-up DC-DC converter. The EV kit is configured to operate with a 1.2MHz switching frequency. It operates from a 2.6V to 5.5V DC supply voltage, is configured for a 15V output, and can provide 600mA with a 4.5V input.

The MAX8727 EV kit features low quiescent current and high conversion efficiency (90%). The high switching frequency allows for the use of small surface-mount components.

Features

- ◆ 90% Efficiency
- ◆ 2.6V to 5.5V Input Range
- ◆ 15V Output Voltage (Adjustable from V_{IN} to 24V)
- ◆ 600mA Output Current (4.5V Input)
- ◆ 1.2MHz Switching Frequency (Selectable: 640kHz or 1.2MHz)
- ◆ Programmable Soft-Start
- ◆ 0.1 μ A IC Shutdown Current (typ)
- ◆ Fully Assembled and Tested

Ordering Information

PART	TEMP RANGE	IC PACKAGE
MAX8727EVKIT	0°C to +70°C	10 TDFN (3mm x 3mm)

Component List

DESIGNATION	QTY	DESCRIPTION
C1	0	Not installed, ceramic capacitor (0805)
C2	1	10 μ F \pm 10%, 6.3V X5R ceramic capacitor (0805) Murata GRM21BR60J106K Taiyo Yuden JMK212BJ106K
C3	1	1 μ F \pm 10%, 6.3V X5R ceramic capacitor (0603) Murata GRM188R60J105K
C4	1	0.033 μ F \pm 10%, 25V X7R ceramic capacitor (0603) Murata GRM188R71E333K
C5	1	330pF \pm 10%, 50V X7R ceramic capacitor (0603) Murata GRM188R71H331K
C6	1	39pF \pm 5%, 50V C0G ceramic capacitor (0603) Murata GRM1885C1H390J Taiyo Yuden UMK107CG390JZ
C7, C8, C9	3	4.7 μ F \pm 20%, 25V X7R ceramic capacitors (1206) Murata GRM31CR71E475M Taiyo Yuden TMK316BJ475KL

DESIGNATION	QTY	DESCRIPTION
C10	1	100 μ F \pm 20%, 6.3V aluminum electrolytic capacitor (SMT: 6.3mm x 6.0mm) Sanyo 6CV100AX
D1	1	3A, 30V Schottky diode (M-flat) Toshiba CMS02
JU1	1	2-pin header
JU2	0	Not installed, 3-pin header
L1	1	3.6 μ H \pm 30%, 3.5A power inductor Sumida CDR7D28MNNP-3R6
R1	1	309k Ω \pm 1% resistor (0603)
R2	1	28.0k Ω \pm 1% resistor (0603)
R3, R4	2	100k Ω \pm 5% resistors (0603)
R5	0	Not installed; short by PC trace (0603)
U1	1	MAX8727ETB+ (10-pin TDFN 3mm x 3mm) (top mark AMV)
—	1	Shunt
—	1	MAX8727 EV kit PC board

MAX8727 Evaluation Kit

Recommended Equipment

- 2.6V to 5.5V, 5A DC power supply (VIN)
- Voltmeter

Quick Start

The MAX8727 EV kit is fully assembled and tested. Follow these steps to verify board operation. **Do not turn on the power supply until all connections are completed:**

- 1) Verify that there is no shunt placed across jumper JU1 to enable the MAX8727.
- 2) Connect the positive terminal of the DC power supply to the VIN pad. Connect the negative terminal of the DC power supply to the GND pad above the VIN pad.
- 3) Connect the voltmeter across the VOUT and GND pads.
- 4) Turn on the 2.6V to 5.5V DC power supply and verify that the output is 15V.

Detailed Description

The MAX8727 EV kit contains a high-efficiency, PWM step-up DC-DC converter. The MAX8727 features a programmable soft-start, loop compensation pin, and an internal MOSFET switch. The EV kit operates from a 2.6V to 5.5V DC power supply, provides a regulated 15V output, and is capable of providing a 600mA load current with a 4.5V input. The EV kit is configured for a 5V input, a 15V output, and a 1.2MHz switching frequency. **Operation at a different input voltage, output voltage, or switching frequency may require a different inductor, output capacitor, and compensation components.** Refer to the MAX8727 data sheet for detailed information on loop compensation and component selection.

Jumper Selection

Shutdown Mode (*SHDN*)

The EV kit features a shutdown mode that reduces the MAX8727 quiescent current. JU1 selects the shutdown mode. See Table 1 for jumper JU1 functions.

Switching-Frequency Selection (*FREQ*)

The MAX8727 EV kit provides the option to configure the switching frequency of the step-up DC-DC converter. Table 2 lists jumper JU2 settings for configuring the switching frequency. The EV kit is configured and shipped to operate at 1.2MHz. For operation at 640kHz, cut the trace between pins 1 and 2 of jumper JU2 and short pins 2 and 3. Refer to the MAX8727 data sheet for selecting the proper components.

Table 1. Jumper JU1 Functions

SHUNT LOCATION	<i>SHDN</i> PIN	MAX8727 OUTPUT
Installed	Connected to GND	Shutdown mode, $V_{OUT} = V_{IN} - V_{DIODE}$
Not installed (default)	Connected to VIN through R4	MAX8727 enabled, $V_{OUT} = 15V$

Table 2. Jumper JU2 Functions

SHUNT LOCATION	FREQ PIN	SWITCHING FREQUENCY
1-2 (default)	Connected to VIN with a PC trace	1.2MHz
2-3	Connected to GND (cut the trace between pins 1-2 before shorting pins 2-3)	640kHz

Evaluating Other Output Voltages

The EV kit is configured to provide a 15V output voltage. However, the output voltage can be adjusted from V_{IN} to 24V by selecting appropriate R1 and R2 values. Select R2 in the 10k Ω to 50k Ω range. R1 is then given by:

$$R1 = R2 \times \left[\left(\frac{V_{OUT}}{V_{FB}} \right) - 1 \right]$$

where $V_{FB} = 1.24V$. For significantly different operation points, the EV kit may require a different inductor and component changes. Refer to the MAX8727 data sheet for proper component selection.

MAX8727 Evaluation Kit

Component Suppliers

SUPPLIER	PHONE	FAX	WEBSITE
Murata	770-436-1300	770-436-3030	www.murata.com
Sanyo	619-661-4134	619-661-1055	www.sanyovideo.com
Sumida	847-545-6700	847-545-6720	www.sumida.com
Taiyo Yuden	408-573-4150	408-573-4159	www.t-yuden.com
Toshiba	949-455-2000	949-859-3963	www.toshiba.com/taec

Note: Indicate that you are using the MAX8727 when contacting these suppliers.

Evaluates: MAX8727

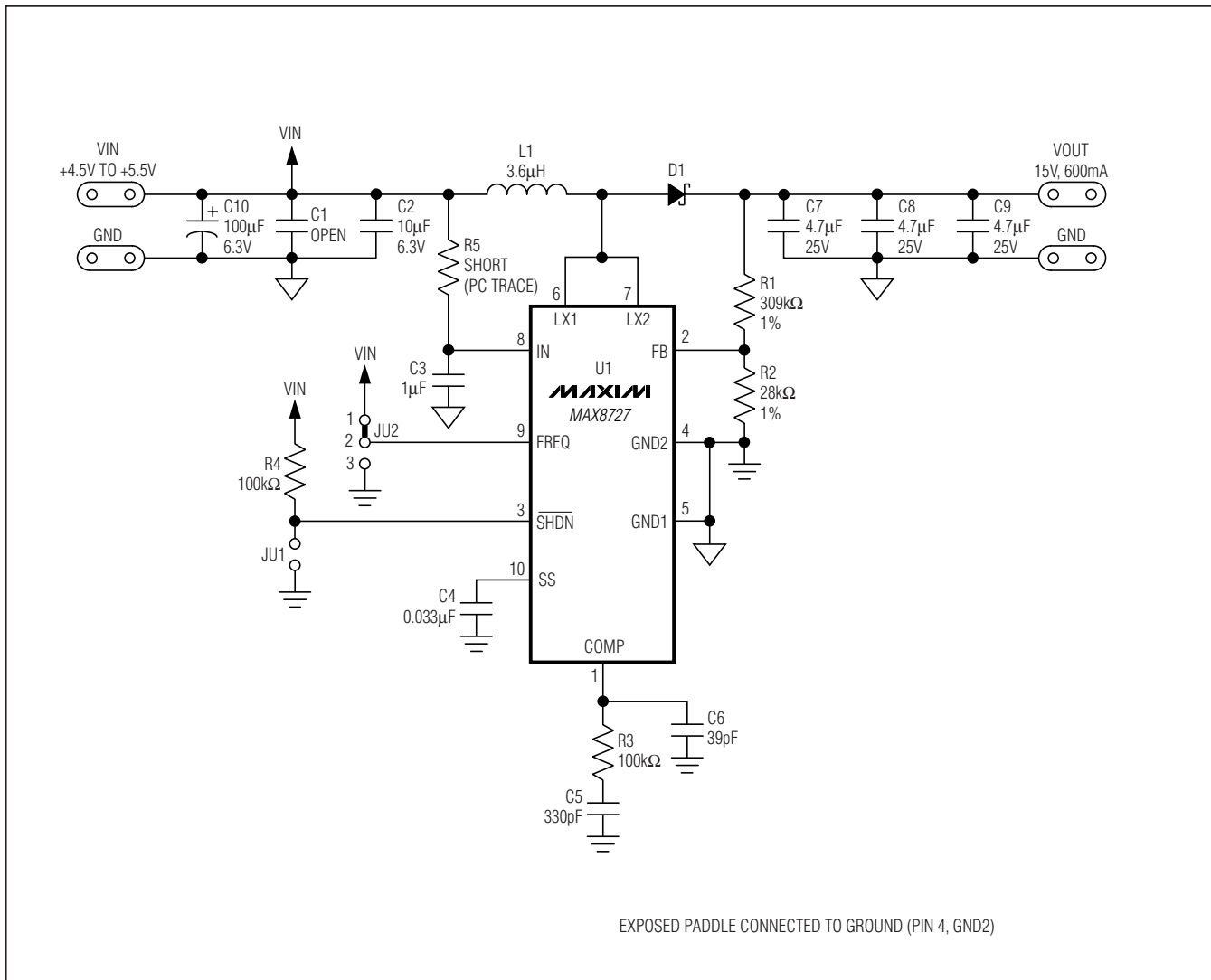

Figure 1. MAX8727 EV Kit Schematic

MAX8727 Evaluation Kit

Evaluates: MAX8727

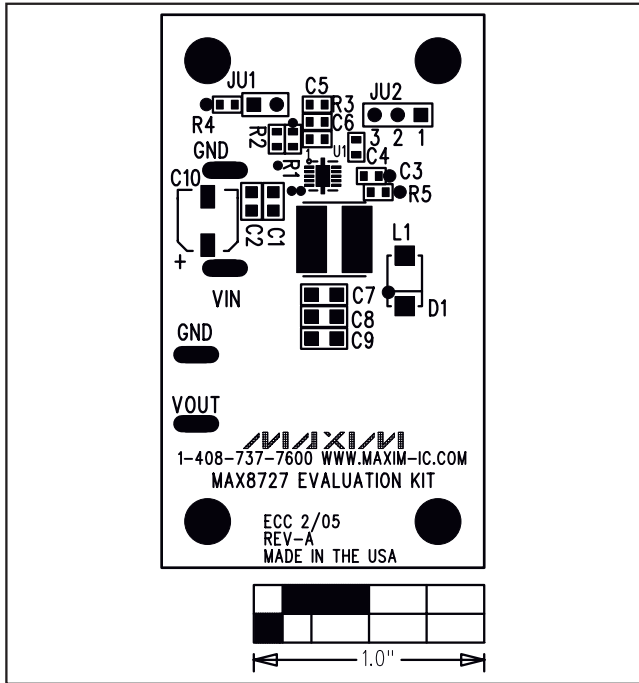

Figure 2. MAX8727 EV Kit Component Placement Guide—Component Side

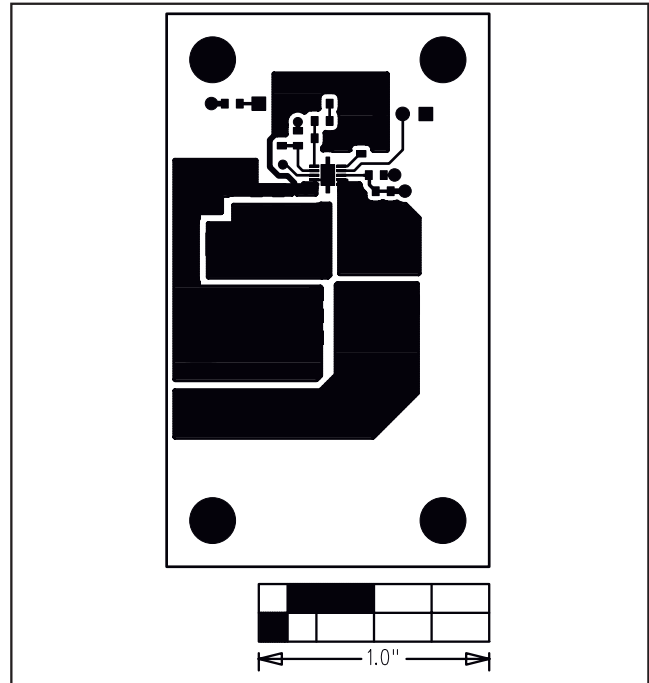

Figure 3. MAX8727 EV Kit PC Board Layout—Component Side

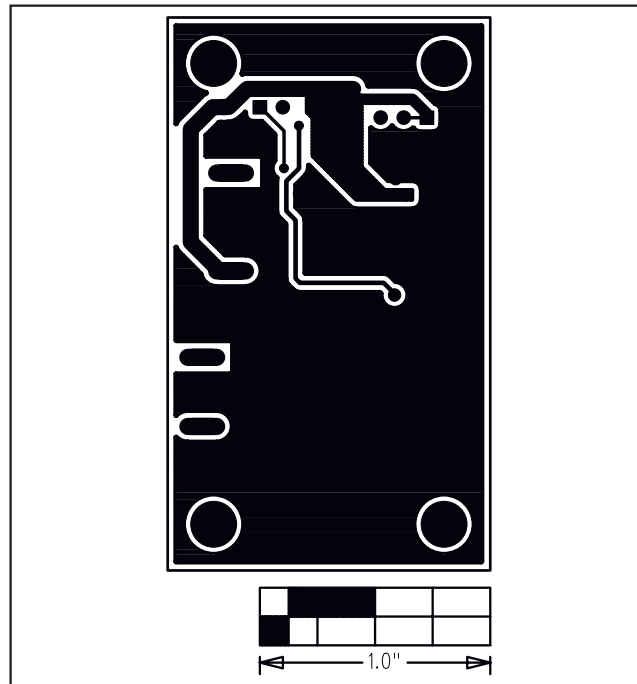

Figure 4. MAX8727 EV Kit PC Board Layout—Solder Side

Maxim cannot assume responsibility for use of any circuitry other than circuitry entirely embodied in a Maxim product. No circuit patent licenses are implied. Maxim reserves the right to change the circuitry and specifications without notice at any time.

4 _____ **Maxim Integrated Products, 120 San Gabriel Drive, Sunnyvale, CA 94086 408-737-7600**

X-ON Electronics

Largest Supplier of Electrical and Electronic Components

Click to view similar products for [Power Management IC Development Tools](#) category:

Click to view products by [Maxim](#) manufacturer:

Other Similar products are found below :

[EVAL-ADM1168LQEBZ](#) [EVB-EP5348UI](#) [MIC23451-AAAYFL EV](#) [MIC5281YMME EV](#) [DA9063-EVAL](#) [ADP122-3.3-EVALZ](#) [ADP130-0.8-EVALZ](#) [ADP130-1.2-EVALZ](#) [ADP130-1.5-EVALZ](#) [ADP130-1.8-EVALZ](#) [ADP1712-3.3-EVALZ](#) [ADP1714-3.3-EVALZ](#) [ADP1715-3.3-EVALZ](#) [ADP1716-2.5-EVALZ](#) [ADP1740-1.5-EVALZ](#) [ADP1752-1.5-EVALZ](#) [ADP1828LC-EVALZ](#) [ADP1870-0.3-EVALZ](#) [ADP1871-0.6-EVALZ](#) [ADP1873-0.6-EVALZ](#) [ADP1874-0.3-EVALZ](#) [ADP1882-1.0-EVALZ](#) [ADP199CB-EVALZ](#) [ADP2102-1.25-EVALZ](#) [ADP2102-1.875EVALZ](#) [ADP2102-1.8-EVALZ](#) [ADP2102-2-EVALZ](#) [ADP2102-3-EVALZ](#) [ADP2102-4-EVALZ](#) [ADP2106-1.8-EVALZ](#) [ADP2147CB-110EVALZ](#) [AS3606-DB](#) [BQ24010EVM](#) [BQ24075TEVM](#) [BQ24155EVM](#) [BQ24157EVM-697](#) [BQ24160EVM-742](#) [BQ24296MEVM-655](#) [BQ25010EVM](#) [BQ3055EVM](#) [NCV891330PD50GEVB](#) [ISLUSBI2CKIT1Z](#) [LM2744EVAL](#) [LM2854EVAL](#) [LM3658SD-AEV/NOPB](#) [LM3658SDEV/NOPB](#) [LM3691TL-1.8EV/NOPB](#) [LM4510SDEV/NOPB](#) [LM5033SD-EVAL](#) [LP38512TS-1.8EV](#)