



MAX8792 Evaluation Kit

Evaluates: MAX8792

General Description

The MAX8792 evaluation kit (EV kit) demonstrates the standard 10A application circuit of the MAX8792. This DC-DC converter steps down high-voltage batteries to generate low-voltage core or chipset/RAM bias supplies in notebook computers.

The MAX8792 EV kit provides a dynamically adjustable 1.5V/1.05V output voltage from a 7V to 24V battery-input range. It delivers up to 10A output current while achieving greater than 90% efficiency. Programmed by a single resistor, the EV kit operates at 300kHz switching frequency and has superior line- and load-transient response.

The EV kit is a fully assembled and tested PCB. It also allows the evaluation of other dynamically adjustable output voltages by varying the external reference input, which can be realized by changing resistors R1, R2, and R3.

Features

- ◆ 7V to 24V Input Range
- ◆ Dynamically Selectable 1.5V/1.05V Output Voltage
- ◆ Dynamically Adjustable Output Voltage (0 to V_{IN} Range)
- ◆ 10A Output Current
- ◆ 93% Efficiency ($V_{IN} = 7V$, $V_{OUT} = 1.5V$ at 3A)
- ◆ 300kHz Switching Frequency
- ◆ Power-Good Output Indicator (PGOOD)
- ◆ Low-Profile, Surface-Mount Components
- ◆ Fully Assembled and Tested

Ordering Information

PART	TYPE
MAX8792EVKIT+	EV Kit

+Denotes lead(Pb)-free and RoHS compliant.

Component List

DESIGNATION	QTY	DESCRIPTION
C1, C2	2	1 μ F \pm 10%, 6.3V X5R ceramic capacitors (0402) TDK C1005X5R0J105K KEMET C0402C105K9PAC
C3	1	1000pF \pm 10%, 50V ceramic capacitor (0402) KEMET C0402C102K5RAC TDK C1005X7R1H102K
C4, C5	2	10 μ F \pm 20%, 25V X5R ceramic capacitors (1210) TDK C3225X7R1E106M Taiyo Yuden TMK325BJ106MM
C6	0	Not installed, capacitor
C7	1	0.1 μ F \pm 10%, 25V X7R ceramic capacitor (0603) TDK C1608X7R1E104K Murata GRM188R71E104K
C8, C9, C13	0	Not installed, capacitors (0603)

DESIGNATION	QTY	DESCRIPTION
C10, C11	2	330 μ F, 2.0V, 6m Ω polymer capacitors (D case) Panasonic EEFSX0D331XR (6m Ω ESR, 1.9mm height) NEC/TOKIN PSGD0E337M7 (7m Ω ESR, 2.8mm height)
C12	1	10 μ F \pm 20%, 6.3V X5R ceramic capacitor (0805) TDK C2012X5R0J106M KEMET C0805C106K9PAC
D1	1	2A, 30V Schottky diode (SMA) Nihon EC21QS03L Central Semiconductor CSMH2-40M
D2	1	Green surface-mount LED (0805) Lite-ON LTST-C170GKT Digi-Key 160-1179-1-ND
EN, GATE, PGOOD, REFIN, SKIP	5	Test points Keystone 5000
JU1	1	3-pin header
JU2	1	2-pin header
JU3	1	4-pin header

MAX8792 Evaluation Kit

Component List (continued)

DESIGNATION	QTY	DESCRIPTION
L1	1	1.0 μ H, 3.25m Ω , 16A power inductor Würth 744 355 2100
N1	1	30V n-channel MOSFET (PowerPAK [®] 8-pin SO) Fairchild FDMS8690 Vishay/Siliconix SI7634DP
N2	1	30V n-channel MOSFET (PowerPAK 8-pin SO) Fairchild FDS8670 Vishay/Siliconix SI7336ADP
N3	1	n-channel logic-level MOSFET (SOT23) Fairchild 2N7002 (Top Mark: 702) Diodes Inc. ZVN3306F (Top Mark: MC)
N4	0	Not installed
R1, R11	2	49.9k Ω \pm 1% resistors (0603)
R2	1	54.9k Ω \pm 1% resistor (0603)
R3	1	97.6k Ω \pm 1% resistor (0603)
R4	1	1k Ω \pm 5% resistor (0603)
R5	0	Not installed, resistor (0402)
R6	1	200k Ω \pm 1% resistor (0603)
R7, R13	0	Not installed, resistors (short PC trace) (0603)
R8, R10	0	Not installed, resistors (0603)
R9	1	0 Ω \pm 5% resistor (0603)
R12	1	100k Ω \pm 1% resistor (0603)
R14	1	100k Ω \pm 5% resistor (0603)
U1	1	PWM controller (14 TDFN-EP*) Maxim MAX8792ETD+
—	3	Shunts
—	1	PCB: MAX8792 EVALUATION KIT+

*EP = Exposed pad.

PowerPAK is a registered trademark of Vishay Siliconix.

Component Suppliers

SUPPLIER	PHONE	WEBSITE
Central Semiconductor Corp.	631-435-1110	www.centalsemi.com
Diodes Incorporated	805-446-4800	www.diodes.com
Fairchild Semiconductor	888-522-5372	www.fairchildsemi.com
KEMET Corp.	864-963-6300	www.kemet.com
Murata Electronics North America, Inc.	770-436-1300	www.murata-northamerica.com
NEC TOKIN America, Inc.	408-324-1790	www.nec-tokin.com
Nihon Inter Electronics Corp.	847-843-7500	www.niec.co.jp
Panasonic Corp.	800-344-2112	www.panasonic.com
SANYO Electric Co., Ltd.	619-661-6835	www.sanyo.com

Note: Indicate that you are using the MAX8792 when contacting these component suppliers.

Quick Start

Recommended Equipment

- 7V to 24V power supply, battery, or notebook AC adapter
- DC bias power supply, 5V at 100mA
- Dummy load capable of sinking 10A
- Digital multimeter (DMM)
- 100MHz dual-trace oscilloscope

MAX8792 Evaluation Kit

Evaluates: MAX8792

Procedure

The MAX8792 EV kit is fully assembled and tested. Follow the steps below to verify board operation. **Caution: Do not turn on the power supply until all connections are completed:**

- 1) Ensure that the circuit is connected correctly to the supplies and dummy load prior to applying any power.
- 2) Verify that the shunts are across JU1 pins 1-2 (EN high), JU2 pins uninstalled (1.5V output), and JU3 pins 1-2 (forced PWM).
- 3) Turn on battery power prior to +5V bias power; otherwise, the output undervoltage (UVP) FAULT latch will be set, disabling the regulator until +5V power is cycled below 0.5V or EN is toggled.
- 4) Observe the 1.5V output with the DMM and/or oscilloscope. Look at the LX switching node and MOSFET gate-drive signals while varying the load current.

Detailed Description of Hardware

Jumper Settings

Several jumper settings in the following tables illustrate some features of the MAX8792 EV kit.

Shutdown Control Input

The MAX8792 EV kit features a 3-pin jumper (JU1) that selects the shutdown control input. Table 1 lists the selectable jumper options.

External Gate

The MAX8792 EV kit features a 2-pin jumper (JU2) that controls the gate of the external MOSFET (N3). The external MOSFET can be controlled through the GATE test point to dynamically adjust the REF_{IN} voltage by forcing N3 to a low- or a high-impedance state. The default configuration has a shunt installed on only one pin of JU2 to provide a 1.5V output. Table 2 lists the selectable jumper options.

Pulse-Skipping Control Input

The MAX8792 EV kit features a 4-pin jumper (JU3) for pulse-skipping control input. This four-level input determines the mode of operation under normal steady-state conditions and dynamic output-voltage transitions. The default configuration has a shunt installed at pins 1-2 for low-noise forced-PWM mode. Table 3 lists the other selectable jumper options. Refer to the *Modes of Operation* section of the IC data sheet for a more detailed description.

Table 1. Jumper JU1 Functions

SHUNT POSITION	EN PIN	MAX8792 OUTPUT
1-2*	Connected to VDD	Enabled (V _{OUT} = 1.5V/1.05V)
2-3	Connected to GND	Shutdown mode (V _{OUT} = 0V)
Not installed	EN must be driven by an external signal connected to the EN test point	Operation depends on the external EN signal levels

*Default position.

Table 2. Jumper JU2 Functions

SHUNT POSITION	EXTERNAL GATE	MAX8792 OUTPUT
Installed	Connected to VDD	A logic-high on GATE turns on the external MOSFET, effectively shorting R3 (V _{OUT} = 1.05V through resistor-dividers R1 and R2).
Not installed*	Pulled to GND by R14	A logic-low on GATE turns off the external MOSFET (V _{OUT} = 1.5V through resistor-dividers R1 and R2 + R3).

*Default position.

Table 3. Jumper JU3 Functions

SHUNT POSITION	SKIP PIN	OPERATIONAL MODE
1-2*	Connected to VDD	Low-noise mode, forced-PWM operation
1-3	Connected to REF	Pulse-skipping mode with forced-PWM during transitions
1-4	Connected to GND	Pulse-skipping mode without forced-PWM during transitions
Not installed	Open	Ultrasonic mode without forced-PWM during transitions

*Default position.

MAX8792 Evaluation Kit

Evaluating Other Dynamic Output Voltages

The EV kit output is preset to 1.05V/1.5V. However, the output voltage can also be adjusted between 0 and 2V (FB = OUT) by selecting R1, R2, and R3 values. The MAX8792 regulates FB to the voltage set at REFIN. By changing the voltage at REFIN, the MAX8792 can be used in applications that require dynamic output voltage changes between two set points. Using the external GATE signal, a resistor can be switched in and out of the REFIN resistor-divider, changing the voltage at REFIN. A logic-high on GATE turns on the external n-channel MOSFET, forcing N3's drain to a low-impedance state. A logic-low on GATE disables the n-channel MOSFET, so N3's drain is high impedance. The two output voltages (FB = OUT) are determined by the following equations:

$$V_{OUT(LOW)} = \left(\frac{R2}{R1+R2} \right) V_{REF}$$

$$V_{OUT(HIGH)} = \left(\frac{R2+R3}{R1+R2+R3} \right) V_{REF}$$

where $V_{REF} = 2.0V$.

Setting V_{OUT} with a Resistive Voltage-Divider at FB

Connecting FB to a resistive voltage-divider allows for output voltages above the reference voltage (0 to $0.9 \times V_{IN}$ range). To get an output above 2V, install resistor R10 with a $10k\Omega \pm 1\%$ resistor and replace R9 with the following equation:

$$V_{OUT} = V_{FB} \left(1 + \frac{R9}{R10} \right)$$

where $V_{FB} = V_{REFIN}$.

The switching-frequency setting input should then be adjusted by replacing the external resistor R6 (R_{TON}) according to the following equations:

$$T_{SW} = C_{TON} (R_{TON} + 6.5k\Omega) \left(\frac{V_{FB}}{V_{OUT}} \right)$$

$$T_{SW} = \frac{1}{f_{SW}}$$

where $C_{TON} = 16.26pF$, $f_{SW} = 300kHz$, and $V_{FB} = V_{REFIN}$ under normal operating conditions. Refer to the MAX8792 data sheet for selection of output capacitor and inductor values for output voltages greater than 2V.

MAX8792 Evaluation Kit

Evaluates: MAX8792

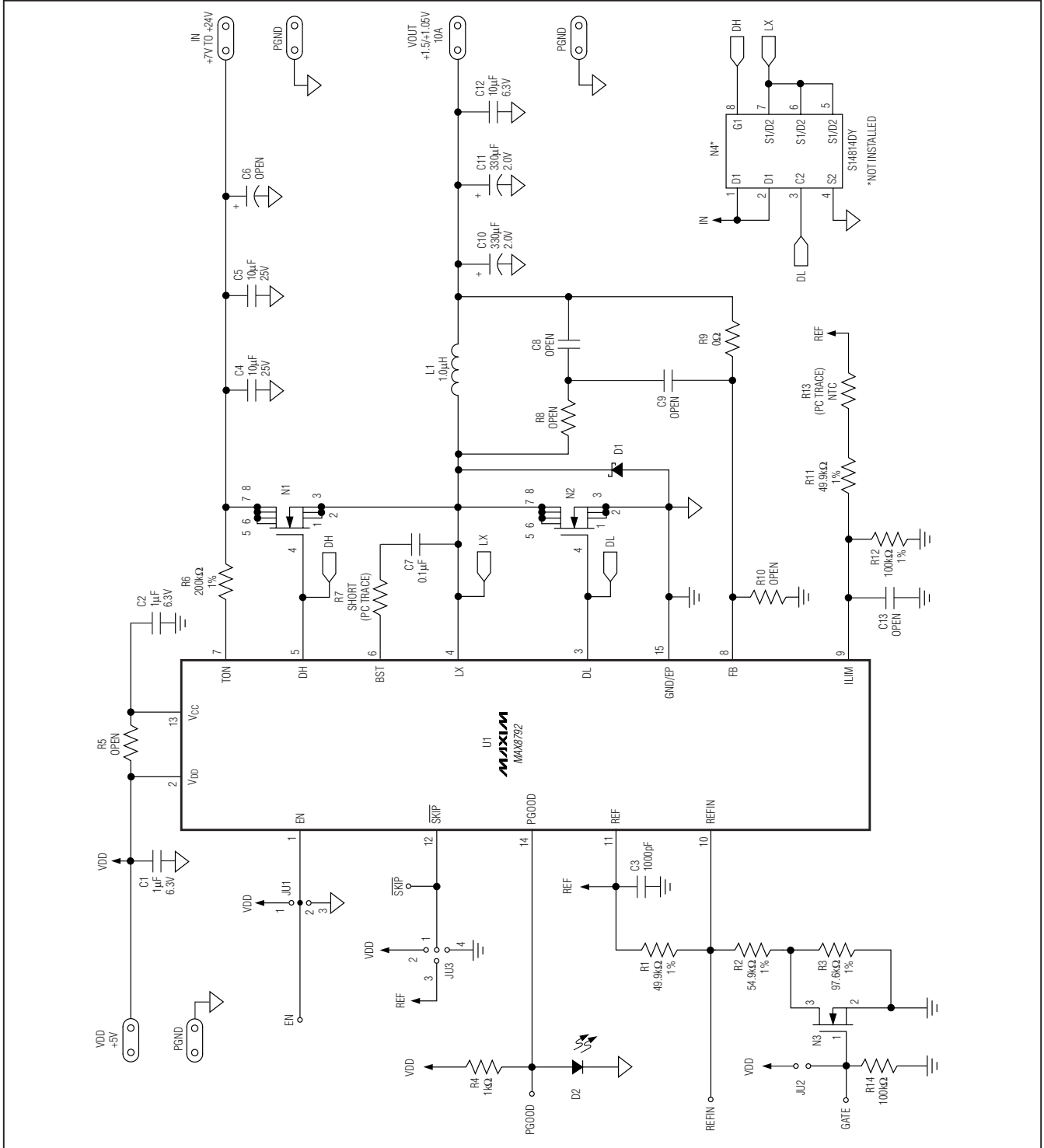

Figure 1. MAX8792 EV Kit Schematic

MAX8792 Evaluation Kit

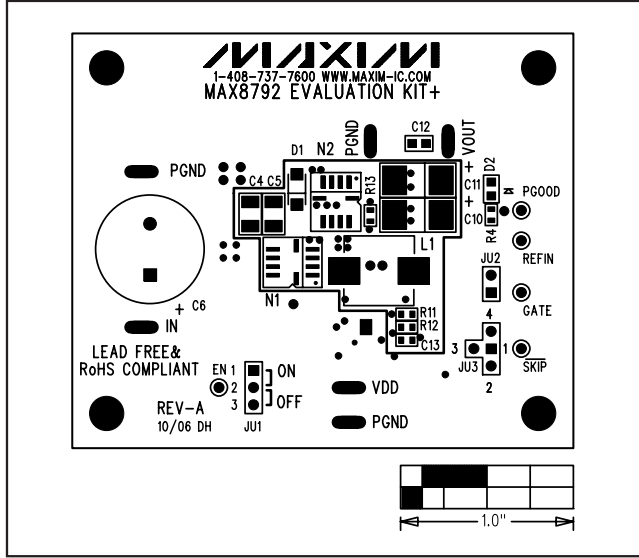

Figure 2. MAX8792 EV Kit Component Placement Guide—Component Side

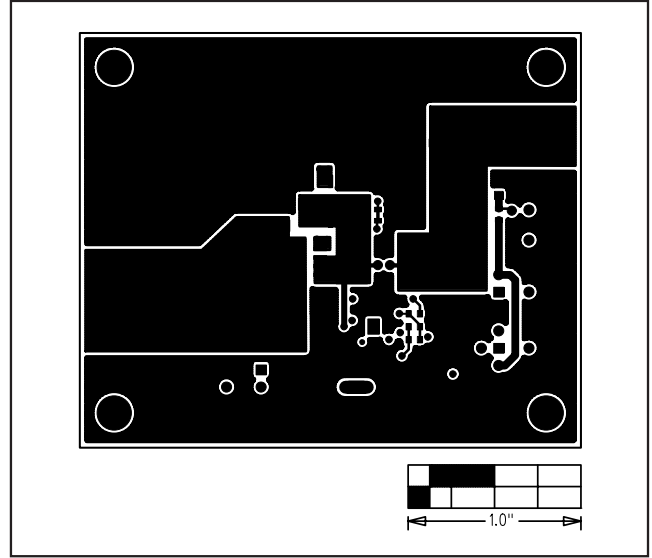

Figure 3. MAX8792 EV Kit PCB Layout—Component Side

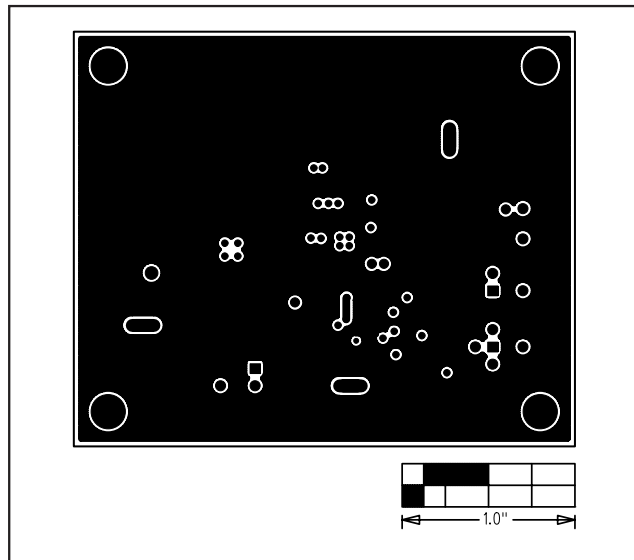

Figure 4. MAX8792 EV Kit PCB Layout—GND Layer 2

MAX8792 Evaluation Kit

Evaluates: MAX8792

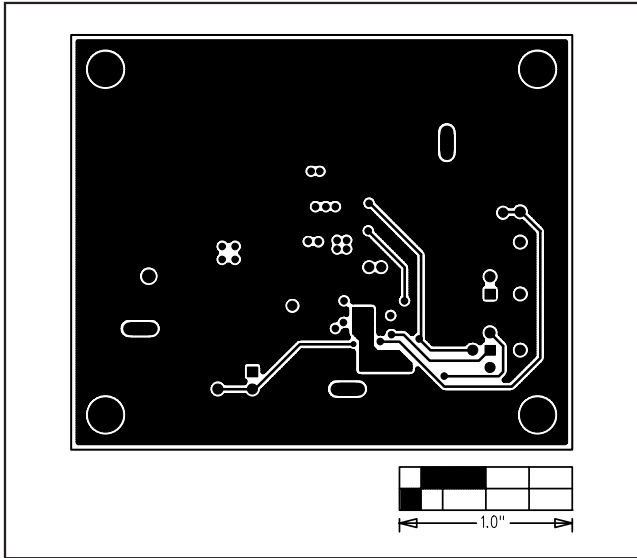

Figure 5. MAX8792 EV Kit PCB Layout—GND Layer 3

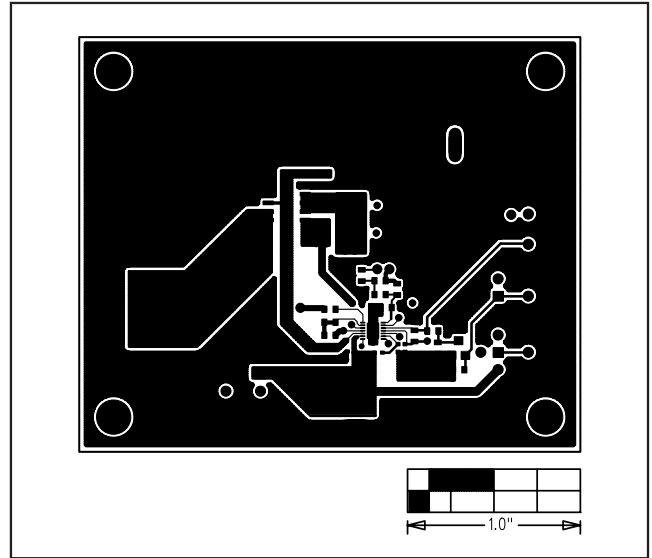

Figure 6. MAX8792 EV Kit PCB Layout—Solder Side

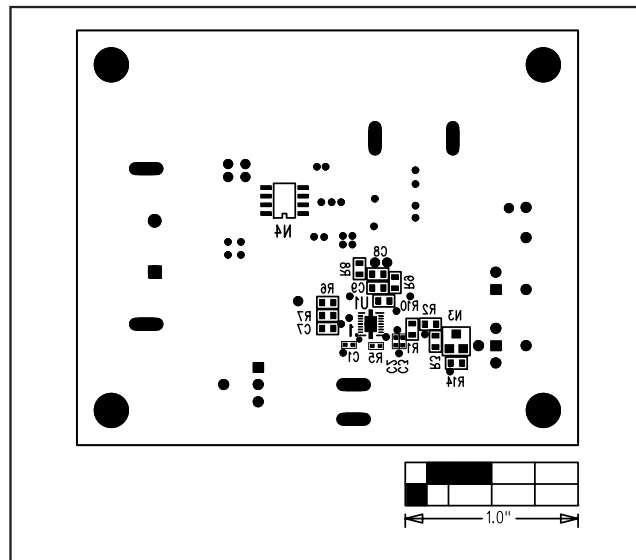

Figure 7. MAX8792 EV Kit Component Placement Guide—Solder Side

MAX8792 Evaluation Kit

Revision History

REVISION NUMBER	REVISION DATE	DESCRIPTION	PAGES CHANGED
0	4/07	Initial release	—
1	1/10	Correction made in the <i>Setting V_{OUT} with a Resistive Voltage-Divider at FB</i> section	4

Maxim cannot assume responsibility for use of any circuitry other than circuitry entirely embodied in a Maxim product. No circuit patent licenses are implied. Maxim reserves the right to change the circuitry and specifications without notice at any time.

8 **Maxim Integrated Products, 120 San Gabriel Drive, Sunnyvale, CA 94086 408-737-7600**

© 2010 Maxim Integrated Products

Maxim is a registered trademark of Maxim Integrated Products, Inc.

X-ON Electronics

Largest Supplier of Electrical and Electronic Components

Click to view similar products for [Power Management IC Development Tools](#) category:

Click to view products by [Maxim](#) manufacturer:

Other Similar products are found below :

[EVB-EP5348UI](#) [MIC23451-AAAYFL EV](#) [MIC5281YMME EV](#) [124352-HMC860LP3E](#) [DA9063-EVAL](#) [ADP122-3.3-EVALZ](#) [ADP130-0.8-EVALZ](#) [ADP130-1.8-EVALZ](#) [ADP1740-1.5-EVALZ](#) [ADP1870-0.3-EVALZ](#) [ADP1874-0.3-EVALZ](#) [ADP199CB-EVALZ](#) [ADP2102-1.25-EVALZ](#) [ADP2102-1.875EVALZ](#) [ADP2102-1.8-EVALZ](#) [ADP2102-2-EVALZ](#) [ADP2102-3-EVALZ](#) [ADP2102-4-EVALZ](#) [AS3606-DB](#) [BQ25010EVM](#) [BQ3055EVM](#) [ISLUSBI2CKIT1Z](#) [LP38512TS-1.8EV](#) [EVAL-ADM1186-1MBZ](#) [EVAL-ADM1186-2MBZ](#) [ADP122UJZ-REDYKIT](#) [ADP166Z-REDYKIT](#) [ADP170-1.8-EVALZ](#) [ADP171-EVALZ](#) [ADP1853-EVALZ](#) [ADP1873-0.3-EVALZ](#) [ADP198CP-EVALZ](#) [ADP2102-1.0-EVALZ](#) [ADP2102-1-EVALZ](#) [ADP2107-1.8-EVALZ](#) [ADP5020CP-EVALZ](#) [CC-ACC-DBMX-51](#) [ATPL230A-EK](#) [MIC23250-S4YMT EV](#) [MIC26603YJL EV](#) [MIC33050-SYHL EV](#) [TPS60100EVM-131](#) [TPS65010EVM-230](#) [TPS71933-28EVM-213](#) [TPS72728YFFEVM-407](#) [TPS79318YEQEVM](#) [UCC28810EVM-002](#) [XILINXPWR-083](#) [LMR22007YMINI-EVM](#) [LP38501ATJ-EV](#)