

# 1A, 97% Efficiency, 30 $\mu$ A Quiescent Current Step-Up Converter with True Shutdown

## General Description

The MAX8815A DC-DC step-up converter is a high-efficiency, low quiescent current, synchronous step-up converter with True Shutdown™ and inrush-current limiting. The MAX8815A generates any output voltage from 3.3V to 5V from a 2-cell NiMH/NiCd or a single-cell Li+/Li polymer battery.

The MAX8815A uses two modes of operation. The first mode of operation (normal) uses only 30 $\mu$ A (typ) quiescent current and allows the converter to switch only when needed at no load and light loads. Under moderate and heavy loads (typically above 90mA), the MAX8815A uses a fixed-frequency pulse-width modulation (PWM) technique. This mode allows maximum efficiency at light loads. The second mode of operation is a fixed-frequency forced-pulse-width modulation (FPWM) mode where the converter switches at a fixed frequency irrespective of the load. This mode allows for easy noise filtering and lower output ripple.

The MAX8815A has a preset 2.5A current limit, allowing 500mA load at 1.8V input and 1A load at 2.5V input when the output is set to 5V. Features include soft-start, which limits inrush current during startup, True Shutdown, and internal compensation. The MAX8815A is available in a compact 10-pin, 3mm x 3mm TDFN package.

The MAX8815A evaluation kit can help shorten the time required for system design.

## Applications

DSC and DVC  
Microprocessor/DSP Core Power  
Cell Phones, PDAs, MP3 Players  
Portable Handheld Devices  
PCMCIA Cards

*True Shutdown is a trademark of Maxim Integrated Products, Inc.*

## Pin Configuration

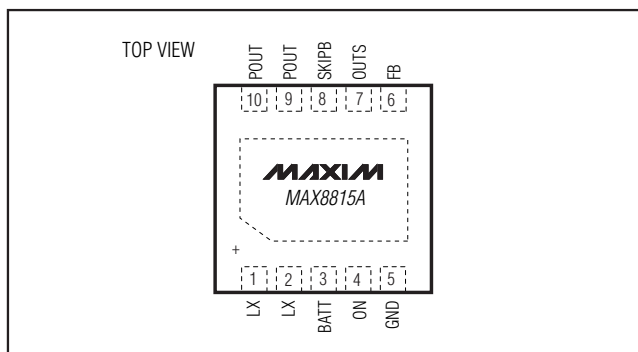

## Features

- ◆ Up to 97% Efficiency with Internal Synchronous Rectifier
- ◆ Low 30 $\mu$ A Quiescent Current
- ◆ Guaranteed 500mA Output Current at  $V_{OUT} = 5V$  from 1.8V Input
- ◆ Guaranteed 1A Output Current at 5V from 2.5V Input
- ◆ Low-Noise Constant Frequency Operation (FPWM Mode)
- ◆ 2MHz PWM Switching Frequency
- ◆ Preset (5V) or Adjustable Output
- ◆ Controlled Current in Soft-Start Limits Inrush Current
- ◆ True Shutdown
- ◆ Internal Compensation
- ◆ Overload/Short-Circuit Protection
- ◆ 0.1 $\mu$ A Shutdown Current
- ◆ Thermal Shutdown
- ◆ Compact 10-Pin, 3mm x 3mm TDFN Package

## Ordering Information

PART	PIN-PACKAGE	TOP MARK
MAX8815AETB+	10 TDFN-EP*	AUH

+Denotes a lead-free/RoHS-compliant package.

\*EP = Exposed pad.

**Note:** This device operates in the -40°C to +85°C extended operating temperature range.

## Simplified Operating Circuit

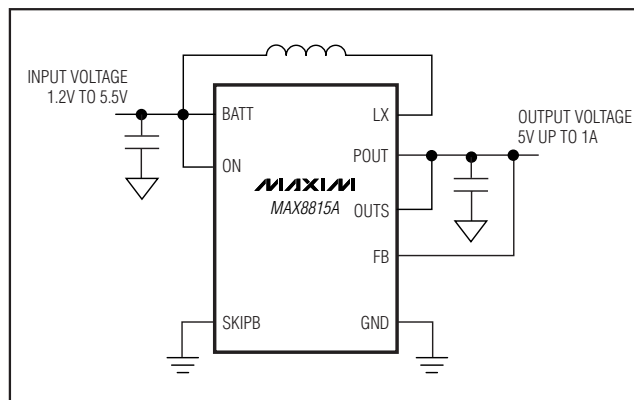

# 1A, 97% Efficiency, 30 $\mu$ A Quiescent Current Step-Up Converter with True Shutdown

## ABSOLUTE MAXIMUM RATINGS

OUTS, BATT to GND .....	-0.3V to +6V	10-Pin TDFN Multilayer Board (derate 24.4 mW/°C above +70°C).....	1951.2mW
POUT to OUTS .....	-0.3V to +0.3V	Junction-to-Case Thermal Resistance ( $\theta_{JC}$ ) (Note 2)	
PGND (EP) to AGND .....	-0.3V to +0.3V	10-Pin TDFN.....	8.5°C/W
FB to GND .....	-0.3V to (V <sub>OUT</sub> + 0.3V)	Junction-to-Ambient Thermal Resistance ( $\theta_{JA}$ ) (Note 2)	
ON, SKIPB to GND .....	-0.3V to the higher of (V <sub>OUTS</sub> + 0.3V) and (V <sub>BATT</sub> + 0.3V)	10-Pin TDFN.....	41°C/W
LX Continuous Current (Note 1).....	2.75A	Operating Temperature Range .....	-40°C to +85°C
Continuous Power Dissipation (T <sub>A</sub> = +70°C)		Junction Temperature Range .....	-40°C to +150°C
10-Pin TDFN Single-Layer Board (derate 18.5 mW/°C above +70°C).....	1481.5mW	Storage Temperature Range .....	-65°C to +150°C
		Lead Temperature (soldering, 10s).....	+300°C

Stresses beyond those listed under "Absolute Maximum Ratings" may cause permanent damage to the device. These are stress ratings only, and functional operation of the device at these or any other conditions beyond those indicated in the operational sections of the specifications is not implied. Exposure to absolute maximum rating conditions for extended periods may affect device reliability.

**Note 1:** LX has internal clamp diodes to PGND (EP) and VPWR, where VPWR is the internal power node and is the higher of BATT and OUTS. Applications that forward bias these diodes should take care not to exceed the power-dissipation limits of the device.

**Note 2:** Package thermal resistances were obtained using the method described in JEDEC specification JESD51-7, using a 4-layer board. For detailed information on package thermal considerations, visit [www.maxim-ic.com/thermal-tutorial](http://www.maxim-ic.com/thermal-tutorial).

## ELECTRICAL CHARACTERISTICS

(V<sub>OUTS</sub> = V<sub>POUT</sub> = 5V, V<sub>ON</sub> = V<sub>BATT</sub> = 3.6V, V<sub>SKIPB</sub> = GND, T<sub>A</sub> = -40°C to +85°C, typical values are at T<sub>A</sub> = +25°C, unless otherwise noted. Limits are 100% production tested at T<sub>A</sub> = +25°C. Limits over the operating temperature range are guaranteed by design and characterization.)

PARAMETER	CONDITIONS	MIN	TYP	MAX	UNITS	
<b>GENERAL</b>						
Operating Input Voltage Range		1.2		5.5	V	
Minimum Startup Voltage			1.2	1.5	V	
Shutdown Supply Current	ON = GND	T <sub>A</sub> = +25°C		0.1	1	$\mu$ A
		T <sub>A</sub> = +85°C		0.2		
Supply Current	No load, no switching, V <sub>FB</sub> = 1.28V		16	30	$\mu$ A	
	No load, switching (measured with external feedback); V <sub>POUT</sub> = 5V		30			
<b>OSCILLATOR</b>						
Switching Frequency		1.8	2.0	2.2	MHz	
Maximum Duty Cycle			87.5		%	
Output-Voltage Adjust Range		3.3		5.0	V	
FB Regulation Voltage	No load, T <sub>A</sub> = +25°C		1.255	1.265	1.275	V
	No load, T <sub>A</sub> = -40°C to +85°C (Note 3)		1.252	1.265	1.277	
FB Load Regulation			-7.5		mV/A	
FB Line Regulation	V <sub>BATT</sub> = 1.8V to 5V, I <sub>POUT</sub> = 0.5A		-10		mV/D	
FB Input Leakage Current	V <sub>FB</sub> = 1.28V, V <sub>OUTS</sub> = V <sub>POUT</sub> = V <sub>BATT</sub> = 5.5V	T <sub>A</sub> = +25°C		-50	-5	nA
		T <sub>A</sub> = +85°C			-5	
Idle Mode™ Trip Level	(Note 4)		90		mA	

Idle Mode is a trademark of Maxim Integrated Products, Inc.

# 1A, 97% Efficiency, 30μA Quiescent Current Step-Up Converter with True Shutdown

MAX8815A

## ELECTRICAL CHARACTERISTICS (continued)

( $V_{OUTS} = V_{POUT} = 5V$ ,  $V_{ON} = V_{BATT} = 3.6V$ ,  $V_{SKIPB} = GND$ ,  $T_A = -40^{\circ}C$  to  $+85^{\circ}C$ , typical values are at  $T_A = +25^{\circ}C$ , unless otherwise noted. Limits are 100% production tested at  $T_A = +25^{\circ}C$ . Limits over the operating temperature range are guaranteed by design and characterization.)

PARAMETER	CONDITIONS	MIN	TYP	MAX	UNITS
<b>DC-DC SWITCHES</b>					
p-Channel On-Resistance			0.14	0.25	Ω
n-Channel On-Resistance			0.1	0.17	Ω
n-Channel Current Limit		2.20	2.5	2.75	A
p-Channel Turn-Off Current			10		mA
OUT Leakage Current	$V_{LX} = V_{ON} = 0V$ , $V_{OUTS} = V_{POUT} = V_{BATT} = 5.5V$		0.1	2	μA
			0.2		
LX Leakage Current	$V_{LX} = 0V$ or $5.5V$ , $V_{OUTS} = V_{POUT} = V_{BATT} = 5.5V$ , $V_{ON} = 0V$		0.1	2	μA
			0.2		
Soft-Start Interval	Load dependent		6		ms
Overload Protection Fault Delay			16		ms
Startup into a Short Circuit			6		ms
<b>LOGIC INPUTS</b>					
ON Input Low Level	$V_{OUTS} = V_{POUT} = 0V$ and $1.5V < V_{BATT} < 5.5V$			0.5	V
ON Input High Level	$V_{OUTS} = V_{POUT} = 0V$ and $1.5V < V_{BATT} < 5.5V$ , $V_H$ is the higher of $V_{POUT}$ and $V_{BATT}$		$V_H - 0.2V$ (1.3V max)		V
SKIPB Input Low Level	$3.3V < V_{POUT} < V_{OUT} < 5.5V$			0.5	V
SKIPB Input High Level	$3.3V < V_{POUT} < V_{OUT} < 5.5V$		1.6		V
ON, SKIPB Input Leakage Current	$V_{OUTS} = V_{POUT} = V_{BATT} = 5.5V$		0.01	1	μA
			0.02		
Thermal Shutdown			+167		°C

**Note 3:** Guaranteed by design. Not production tested.

**Note 4:** The idle-mode current threshold is the transition point between fixed-frequency PWM operation and idle-mode operation. The specification is given in terms of output load current for inductor values shown in the typical application circuits (Figure 1). The idle-mode transition varies with input-to-output voltage ratio.

# 1A, 97% Efficiency, 30µA Quiescent Current Step-Up Converter with True Shutdown

## Typical Operating Characteristics

( $V_{OUTS} = V_{POUT} = 5V$ ,  $V_{BATT} = V_{ON} = 3.6V$ ,  $V_{SKIPB} = GND$ .)

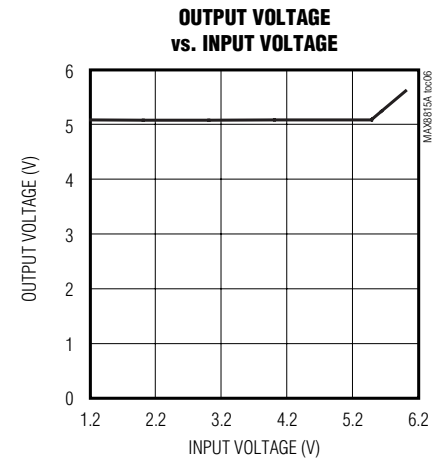
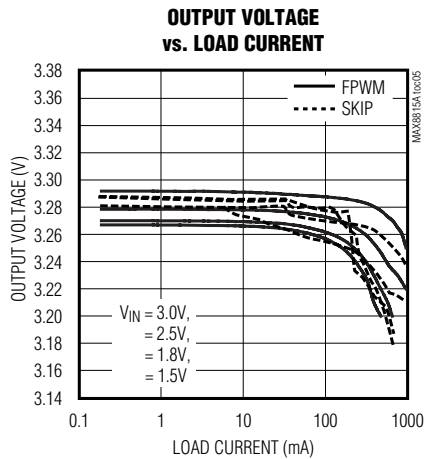
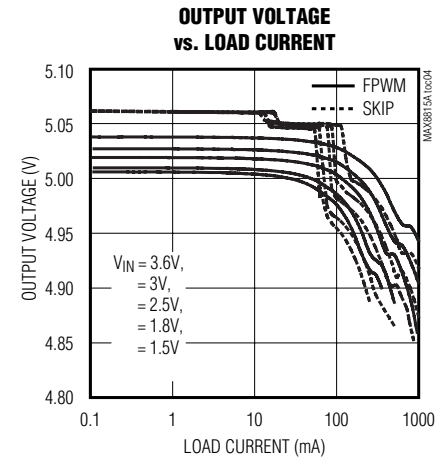
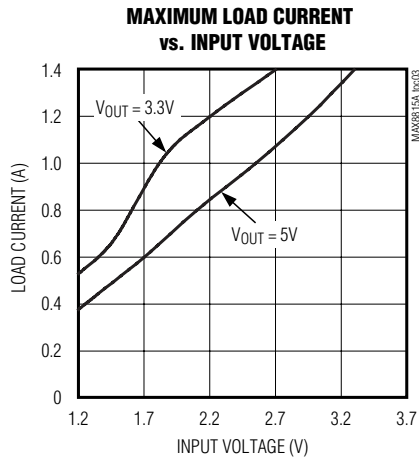
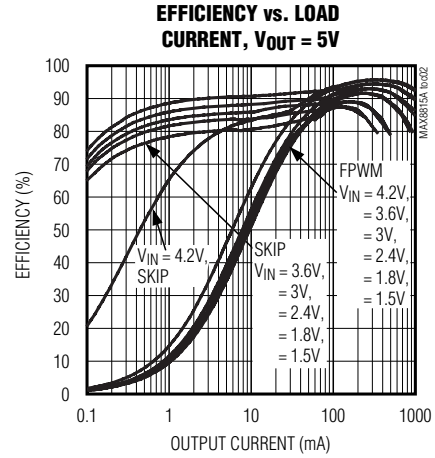
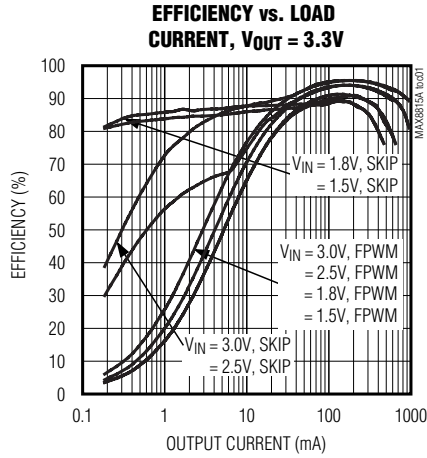

# 1A, 97% Efficiency, 30 $\mu$ A Quiescent Current Step-Up Converter with True Shutdown

## Typical Operating Characteristics (continued)

( $V_{OUTS} = V_{POUT} = 5V$ ,  $V_{BATT} = V_{ON} = 3.6V$ ,  $V_{SKIPB} = GND$ .)

**MAX8815A**

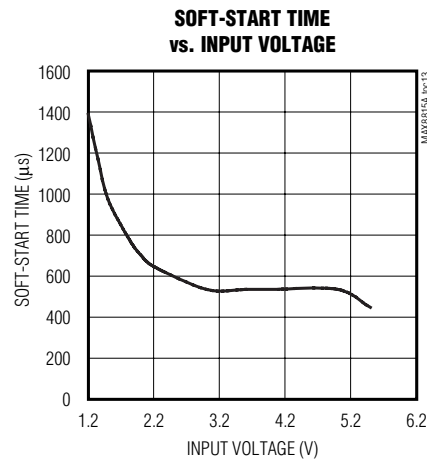
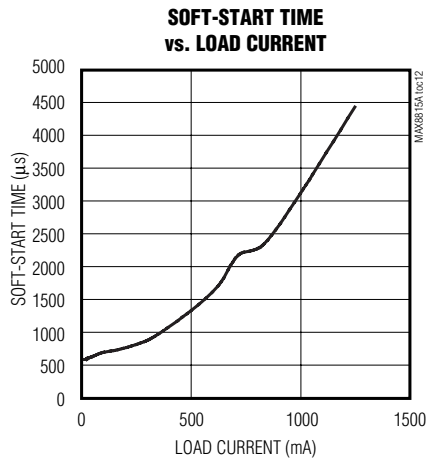
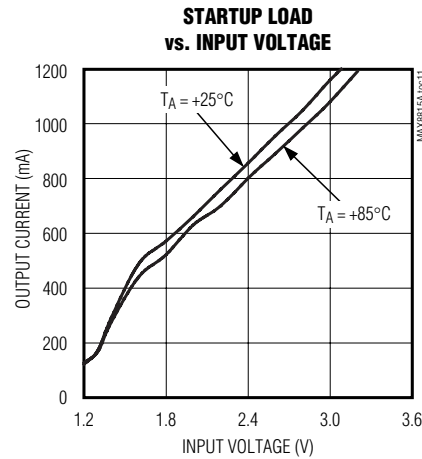
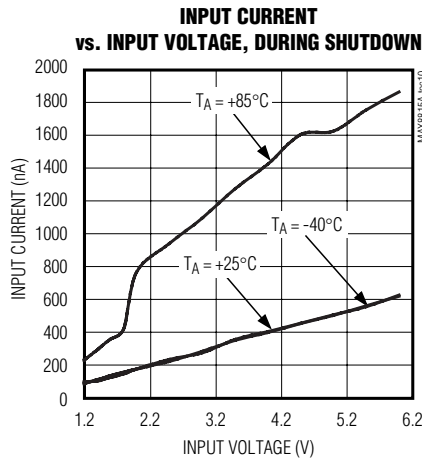
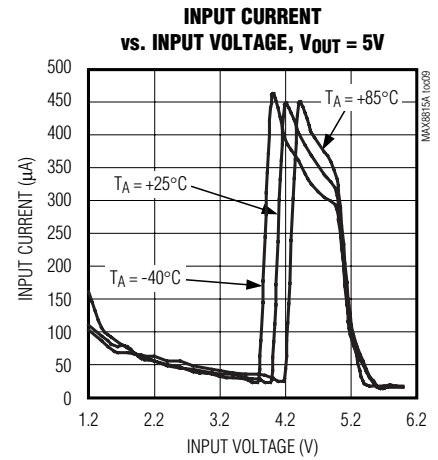
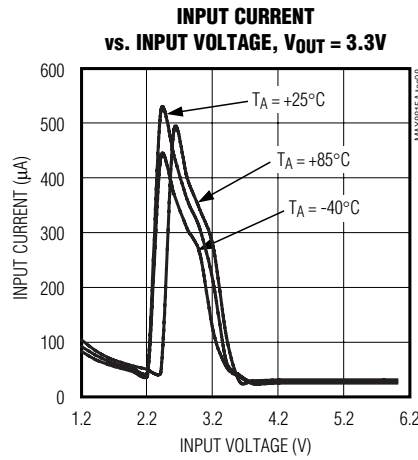
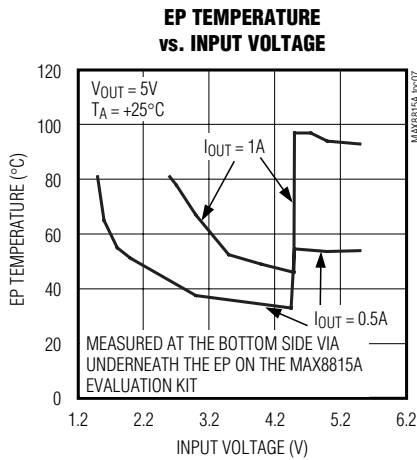

# 1A, 97% Efficiency, 30 $\mu$ A Quiescent Current Step-Up Converter with True Shutdown

## Typical Operating Characteristics (continued)

( $V_{OUTS} = V_{POUT} = 5V$ ,  $V_{BATT} = V_{ON} = 3.6V$ ,  $V_{SKIPB} = GND$ .)

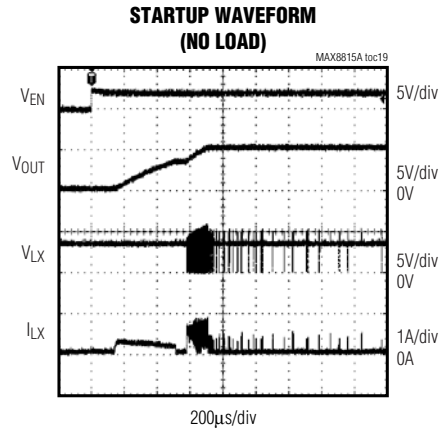
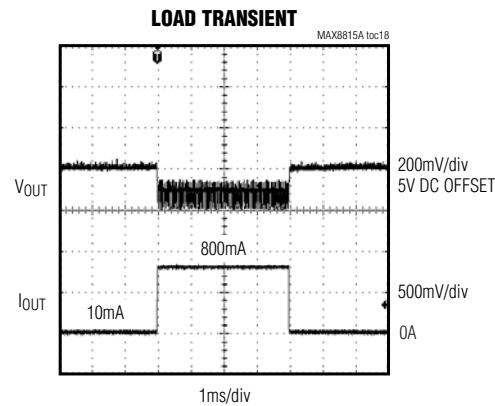
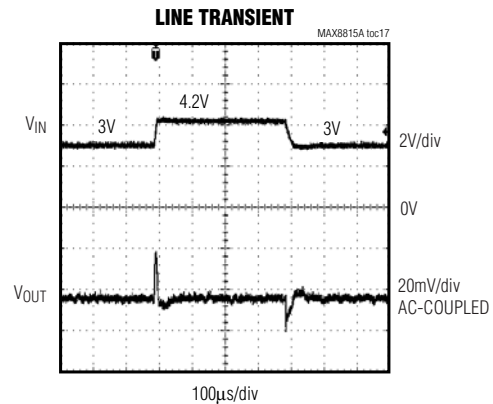
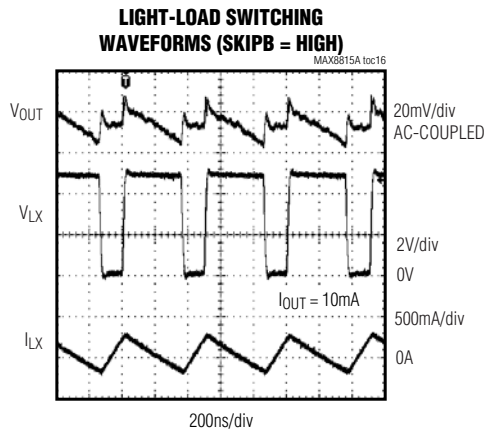
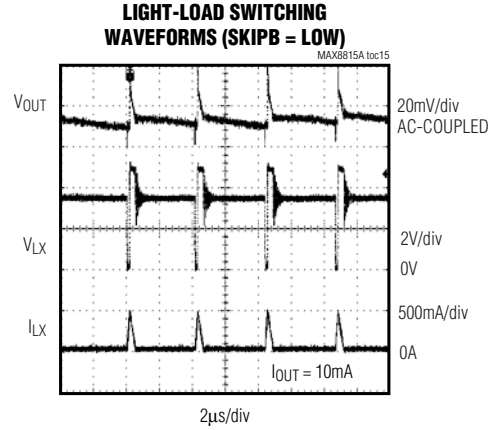
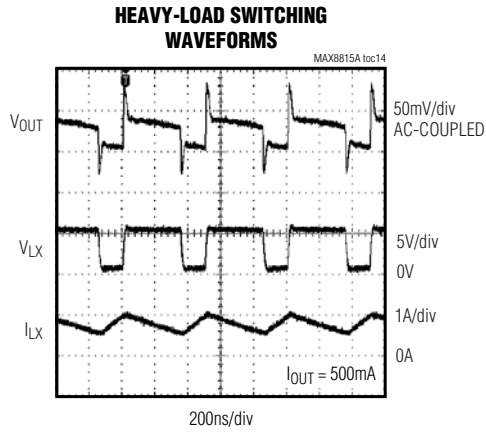

# 1A, 97% Efficiency, 30 $\mu$ A Quiescent Current Step-Up Converter with True Shutdown

## Pin Description

PIN	NAME	FUNCTION
1, 2	LX	Inductor Connection. LX pins are internally connected. Connect the LX pins to the switched side of the inductor. LX is high impedance in shutdown.
3	BATT	Supply Voltage Input. Connect BATT to an input supply between 1.2V and 5V. Bypass BATT to EP with two 4.7 $\mu$ F ceramic capacitors or one 10 $\mu$ F ceramic capacitor.
4	ON	Logic On/Off Input. Drive ON low to place the MAX8815A into shutdown. During shutdown, the control circuitry, internal switching MOSFET, and synchronous rectifier turn off and LX becomes high impedance. Drive ON high for normal operation.
5	GND	Analog Ground
6	FB	Feedback Input. Connect FB to POUT to set $V_{OUT} = 5V$ . For other output voltages, connect a resistor-divider from POUT to GND (see the <i>Setting the Output Voltage</i> section). FB regulates to 1.265V (typ) and is high impedance in shutdown.
7	OUTS	Power Bootstrapped Input. Connect OUTS to POUT through an RC filter.
8	SKIPB	PWM Mode Selection Input. Drive SKIPB low to select the normal mode of operation. Normal mode is fixed PWM at medium to heavy loads and skip mode at light loads. Drive SKIPB high to select the forced-PWM mode of operation.
9, 10	POUT	Converter Output. Bypass POUT to EP with one 22 $\mu$ F tantalum capacitor.
—	EP	Exposed Paddle. Connect to the ground plane to optimize thermal performance. EP is internally connected to GND. EP must be connected to GND at a single point with a star ground connection.

**MAX8815A**

# 1A, 97% Efficiency, 30 $\mu$ A Quiescent Current Step-Up Converter with True Shutdown

## Functional Diagram

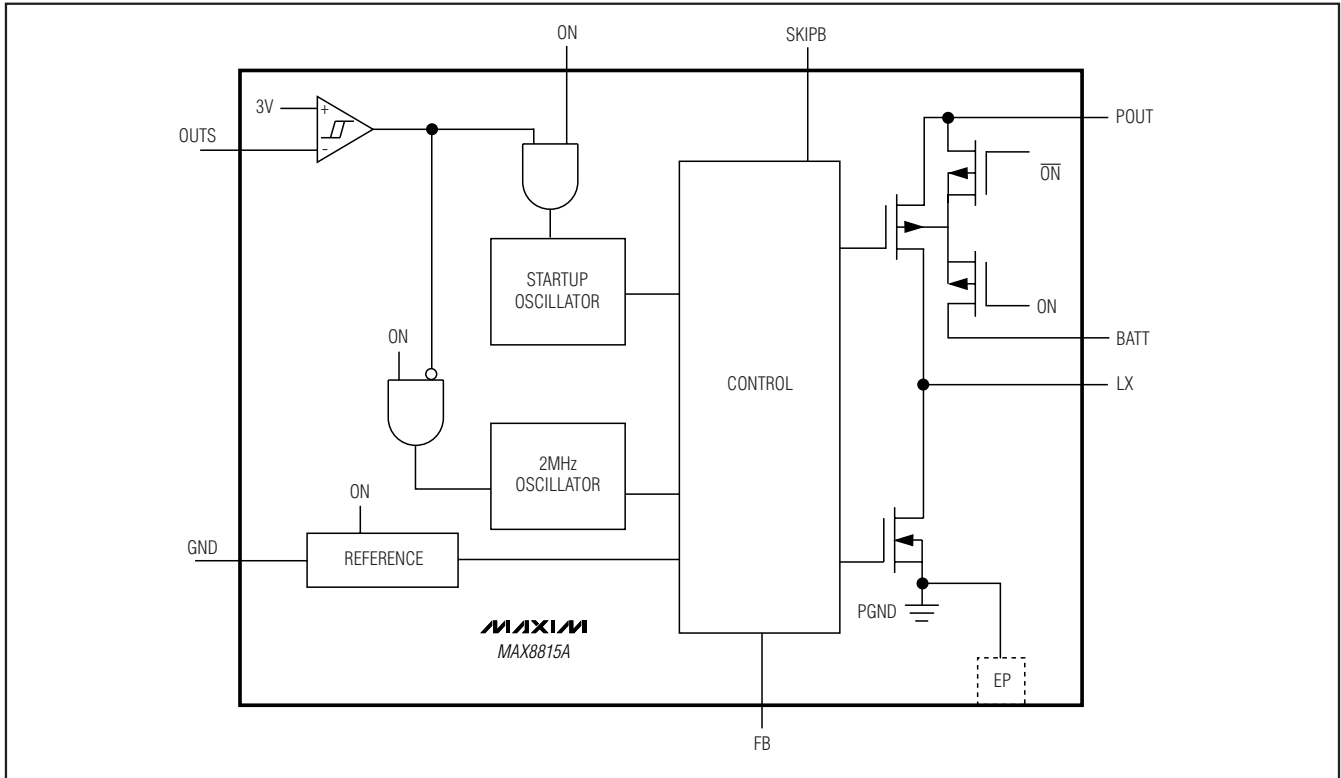

### Detailed Description

The MAX8815A current-mode step-up DC-DC switching converter uses a fixed-frequency PWM architecture with True Shutdown. In normal mode, the converter switches when needed, consuming only 30 $\mu$ A of quiescent current. In forced-PWM mode (FPWM), the converter switches every cycle at a constant frequency, thus enabling noise filtering. The MAX8815A is highly efficient, with an internal switch and synchronous rectifier. Shutdown reduces the quiescent current to less than 0.1 $\mu$ A. Low quiescent current and high efficiency make this device ideal for powering portable equipment.

The MAX8815A step-up DC-DC switching converter typically generates a 3.3V to 5V output voltage from a 1.2V to 5.5V battery input voltage. The converter operates in

bootstrapped mode with the output powering the device once the output voltage is  $\geq 3$ V. The current limit is set at 2.5A to deliver 1A at 5V from a 2.5V input, or 500mA at 5V using a 2-cell 1.8V input. Internal soft-start limits the inrush current to less than 500mA under no-load conditions during startup.

The MAX8815A switches at a 2MHz frequency, allowing for tiny external components. Internal compensation further reduces the external component count in cost and space-sensitive applications. The MAX8815A is optimized for use in DSC and other applications requiring low quiescent current for maximum battery life. Figures 1a and 1b show the typical application circuits.



# 1A, 97% Efficiency, 30 $\mu$ A Quiescent Current Step-Up Converter with True Shutdown

MAX8815A

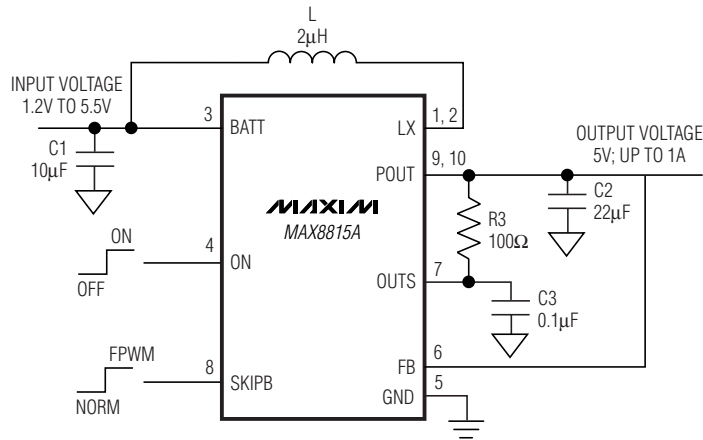

1a. FIXED 5V OUTPUT

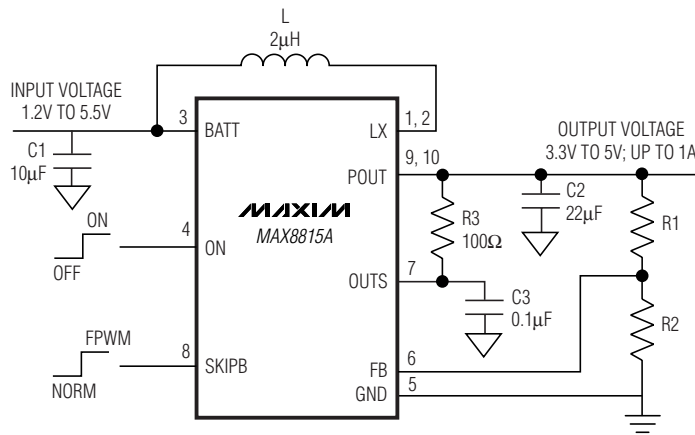

1b. ADJUSTABLE OUTPUT VOLTAGE

Figure 1. Typical Application Circuits

# 1A, 97% Efficiency, 30 $\mu$ A Quiescent Current Step-Up Converter with True Shutdown

## DC-DC Converter

The MAX8815A uses a current-mode PWM control scheme. The voltage difference between FB and an internal 1.265V (typ) reference generates an error signal that programs the peak inductor current to regulate the output voltage. The default peak-inductor current limit is 2.5A (typ). Inductor current is sensed across the internal switch and summed with a slope-compensation signal. The PWM comparator compares this summed signal to the error-amplifier output. At the beginning of each clock cycle, the n-channel switch turns on until the PWM comparator trips. During this time, inductor current ramps up, storing energy in its magnetic field. When the n-channel switch turns off, the internal synchronous p-channel rectifier turns on. The inductor releases the stored energy as the current ramps down and provides energy to the output. The MAX8815A operates in two modes, normal mode and FPWM mode, depending on the voltage at SKIPB.

### Normal Mode

Drive SKIPB low to select the normal mode of operation. In this mode, the device operates in PWM only when driving medium to heavy loads. As the load current decreases and crosses the low-power idle-mode threshold, the PWM comparator and oscillator are disabled. In this low-power mode, switching occurs only as needed to service the output. This improves the efficiency for light loads, and the device consumes only 30 $\mu$ A under no-load conditions. The threshold for entering skip mode is approximately 90mA load with a 3.6V input and 5V output. When switching in normal mode, the inductor current terminates at zero for each switching cycle.

### FPWM Mode

Drive SKIPB high to select the MAX8815A's FPWM mode of operation. The IC switches at a constant frequency (2MHz) and modulates the MOSFET switch pulse width to control the power transferred per cycle to regulate the output voltage. Switching harmonics generated by fixed-frequency operation are consistent and easily filtered. This is important in noise-sensitive applications.

The MAX8815A does not allow for dynamic switching between normal and FPWM modes.

## Load-Transient Response/ Voltage Positioning

The MAX8815A matches the load regulation to the voltage droop seen during load transients. This is sometimes called voltage positioning. Benefits include lower peak-to-peak output-voltage deviation for a given load step without requiring an increase in filter load capacitance. There is minimal voltage droop when transitioning from light load to full load and minimum overshoot when going from full load to light load.

The term "positioning" refers to setting the output voltage to a level that is dependent on load current (Figure 2). At minimum load, the output voltage is set to a slightly higher than nominal level. At full load, the output voltage is slightly lower than the nominal level. With voltage positioning, the total voltage deviation during a transient is significantly improved over traditional high-gain control loops. Traditional high-gain loops use integrators that maximize gain at low frequencies to provide tight DC-load regulation; however, due to the capacitive element in the feedback loop, these high-gain amplifiers typically take hundreds of microseconds to respond to a load step and return to steady state. As a result, the voltage can droop by as much as 6% or more during the recovery time. In portable equipment where the output load can change frequently and the amount of output capacitance is limited, this can result in a wide short-term output fluctuation (Figure 3).

Voltage positioning on the MAX8815A allows up to 3% (typ) of load regulation and no further transient droop (Figures 2 and 3). Thus, during load transients the voltage delivered remains within specification more effectively than other regulators that might have tighter DC accuracy. In systems with high-speed CPUs, thousands of system clock cycles can occur during the time it takes a traditional high-gain loop to respond to a load step. Consequently, 3% load regulation with no transient droop is better suited to such systems than a power supply that may specify 1% DC-load regulation, but then exhibits 6% or more of transient droop during load steps (see the Load Transient graph in the *Typical Operating Characteristics* section).

# 1A, 97% Efficiency, 30µA Quiescent Current Step-Up Converter with True Shutdown

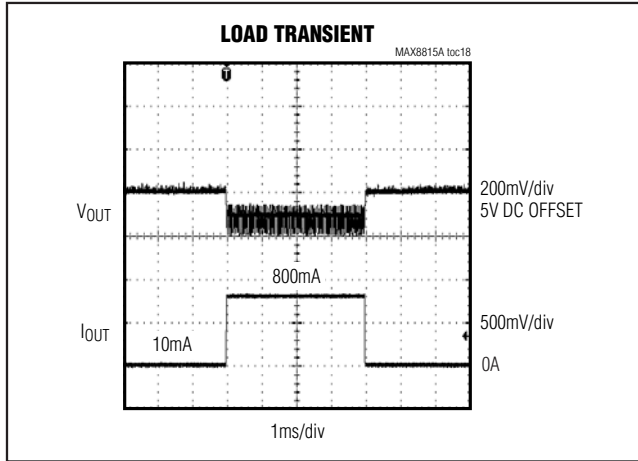

Figure 2. Load Regulation

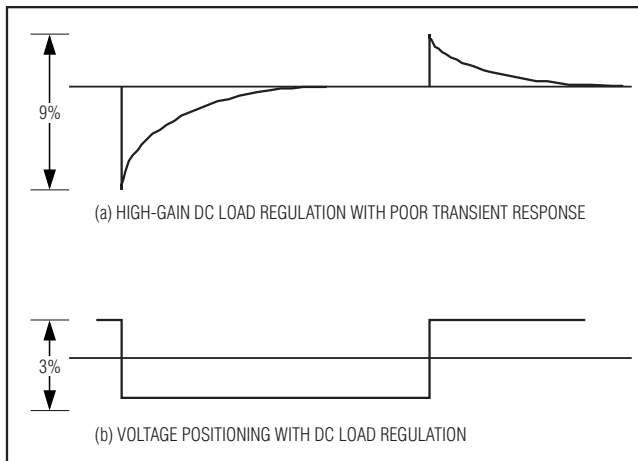

Figure 3. Transient-Response Comparison

### True Shutdown

Drive ON low to place the MAX8815A in shutdown mode and reduce supply current to 0.1µA (typ). In shutdown, the control circuitry, internal switching MOSFET, and synchronous rectifier turn off and LX becomes high impedance. Drive ON high for normal operation. The internal synchronous rectifier allows for conversion efficiencies as high as 97%. In conventional step-up circuits, the body diode of the synchronous rectifier is forward biased in shutdown and allows current flow from the battery to the output. If the load cannot be

shut down, an external switch is required to avoid depleting the battery during shutdown. A proprietary design in the MAX8815A allows the synchronous rectifier to provide True Shutdown with no additional components. This allows the output to fall to GND in shutdown and removes any connection between the input and output.

### Soft-Start

The MAX8815A has internal soft-start circuitry that controls inrush current at startup, reducing transients on the input source. Soft-start is particularly useful for higher impedance input sources, such as Li+ and alkaline cells. The soft-start duration is proportional to the size of the output capacitor and load resistance. See the *Typical Operating Characteristics* section for plots of Soft-Start Time vs. Load Current and Soft-Start Time vs. Input Voltage.

### Fault Protection

The MAX8815A has robust fault and overload protection. After power-up, the device monitors for an out-of-regulation state such as an overload or short-circuit condition. If the converter remains faulted for 16ms, the output latches off until the part is reinitialized by toggling ON or cycling power to the IC. If the output falls 10% below its regulation voltage or is shorted, the device enters the fault state immediately.

If the short exists on the output before the IC is powered up, the converter goes through soft-start once and then latches off (6ms) because the output never reaches regulation. The part draws about 1A of input current during the startup period. Limiting the time under this condition prevents thermal runaway.

## Applications Information

### Setting the Output Voltage

The MAX8815A has a preset output voltage of 5V. To set other output voltages, use external feedback resistors.

To set the output voltage between 3.3V and 5V, connect FB to the center of an external resistor voltage-divider between POUT and GND, as shown in Figure 1b. Select the value of R2 no more than 500kΩ, and then calculate the value for R1 as follows:

$$R1 = R2 (V_{OUT}/V_{FB} - 1)$$

where  $V_{FB}$  is the FB regulation voltage, 1.265V (typ).

# 1A, 97% Efficiency, 30 $\mu$ A Quiescent Current Step-Up Converter with True Shutdown

## Inductor Selection

In most step-up converter designs, a reasonable inductor value can be derived from the following equation. This equation sets peak-to-peak inductor current at 1/2 the DC inductor current:

$$L = (2 \times V_{BATT} \times D \times (1 - D)) / (I_{OUT(MAX)} \times f_{SW})$$

where  $f_{SW}$  is the switching frequency (2MHz), and D is the duty factor given by  $D = 1 - (V_{BATT}/V_{OUT})$ . Using L from the equation above results in a peak-to-peak inductor current ripple of  $0.5 \times I_{OUT}/(1 - D)$ , and a peak inductor current of  $1.25 \times I_{OUT}/(1 - D)$ . Ensure that the peak (saturation) current rating of the inductor meets or exceeds this requirement. The recommended inductance range for the MAX8815A is 1 $\mu$ H to 2.2 $\mu$ H. See Table 1 for recommended inductors.

## Capacitor Selection

### Output Capacitor

Output capacitor C2 in Figures 1a and 1b is required to keep the output voltage ripple small and to ensure regulation loop stability. The output capacitors must have low impedance at the switching frequency. Make sure the output capacitors maintain their capacitance over DC bias and the desired operating temperature range. One 22 $\mu$ F tantalum capacitor is recommended.

### Input Capacitor

Input capacitor C1 reduces the current peaks drawn from the battery or input power source and reduce switching noise in the IC. The impedance of the input capacitor at the switching frequency should be kept very low. A ceramic capacitor is highly recommended due to their small size and low ESR. Make sure the input capacitors maintain their capacitance over DC bias and the desired operating temperature range. Ceramic capacitors with X5R or X7R dielectric temperature characteristics generally perform well. Two 4.7 $\mu$ F or one 10 $\mu$ F ceramic capacitors are recommended.

Table 1. Recommended Inductors

INDUCTOR	L ( $\mu$ H)	DCR (m $\Omega$ )	I <sub>SAT</sub> (A)	SIZE (mm)
TOKO DE4012CK A1101AS-1R0M	1	45	3.3	4 x 4 x 1.2
TOKO DE4012CK A1101AS-2R2M	2.2	60	2.8	4 x 4 x 1.2
TOKO 2818C 1072AS-1R0M	1	40	2.8	2.8 x 2.8 x 1.8

## PCB Layout and Routing

Good printed-circuit board (PCB) layout is important to achieve optimal performance for the MAX8815A. Poor design can cause excessive conducted and radiated noise. Conductors carrying discontinuous currents and any high-current path should be made as short and wide as possible. Keep the feedback network (R1 and R2) very close to the IC, preferably within 0.2in of the FB and GND pins. Nodes with high dV/dt (switching nodes) should be kept as small as possible and routed away from FB. Connect the input and output capacitors as close as possible to the IC. Refer to the MAX8815A EV kit data sheet for a PCB layout example.

## Chip Information

PROCESS: BiCMOS

# 1A, 97% Efficiency, 30 $\mu$ A Quiescent Current Step-Up Converter with True Shutdown

## Package Information

For the latest package outline information and land patterns, go to [www.maxim-ic.com/packages](http://www.maxim-ic.com/packages).

**MAX8815A**

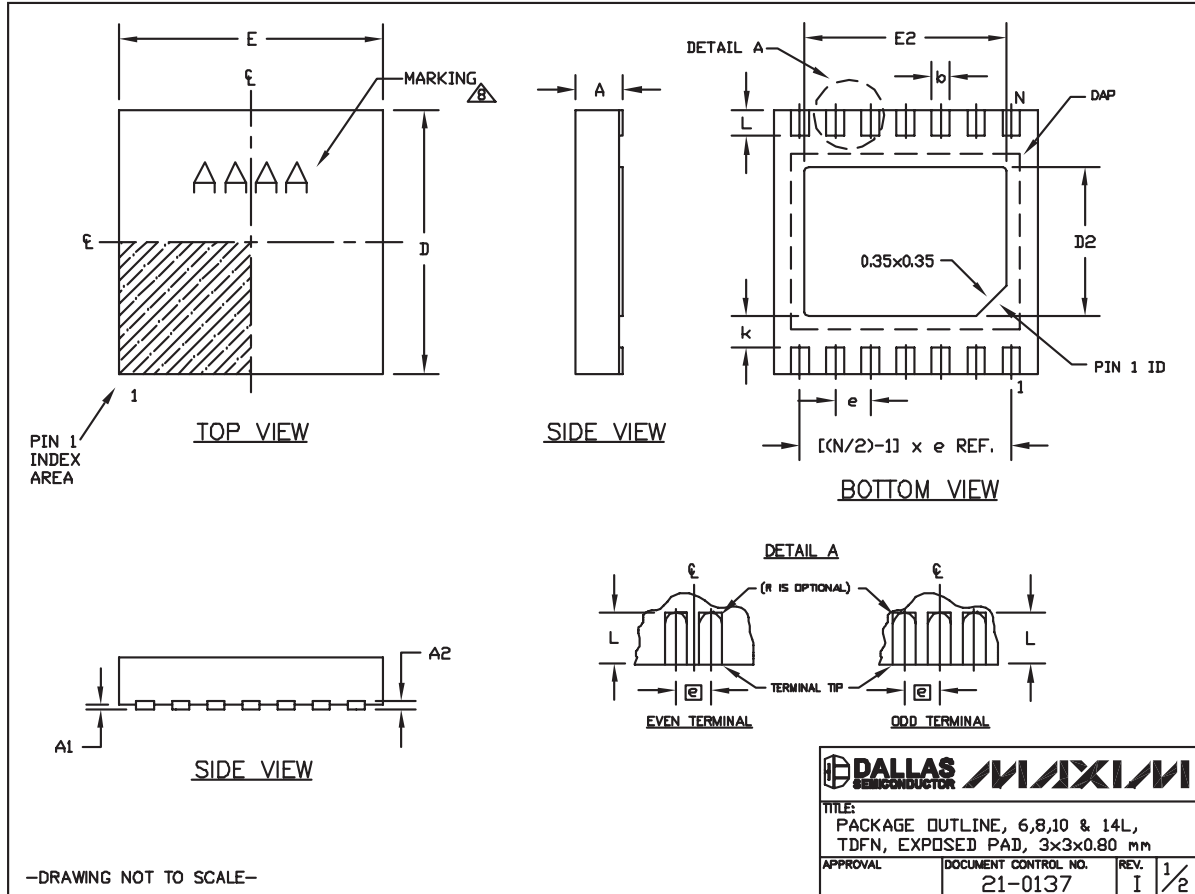

# 1A, 97% Efficiency, 30µA Quiescent Current Step-Up Converter with True Shutdown

## Package Information (continued)

For the latest package outline information and land patterns, go to [www.maxim-ic.com/packages](http://www.maxim-ic.com/packages).

COMMON DIMENSIONS			PACKAGE VARIATIONS							
SYMBOL	MIN.	MAX.	PKG. CODE	N	D2	E2	e	JEDEC SPEC	b	[(N/2)-1] x e
A	0.70	0.80	T633-2	6	1.50±0.10	2.30±0.10	0.95 BSC	MO229 / WEEA	0.40±0.05	1.90 REF
D	2.90	3.10	T833-2	8	1.50±0.10	2.30±0.10	0.65 BSC	MO229 / WEEC	0.30±0.05	1.95 REF
E	2.90	3.10	T833-3	8	1.50±0.10	2.30±0.10	0.65 BSC	MO229 / WEEC	0.30±0.05	1.95 REF
A1	0.00	0.05	T1033-1	10	1.50±0.10	2.30±0.10	0.50 BSC	MO229 / WEED-3	0.25±0.05	2.00 REF
L	0.20	0.40	T1033-2	10	1.50±0.10	2.30±0.10	0.50 BSC	MO229 / WEED-3	0.25±0.05	2.00 REF
k	0.25 MIN.		T1433-1	14	1.70±0.10	2.30±0.10	0.40 BSC	----	0.20±0.05	2.40 REF
A2	0.20 REF.		T1433-2	14	1.70±0.10	2.30±0.10	0.40 BSC	----	0.20±0.05	2.40 REF

NOTES:

1. ALL DIMENSIONS ARE IN mm. ANGLES IN DEGREES.
2. COPLANARITY SHALL NOT EXCEED 0.08 mm.
3. WARPAGE SHALL NOT EXCEED 0.10 mm.
4. PACKAGE LENGTH/PACKAGE WIDTH ARE CONSIDERED AS SPECIAL CHARACTERISTIC(S).
5. DRAWING CONFORMS TO JEDEC MO229, EXCEPT DIMENSIONS "D2" AND "E2", AND T1433-1 & T1433-2.
6. "N" IS THE TOTAL NUMBER OF LEADS.
7. NUMBER OF LEADS SHOWN ARE FOR REFERENCE ONLY.
8. MARKING IS FOR PACKAGE ORIENTATION REFERENCE ONLY.

—DRAWING NOT TO SCALE—

TITLE:  
PACKAGE OUTLINE, 6,8,10 & 14L,  
TDFN, EXPOSED PAD, 3x3x0.80 mm

APPROVAL	DOCUMENT CONTROL NO. 21-0137	REV. I	2/2
----------	---------------------------------	-----------	-----

PACKAGE TYPE	PACKAGE CODE	DOCUMENT NO.
10 TDFN-EP	T1033-2	<a href="#">21-0137</a>

# 1A, 97% Efficiency, 30 $\mu$ A Quiescent Current Step-Up Converter with True Shutdown

## Revision History

REVISION NUMBER	REVISION DATE	DESCRIPTION	PAGES CHANGED
0	5/08	Initial release	—
1	8/08	Modified <i>Operating Circuit</i> title ( <i>Typical</i> to <i>Simplified</i> ), updated TOCs 1, 5, 8, 9, and corrected inductor values	1, 4, 5, 9

MAX8815A

Maxim cannot assume responsibility for use of any circuitry other than circuitry entirely embodied in a Maxim product. No circuit patent licenses are implied. Maxim reserves the right to change the circuitry and specifications without notice at any time.

Maxim Integrated Products, 120 San Gabriel Drive, Sunnyvale, CA 94086 408-737-7600 \_\_\_\_\_ 15

## X-ON Electronics

Largest Supplier of Electrical and Electronic Components

*Click to view similar products for [Switching Voltage Regulators](#) category:*

*Click to view products by [Maxim](#) manufacturer:*

Other Similar products are found below :

[FAN53610AUC33X](#) [FAN53611AUC123X](#) [FAN48610BUC33X](#) [FAN48610BUC45X](#) [FAN48617UC50X](#) [R3](#) [430464BB](#) [KE177614](#)  
[MAX809TTR](#) [NCV891234MW50R2G](#) [NCP81103MNTXG](#) [NCP81203PMNTXG](#) [NCP81208MNTXG](#) [NCP81109GMNTXG](#)  
[SCY1751FCCT1G](#) [NCP81109JMNTXG](#) [AP3409ADNTR-G1](#) [LTM8064IY](#) [LT8315EFE#TRPBF](#) [NCV1077CSTBT3G](#) [XCL207A123CR-G](#)  
[MPM54304GMN-0002](#) [MPM54304GMN-0003](#) [XDPE132G5CG000XUMA1](#) [DA9121-B0V76](#) [LTC3644IY#PBF](#) [MP8757GL-P](#)  
[MIC23356YFT-TR](#) [LD8116CGL](#) [HG2269M/TR](#) [OB2269](#) [XD3526](#) [U6215A](#) [U6215B](#) [U6620S](#) [LTC3803ES6#TR](#) [LTC3803ES6#TRM](#)  
[LTC3412IFE](#) [LT1425IS](#) [MAX25203BATJA/VY+](#) [MAX77874CEWM+](#) [XC9236D08CER-G](#) [ISL95338IRTZ](#) [MP3416GJ-P](#) [BD9S201NUX-](#)  
[CE2](#) [MP5461GC-Z](#) [MPQ4415AGQB-Z](#) [MPQ4590GS-Z](#) [MCP1603-330IMC](#) [MCP1642B-18IMC](#)