



Low-Cost, 7ns, Low-Power Voltage Comparators

General Description

The MAX9201/MAX9202/MAX9203 high-speed, low-power, quad/dual/single comparators feature TTL logic outputs with active internal pullups. Fast propagation delay (7ns typ at 5mV overdrive) makes these devices ideal for fast A/D converters and sampling circuits, line receivers, V/F converters, and many other data-discrimination, signal restoration applications.

All comparators can be powered from separate analog and digital power supplies or from a single combined supply voltage. The analog input common-mode range includes the negative rail, allowing ground sensing when powered from a single supply. The MAX9201/MAX9202/MAX9203 consume only 9mW per comparator when powered from a +5V supply.

The MAX9202/MAX9203 feature output latches with TTL compatible inputs. The comparator output states are held when the latch inputs are driven low. The MAX9201 provides all the same features as the MAX9202/MAX9203 with the exception of the latches.

The MAX9201/MAX9202/MAX9203 are lower power and lower cost upgrades to the MAX901/MAX902/MAX903 offering a 50% power savings and smaller packaging.

Applications

High-Speed A/D Converters
High-Speed V/F Converters
Line Receivers
High-Speed Signal Squaring/Restoration

Threshold Detectors
Input Trigger Circuitry
High-Speed Data Sampling
PWM Circuits

Features

- ◆ Fast 7ns Propagation Delay
- ◆ Low 9mW/Comparator Power Consumption
- ◆ Separate Analog and Digital Supplies
- ◆ Flexible Analog Supply: +5V to +10V or ±5V
- ◆ Input Voltage Range Includes Negative Supply Rail
- ◆ TTL-Compatible Outputs
- ◆ TTL-Compatible Latch Inputs (MAX9202/MAX9203)
- ◆ Available in Space-Saving Packages
 - 8-Pin SOT23 (MAX9203)
 - 14-Pin TSSOP (MAX9202)
 - 16-Pin TSSOP (MAX9201)

Ordering Information

PART	TEMP RANGE	PIN-PACKAGE
MAX9201EUE	-40°C to +85°C	16 TSSOP
MAX9201ESE	-40°C to +85°C	16 Narrow SO
MAX9202EUD	-40°C to +85°C	14 TSSOP
MAX9202ESD	-40°C to +85°C	14 Narrow SO
MAX9203EKA-T	-40°C to +85°C	8 SOT23-8
MAX9203ESA	-40°C to +85°C	8 Narrow SO

Pin Configurations

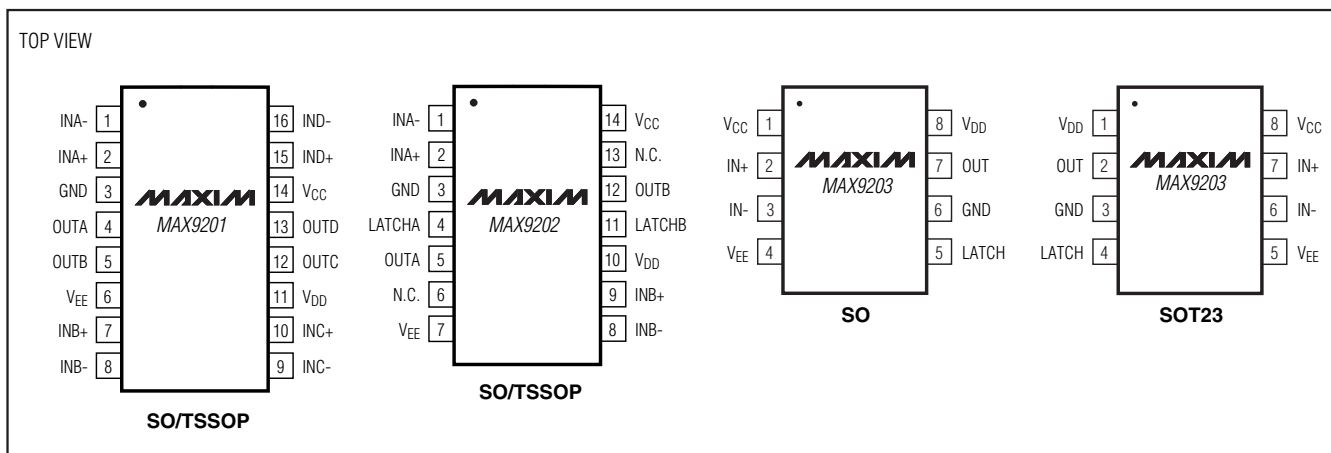

Low Cost, 7ns, Low-Power Voltage Comparators

ABSOLUTE MAXIMUM RATINGS

Analog Supply Voltage (V _{CC} - V _{EE})	+12V
Digital Supply Voltage (V _{DD})	+7V
Differential Input Voltage	(V _{EE} - 0.3V) to (V _{CC} + 0.3V)
Common Mode Input Voltage	(V _{EE} - 0.3V) to (V _{CC} + 0.3V)
Latch Input Voltage	
(MAX9202/MAX9203 only)	-0.3V to (V _{DD} + 0.3V)
Output Short-Circuit Duration	
To GND	Continuous
To V _{DD}	1min

Continuous Power Dissipation (T _A = +70°C)	
8-Pin SOT23-8 (derate 9.1mW/°C above +70°C)	...727mW/°C
8-Pin SO (derate 5.9mW/°C above +70°C)471mW/°C
14-Pin TSSOP (derate 9.1mW/°C above +70°C)727mW/°C
14-Pin SO (derate 8.3mW/°C above +70°C)667mW/°C
16-Pin TSSOP (derate 9.4mW/°C above +70°C)755mW/°C
16-Pin SO (derate 8.7mW/°C above +70°C)696mW/°C
Operating Temperature Range	-45°C to +85°C
Junction Temperature+150°C
Storage Temperature Range-65°C to +150°C
Lead Temperature (soldering, 10s)+300°C

Stresses beyond those listed under "Absolute Maximum Ratings" may cause permanent damage to the device. These are stress ratings only, and functional operation of the device at these or any other conditions beyond those indicated in the operational sections of the specifications is not implied. Exposure to absolute maximum rating conditions for extended periods may affect device reliability.

ELECTRICAL CHARACTERISTICS

(V_{CC} = +5V, V_{EE} = -5V, V_{DD} = +5V, GND = 0, V_{CM} = 0, LATCH_L = logic high, T_A = -40°C to +85°C. Typical values are at T_A = +25°C, unless otherwise noted.) (Note 1)

PARAMETER	SYMBOL	CONDITIONS		MIN	TYP	MAX	UNITS
Analog Supply Voltage Range	V _{CC} - V _{EE}	Referenced to V _{EE}		4.75		10.5	V
Digital Supply Voltage Range	V _{DD}	Referenced to GND		4.75		5.25	V
Input Offset Voltage	V _{OS}	V _{CM} = 0, V _{OUT} = 1.4V	T _A = +25°C		1	4	mV
			T _A = -40°C to +85°C			7.5	
Input Bias Current	I _B	I _{IN+} or I _{IN-}	T _A = +25°C		1.25	5	μA
			T _A = -40°C to +85°C			7.0	
Input Offset Current	I _{OS}	V _{CM} = 0, V _{OUT} = 1.4V	T _A = +25°C		50	250	nA
			T _A = -40°C to +85°C			450	
Common-Mode Input Voltage Range	V _{CM}	Note 2		V _{EE} - 0.1		V _{CC} - 2.25	V
Common-Mode Rejection Ratio	CMRR	-5.1V < V _{CM} < +2.75V V _{OUT} = 1.4V	T _A = +25°C		50	150	μV/V
			T _A = -40°C to +85°C			250	
Power-Supply Rejection Ratio	PSRR	Note 3	T _A = +25°C		50	150	μV/V
			T _A = -40°C to +85°C			250	
Output High Voltage	V _{OH}	(V _{IN+} - V _{IN-}) > 250mV, I _{SOURCE} = 1mA		3.0	3.5		V
Output Low Voltage	V _{OL}	(V _{IN+} - V _{IN-}) < -250mV, I _{SINK} = 8mA			0.25	0.4	V
Latch Input Threshold Voltage High	V _{LH}	Note 4			1.4	2	V
Latch Input Threshold Voltage Low	V _{LL}	Note 4		0.8	1.4		V
Latch Input Current High	I _{LH}	V _{LH} = 3.0V, Note 4			0.5	3	μA
Latch Input Current Low	I _{LL}	V _{LL} = 0.3V, Note 4			0.5	3	μA
Input Capacitance	C _{IN}				4		pF
Differential Input Impedance	R _{IND}				5		MΩ
Common-Mode Input Impedance	R _{INCM}				5.5		MΩ
Positive Analog Supply Current	I _{CC}	Note 5	MAX9201		4.7	7	mA
			MAX9202		2.5	4.0	
			MAX9203		1.3	2	

Low Cost, 7ns, Low-Power Voltage Comparators

MAX9201/MAX9202/MAX9203

ELECTRICAL CHARACTERISTICS (continued)

($V_{CC} = +5V$, $V_{EE} = -5V$, $V_{DD} = +5V$, $GND = 0$, $V_{CM} = 0$, $LATCH_ =$ logic high, $T_A = -40^{\circ}C$ to $+85^{\circ}C$. Typical values are at $T_A = +25^{\circ}C$, unless otherwise noted.) (Note 1)

PARAMETER	SYMBOL	CONDITIONS		MIN	TYP	MAX	UNITS
Negative Analog Supply Current	I _{EE}	Note 5	MAX9201		3.4	5.0	mA
			MAX9202		1.8	3.0	
			MAX9203		1.0	1.6	
Digital Supply Current	I _{DD}	Note 5	MAX9201		2	3.0	mA
			MAX9202		1	1.5	
			MAX9203		0.5	0.8	
Power Dissipation	P _D	V _{CC} = V _{DD} = +5V, V _{EE} = 0V	MAX9201		33	44	mW
			MAX9202		17	24	
			MAX9203		9	13	

TIMING CHARACTERISTICS

($V_{CC} = +5V$, $V_{EE} = -5V$, $V_{DD} = +5V$, $GND = 0$, $V_{CM} = 0$, $LATCH_ =$ logic high, $T_A = -40^{\circ}C$ to $+85^{\circ}C$. Typical values are at $T_A = +25^{\circ}C$, unless otherwise noted.) (Notes 1, 6)

PARAMETER	SYMBOL	CONDITIONS		MIN	TYP	MAX	UNITS
Input-to-Output High Response Time	t _{PD+}	V _{OD} = 5mV, C _L = 15pF, I _{OUT} = 2mA	T _A = +25°C		7	9	ns
			T _A = -40°C to +85°C			12	
Input-to-Output Low Response Time	t _{PD-}	V _{OD} = 5mV, C _L = 15pF, I _{OUT} = 2mA	T _A = +25°C		7	9	ns
			T _A = -40°C to +85°C			12	
Rise Time	t _R	C _L = 15pF, I _{OUT} = 2mA	T _A = +25°C		2.0		ns
Fall Time	t _F	C _L = 15pF, I _{OUT} = 2mA	T _A = +25°C		1.0		ns
Difference in Response Time Between Outputs	Δt _{PD}	Note 7	T _A = +25°C		0.5	1.5	ns
			T _A = -40°C to +85°C			2.5	
Latch Disable to Output High Delay	t _{PD+(D)}	Note 4			10		ns
Latch Disable to Output Low Delay	t _{PD-(D)}	Note 4			10		ns
Minimum Setup Time	t _S	Note 4			2		ns
Minimum Hold Time	t _N	Note 4			1		ns
Minimum Latch Disable Pulse Width	t _{PW(D)}	Note 4			8		ns

Note 1: All devices are 100% production tested at $T_A = +25^{\circ}C$. All temperature limits are guaranteed by design.

Note 2: Inferred by CMRR test.

Note 3: Tested for $+4.75V < V_{CC} < +5.25V$, and $-5.25V < V_{EE} < -4.75V$ with $V_{DD} = +5V$, although permissible analog power-supply range is $4.75V < V_{CC} < +10.5V$ for single supply operation with V_{EE} grounded.

Note 4: Specification does not apply to MAX9201.

Note 5: I_{CC} tested for $4.75V < V_{CC} < +10.5V$ with V_{EE} grounded. I_{EE} tested for $-5.25V < V_{EE} < -4.75V$ with $V_{CC} = +5V$. I_{DD} tested for $+4.75V < V_{DD} < +5.25V$ with all comparator outputs low, worst-case condition.

Note 6: Guaranteed by design. Times are for 100mV step inputs (see propagation delay characteristics in Figures 2 and 3)

Note 7: Maximum difference in propagation delay between two comparators in the MAX9201/MAX9202.

Low Cost, 7ns, Low-Power Voltage Comparators

Typical Operating Characteristics

($V_{CC} = +5V$, $V_{EE} = -5V$, $V_{DD} = +5V$, $GND = 0$, $V_{CM} = 0$, $LATCH_{-} = \text{logic high}$, $V_{OUT} = 1.4V$, $T_A = +25^{\circ}C$, unless otherwise noted.)

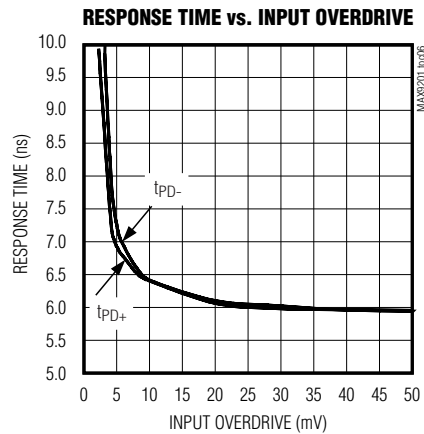
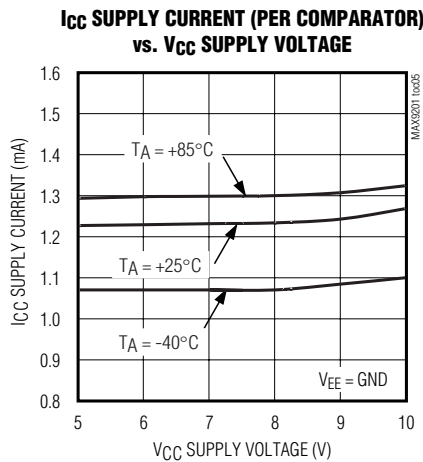
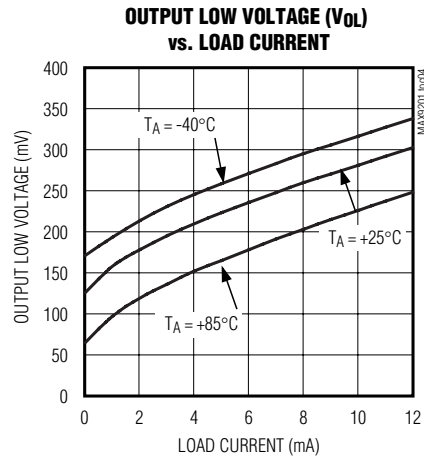
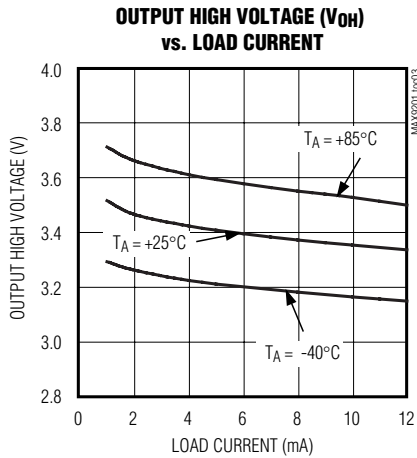
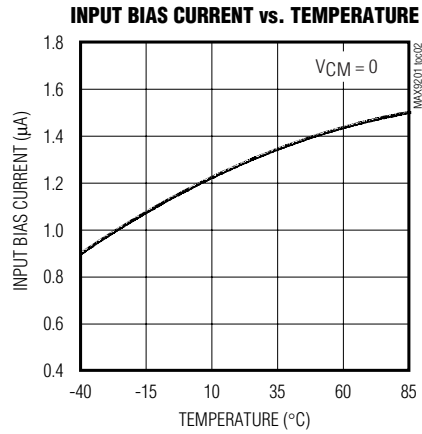
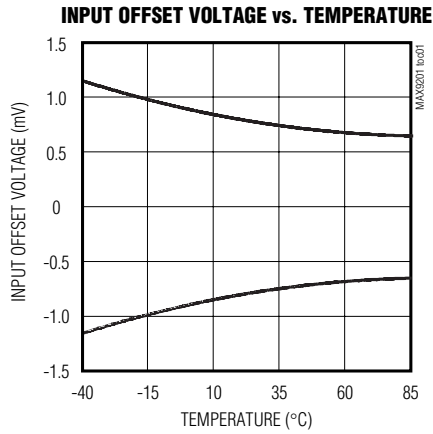

Low Cost, 7ns, Low-Power Voltage Comparators

Typical Operating Characteristics (continued)

($V_{CC} = +5V$, $V_{EE} = -5V$, $V_{DD} = +5V$, $GND = 0$, $V_{CM} = 0$, $LATCH_ = \text{logic high}$, $V_{OUT} = 1.4V$, $T_A = +25^\circ C$, unless otherwise noted.)

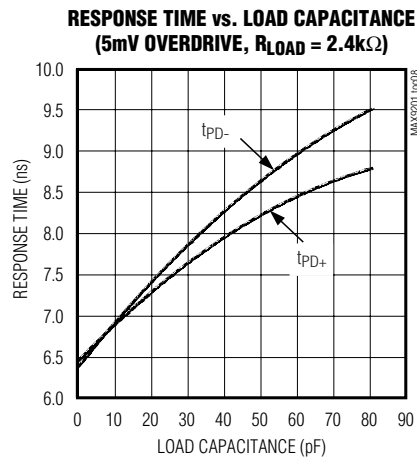
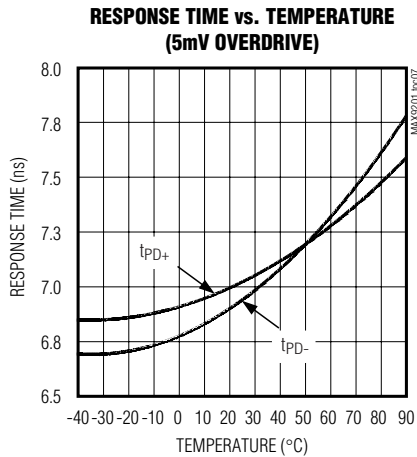

Pin Description

MAX9201

PIN	NAME	FUNCTION
1, 8, 9, 16	IN ₋	Negative Input (Channels A, B, C, D)
2, 7, 10, 15	IN ₊	Positive Input (Channels A, B, C, D)
3	GND	Ground
4, 5, 12, 13	OUT ₋	Output (Channels A, B, C, D)
6	V _{EE}	Negative Analog Supply and Substrate
11	V _{DD}	Positive Digital Supply
14	V _{CC}	Positive Analog Supply

MAX9202

PIN	NAME	FUNCTION
1, 8	IN ₋	Negative Input (Channels A, B)
2, 9	IN ₊	Positive Input (Channels A, B)
3	GND	Ground
4, 11	LATCH ₋	Latch Input (Channels A, B)
5, 12	OUT ₋	Output (Channels A, B)
6, 13	N.C.	No Connection
7	V _{EE}	Negative Analog Supply and Substrate
10	V _{DD}	Positive Digital Supply
14	V _{CC}	Positive Analog Supply

MAX9201/MAX9202/MAX9203

Low Cost, 7ns, Low-Power Voltage Comparators

Pin Description (continued)

MAX9203

PIN		NAME	FUNCTION
SO	SOT		
1	8	V _{CC}	Positive Analog Supply
2	7	IN+	Positive Input
3	6	IN-	Negative Input
4	5	V _{EE}	Negative Analog Supply and Substrate
5	4	LATCH	Latch Input
6	3	GND	Ground
7	2	OUT	Output
8	1	V _{DD}	Positive Digital Supply

Applications Information

Circuit Layout

Because of the large gain-bandwidth transfer function of the MAX9201/MAX9202/MAX9203 special precautions must be taken to realize their full high-speed capability. A printed circuit board with a good, low-inductance ground plane is mandatory. All decoupling capacitors (the small 100nF ceramic type is a good choice) should be mounted as close as possible to the power-supply pins. Separate decoupling capacitors for analog V_{CC} and for digital V_{DD} are also recommended. Close attention should be paid to the bandwidth of the

decoupling and terminating components. Short lead lengths on the inputs and outputs are essential to avoid unwanted parasitic feedback around the comparators. Solder the device directly to the printed circuit board instead of using a socket.

Input Slew-Rate Requirements

As with all high-speed comparators, the high gain-bandwidth product of the MAX9201/MAX9202/ MAX9203 can create oscillation problems when the input traverses the linear region. For clean output switching without oscillation or steps in the output waveform, the input must meet minimum slew-rate requirements (0.5V/s typ). Oscillation is largely a function of board layout and of coupled source impedance and stray input capacitance. Both poor layout and large source impedance will cause the part to oscillate and increase the minimum slew-rate requirement. In some applications, it may be helpful to apply some positive feedback between the output and positive input. This pushes the output through the transition region clearly, but applies a hysteresis in threshold seen at the input terminals.

TTL Output and Latch Inputs

The comparator TTL output stages are optimized for driving low-power Schottky TTL with a fan-out of four.

When the latch is connected to a logic high level, the comparator is transparent and immediately responds to changes at the input terminals. When the latch is connected to a TTL low level, the comparator output latches (in the same state) the instant that the latch command is applied, and will not respond to subsequent changes at the input. No latch is provided on the MAX9201.

Typical Power-Supply Alternatives

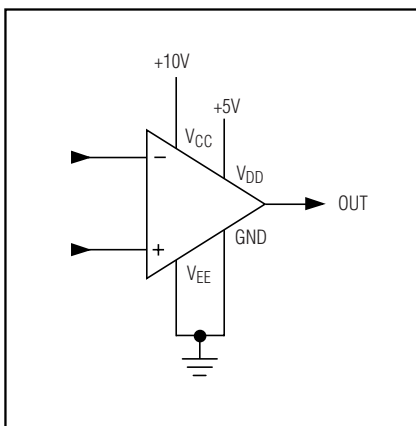

Figure 1a. Separate Analog Supply, Common Ground

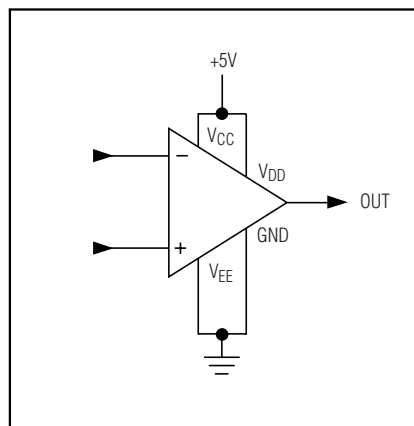

Figure 1b. Single +5V Supply, Common Ground

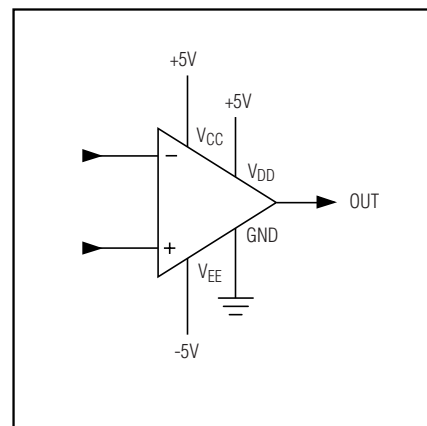

Figure 1c. Split ±5V Supply, Separate Ground

Low Cost, 7ns, Low-Power Voltage Comparators

MAX9201/9202/9203

Power Supplies

The MAX9201/MAX9202/MAX9203 can be powered from separate analog and digital supplies or from a single +5V supply. The analog supply can range from +5V to +10V with V_{EE} grounded for single-supply operation (Figures 1a and 1b) or from a split $\pm 5V$ supply (Figure 1c). The V_{DD} digital supply always requires +5V.

In high-speed, mixed-signal applications where a common ground is shared, a noisy digital environment can adversely affect the analog input signal. When set up with separate supplies, the MAX9201/MAX9202/MAX9203 isolate analog and digital signals by providing a separate analog ground (V_{EE}) and digital ground (GND).

Definition of Terms

- V_{OS} Input Offset Voltage:** Voltage applied between the two input terminals to obtain TTL logic threshold (+1.4V) at the output.
- V_{IN} Input Voltage Pulse Amplitude:** Usually set to 100mV for comparator specifications.
- V_{OD} Input Voltage Overdrive:** Usually set to 5mV and in opposite polarity to V_{IN} for comparator specifications.
- t_{pd+} Input to Output High Delay:** The propagation delay measured from the time the input signal crosses the input offset voltage to the TTL logic threshold (+1.4V) of an output low to high transition.

- t_{pd-} Input to Output Low Delay:** The propagation delay measured from the time the input signal crosses the input offset voltage to the TTL logic threshold (+1.4V) of an output high to low transition.
- $t_{pd+} (D)$ Latch Disable to Output High Delay:** The propagation delay measured from the latch signal crossing the TTL logic threshold (+1.4V) in a low to high transition to the point of the output crossing TTL threshold (+1.4V) in a low to high transition.
- $t_{pd-} (D)$ Latch Disable to Output Low Delay:** The propagation delay measured from the latch signal crossing the TTL threshold (+1.4V) in a low to high transition to the point of the output crossing TTL threshold (+1.4V) in a high to low transition.
- t_s Minimum Setup Time:** The minimum time, before the negative transition of the latch signal, that an input signal change must be present in order to be acquired and held at the outputs.
- t_h Minimum Hold Time:** The minimum time, after the negative transition of the latch signal, that an input signal must remain unchanged in order to be acquired and held at the output.
- $t_{pw} (D)$ Minimum Latch Disable Pulse Width:** The minimum time that the latch signal must remain high in order to acquire and hold an input signal change.

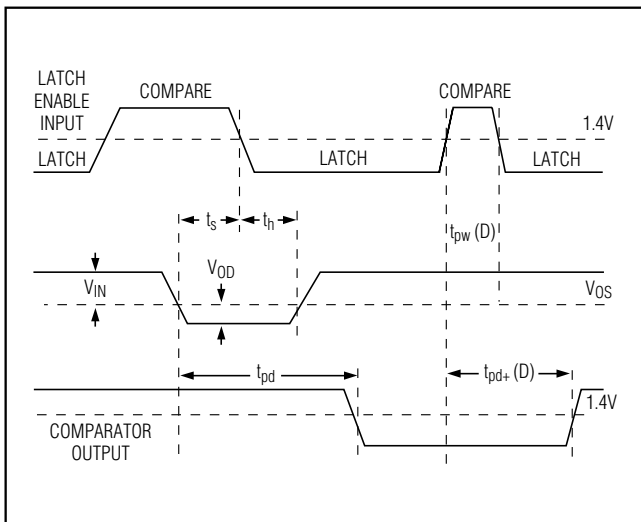

Figure 2. MAX9201/MAX9202/MAX9203 Diagram

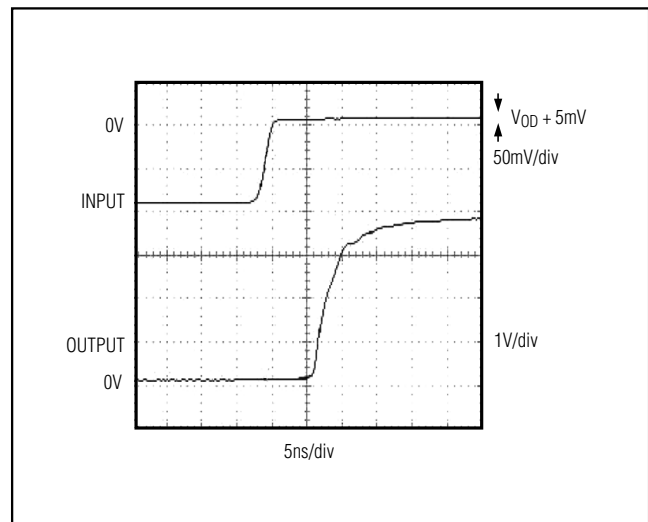

Figure 3. t_{pd+} Response Time to 5mV Overdrive

Low Cost, 7ns, Low-Power Voltage Comparators

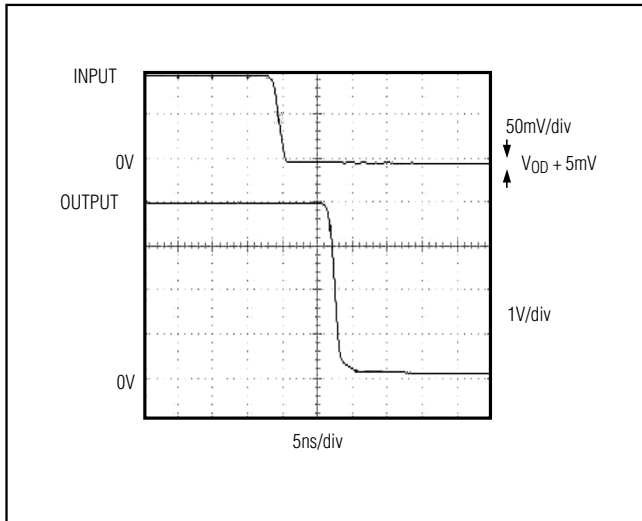

Figure 4. t_{PD} . Response Time to 5mV Overdrive

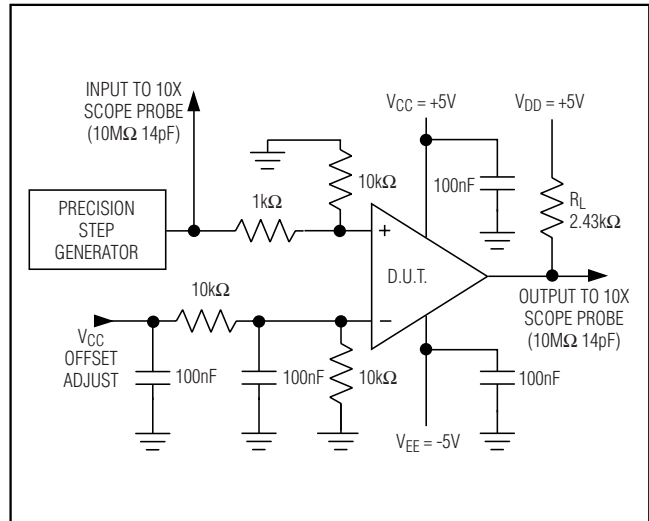

Figure 5. Response-Time Setup

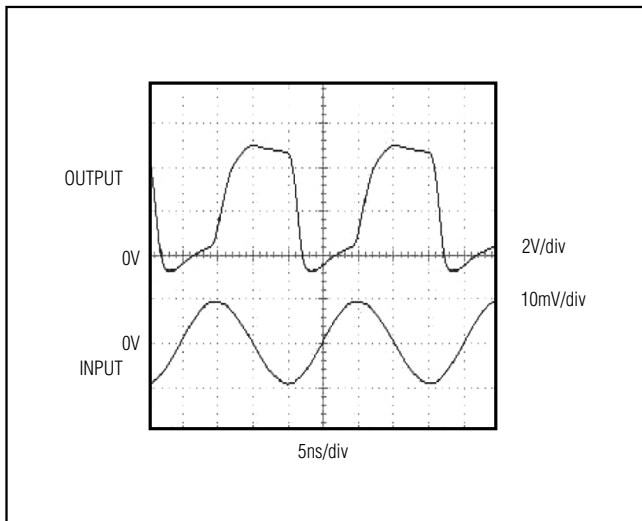

Figure 6. Response to 50MHz Sine Wave

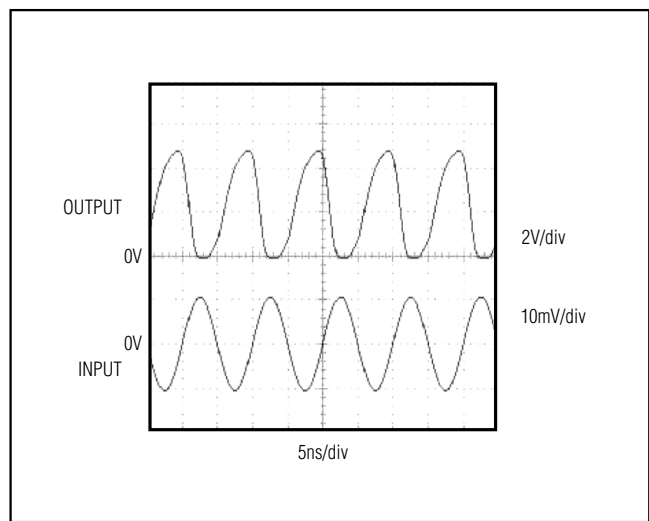

Figure 7. Response to 100MHz Sine Wave

Chip Information

MAX9201 TRANSISTOR COUNT: 348

MAX9202 TRANSISTOR COUNT: 176

MAX9203 TRANSISTOR COUNT: 116

PROCESS: Bipolar

Maxim cannot assume responsibility for use of any circuitry other than circuitry entirely embodied in a Maxim product. No circuit patent licenses are implied. Maxim reserves the right to change the circuitry and specifications without notice at any time.

8 **Maxim Integrated Products, 120 San Gabriel Drive, Sunnyvale, CA 94086 408-737-7600**

X-ON Electronics

Largest Supplier of Electrical and Electronic Components

Click to view similar products for [Analog Comparators](#) category:

Click to view products by [Maxim](#) manufacturer:

Other Similar products are found below :

[633740E](#) [NCV2200SN2T1G](#) [NCV2200SQ2T2G](#) [SC339DR2G](#) [LM2901SNG](#) [LM339SNG](#) [418524AB](#) [TS393CD C3](#) [LM393SNG](#) [55122](#)
[5962-8757203IA](#) [MAX971ESA+T](#) [MAX961ESAT](#) [MAX944ESD+T](#) [MAX984CPE](#) [MAX9062EBSTG45](#) [RT2902YDT](#) [NTE911](#) [5962-](#)
[8751601DA](#) [5962-8751601CA](#) [MAX961EUA+T](#) [MAX9065EBS+TG45](#) [NJM2903RB1-TE1](#) [NCV2202SN2T1G](#) [MAX919ESA+T](#)
[MAX19005CCS+](#) [LM339EDR2G](#) [NTE919](#) [NTE922](#) [TS883IQ2T](#) [LT6700HVCS6-3#TRMPBF](#) [LT6700HVHS6-3#TRMPBF](#)
[MAX978EEE+T](#) [MAX975ESA+T](#) [MAX9602EUG+T](#) [MAX997EUA+T](#) [MIC841NYC5-T5](#) [LM393WDT](#) [MCP6564T-E/STVAO](#)
[MAX983ESA+T](#) [NCX2200GMAZ](#) [MC10E1651FNG](#) [MCP6544-EP](#) [MCP6541UT-I/LT](#) [MCP6542T-E/MS](#) [MCP6542T-I/SN](#) [MCP6547T-](#)
[EMS](#) [MCP6549-E/P](#) [MCP6562T-E/MS](#) [MCP6567-E/MS](#)