

Dual, 2-Wire Hall-Effect Sensor Interface with Diagnostics

General Description

The MAX9921 provides a single chip solution to interface two 2-wire Hall-effect sensors to a low-voltage micro-processor (μ P). This device supplies and monitors the current drawn by two Hall-effect sensors, filters the sensed current level, and outputs the corresponding logic level.

The MAX9921 includes input diagnostics and fault protection. These features allow the device to determine fault conditions such as open inputs, inputs shorted to the battery, and inputs shorted to ground. If the MAX9921 detects any of these conditions at either IN1 or IN2, the device shuts off the current to the corresponding input.

The MAX9921 protects the Hall sensors from supply transients up to 60V at the BAT supply. Normal operating supply voltage ranges from 6V to 18V. If the battery voltage is out of range, the MAX9921 shuts off the current to the Hall sensors.

The MAX9921 provides an 80 μ s blanking time following Hall sensor power-up or restart. The open-drain logic outputs are compatible with logic levels up to 5.5V.

The MAX9921 is available in a small 10-pin μ MAX[®] package and is specified over the -40°C to +125°C automotive temperature range.

Applications

| | |
|-------------------|------------------------|
| Door Modules | Powered Lift Gate |
| Window Lifters | Controllers |
| Seat Movers | Powered Running Boards |
| Electric Sunroofs | Seatbelt Buckles |

Features

- ◆ Withstands 60V at BAT Supply and Hall Inputs
- ◆ 6V to 18V Operating Voltage Range
- ◆ Provides Supply Current and Interfaces to Two 2-Wire Hall Sensors
- ◆ Error Output with Diagnostics of Hall Inputs and BAT Voltage
- ◆ Protects Hall Sensors from Overvoltage by Isolating Them from Supply Transients
- ◆ Hall Inputs Protected from Short to Ground
- ◆ Ramps Current to Hall Sensors at 4mA/ μ s
- ◆ Output Enable Input Allows Multiplexing of Outputs from Multiple MAX9921s
- ◆ Hall Output Filtering
- ◆ Hall Sensor Blanking Following Hall Sensor Power-Up or Restart
- ◆ Low-Power Shutdown, Controlled with OE and DIAG Inputs
- ◆ Operates with \pm 2V Ground Shifts Between Hall Sensor and MAX9921

Ordering Information

| PART | TEMP RANGE | PIN-PACKAGE |
|----------------|-----------------|--------------|
| MAX9921AUB+T | -40°C to +125°C | 10 μ MAX |
| MAX9921AUB/V+T | -40°C to +125°C | 10 μ MAX |

+ Denotes a lead(Pb)-free/RoHS-compliant package.

T = Tape and reel.

V denotes an automotive qualified part.

Pin Configuration appears at end of data sheet.

Typical Application Circuit

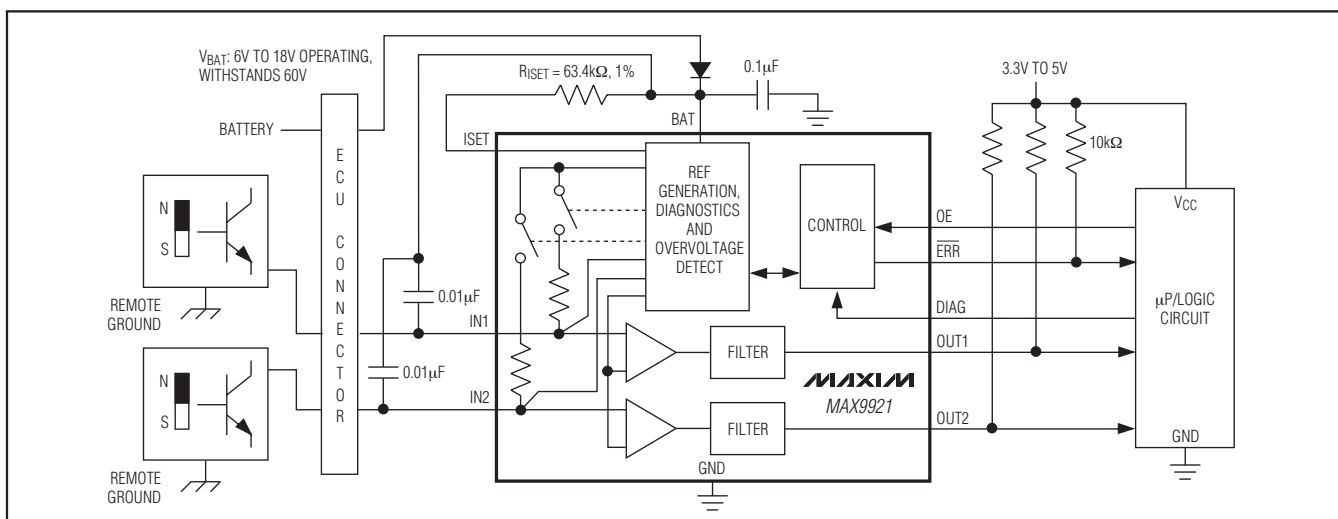

μ MAX is a registered trademark of Maxim Integrated Products, Inc.

Dual, 2-Wire Hall-Effect Sensor Interface with Diagnostics

ABSOLUTE MAXIMUM RATINGS

| | | | |
|--|---|---|-----------------|
| BAT to GND | -0.3V to +60V | Current into IN1, IN2 | ±100mA |
| ISET to BAT | -2.0V to +0.3V | Continuous Power Dissipation (T _A = +70°C) | |
| IN1, IN2 to GND | -5.0V to the lower of +60V or (V _{BAT} + 1V) | 10-Pin μMAX (derate 5.6mW/°C above +70°C) | 444.4mW |
| DIAG, OE to GND | -0.3V to +6.0V | Operating Temperature Range | -40°C to +125°C |
| OUT1, OUT2, ERR to GND | -0.3V to +6.0V | Junction Temperature | +150°C |
| Short-Circuit Duration of OUT1, OUT2, ERR to GND | or to 5.5V (individually) | Storage Temperature Range | -65°C to +150°C |
| Current into Any Pin Except IN1, IN2 | Continuous ±20mA | Lead Temperature (soldering, 10s) | +300°C |

Stresses beyond those listed under "Absolute Maximum Ratings" may cause permanent damage to the device. These are stress ratings only, and functional operation of the device at these or any other conditions beyond those indicated in the operational sections of the specifications is not implied. Exposure to absolute maximum rating conditions for extended periods may affect device reliability.

DC ELECTRICAL CHARACTERISTICS

(V_{BAT} = 13.6V, V_{DIAG} = 0, V_{OE} = 5V, IN1 = IN2 = no connection, R_{ISET} = 63.4kΩ, R_{PU} = 10kΩ at ERR, OUT1 and OUT2, T_A = -40°C to +125°C, unless otherwise noted. Typical values are at T_A = +25°C.) (Note 1)

| PARAMETER | SYMBOL | CONDITIONS | MIN | TYP | MAX | UNITS |
|---|---------------------|---|----------------------------|------|-------|-------|
| GENERAL | | | | | | |
| BAT Supply Range | V _{BAT} | | 6 | | 18 | V |
| V _{BAT} Low for ERR Output Active | V _{BL} | | 5.2 | | | V |
| V _{BAT} High for ERR Output Active | V _{BH} | | | | 22 | V |
| BAT Supply Current | I _{BAT} | Normal mode | | 1 | 1.3 | mA |
| | I _{SD} | Shutdown mode, V _{OE} = V _{DIAG} = 0V | | | 1 | μA |
| HALL INPUTS (IN1 and IN2) | | | | | | |
| Input Current for Output High | I _{IH} | R _{ISET} = 63.4kΩ | | | -11.5 | mA |
| | | R _{ISET} = 59.0kΩ | | | -12.4 | |
| Input Current for Output Low | I _{IL} | R _{ISET} = 63.4kΩ | -7.2 | | | mA |
| | | R _{ISET} = 59.0kΩ | -7.8 | | | |
| Input Current Hysteresis for High/Low Detection | I _{IN,HYS} | R _{ISET} = 63.4kΩ | | 0.76 | | mA |
| | | R _{ISET} = 59.0kΩ | | 0.78 | | |
| Input Pullup Impedance | R _{PU} | V _{BAT} = 6V, inputs IN1, IN2 with I _{IN} = -14mA | | 50 | | Ω |
| Input Voltage Interpreted as Shorted to Battery | V _{SB} | Measured with respect to V _{BAT} | | | 100 | mV |
| Current Range Interpreted as Open Circuit | I _{OC} | | -2 | | +0.02 | mA |
| Current Level Interpreted as Shorted Sensor to Ground | I _{SC} | Not a sustained condition, reverts to -50μA when detected | R _{ISET} = 63.4kΩ | | -23 | mA |
| | | | R _{ISET} = 59.0kΩ | | -25 | |

Dual, 2-Wire Hall-Effect Sensor Interface with Diagnostics

MAX9921

DC ELECTRICAL CHARACTERISTICS (continued)

(V_{BAT} = 13.6V, V_{DIAG} = 0, V_{OE} = 5V, IN1 = IN2 = no connection, R_{ISET} = 63.4kΩ, R_{PU} = 10kΩ at $\overline{\text{ERR}}$, OUT1 and OUT2, T_A = -40°C to +125°C, unless otherwise noted. Typical values are at T_A = +25°C.) (Note 1)

| PARAMETER | SYMBOL | CONDITIONS | MIN | TYP | MAX | UNITS |
|---|-----------------|--|-----|-----|-----|-------|
| LOGIC I/O (OUT1, OUT2, $\overline{\text{ERR}}$, DIAG, and OE) | | | | | | |
| Output Voltage Low ($\overline{\text{ERR}}$, OUT1, OUT2) | V _{OL} | Sink current = 1mA | | | 0.4 | V |
| Three-State Output Current ($\overline{\text{ERR}}$, OUT1, OUT2) | I _{OZ} | V _{OE} = 0V, 0 ≤ V _{OUT_} ≤ 5V | | | ±1 | μA |
| Input-Voltage High (DIAG, OE) | V _{IH} | | 2.1 | | | V |
| Input-Voltage Low (DIAG, OE) | V _{IL} | | | | 0.8 | V |
| Input Resistance to GND (DIAG, OE) | R _{IN} | | 50 | 80 | | kΩ |

AC TIMING CHARACTERISTICS

(V_{BAT} = 13.6V, V_{DIAG} = 0, V_{OE} = 5V, IN1 = IN2 = no connection, R_{ISET} = 63.4kΩ, R_{PU} = 10kΩ at $\overline{\text{ERR}}$, OUT1 and OUT2, T_A = -40°C to +125°C, unless otherwise noted. Typical values are at T_A = +25°C.) (Notes 1, 2, and 4)

| PARAMETER | SYMBOL | CONDITIONS | MIN | TYP | MAX | UNITS |
|---|-------------------|---|-----|-----|-----|-------|
| IN1, IN2 Blanking Time at Hall Switch Power-Up | t _{BL} | I _{IH} = -11.5mA to GND, time from V _{IN_} = 500mV until OUT_ high, C _L = 20pF (Note 3) | 50 | | 140 | μs |
| IN1, IN2 Current Ramp Rate After Turn-On | t _{RAMP} | V _{IN} = GND | | 3.8 | | mA/μs |
| Delay from IN_ to OUT_ (Filter Delay) | t _{DEL} | From I _{IH} to I _{IL} or from I _{IL} to I _{IH} , C _L = 20pF, Figure 1 | | 6.5 | | μs |
| Delay from IN_ Fault to $\overline{\text{ERR}}$ | t _{ERR} | From I _{IL} to I _{SC} or from I _{IH} to I _{OC} , falling edge only, C _L = 20pF, Figure 1 | | 31 | | ns |
| Delay from DIAG High to OUT_ and $\overline{\text{ERR}}$ | t _{DLH} | Rising edge of DIAG to falling or rising edge of outputs, C _L = 20pF, Figure 1 | | 350 | | ns |
| Delay from DIAG Low to OUT_ and $\overline{\text{ERR}}$ | t _{DHL} | Falling edge of DIAG to falling or rising edge of outputs, C _L = 20pF, Figure 1 | | 1.6 | | μs |
| Delay Difference Between Rising and Falling Edges for Both Channels | t _{DM} | CHALL-BYPASS = 0.01μF, I _{IH} = -11.5mA and I _{IL} = -7.2mA, C _L = 20pF | | 20 | | ns |
| Delay Difference Between Channels | t _{CC} | CHALL-BYPASS = 0.01μF, I _{IH} = -11.5mA and I _{IL} = -7.2mA, C _L = 20pF | | 100 | | ns |
| Maximum Frequency on Hall Inputs | f _{MAX} | CHALL-BYPASS = 0.01μF, I _{IH} = -11.5mA and I _{IL} = -7.2mA, C _L = 20pF | 50 | | | kHz |
| IN_ Pulse Length Rejected by Filter to OUT_ | P _R | Figure 2 | | 5.5 | | μs |

Note 1: All DC specifications are 100% tested at T_A = +25°C. AC specifications and specifications over -40°C to +125°C are guaranteed by design.

Note 2: C_L is external load capacitance on the outputs for test only.

Note 3: These blanking times apply when the MAX9921 is operating in normal mode. Blanking times following power-up or startup from shutdown mode are 20μs longer.

Note 4: The following AC parameters change with the value of R_{ISET}: t_{BL}, t_{RAMP}, t_{DEL}, f_{MAX}, and P_R. The typ values given are for R_{ISET} = 63.4kΩ. The parameters t_{RAMP} and f_{MAX} increase 8%, and t_{DEL} and P_R decrease 8% with R_{ISET} = 59.0kΩ. The limits for t_{BL} and f_{MAX} apply for both resistor values.

Dual, 2-Wire Hall-Effect Sensor Interface with Diagnostics

Timing Diagrams

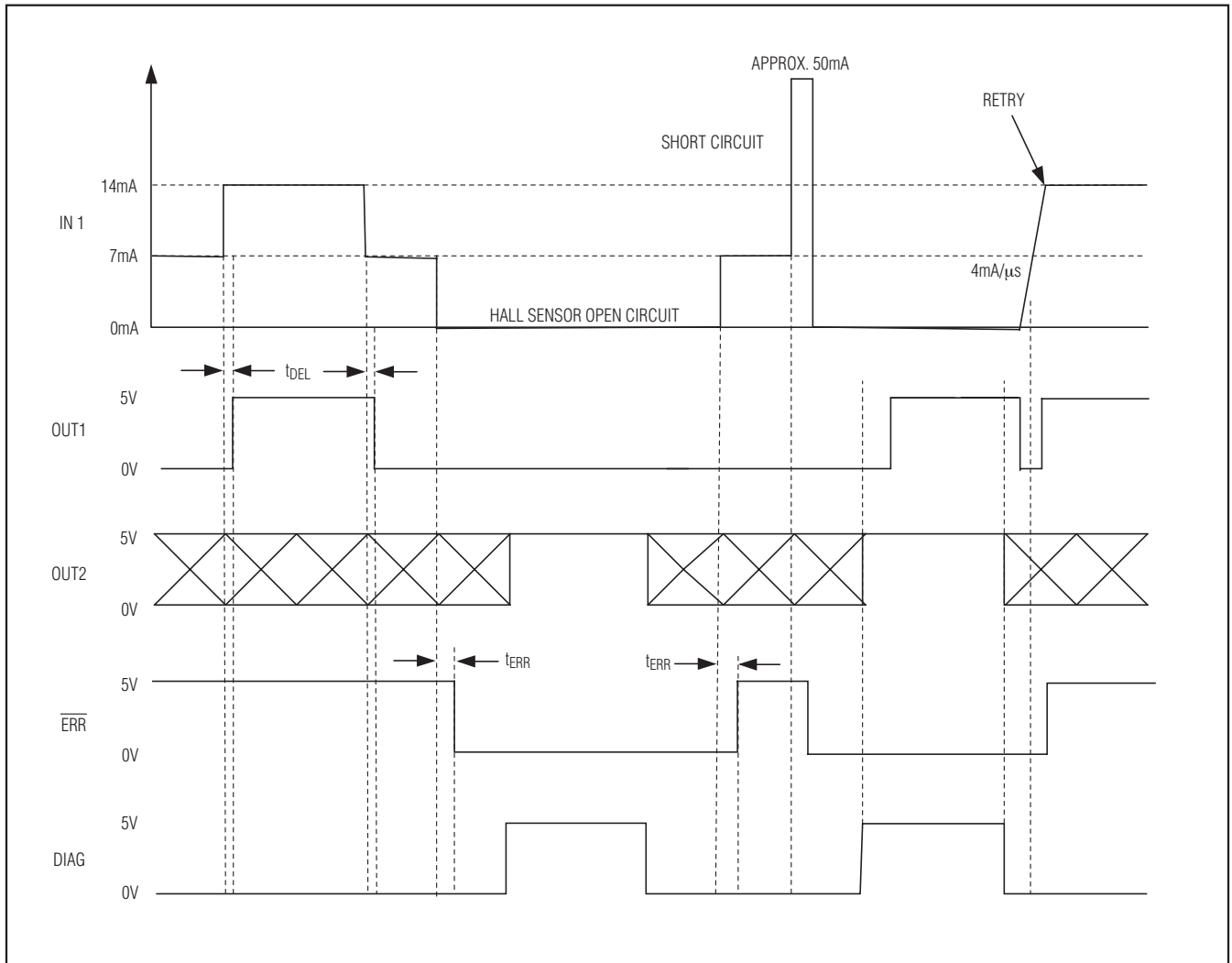

Figure 1. Timing Diagram

Dual, 2-Wire Hall-Effect Sensor Interface with Diagnostics

Timing Diagrams (continued)

MAX9921

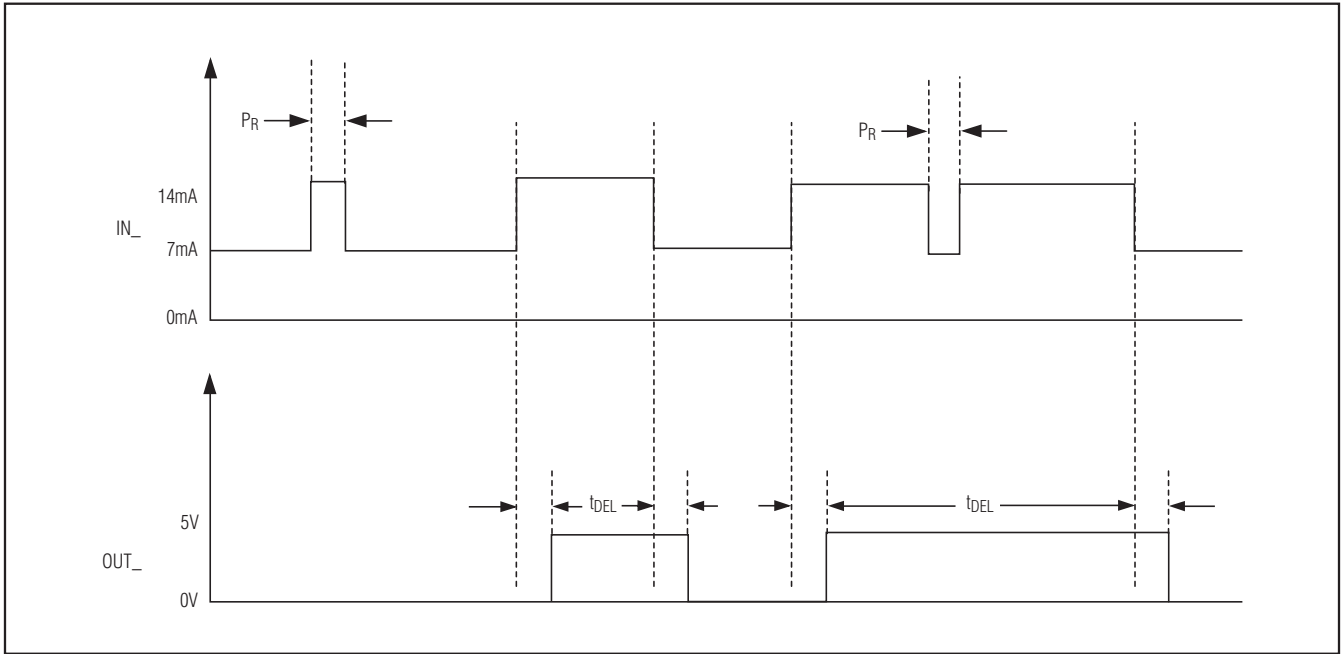
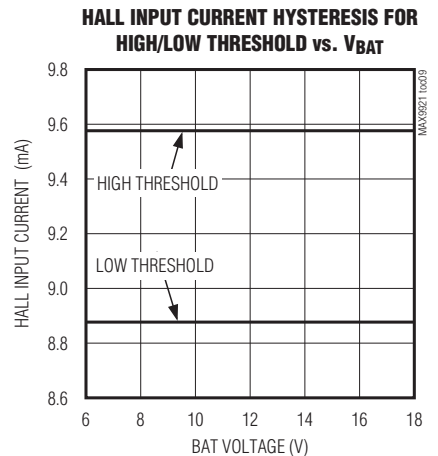
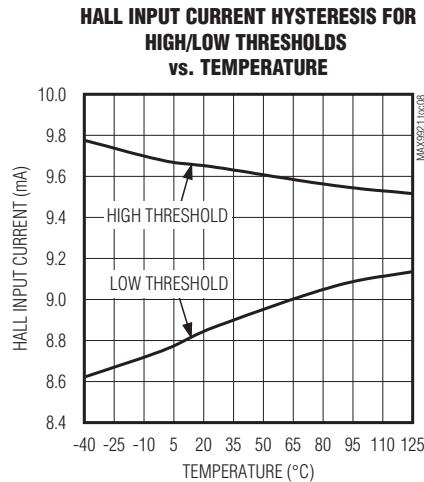
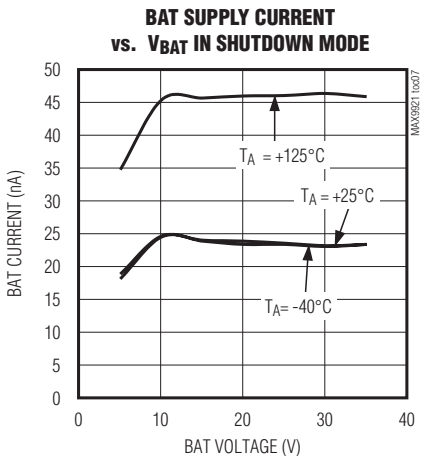
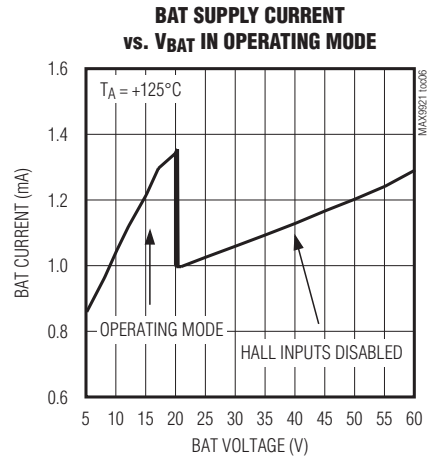
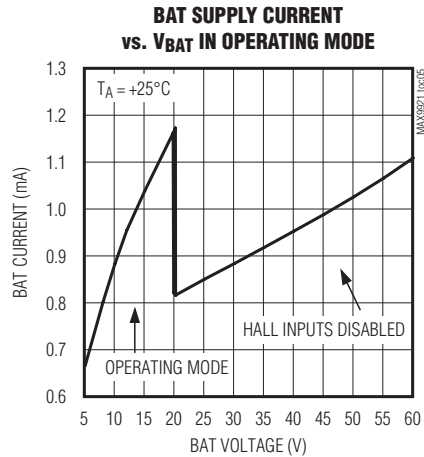
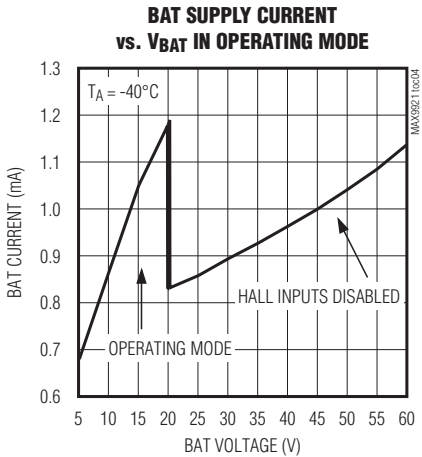
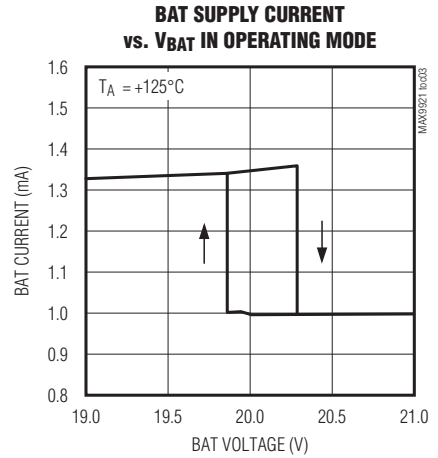
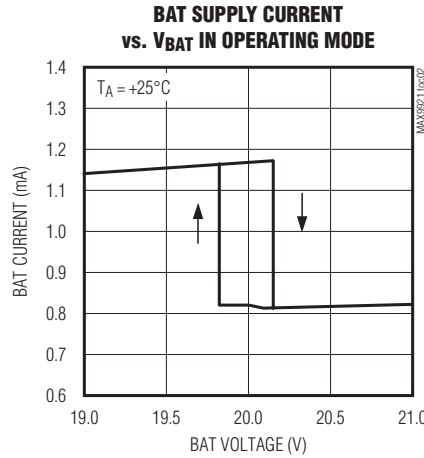
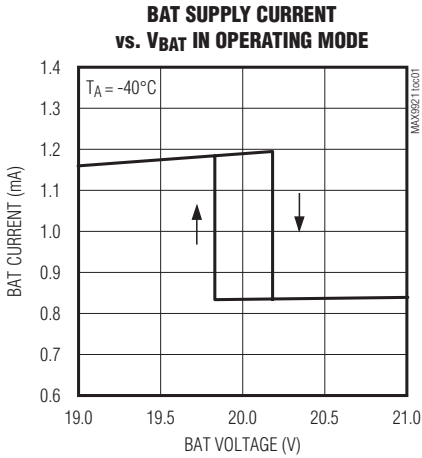

Figure 2. Hall Input Pulse Rejection

Dual, 2-Wire Hall-Effect Sensor Interface with Diagnostics

Typical Operating Characteristics

($V_{BAT} = 14V$, $T_A = +25^\circ C$, unless otherwise noted.)



Dual, 2-Wire Hall-Effect Sensor Interface with Diagnostics

MAX9921

Typical Operating Characteristics (continued)

($V_{BAT} = 14V$, $T_A = +25^\circ C$, unless otherwise noted.)

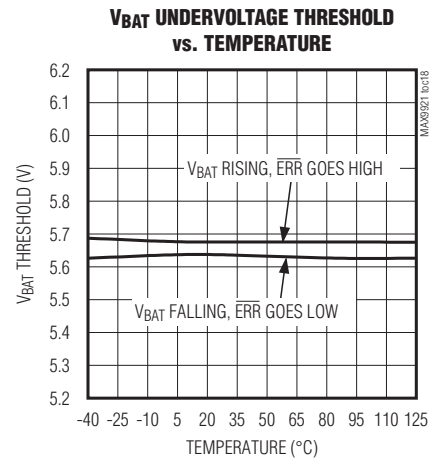
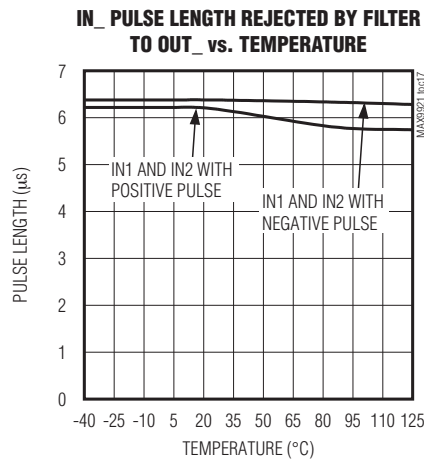
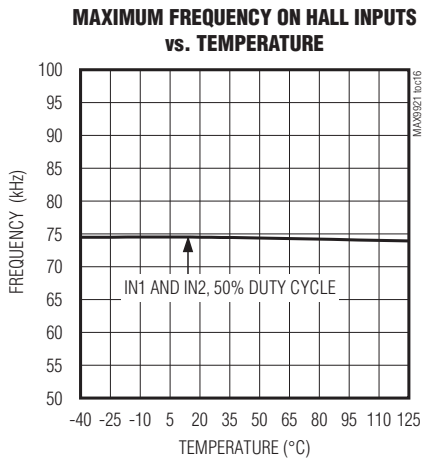
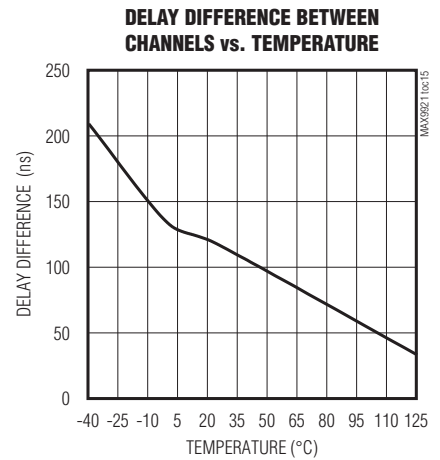
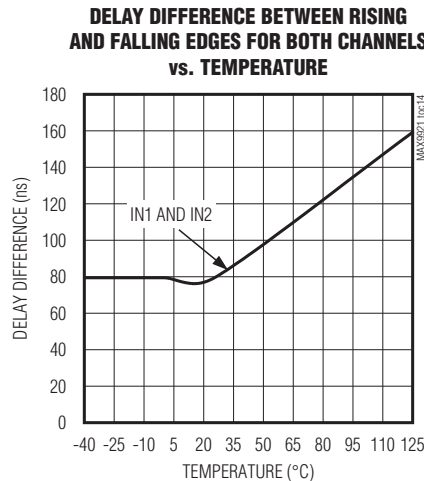
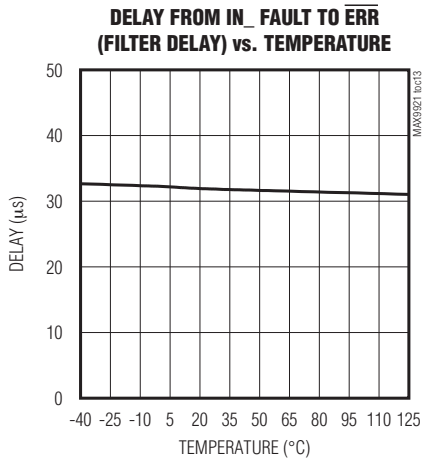
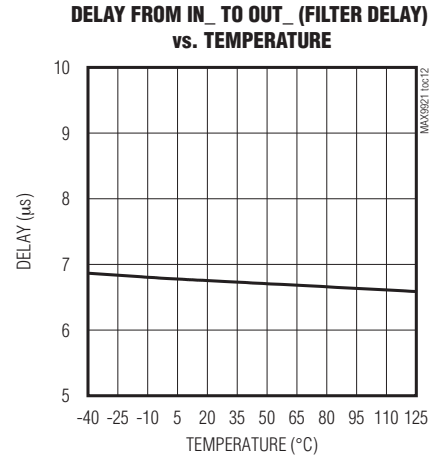
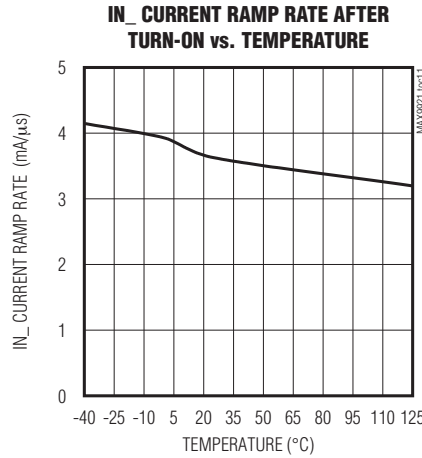
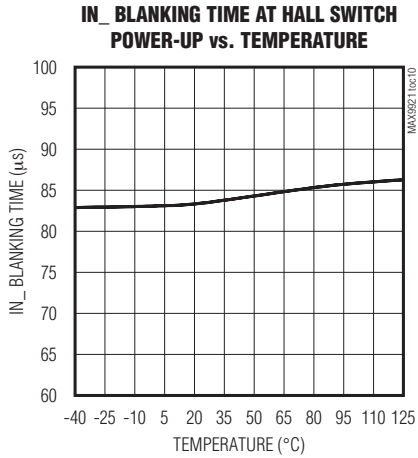

Dual, 2-Wire Hall-Effect Sensor Interface with Diagnostics

Typical Operating Characteristics (continued)

($V_{BAT} = 14V$, $T_A = +25^\circ C$, unless otherwise noted.)

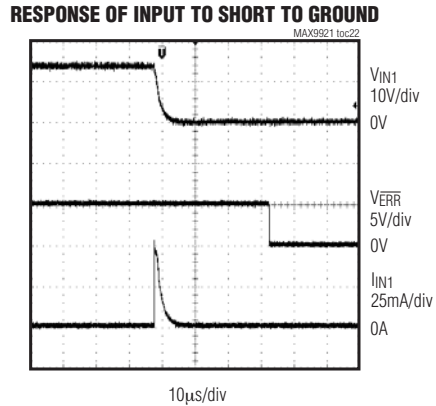
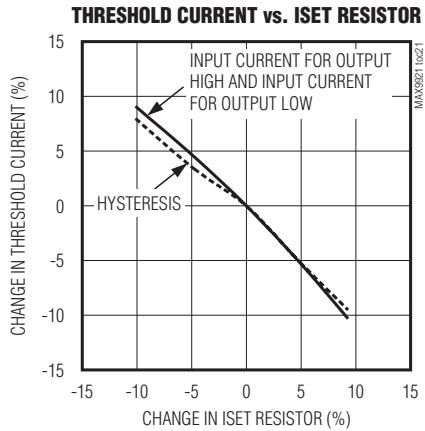
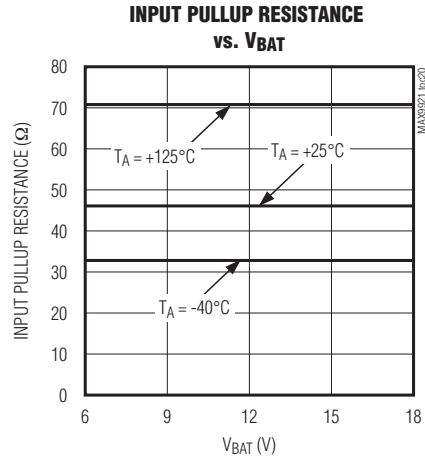
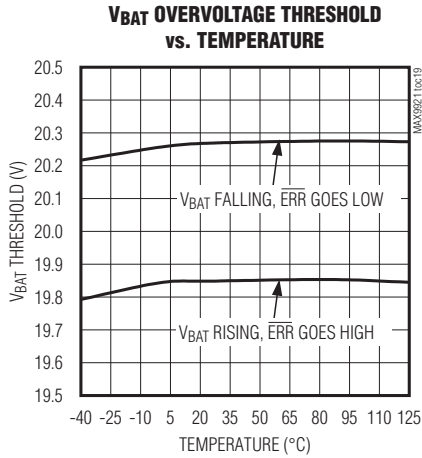

STARTUP OF HALL INPUT FROM SHUTDOWN

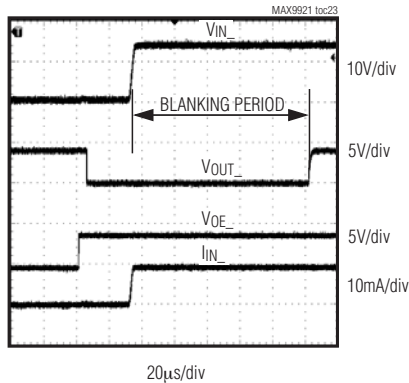

Dual, 2-Wire Hall-Effect Sensor Interface with Diagnostics

Pin Description

MAX9921

| PIN | NAME | FUNCTION |
|-----|------------------|---|
| 1 | BAT | Battery Power Supply. Connect BAT to the positive supply through an external reverse-polarity diode. Bypass BAT to ground with a 0.1 μ F capacitor. |
| 2 | ISET | Current-Setting Input. Connect a 63.4k Ω , 1% resistor (R_{ISET}) between BAT and ISET to set the standard current thresholds for Hall current sensing. Make no other connections to ISET. All routing must have low parasitic capacitance. |
| 3 | IN1 | Hall-Effect Sensor Input 1. Bypass IN1 to BAT or GND with a 0.01 μ F capacitor. Terminate an unused input with a 1.5k Ω resistor from IN1 to GND to prevent false error diagnostics. |
| 4 | IN2 | Hall-Effect Sensor Input 2. Bypass IN2 to BAT or GND with a 0.01 μ F capacitor. Terminate an unused input with a 1.5k Ω resistor from IN2 to GND to prevent false error diagnostics. |
| 5 | GND | Ground |
| 6 | OUT2 | Open-Drain Output Signal 2. OUT2 is the signal translated from Hall Sensor 2. Connect a 10k Ω or larger pullup resistor to logic supply. |
| 7 | OUT1 | Open-Drain Output Signal 1. OUT1 is the signal translated from Hall Sensor 1. Connect a 10k Ω or larger pullup resistor to logic supply. |
| 8 | \overline{ERR} | Open-Drain Diagnostic and Error Output. Connect a 10k Ω or larger pullup resistor to logic supply. If DIAG is asserted low, a high on \overline{ERR} indicates that there is no fault while a low on \overline{ERR} indicates that either the battery voltage is out of range or there is a fault condition. If DIAG is high, \overline{ERR} provides diagnostic information in conjunction with OUT1 and OUT2. See Tables 1 and 2. If OE is low or while in shutdown, \overline{ERR} is high impedance. |
| 9 | OE | Output Enable Input. OE has an internal 80k Ω resistor to GND. Drive OE high to enable the outputs \overline{ERR} , OUT1, and OUT2. Drive OE low to place the outputs in high impedance. If OE and DIAG are both low for more than 40 μ s, the device enters shutdown and all outputs are in high impedance. While in shutdown, if either OE or DIAG transitions low to high, the device exits shutdown mode. |
| 10 | DIAG | Diagnostic Enable Input. DIAG has an internal 80k Ω resistor to GND. Drive DIAG low for normal operation. In this mode, \overline{ERR} , OUT1, and OUT2 provide Hall sensor information. Drive DIAG high for diagnostic operation. A high-to-low transition initiates an attempt to restart, with a blanking cycle any Hall input that has been shut down. See Tables 1 and 2 (diagnostic truth tables). If OE and DIAG are both low for more than 40 μ s, the device enters shutdown mode with all outputs in high impedance. While in the shutdown mode, if either OE or DIAG transitions low to high, the device exits shutdown mode. |

Dual, 2-Wire Hall-Effect Sensor Interface with Diagnostics

Functional Diagram

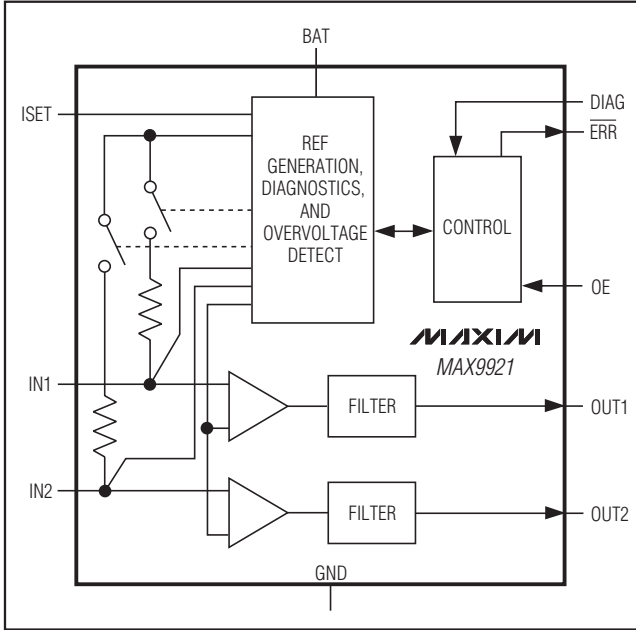

Detailed Description

The MAX9921 connects two 2-wire Hall-effect sensors to a low-voltage μP . This device supplies current through IN1 and IN2 to Hall sensors and monitors the current level drawn by the Hall sensors. The MAX9921 outputs a high or low logic-level to the corresponding open-drain output (OUT1 or OUT2). If the current flowing out of either IN1 or IN2 exceeds the high input current threshold, the corresponding output goes high. If the current flowing out of either IN1 or IN2 is lower than the low input current threshold, the corresponding output goes low.

Hall Input Diagnostic

Normal Mode

In normal mode, DIAG is driven low. In this case, if $\overline{\text{ERR}}$ is high, the outputs (OUT1 and OUT2) indicate the high or low state of the corresponding Hall sensors (IN1 and IN2). In normal mode, a low $\overline{\text{ERR}}$ indicates a fault. If $\overline{\text{ERR}}$ is low, the outputs may be pulled low and may not indicate the high or low state of the Hall sensors. This can happen during the power-up, restart, or blanking cycles of the Hall inputs, or due to a fault on one or both of the Hall inputs, or when V_{BAT} is out of range, while the error output is low. If one output continues signaling and the other output is low, the output with the low logic-level indicates a fault or a restart and blanking cycle on the corresponding Hall input. Table 1 summarizes normal mode operation.

Diagnostic Mode

When DIAG is driven high, the MAX9921 enters diagnostic mode. In this mode, OUT1 and OUT2 output diagnostic information. IN1 takes precedence over IN2. IN2's diagnostics remain masked until a fault on IN1 is cleared. For diagnostics and troubleshooting, when IN1 or IN2 shuts off due to an input short to ground, it continues to source $50\mu\text{A}$. A falling edge at DIAG restarts a Hall input that has been shut off due to a short to ground.

Diagnostic indications are never latched internally and they indicate the real-time state of IN1 or IN2. Table 2 summarizes diagnostic mode operation.

Hall Input Fault Detection

If a fault is detected, the ERR output is asserted low to notify the μP . This condition can occur due to the Hall input being shorted to ground, shorted to battery, or open.

Table 1. Diagnostic Truth Table (Normal Mode)

| INPUT | | OUTPUT | | DIAGNOSIS | COMMENT |
|-------|-------------------------|--------|--------|---|--|
| DIAG | $\overline{\text{ERR}}$ | OUT1 | OUT2 | | |
| 0 | 1 | 0 or 1 | 0 or 1 | OUT1 and OUT2 indicate state of IN1 and IN2, respectively | Normal mode: No fault indication (outputs indicate Hall sensor high or low status) |
| 0 | 0 | 0 | 0 | Fault on IN1 and/or IN2, or V_{BAT} out of range, or power-up or restart blanking (unknown current level of IN1 and IN2) | Normal mode: $\overline{\text{ERR}}$ asserted low indicates fault (outputs may no longer indicate the high or low state of the Hall sensors) |
| 0 | 0 | 0 | 0 or 1 | Fault on IN1 or restart blanking of IN1 | Normal mode: $\overline{\text{ERR}}$ asserted low indicates fault; Hall output 2 continues signaling |
| 0 | 0 | 0 or 1 | 0 | Fault on IN2 or restart blanking of IN2 | Normal mode: $\overline{\text{ERR}}$ asserted low indicates fault; Hall output 1 continues signaling |

Dual, 2-Wire Hall-Effect Sensor Interface with Diagnostics

MAX9921

Table 2. Diagnostic Truth Table (Diagnostic Mode)

| INPUT | | OUTPUT | | | DIAGNOSIS |
|-------|-------------------------|--------|------|--|-----------|
| DIAG | $\overline{\text{ERR}}$ | OUT1 | OUT2 | | |
| 1 | 0 | 0 | 0 | No fault | |
| 1 | 0 | 0 | 1 | IN1 open circuit, or IN1 open circuit and fault on IN2 | |
| 1 | 0 | 1 | 0 | IN1 shorted to battery, or IN1 shorted to battery and fault on IN2 | |
| 1 | 0 | 1 | 1 | IN1 shorted to ground, or IN1 shorted to ground and fault on IN2 | |
| 1 | 1 | 0 | 0 | V _{BAT} out of range, or power-up or restart and blanking cycle (dominant fault masks all other faults) | |
| 1 | 1 | 0 | 1 | IN2 open circuit | |
| 1 | 1 | 1 | 0 | IN2 shorted to battery | |
| 1 | 1 | 1 | 1 | IN2 shorted to ground | |

Hall Sensor Protection from Supply Transients

If the V_{BAT} voltage is lower than 6V or exceeds 18V, IN1 and IN2 shut off current to both Hall sensors and $\overline{\text{ERR}}$, OUT1, and OUT2 go low. When V_{BAT} returns to the proper range, both IN1 and IN2 restart, following a blanking cycle.

Hall Inputs Open Condition

If either IN1 or IN2 is open ($I_{IN} < 2\text{mA}$), the corresponding input shuts off current to the Hall sensor. If IN1 or IN2 is loaded, it exits the open input fault condition and restarts the corresponding Hall input, following a blanking cycle.

Hall Input Shorted to Battery

If either IN1 or IN2 is shorted to the battery ($V_{IN} > V_{BAT} + 100\text{mV}$), the MAX9921 shuts off current to the corresponding Hall sensor. In this case, if IN1 or IN2 is more than 1V above V_{BAT}, it may back-drive current into BAT. In such a condition, the current level in the Hall input should not exceed 100mA. Therefore, all the MAX9921s together can share a separate reverse-polarity protection diode to avoid powering up other circuitry sharing a common diode (Figure 3).

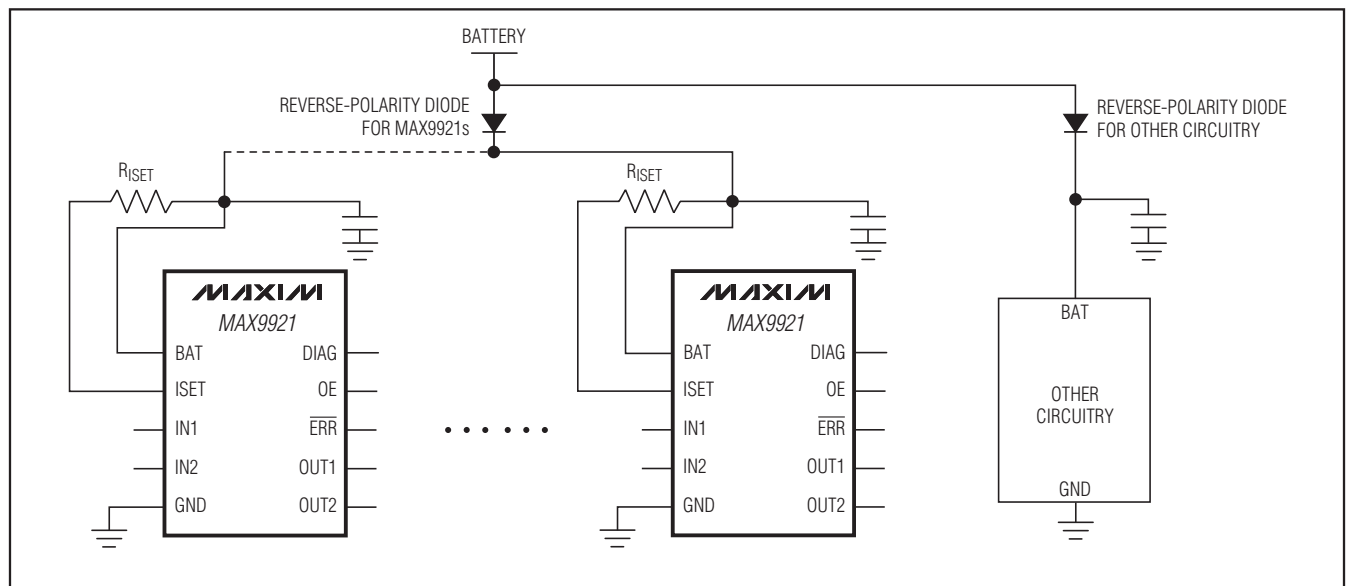

Figure 3. Several MAX9921s Connected to a Common Reverse-Polarity Diode

Dual, 2-Wire Hall-Effect Sensor Interface with Diagnostics

Hall Input Short-to-Ground

The Hall input shorted-to-ground fault is effectively a latched condition if the input remains loaded by the Hall switch when the shorting condition is removed. The current required to power the Hall switch is shut off and only a $50\mu\text{A}$ pullup current remains. The Hall input can be manually re-energized or it can be re-energized by the ECU. A falling edge at DIAG initiates a restart with a blanking cycle of any Hall input that has been shut down due to the shorted-to-ground condition. During startup or restart, it is possible for a Hall input to charge up an external capacitance of $0.02\mu\text{F}$ without tripping into a shorted-to-ground latched state. All other fault conditions are not latched and when these other faults are removed, $\overline{\text{ERR}}$ goes high and the Hall input is again functional.

Manual Method for Re-Energizing Hall Sensor and Means for Diagnosing an Intermittent Hall Sensor Connection

Figure 4 shows the behavior of the MAX9921 when a Hall input is open. Figure 5 shows the behavior of the MAX9921 when the open input is reconnected to a Hall sensor. Figures 4 and 5 demonstrate how a shorted-to-ground Hall input can be reset.

Resetting a shorted-to-ground Hall input involves three steps:

- 1) Relieve the short to ground at the Hall sensor.
- 2) Disconnect the Hall input from the Hall sensor (open input fault condition).
- 3) Reconnect the Hall input to the Hall sensor.

The MAX9921 restarts the Hall input with a blanking cycle. If the Hall input is disconnected from the Hall sensor for 10ms, it allows the Hall input to be pulled up by the $50\mu\text{A}$ pullup current to register the open-input fault condition. Then, reconnecting the Hall input to the Hall sensor restarts the Hall input with a blanking cycle. This provides a manual means of re-energizing a Hall input without having to resort to the ECU to reset it. This also demonstrates that an intermittent connection to a Hall sensor can recover without intervention of the ECU. This gives the ECU a means of diagnosing an intermittent connection to a Hall sensor by using the diagnostic mode to detect a diagnostic sequence of "open-circuit" to "blanking cycle" to "no fault."

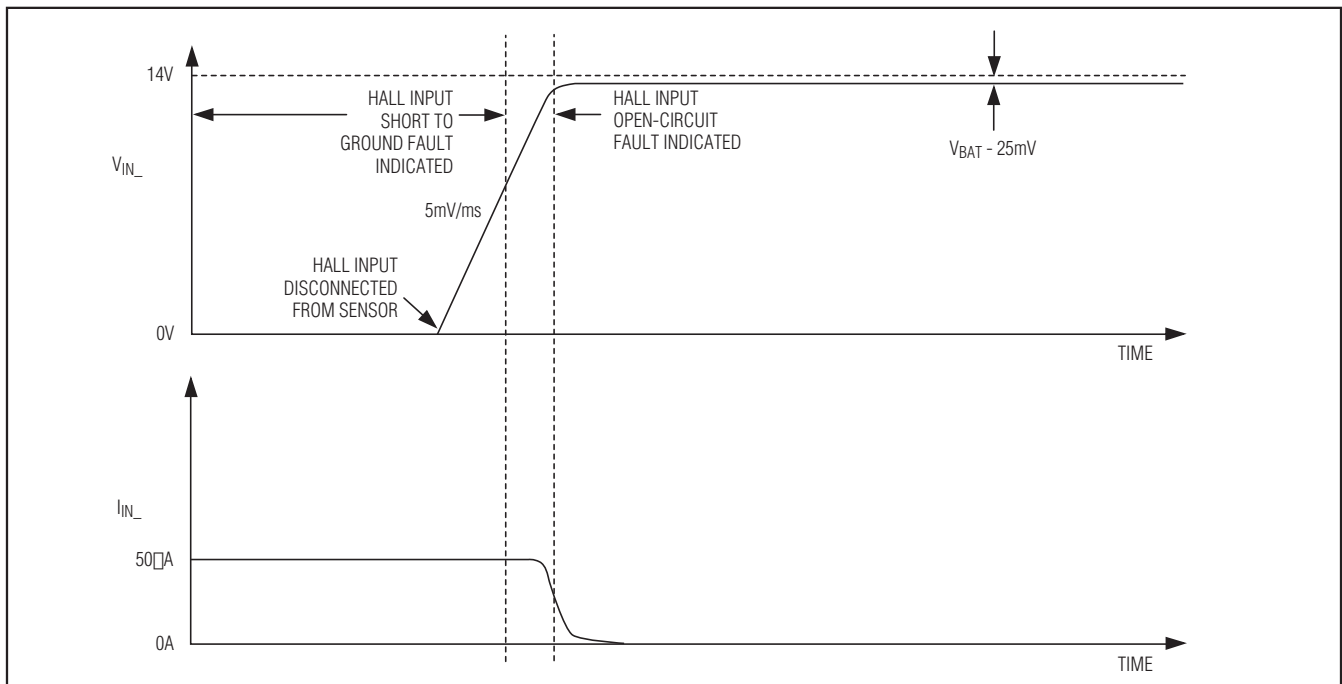

Figure 4. Hall Input Ramps to Open-Circuit Fault When Short to Ground is Relieved

Dual, 2-Wire Hall-Effect Sensor Interface with Diagnostics

MAX9921

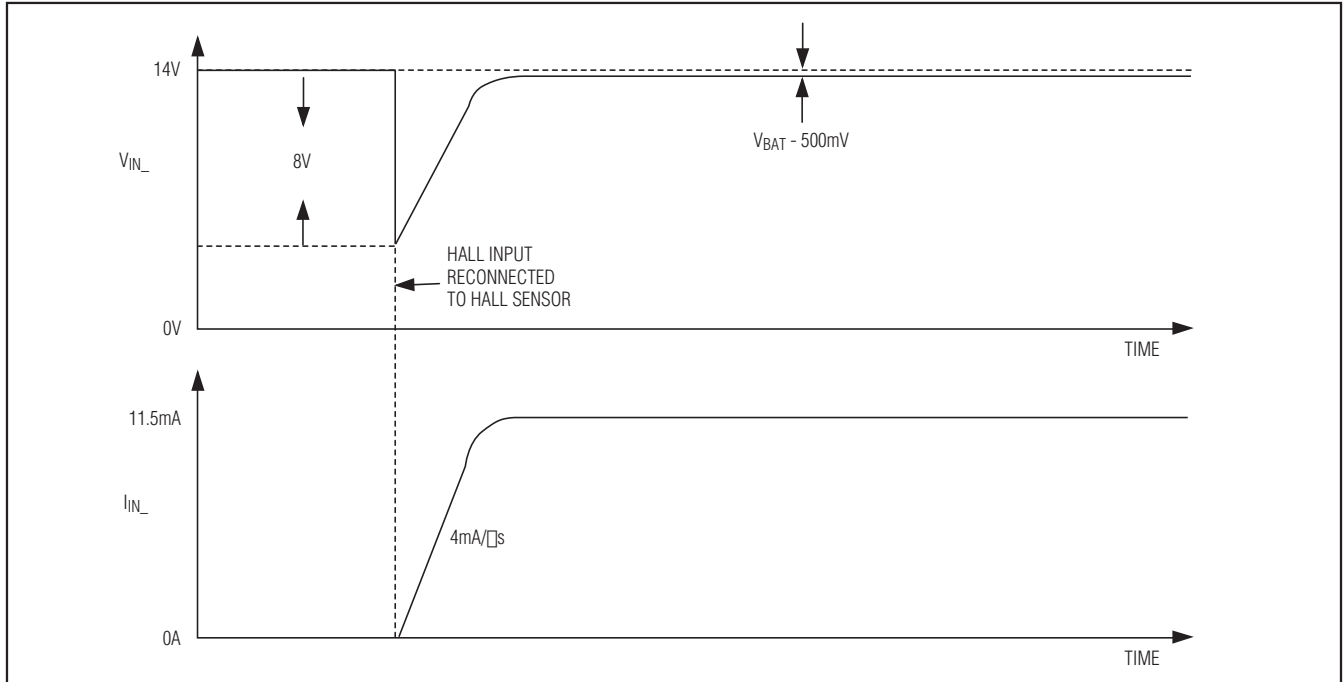

Figure 5. Hall Input Re-Energized When Open Input is Reconnected to Hall Sensor

Table 3. Summary of Fault Protection and Recovery

| FAULT DESCRIPTION | CRITERION | MAX9921 ACTIONS | | COMMENT/RECOVERY |
|-------------------------------|---|--------------------------------|---|---|
| | | $\overline{\text{ERR}}$ OUTPUT | HALL INPUT RESPONSE | |
| $V_{\text{BAT}} < 6\text{V}$ | — | Asserted low | Shutoff current to both Hall sensors | Both IN1 and IN2 are restarted with blanking cycle when V_{BAT} returns to proper range. |
| $V_{\text{BAT}} > 18\text{V}$ | — | Asserted low | Shutoff current to both Hall sensors | Both IN1 and IN2 are restarted with blanking cycle when V_{BAT} returns to proper range. |
| Hall input open | $I_{\text{IN}} < 2\text{mA}$ | Asserted low | Shutoff current to corresponding Hall sensor | When a Hall input is again loaded, terminating open input condition, the Hall input are restarted with blanking cycle. |
| Hall input shorted to battery | $V_{\text{IN}} > V_{\text{BAT}}$ due to external reverse-battery protection diode | Asserted low | Shutoff current to corresponding Hall sensor | If a Hall input is pulled more than 1V above V_{BAT} , the input may back drive current into the BAT supply and pull V_{BAT} up with it. In this condition, current levels in the Hall inputs should never exceed 100mA. For this reason, it is recommended that one or more MAX9921s be powered together and share a reverse-polarity diode separate from other circuitry. |
| Hall input shorted to ground | $I_{\text{IN}} > 23\text{mA}$ | Asserted low | Shutoff current to corresponding Hall sensor. $50\mu\text{A}$ of pullup current is sourced to IN1 or IN2 to aid in troubleshooting. | A falling edge at DIAG initiates a restart with a blanking cycle of any Hall input that has been shut off due to a short to ground. See the <i>Hall Input Short-to-Ground</i> section. |

Dual, 2-Wire Hall-Effect Sensor Interface with Diagnostics

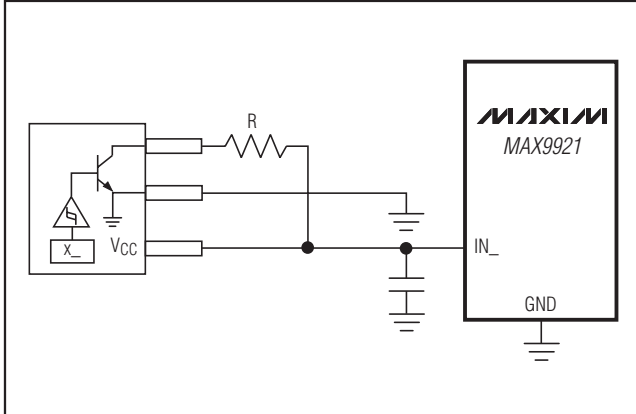

Figure 6. 3-Wire Hall-Effect Switches Configured as 2-Wire

Applications Information

Hall-Effect Sensor Selection

The MAX9921 is optimized for use with 2-wire Hall-effect switches or with 3-wire Hall-effect switches connected as 2-wire (Figure 6). When using a 3-wire Hall sensor, the resistor R is chosen so that the current drawn by the Hall sensor crosses the MAX9921 current threshold when the magnetic threshold of the Hall sensor is exceeded.

Table 4 shows a partial list of Hall sensors (primarily 2-wire) that can be used with the MAX9921. The DC Electrical Characteristics Table gives tested I_{IH}/I_{IL} current threshold limits for both a lower current range and

a higher current range which correspond to the selection of the R_{ISET} resistor value. This makes the MAX9921 compatible with a wide array of 2- and 3-wire Hall sensors.

Hall Input Bypass Capacitor

The MAX9921 is optimized for use with external protection 0.01 μ F capacitors from both IN1 and IN2 to BAT. These are essential to ensure robustness against automotive transients. These capacitors may be tied to GND instead of to BAT, but the connection to BAT is recommended.

Low-Voltage Operation

To ensure correct operation of the Hall sensor at low input voltages, it is important to consider the voltage drop of the MAX9921 with low battery voltages. This dropout voltage can be calculated using the formula:

$$V_{DROPOUT} = I_{HALL} \times R_{PU}$$

I_{HALL} is the maximum current which must be supplied to the Hall sensor and R_{PU} is the internal resistance of the MAX9921, nominally 50 Ω (see the Input Pullup Resistance vs. V_{BAT} graph in the *Typical Operating Characteristics*). As an example, assume the use of a HAL573 sensor, which draws a maximum current of 17mA. The dropout voltage is then 850mV and the approximate minimum voltage supplied to the Hall sensor is $6V - 0.85V = 5.15V$, which is higher than the minimum operating voltage of 3.75V specified for the HAL573.

Table 4. Partial List of Compatible Hall Switches

| PART | MANUFACTURER | WEBSITE | COMMENT |
|----------------|--------------|----------------------|---------|
| HAL573-6 | Micronas | www.micronas.com | 2-wire |
| HAL556/560/566 | Micronas | www.micronas.com | 2-wire |
| HAL581/584 | Micronas | www.micronas.com | 2-wire |
| A1140/1/2/3 | Allegro | www.allegromicro.com | 2-wire |
| A1180/81/82/83 | Allegro | www.allegromicro.com | 2-wire |

Note: The Hall switches listed above are supported by the MAX9921 using $R_{ISET} = 63.4k\Omega$.

Dual, 2-Wire Hall-Effect Sensor Interface with Diagnostics

MAX9921

Pin Configuration

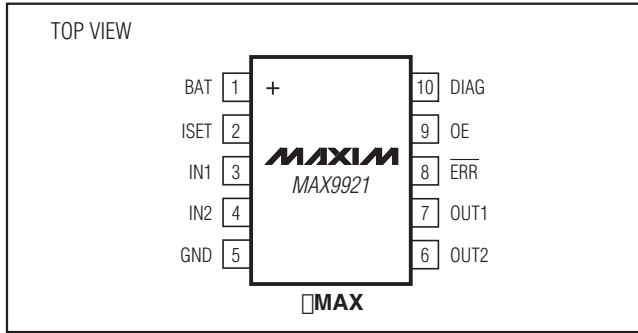

Chip Information

PROCESS: BiCMOS

Package Information

For the latest package outline information and land patterns, go to www.maxim-ic.com/packages. Note that a "+", "#", or "-" in the package code indicates RoHS status only. Package drawings may show a different suffix character, but the drawing pertains to the package regardless of RoHS status.

| PACKAGE TYPE | PACKAGE CODE | DOCUMENT NO. |
|--------------|--------------|-------------------------|
| 10 μ MAX | U10+2 | 21-0061 |

Dual, 2-Wire Hall-Effect Sensor Interface with Diagnostics

Revision History

| REVISION NUMBER | REVISION DATE | DESCRIPTION | PAGES CHANGED |
|-----------------|---------------|--|---------------|
| 0 | 6/08 | Initial release | — |
| 1 | 1/10 | Added limits to show compatibility with second set of Hall sensor thresholds, removed TLE4941/C from list of recommended Hall sensors, and added automotive part | 1, 2, 14 |

Maxim cannot assume responsibility for use of any circuitry other than circuitry entirely embodied in a Maxim product. No circuit patent licenses are implied. Maxim reserves the right to change the circuitry and specifications without notice at any time.

16 **Maxim Integrated Products, 120 San Gabriel Drive, Sunnyvale, CA 94086 408-737-7600**

X-ON Electronics

Largest Supplier of Electrical and Electronic Components

Click to view similar products for [Sensor Interface](#) category:

Click to view products by [Maxim](#) manufacturer:

Other Similar products are found below :

[ZSC31150GEG1-T](#) [ZSSC4161BE2W](#) [LM1815MX/NOPB](#) [MAX31850KATB+](#) [FM-252-4](#) [FM-215-8](#) [FM-216-AR2](#) [FM-253-4-P](#) [AS8510-ASSM](#) [AD598JRZ](#) [AD598SD/883B](#) [743478D](#) [AD698APZ](#) [AD698SQ](#) [ADA4558WHCPZ-R7](#) [ADPD4000BCBZR7](#) [ADPD4001BCBZR7](#) [MAX31855SASA+](#) [MAX31855TASA+](#) [DRV401AIDWPR](#) [AS89010](#) [MAX31855SASA+T](#) [MAX1358BETL+](#) [MAX31855EASA+](#) [MAX31855KASA+](#) [MAX31855NASA+](#) [MAX31911AUI+](#) [RE46C803SS20](#) [MAX1452AAE+](#) [MAX9926UAEE+](#) [RE46C800SS20](#) [SSC7102-GQ-AB2](#) [MAX6675ISA+](#) [MAX6674ISA+](#) [MAX31855RASA+](#) [MAX6675ISA+T](#) [FM-252-4-P](#) [SNJ306](#) [ZSSC4132CE4W](#) [BD9251FV-E2](#) [XTR110KU](#) [LM1815M/NOPB](#) [PGA302EPWT](#) [PGA308AIDRKT](#) [PGA309AIPWR](#) [RCV420JP](#) [TDC7200PWR](#) [XTR106UA/2K5](#) [TPIC8101DW](#) [TPIC8101DWR](#)