

MAXFILTERBRD

Evaluates: MAX7408–MAX7415/ MAX7418–MAX7425

General Description

The MAXFILTERBRD is an unpopulated PCB design to evaluate the MAX7408–MAX7415/MAX7418–MAX7425 5th-order, lowpass, switched-capacitor filters (SCFs).

Contact the factory for free samples of the pin-compatible MAX7408–MAX7415/MAX7418–MAX7425 SCFs to evaluate these devices.

Features

- ◆ CLK Pad for External Clock Frequency
- ◆ Lead(Pb)-Free and RoHS Compliant
- ◆ Proven PCB Layout

Ordering Information

PART	TYPE
MAXFILTERBRD+	EV Kit

+Denotes lead(Pb)-free and RoHS compliant.

Part Selection Table

PART	OPERATING VOLTAGE	FILTER TYPE
MAX7408CUA+	5V	Elliptic
MAX7409CUA+	5V	Bessel
MAX7410CUA+	5V	Butterworth
MAX7411CUA+	5V	Elliptic
MAX7412CUA+	3V	Elliptic
MAX7413CUA+	3V	Bessel
MAX7414CUA+	3V	Butterworth
MAX7415CUA+	3V	Elliptic
MAX7418CUA+	5V	Elliptic
MAX7419CUA+	5V	Bessel
MAX7420CUA+	5V	Butterworth
MAX7421CUA+	5V	Elliptic
MAX7422CUA+	3V	Elliptic
MAX7423CUA+	3V	Bessel
MAX7424CUA+	3V	Butterworth
MAX7425CUA+	3V	Elliptic

Note: Contact the factory to order a free sample of any of the SCF parts.

Component List (Suggested Components)

DESIGNATION	QTY	DESCRIPTION
C1	0	Not installed, 47pF ±5%, 50V COG ceramic capacitor (0805) Murata GRM2165C1H470J or similar
C2	0	Not installed, 2200pF ±5%, 50V COG ceramic capacitor (0805) Murata GRM2165C1H222J or similar
C3, C4	0	Not installed, 0.1µF ±10%, 16V X7R ceramic capacitors (0603) Murata GCM188R71C104K or similar
JU1, JU2	0	Not installed, 2-pin headers—shorted by PC trace
R1	0	Not installed, 10kΩ ±1% resistor (0805)
U1	0	Not installed, lowpass SCF (8 µMAX®) See the Part Selection Table
—	1	PCB: MAXFILTERBRD+

Component Supplier

SUPPLIER	PHONE	WEBSITE
Murata Electronics North America, Inc.	770-436-1300	www.murata-northamerica.com

Note: Indicate that you are using the MAXFILTERBRD when contacting this component supplier.

µMAX is a registered trademark of Maxim Integrated Products, Inc.

For pricing, delivery, and ordering information, please contact Maxim Direct at 1-888-629-4642, or visit Maxim's website at www.maximintegrated.com.

MAXFILTERBRD

Evaluates: MAX7408-MAX7415/ MAX7418-MAX7425

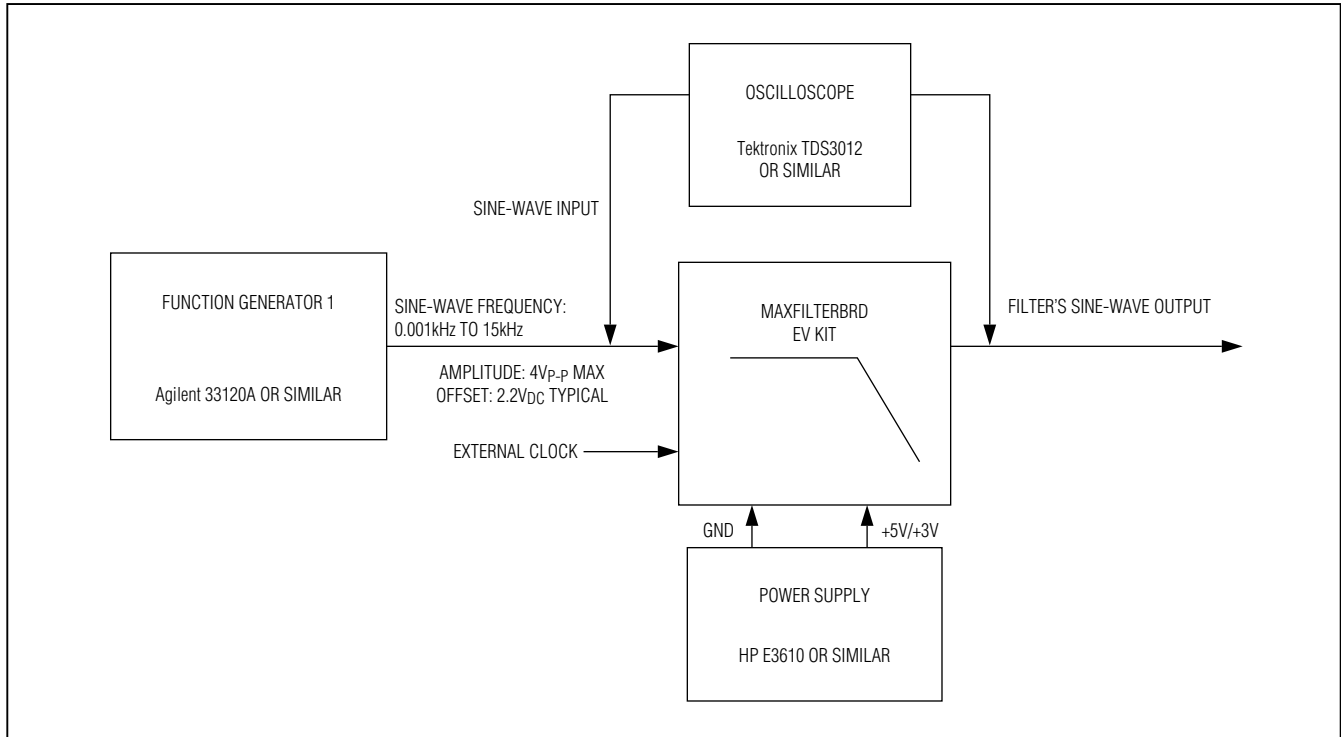

Figure 1. Filter Evaluation Test Block Diagram

Quick Start

Required Equipment

- MAXFILTERBRD
- Suggested components (see the *Component List*)
- 5V or 3V DC power supply (depending on the IC installed)
- Function generator (e.g., HP 33120A)
- 2-channel digital oscilloscope (e.g., Tektronix TDS3012)

Procedure

Caution: Do not turn on power supply until all connections are completed.

- 1) Install all suggested components shown in the *Component List* onto the MAXFILTERBRD.
- 2) If the installed IC is the MAX7408-MAX7411 or MAX7418-MAX7421, connect the positive terminal of

the 5V supply to the VDD pad and the negative terminal of the supply to the GND pad closest to the VDD pad. If the installed IC is the MAX7412-MAX7415 or MAX7422-MAX7425, connect the positive terminal of the 3V supply to the VDD pad and the negative terminal of the supply to the GND pad closest to the VDD pad (see Figure 1). Set the function generator to 4V_{p-p} max, 2.2V offset (typ), and 1kHz sine wave, and connect the signal to the IN pad.

- 3) Connect the first channel of the oscilloscope to the IN pad.
- 4) Connect the second channel of the oscilloscope to the OUT pad.
- 5) Connect the oscilloscope's ground probe to any GND pads.
- 6) Turn on the power supply.
- 7) Verify the output on the OUT pad.

MAXFILTERBRD

Evaluates: MAX7408–MAX7415/ MAX7418–MAX7425

Detailed Description of Hardware

The MAXFILTERBRD is an unpopulated PCB design to evaluate the MAX7408–MAX7415/MAX7418–MAX7425 5th-order, lowpass SCFs.

Internal Clock

The MAXFILTERBRD uses the internal oscillator when a capacitor is installed on C1. Refer to the corresponding installed IC data sheet.

For the MAX7409/MAX7410/MAX7413/MAX7414, the frequency can be altered using the following formula:

$$f_{OSC} \text{ (kHz)} = k/C1 \text{ (pF)}$$

where $k = 30 \times 10^3$ and f_{OSC} is the internal oscillator frequency.

For the MAX7408/MAX7411/MAX7412/MAX7415, $k = 27 \times 10^3$.

For the MAX7418/MAX7421/MAX7422/MAX7425, $k = 87 \times 10^3$.

For the MAX7419/MAX7420/MAX7423/MAX7424, $k = 110 \times 10^3$.

External Clock

An external clock that matches the specification of the corresponding IC data sheet can be used by cutting the trace of jumper JU2. Drive the CLK pin with a CMOS gate powered from 0 to VDD. Apply the clock signal to the CLK pad.

Shutdown

The MAXFILTERBRD is configured for normal operation once the desired IC is installed. The desired IC enters shutdown by cutting the trace of jumper JU1 and driving the IC \overline{SHDN} pin low through the side of the jumper that is still connected to the part.

MAXFILTERBRD

Evaluates: MAX7408-MAX7415/ MAX7418-MAX7425

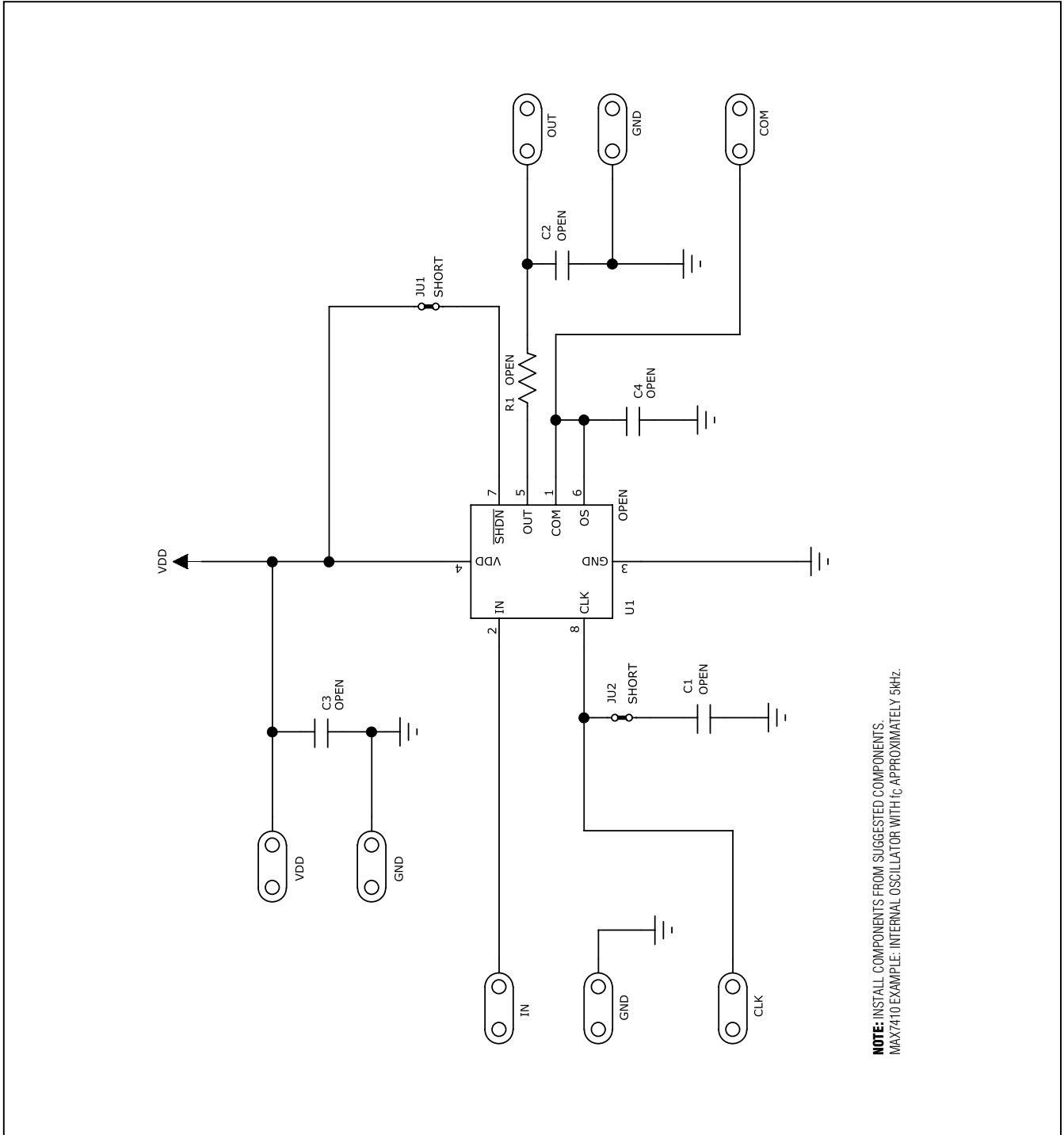

Figure 2. MAXFILTERBRD Schematic

MAXFILTERBRD

Evaluates: MAX7408-MAX7415/ MAX7418-MAX7425

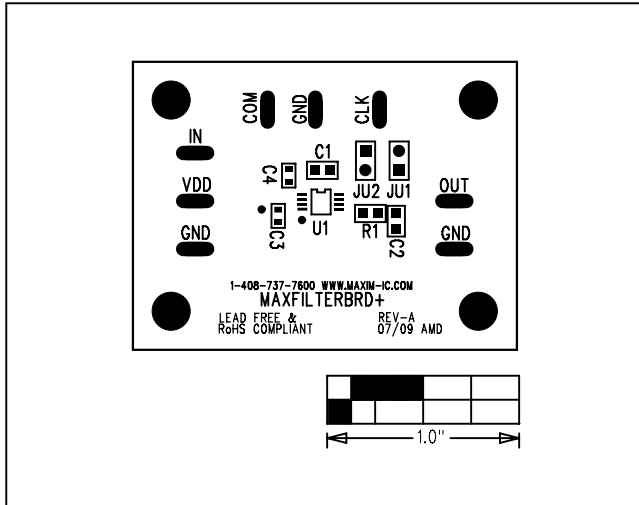

Figure 3. MAXFILTERBRD Component Placement Guide—Component Side

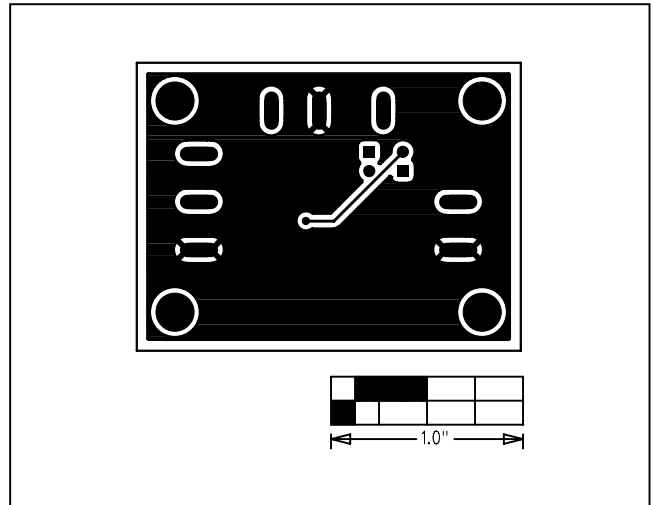

Figure 5. MAXFILTERBRD PCB Layout—Solder Side

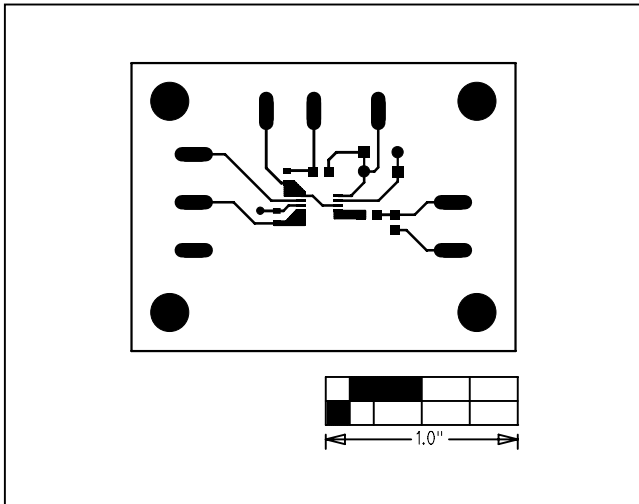

Figure 4. MAXFILTERBRD Component PCB Layout—Component Side

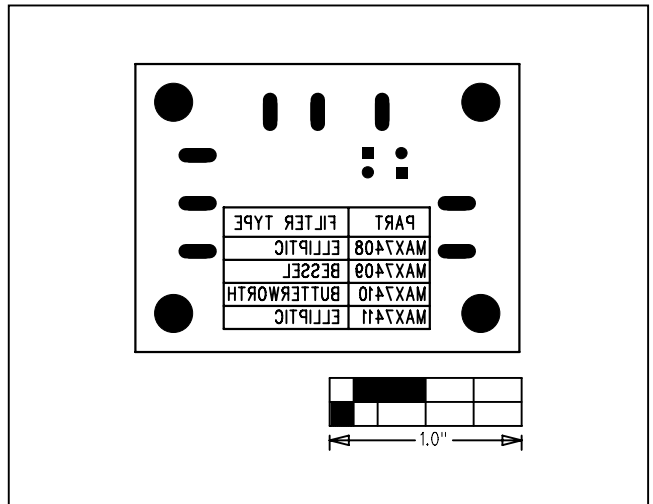

Figure 6. MAXFILTERBRD Component Placement Guide—Solder Side



Maxim Integrated cannot assume responsibility for use of any circuitry other than circuitry entirely embodied in a Maxim Integrated product. No circuit patent licenses are implied. Maxim Integrated reserves the right to change the circuitry and specifications without notice at any time. The parametric values (min and max limits) shown in the Electrical Characteristics table are guaranteed. Other parametric values quoted in this data sheet are provided for guidance.

X-ON Electronics

Largest Supplier of Electrical and Electronic Components

Click to view similar products for [Active Filter Development Tools](#) category:

Click to view products by [Maxim](#) manufacturer:

Other Similar products are found below :

[MAXFILTERBRD+](#) [DC1418A-A](#) [DC962A-B](#) [DC962A-E](#) [DC962A-A](#) [DC338B-B](#) [130521-HMC900LP5E](#) [131200-HMC900LP5E](#) [EVAL01-HMC1044LP3E](#) [AFS1410-EVAL](#) [AFS2016-EVAL](#) [ADMV8818-EVALZ](#) [EV1HMC881ALP5](#) [EVAL-FW-HPMFB2](#) [EVAL-FW-LPMFB2](#) [3-109-440](#) [3-111-353](#) [EVAL-FW-LPSK2](#) [EVAL-FW-MOTHER](#) [EVAL-FW-BPDF2](#) [EVAL-FW-HPMFB1](#) [EVAL-FW-HPSK2](#) [DC1251A-A](#) [885136-EVB](#) [3-115-037](#) [TPS7A3501EVM-547](#)