

Keywords: Corona, MAXREFDES12, subsystem reference design, digital input translator/serializer, digital input modules, PLC, home automation, industrial automation, process automation, motor control, isolated power and data

SUB-SYSTEM BOARD 5611

# Corona (MAXREFDES12#): Isolated Industrial Octal Digital Input Translator/Serializer

May 20, 2013

*Abstract: This document explains how the Corona (MAXREFDES12#) subsystem reference design provides a compact and simple isolated digital input interface for industrial control and automation applications. Hardware and firmware design files are provided.*

## Introduction

In industrial control, industrial automation, motor control, and process automation applications, binary/digital sensors and switches are frequently required. Systems often need many optocouplers for isolating each sensor channel. The Corona (MAXREFDES12#) subsystem reference design provides the front-end interface circuit of a programmable logic controller (PLC)

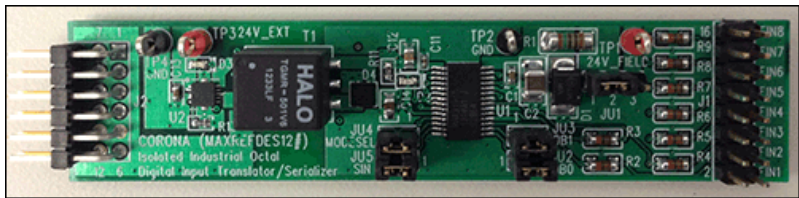

[More detailed image \(PDF, 5.9MB\)](#)

digital input module. The serialization feature allows a large reduction in the number of optocouplers used for isolation. The reference design accepts high-voltage inputs (36V, max) and features isolated power and data—all integrated into a small form factor. The Corona design integrates an octal, digital input translator/serializer (MAX31911), a data isolation device (MAX14850), and an H-bridge transformer driver for isolated power supply (MAX13256). The Corona digital input circuit solution is mainly targeted for digital input modules for PLCs, industrial automation, process automation, and motor control applications.

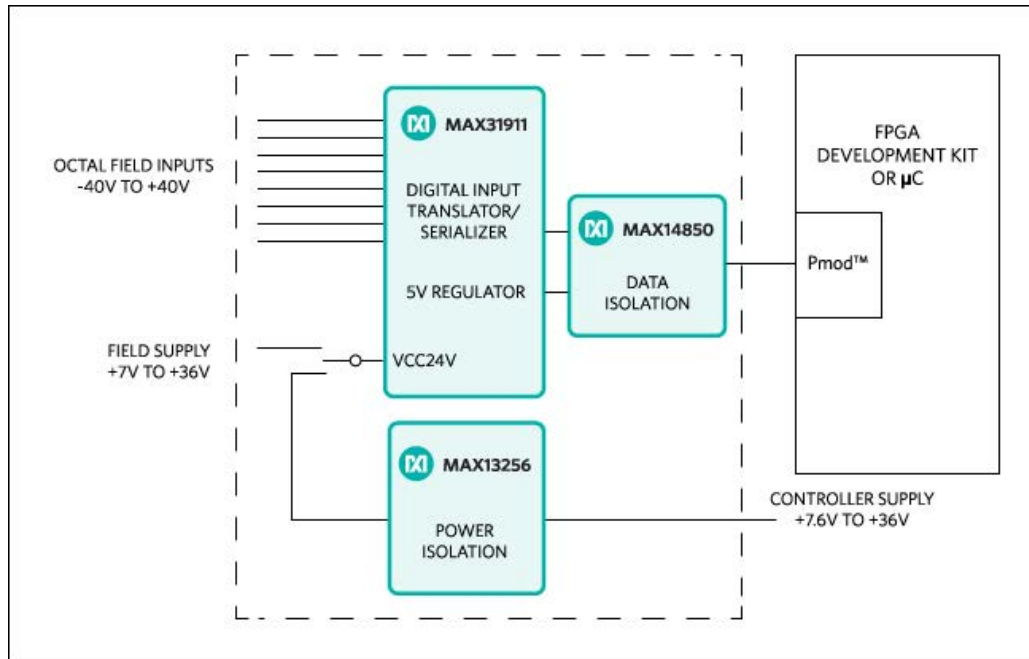

Figure 1. The Corona subsystem design block diagram.

## Features

- Eight high-voltage input channels (36V, max)
- On-chip 8-to-1 serialization with SPI interface
- On-chip 5V regulator
- Isolated power and data
- Small printed circuit board (PCB) area
- Device drivers
- Example C source code
- Pmod™-compatible form factor

## Applications

- Building automation
- Digital input modules for PLCs
- Industrial automation
- Motor control
- Process automation

## Detailed Description of Hardware

The Pmod specification allows for both 3.3V and 5V modules as well as various pin assignments. This module works with either 3.3V or 5V supply voltages and uses the SPI pin assignments as illustrated.

The power requirements are shown in **Table 1**. The currently supported platforms and ports are shown in **Table 2**.

Power Type	Jumper Shunt	Power Name	Input Voltage (V)	Input Current (mA, typ)
Isolated power	JU1: 1-2	U3 VCAA	3.3	19.4
			5	27.2
		U1 VCC24V	12	13.6
			24	14.5
Field power	JU1: 2-3	U3 VCAA	3.3	19.4
			5	27.2
		U1 VCC24V	12	8.2
			24	8.2

Supported Platforms	Ports
Nexys™ 3 platform (Spartan®-6)	JA1
ZedBoard™ platform (Zynq®-7020)	JA1

The Corona subsystem is an isolated, octal, digital input translator/serializer. The design includes an octal, digital input translator/serializer (MAX31911), an H-bridge transformer driver (MAX13256), and a six-channel digital isolator (MAX14850).

The MAX31911 (U1) industrial interface serializer translates, conditions, and serializes the 24V digital output of sensors and switches used in industrial, process, and building automation to CMOS-compatible signals required by microcontrollers. It provides the front-end interface circuit of a PLC digital input module. The device features integrated current limiting, lowpass filtering, and channel serialization. Input current limiting allows a significant reduction in power consumed from the field voltage supply as compared to traditional discrete resistor-divider implementations. Selectable on-chip lowpass filters allow flexible debouncing and filtering of sensor outputs based on the application. On-chip serialization allows a large reduction in the number of optocouplers used for isolation. For enhanced robustness with respect to high-frequency noise and fast electrical transients, a multibit CRC code is generated and transmitted through the SPI port for each 8 bits of data. The on-chip 5V voltage regulator can be used to power external optocouplers, digital isolators, or other external 5V circuitry.

The MAX13256 (U2) provides an isolated, functional insulation class power solution that accepts an 7.6V to 36V DC supply, and converts it to an isolated 7V to 36V DC supply with an off-the-shelf TGMR-501V6LF Halo® transformer with a 1:1 primary to

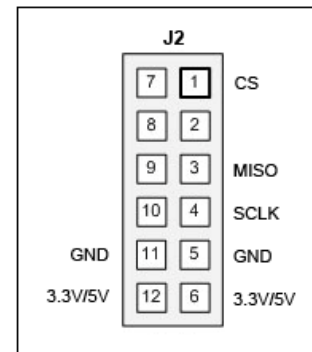

secondary turns ratio plus an external on-board full bridge rectifier.

The MAX14850 (U3) accomplishes data isolation. On the Pmod side, the voltage supply can be 3.3V or 5V. (The Pmod power output for both the Nexys 3 and ZedBoard platforms is fixed at 3.3V.) On the MAX31911 side, the voltage supply is 5V. The combined power and data isolation achieved is 600V<sub>RMS</sub>.

To use the on-board isolation circuits, move the shunt on jumper JU1 to the 1–2 position and apply 7.6V to 36V DC supply on terminals TP3 and TP4. If the on-board isolation circuit is not required, move the shunt on jumper JU1 to the 2-3 position and apply 7V to 36V DC supply on terminals TP1 and TP2. See Table 1 for the jumper settings and the input current requirements.

## Detailed Description of Firmware for Nexys 3 Platform

The Corona firmware design was developed and tested for the Nexys 3 development kit. The design targets a MicroBlaze™ soft core microcontroller placed inside a Xilinx® Spartan-6 FPGA. The FPGA project files for the Nexys 3 platform are located under [Firmware Files](#) in the [All Design Files](#) section.

The firmware is a working example of how to initiate the system and continuously read and display the MAX31911 register values. The simple process flow is shown in **Figure 2**. The firmware is written in C using the Xilinx SDK tool, which is based on the Eclipse™ open source standard. Custom Corona-specific design functions were created utilizing the standard Xilinx XSpi core version 3.03a. The SPI clock frequency is set to 3.125MHz.

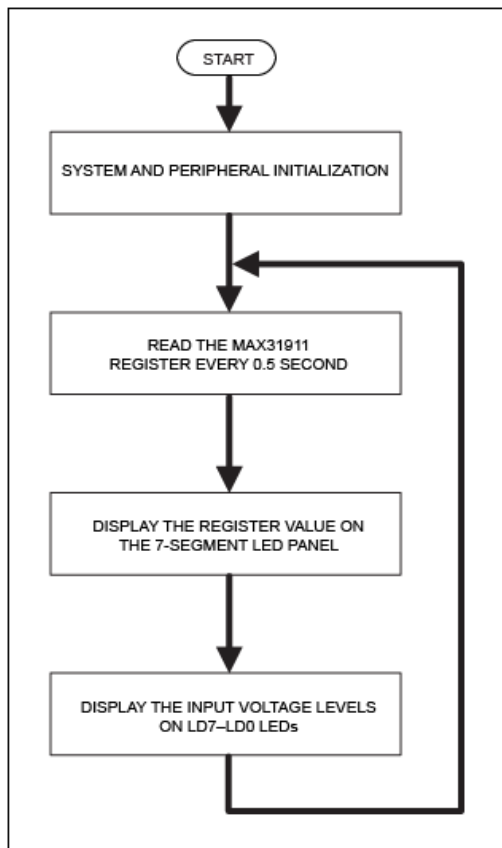

Figure 2. The Corona firmware flowchart for Nexys 3 platform.

The complete source code is provided to speed up customer development. Code documentation can be found with the corresponding firmware platform files.

## Detailed Description of Firmware for ZedBoard Platform

The Corona firmware design is also developed and tested for the ZedBoard kit. The design targets an ARM® Cortex®-A9 processor

placed inside a Xilinx Zynq system-on-chip (SoC). The FPGA project files for the ZedBoard platform are located under [Firmware Files](#) in the [All Design Files](#) section.

The firmware is a working example of how to initiate the system and continuously read and display the MAX31911 register values. The simple process flow is shown in **Figure 3**. The firmware is written in C using the Xilinx SDK tool, which is based on the Eclipse open source standard. Custom Corona-specific design functions were created utilizing the standard Xilinx XSpi core version 3.03a. The SPI clock frequency is set to 3.125MHz.

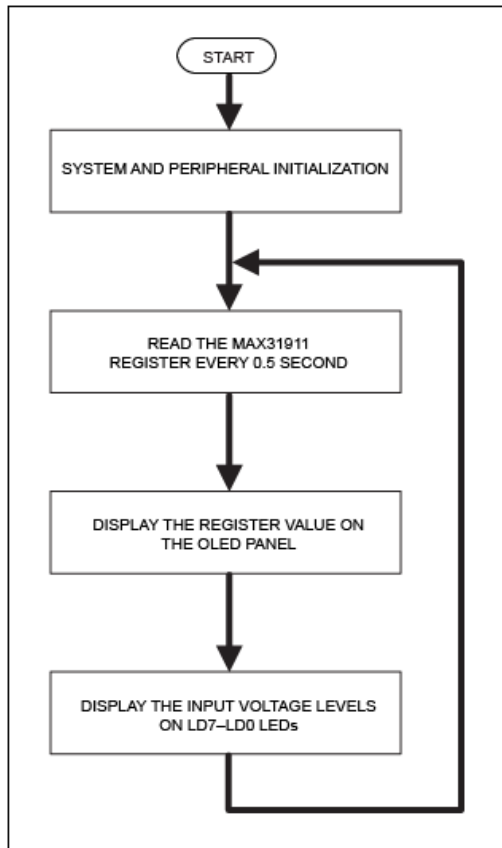

Figure 3. The Corona firmware flowchart for ZedBoard platform.

The complete source code is provided to speed up customer development. Code documentation can be found with the corresponding firmware platform files.

## Quick Start

Required equipment:

- Windows® PC with one USB port
- Corona (MAXREFDES12#) board
- Corona-supported platform (i.e., Nexys 3 development kit or ZedBoard kit)
- One 24V 1A DC power supply

Download, read, and carefully follow each step in the appropriate Corona Quick Start Guide:

[Corona \(MAXREFDES12#\) Nexys 3 Quick Start Guide](#)

[Corona \(MAXREFDES12#\) ZedBoard Quick Start Guide](#)

## Lab Operation

The following picture illustrates a test case for system operation on the ZedBoard platform. A 24V DC supply is applied on the TP3

and TP4 input power connectors. 24V is applied on channel 2 and channel 8 of the digital inputs. All other digital inputs are grounded. The OLED shows the register value as 0x8218. The LD7 (corresponding to input channel 8) and LD1 (corresponding to input channel 2) LEDs are lit up.

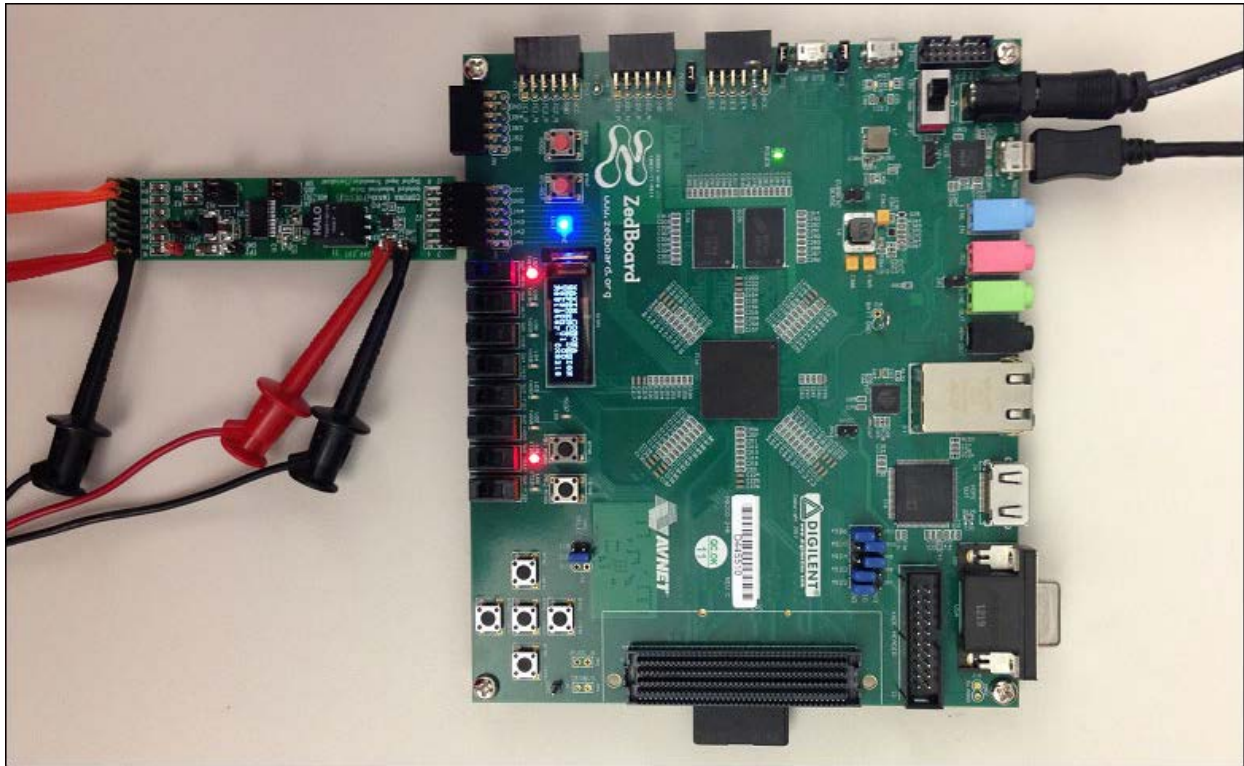

Figure 4. The Corona subsystem lab operation on the ZedBoard platform.

## All Design Files

[Download all design files.](#)

### Hardware Files

[Schematic](#)  
[Bill of materials \(BOM\)](#)  
[PCB layout](#)  
[PCB Gerber](#)  
[PCB CAD \(PADS 9.0\)](#)

### Firmware Files

[Nexys 3 platform \(Spartan-6\)](#)  
[ZedBoard platform \(Zynq\)](#)

## Buy Reference Design

[Corona \(MAXREFDES12#\)](#)

ARM is a registered trademark and registered service mark of ARM Limited.  
Cortex is a registered trademark of ARM Limited.  
Eclipse is a trademark of Eclipse Foundation, Inc.  
Halo is a registered trademark of Halo Electronics, Inc.  
MicroBlaze is a trademark of Xilinx, Inc.

Nexys is a trademark of Digilent Inc.  
Pmod is a trademark of Digilent Inc.  
Spartan is a registered trademark of Xilinx, Inc.  
Windows is a registered trademark and registered service mark of Microsoft Corporation.  
Xilinx is a registered trademark and registered service mark of Xilinx, Inc.  
ZedBoard is a trademark of ZedBoard.org.  
Zynq is a registered trademark of Xilinx, Inc.

Related Parts		
<a href="#">MAX13256</a>	36V H-Bridge Transformer Driver for Isolated Supplies	
<a href="#">MAX14850</a>	Six-Channel Digital Isolator	
<a href="#">MAX31911</a>	Industrial, Octal, Digital Input Translator/Serializer	<a href="#">Free Samples</a>
<a href="#">MAXREFDES12</a>	Corona (MAXREFDES12#): Isolated Industrial, Octal, Digital Input Translator/Serializer	

---

#### More Information

For Technical Support: <http://www.maximintegrated.com/support>

For Samples: <http://www.maximintegrated.com/samples>

Other Questions and Comments: <http://www.maximintegrated.com/contact>

---

Application Note 5611: <http://www.maximintegrated.com/an5611>

SUB-SYSTEM BOARD 5611, AN5611, AN 5611, APP5611, Appnote5611, Appnote 5611

© 2013 Maxim Integrated Products, Inc.

Additional Legal Notices: <http://www.maximintegrated.com/legal>

## X-ON Electronics

Largest Supplier of Electrical and Electronic Components

*Click to view similar products for [Interface Development Tools](#) category:*

*Click to view products by [Maxim](#) manufacturer:*

Other Similar products are found below :

[ADP5585CP-EVALZ](#) [CHA2066-99F](#) [AS8650-DB](#) [MLX80104 TESTINTERFACE](#) [416100120-3](#) [XR18910ILEVB](#) [XR21B1421IL28-0A-EVB](#) [TW-DONGLE-USB](#) [EVAL-ADM2491EEBZ](#) [MAXREFDES23DB#](#) [MAX13235EEVKIT](#) [DFR0257](#) [XR22404CG28EVB](#) [ZLR964122L](#) [ZLR88822L](#) [EVK-U23-01S](#) [EVK-W262U-00](#) [DC327A](#) [PIM511](#) [PIM536](#) [PIM517](#) [DEV-17512](#) [STR-FUSB3307MPX-PPS-GEVK](#) [MAXREFDES177#](#) [EVAL-ADM2567EEBZ](#) [ZSSC3240KIT](#) [MAX9121EVKIT](#) [PIM532](#) [ZSC31010KITV2P1](#) [UMFT4233HPEV](#) [LVDS-18B-EVK](#) [XR20M1170G16-0A-EB](#) [XR20M1170G16-0B-EB](#) [XR20M1170G24-0B-EB](#) [XR20M1172G28-0A-EB](#) [XR20M1172G28-0B-EB](#) [SI871XSOIC8-KIT](#) [1764](#) [1833](#) [1862](#) [EVB-USB82514](#) [ATA6628-EK](#) [ATA6631-EK](#) [EVAL-CN0313-SDPZ](#) [2264](#) [MCP23X17EV](#) [PS081-EVA-HR MODULE](#) [237](#) [SMA2RJ45EVK/NOPB](#) [FR12-0002](#)