

**MAXIM****Complete, 12-Bit Multiplying DAC****General Description**

The MX7845 is a 12-bit, voltage-output, 4-quadrant, multiplying digital-to-analog converter (DAC). A precision internal output amplifier and thin-film resistors, laser-trimmed at the wafer level, maintain accuracy over the full operating temperature range. The output amplifier is internally compensated and drives  $\pm 10V$  into a  $2k\Omega$  load.

The MX7845 has buffered latches that are easily interfaced with microprocessors. Data is transferred into the input register from a 12-bit-wide data path. The input registers are controlled by standard  $\overline{CS}$  (CS) and  $\overline{WR}$  (WR) signals. For stand-alone operation, the  $\overline{CS}$  and  $\overline{WR}$  inputs are grounded, making all latches transparent. All logic inputs are level-triggered and compatible with TTL and +5V CMOS logic levels. For a detailed description of MX7845 operation, refer to the MAX501/MAX502 data sheet.

**Applications**

Automatic Test Equipment  
 Digital Attenuators  
 Programmable Power Supplies  
 Programmable-Gain Amplifiers  
 Digital to 4-20mA Converters

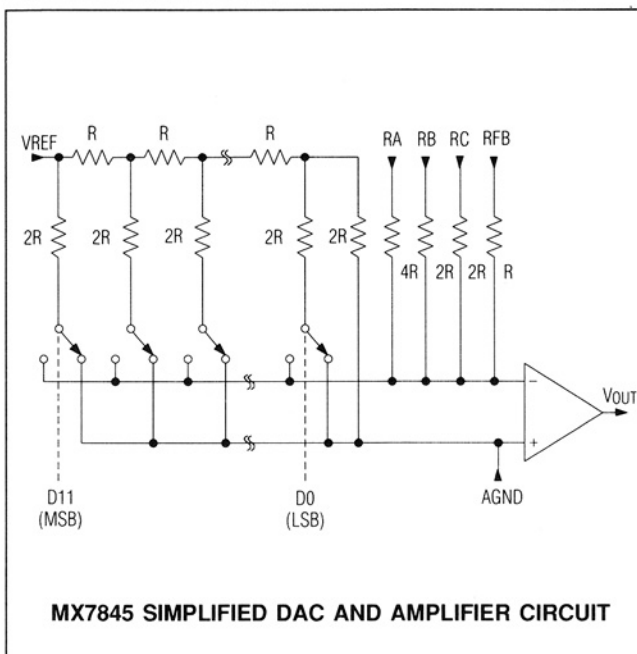
**Functional Diagram**

**MAXIM** is a registered trademark of Maxim Integrated Products.

**Features**

- ◆ Complete MDAC with Output Amplifier
- ◆ 4-Quadrant Multiplication
- ◆ Guaranteed Monotonic ( $T_{MIN}$  to  $T_{MAX}$ )
- ◆ Matched Application Resistors
- ◆ Small 0.3" 24-Pin DIP Package

**Ordering Information**

PART	TEMP. RANGE	PIN-PACKAGE
MX7845JN	0°C to +70°C	24 Narrow Plastic DIP
MX7845KN	0°C to +70°C	24 Narrow Plastic DIP
MX7845JR	0°C to +70°C	24 Wide SO
MX7845KR	0°C to +70°C	24 Wide SO
MX7845JP	0°C to +70°C	28 PLCC
MX7845KP	0°C to +70°C	28 PLCC
MX7845J/D	0°C to +70°C	Dice*
MX7845AEWG	-40°C to +85°C	24 Wide SO
MX7845BEWG	-40°C to +85°C	24 Wide SO
MX7845AQ	-40°C to +85°C	24 Narrow Cerdip
MX7845BQ	-40°C to +85°C	24 Narrow Cerdip
MX7845SE	-55°C to +125°C	28 LCC**
MX7845SQ	-55°C to +125°C	24 Narrow Cerdip**
MX7845TQ	-55°C to +125°C	24 Narrow Cerdip**

\* Contact factory for dice specifications.

\*\* Contact factory for availability and processing to MIL-STD-883.

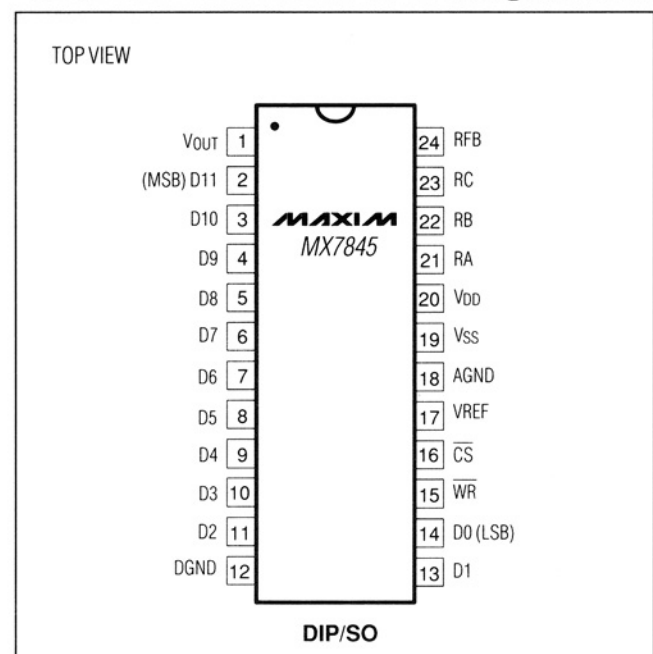
**Pin Configuration****MX7845****MAXIM**

Maxim Integrated Products 1

For pricing, delivery, and ordering information, please contact Maxim/Dallas Direct! at 1-888-629-4642, or visit Maxim's website at [www.maxim-ic.com](http://www.maxim-ic.com).

# Complete, 12-Bit Multiplying DAC

**MX7845**

## ABSOLUTE MAXIMUM RATINGS

V <sub>DD</sub> to DGND	-0.3V, +17V	Digital Input Voltage to DGND	-0.3V, V <sub>DD</sub> + 0.3V
V <sub>SS</sub> to DGND	+0.3V, -17V	Continuous Power Dissipation (any package)	650mW
V <sub>REF</sub> to AGND	±25V	to +75°C	10mW/°C
V <sub>RFB</sub> to AGND	±25V	derate above +75°C	10mW/°C
V <sub>RA</sub> to AGND	±25V	Operating Temperature Ranges:	
V <sub>RB</sub> to AGND	±25V	MX7845J_/K_	0°C to +70°C
V <sub>RC</sub> to AGND	±25V	MX7845A_/B_	-40°C to +85°C
V <sub>OUT</sub> to AGND (Note 1)	V <sub>DD</sub> + 0.3V, V <sub>SS</sub> - 0.3V	MX7845S_/T_	-55°C to +125°C
V <sub>DD</sub> to AGND	-0.3V, +17V	Storage Temperature Range	-65°C to +150°C
AGND to DGND	-0.3V, V <sub>DD</sub>	Lead Temperature (soldering, 10 sec)	+300°C

**Note 1:** V<sub>OUT</sub> may be shorted to AGND, V<sub>DD</sub>, or V<sub>SS</sub> if the package power dissipation is not exceeded.

Stresses beyond those listed under "Absolute Maximum Ratings" may cause permanent damage to the device. These are stress ratings only, and functional operation of the device at these or any other conditions beyond those indicated in the operational sections of the specifications is not implied. Exposure to absolute maximum rating conditions for extended periods may affect device reliability.

## ELECTRICAL CHARACTERISTICS

(V<sub>DD</sub> = +15V ±5%, V<sub>SS</sub> = -15V ±5%, V<sub>REF</sub> = +10V, AGND = DGND = 0V, V<sub>OUT</sub> connected to RFB, R<sub>L</sub> = 2kΩ, C<sub>L</sub> = 100pF, T<sub>A</sub> = T<sub>MIN</sub> to T<sub>MAX</sub>, all grades, unless otherwise noted.)

PARAMETER	SYMBOL	CONDITIONS		MIN	TYP	MAX	UNITS
<b>ACCURACY</b>							
Resolution	N			12			Bits
Relative Accuracy (Note 2)	INT	T <sub>A</sub> = +25°C	MX7845K/B/T			±1/2	LSB
			MX7845J/A/S			±1	
			MX7845K			±3/4	
			MX7845J/B/T			±1	
			MX7845A			±3/2	
MX7845S			±2				
Differential Nonlinearity	DNL					±1	LSB
Zero-Code Offset Error (Note 3)		T <sub>A</sub> = +25°C	MX7845K/B/T			±1	mV
			MX7845J/A/S			±2	
			MX7845K/B			±3	
			MX7845J/A/T			±4	
			MX7845S			±5	
Offset Temperature Coefficient	ΔVOS/ ΔTemp					±5	μV/°C
Gain Error		RFB, V <sub>OUT</sub> connected	MX7845K/B/T			±3	LSB
			MX7845J/A/S			±6	
		RC or RB, V <sub>OUT</sub> connected; V <sub>REF</sub> = 5V	MX7845K/B/T			±6	
			MX7845J/A/S			±9	
			MX7845K/B/T			±8	
MX7845J/A/S			±10				
Gain Temperature Coefficient	ΔGain/ ΔTemp	RFB, V <sub>OUT</sub> connected				±2	ppm of FSR/°C
Reference Input Resistance				8	12	16	kΩ
Application Resistor Ratio Matching		RA to RB to RC matching				0.5	%

# Complete, 12-Bit Multiplying DAC

MX7845

## ELECTRICAL CHARACTERISTICS (continued)

( $V_{DD} = +15V \pm 5\%$ ,  $V_{SS} = -15V \pm 5\%$ ,  $V_{REF} = +10V$ ,  $AGND = DGND = 0V$ ,  $V_{OUT}$  connected to RFB,  $R_L = 2k\Omega$ ,  $C_L = 100pF$ ,  $T_A = T_{MIN}$  to  $T_{MAX}$ , all grades, unless otherwise noted.)

PARAMETER	SYMBOL	CONDITIONS	MIN	TYP	MAX	UNITS
<b>DIGITAL INPUTS</b>						
Input Current	$I_{IN}$	$V_{IN} = 0V$ and $V_{DD}$			$\pm 1$	$\mu A$
Input Low Voltage	$V_{IL}$				0.8	V
Input High Voltage	$V_{IH}$		2.4			V
Input Capacitance	$C_{IN}$			5		pF
<b>POWER REQUIREMENTS</b>						
Supply Voltage (Note 4)	$V_{DD}$		14.25		15.75	V
	$V_{SS}$		-14.25		-15.75	
Supply Current	$I_{DD}$	$V_{OUT}$ unloaded			10	mA
	$I_{SS}$	$V_{OUT}$ unloaded			4	
Power-Supply Rejection	PSR	$V_{DD}$ only, $V_{REF} = -10V$			$\pm 0.2$	%/%
		$V_{SS}$ only			$\pm 0.2$	

**Note 2:** Guaranteed monotonic over temperature.

**Note 3:** DAC register loaded with all 0s.

**Note 4:** The MX7845 can operate from  $\pm 12V$  supplies.

## TIMING CHARACTERISTICS

( $V_{DD} = +15V \pm 5\%$ ,  $V_{SS} = -15V \pm 5\%$ ,  $V_{REF} = +10V$ ,  $AGND = DGND = 0V$ ,  $T_A = T_{MIN}$  to  $T_{MAX}$ , all grades, unless otherwise noted.) (Note 5)

PARAMETER	SYMBOL	CONDITIONS	MIN	TYP	MAX	UNITS
Chip Select to Write-Setup Time	$t_{CS}$	$T_A = +25^\circ C$	100			ns
		MX7845J/K/A/B	135			
		MX7845S/T	140			
Chip Select to Write-Hold Time	$t_{CH}$	$T_A = +25^\circ C$	0			ns
		MX7845J/K/A/B	0			
		MX7845S/T	0			
Write Pulse Width	$t_{WR}$	$T_A = +25^\circ C$	100			ns
		MX7845J/K/A/B	135			
		MX7845S/T	140			
Data-Setup Time	$t_{DS}$	$T_A = +25^\circ C$	100			ns
		MX7845J/K/A/B	100			
		MX7845S/T	120			
Data-Hold Time	$t_{DH}$	$T_A = +25^\circ C$	20			ns
			20			

**Note 5:** All input signal rise and fall times measured from 10% to 90% of +5V;  $t_r = t_f = 20ns$ . Timing measurement reference is  $(V_{IH} + V_{IL})/2$ .

# Complete, 12-Bit Multiplying DAC

## AC PERFORMANCE CHARACTERISTICS

( $T_A = T_{MIN}$  to  $T_{MAX}$ , all grades, unless otherwise noted.) (Note 6)

PARAMETER	SYMBOL	CONDITIONS	MIN	TYP	MAX	UNITS
<b>DYNAMIC PERFORMANCE</b>						
Output-Voltage Settling Time (Note 7)	$t_s$	$V_{OUT}$ LOAD = 2k $\Omega$ , 100pF		2.5	5.0	$\mu$ s
Slew Rate	SR	$V_{OUT}$ LOAD = 2k $\Omega$ , 100pF		7		V/ $\mu$ s
DAC Glitch Impulse (Note 8)				450		(nV)(s)
Multiplying Feedthrough Error (Note 9)				5		mV <sub>p-p</sub>
Unity-Gain Small-Signal Bandwidth (Note 10)		$V_{OUT}$ , RFB connected		600		kHz
Full-Power Bandwidth (Note 11)		$V_{OUT}$ , RFB connected, $R_L = 2k\Omega$		250		kHz
Total Harmonic Distortion (Note 12)	THD			-90		dB
<b>OUTPUT CHARACTERISTICS (Note 13)</b>						
Open-Loop Gain	$A_{VO}$	$V_{OUT} = \pm 10V$ , $R_L = 2k\Omega$	85			dB
Output Voltage Swing	$V_O$	$R_L = 2k\Omega$ , $C_L = 100pF$	$\pm 10$			V
Output Resistance	$R_O$	RFB, $V_{OUT}$ connected		0.2		$\Omega$
Short-Circuit Current		$V_{OUT}$ , AGND connected; $T_A = +25^\circ C$		15		mA
Output Noise Voltage (Note 14)		$T_A = +25^\circ C$	0.1Hz to 10Hz	2		$\mu$ V <sub>RMS</sub>
			f = 10Hz	250		nV $\sqrt{Hz}$
			f = 100Hz	100		
			f = 1kHz	50		
			f = 10kHz	50		
			f = 100kHz	50		

**Note 6:** AC PERFORMANCE CHARACTERISTICS are included for design guidance and are not subject to test.

**Note 7:** Settling to 0.01% of full-scale range. DAC register alternately loaded with all 0s and all 1s.

**Note 8:** Measured with  $V_{REF} = 0V$ . DAC register alternately loaded with all 1s and all 0s.

**Note 9:**  $V_{REF} = \pm 10V$ , 10kHz sine wave. DAC register loaded with all 0s.

**Note 10:** DAC register loaded with all 1s.  $V_{REF} = 100mV_{p-p}$  sine wave.

**Note 11:** DAC register loaded with all 1s.  $V_{REF} = 20V_{p-p}$  sine wave.

**Note 12:**  $V_{REF} = 6V_{RMS}$ , 1kHz sine wave.

**Note 13:** 2k $\Omega$  minimum specified load resistance.

**Note 14:** Includes output amplifier noise and Johnson Noise of RFB.

## Pin Description

DIP/SO	PLCC/LCC	NAME	FUNCTION
PIN	PIN		
1	2	$V_{OUT}$	Voltage Output
2-11	3-7, 9-13	D11-D2	Data Bits 2 to 11 (MSB)
12	14	DGND	Digital Ground
13, 14	16, 17	D1, D0	Data Bits 0 to 1 (LSB)
15	18	$\overline{WR}$	Write Input. Active Low.
16	19	$\overline{CS}$	Chip-Select Input. Active Low.
17	20	$V_{REF}$	Reference Input to DAC
18	21	AGND	Analog Ground

DIP/SO	PLCC/LCC	NAME	FUNCTION
PIN	PIN		
19	23	$V_{SS}$	-12V to -15V Supply Voltage Input
20	24	$V_{DD}$	+12V to +15V Supply Voltage Input
21	25	RA	Scaling Resistor: RA = 4RFB
22	26	RB	Scaling Resistor: RB = 2RFB
23	27	RC	Scaling Resistor: RC = 2RFB
24	28	RFB	Feedback Resistor
	1, 8, 15, 22	N.C.	No Connect

For application information, refer to the MAX501/MAX502 data sheet.

Maxim cannot assume responsibility for use of any circuitry other than circuitry entirely embodied in a Maxim product. No circuit patent licenses are implied. Maxim reserves the right to change the circuitry and specifications without notice at any time.

4 Maxim Integrated Products, 120 San Gabriel Drive, Sunnyvale, CA 94086 (408) 737-7600

## X-ON Electronics

Largest Supplier of Electrical and Electronic Components

*Click to view similar products for [Digital to Analog Converters - DAC category](#):*

*Click to view products by [Maxim manufacturer](#):*

Other Similar products are found below :

[5962-8876601LA](#) [PM7545FPCZ](#) [AD5311BRMZ-REEL7](#) [AD664AJ](#) [AD7534JPZ](#) [TCC-103A-RT](#) [057536E](#) [5962-89657023A](#) [702423BB](#)  
[TCC-202A-RT](#) [AD664BE](#) [TCC-303A-RT](#) [TCC-206A-RT](#) [AD5770RBCBZ-RL7](#) [DAC8229FSZ-REEL](#) [AD5673RBCPZ-2](#) [MCP48FVB24-20E/ST](#) [MCP48FVB28-E/MQ](#) [MCP48FEB18-20E/ST](#) [MCP48FEB18-E/MQ](#) [MCP48FEB24-E/MQ](#) [MCP48FEB28T-20E/ST](#)  
[MCP47FVB04T-E/MQ](#) [MCP48FEB28T-E/MQ](#) [MCP48FVB28T-20E/ST](#) [MCP47FVB28T-20E/ST](#) [MCP47FEB24T-E/MQ](#) [MCP48FVB18T-20E/ST](#) [MCP47FEB14T-E/MQ](#) [MCP47FEB08T-E/MQ](#) [MCP48FVB08T-20E/ST](#) [MCP47FEB04T-E/MQ](#) [MCP47FVB04T-20E/ST](#)  
[AD7524JRZ-REEL](#) [LTC1664CGN](#) [LTC1664IGN](#) [LTC7545ACSW](#) [MCP47DA1T-A1E/OT](#) [MCP4921-E/MC](#) [UC3910D](#) [DAC39J84IAAV](#)  
[DAC8218SPAG](#) [DAC8562TDGSR](#) [MAX545BCPD+](#) [DAC7641YB/250](#) [DAC7611PB](#) [DAC0800LCM](#) [TLV5638CDR](#) [TLC5615IDR](#)  
[DAC900TPWRQ1](#)