

# MAXIM

## +5V, +10V Precision Voltage References

REF01/REF02

### General Description

The REF01/REF02 are industry-standard precision voltage references. The stable 10V output of the REF01 can be adjusted over a  $\pm 6\%$  range with minimal effect on temperature stability. The 5V output REF02 can also be adjusted over a  $\pm 6\%$  range. The 10V REF01 has a single-supply operation over an input voltage range of 13V to 33V, while the 5V REF02 has a single-supply operation over an input voltage range of 7V to 33V. Both devices offer a low-current drain of 1mA. The REF02 also provides a TEMP pin whose output voltage varies linearly with temperature, making this device suitable for a wide variety of temperature-sensing and control applications. For new designs, refer to the MAX6035 or MAX6143 data sheets.

### Features

- ◆ Pretrimmed to +5V, +10V
- ◆ Excellent Temperature Stability: 3ppm/°C (typ)
- ◆ Low Noise: 10 $\mu$ Vp-p (REF02)
- ◆ Short-Circuit Protected
- ◆ Linear Temperature Transducer Output (REF02)

### Ordering Information

PART	TEMP RANGE	MAX TEMPCO (ppm/°C)	INITIAL ERROR (mV)	PIN-PACKAGE	PKG CODE
REF01EP	0°C to +70°C	8.5	$\pm 30$	8 Plastic DIP	P8-2
REF01EP+	0°C to +70°C	8.5	$\pm 30$	8 Plastic DIP	P8-2
REF01HP	0°C to +70°C	25	$\pm 50$	8 Plastic DIP	P8-2
REF01HP+	0°C to +70°C	25	$\pm 50$	8 Plastic DIP	P8-2
REF01HSA	0°C to +70°C	25	$\pm 50$	8 SO	S8-2
REF01HSA+	0°C to +70°C	25	$\pm 50$	8 SO	S8-2
REF01CP	0°C to +70°C	65	$\pm 100$	8 Plastic DIP	P8-2
REF01CP+	0°C to +70°C	65	$\pm 100$	8 Plastic DIP	P8-2
REF01CSA	0°C to +70°C	65	$\pm 100$	8 SO	S8-2
REF01CSA+	0°C to +70°C	65	$\pm 100$	8 SO	S8-2
REF01CESA	-40°C to +85°C	65	$\pm 100$	8 SO	S8-2
REF01CESA+	-40°C to +85°C	65	$\pm 100$	8 SO	S8-2

+Denotes a lead-free package.

Ordering Information continued at end of data sheet.

### Applications

Analog-to-Digital Converters  
 Digital-to-Analog Converters  
 Digital Voltmeters  
 Voltage Regulators  
 Threshold Detectors

### Typical Operating Circuit

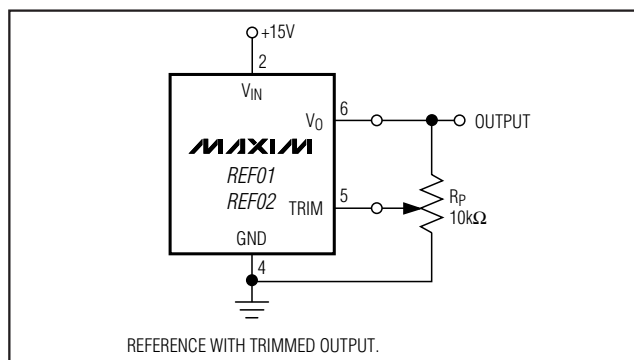

# +5V, +10V Precision Voltage References

## ABSOLUTE MAXIMUM RATINGS—REF01

Input Voltage	Output Short-Circuit Duration
REF01, E, H.....40V	(to ground or $V_{IN}$ ) .....Indefinite
REF01C .....30V	Storage Temperature Range .....-65°C to +150°C
Continuous Power Dissipation	Operating Temperature Range
Plastic Dip (P) (derate at 5.6mW/°C above +36°C) .....500mW	REF01E, REF01H, REF01C
Small Outline (S) (derate at 5.0mW/°C above +55°C) ..300mW	(except REF01CESA).....0°C to +70°C
	REF01CESA .....-40°C to +85°C
	Lead Temperature (soldering, 60s) .....+300°C

Stresses beyond those listed under "Absolute Maximum Ratings" may cause permanent damage to the device. These are stress ratings only, and functional operation of the device at these or any other conditions beyond those indicated in the operational sections of the specifications is not implied. Exposure to absolute maximum rating conditions for extended periods may affect device reliability.

## ELECTRICAL CHARACTERISTICS—REF01E/REF01H

( $V_{IN} = +15V$ ,  $T_A = +25^\circ C$ , unless otherwise noted.)

PARAMETER	SYMBOL	CONDITIONS	REF01E			REF01H			UNITS
			MIN	TYP	MAX	MIN	TYP	MAX	
Output Voltage	$V_O$	$I_L = 0$	9.97	10.00	10.03	9.95	10.00	10.05	V
Output Adjustment Range	$\Delta V_{trim}$	$R_P = 10k\Omega$	$\pm 3.0$	$\pm 6.0$		$\pm 3.0$	$\pm 6.0$		%
Output Voltage Noise	$e_{NP-P}$	0.1Hz to 10Hz (Note 1)		20	30		20	30	$\mu V_{P-P}$
Line Regulation		$V_{IN} = 13V$ to 33V (Note 2)		0.006	0.010		0.006	0.010	%/V
Load Regulation		$I_L = 0$ to 10mA (Note 2)		0.005	0.008		0.006	0.010	%/mA
Turn-On Settling Time	$t_{ON}$	To $\pm 0.1\%$ of final value		400			400		$\mu s$
Quiescent Supply Current	$I_{SY}$	No load		1.0	1.4		1.0	1.4	mA
Load Current	$I_L$	To specified output voltage tolerance	10	21		10	21		mA
Sink Current	$I_S$	To specified output voltage tolerance	0.3	0.5		0.3	0.5		mA
Short-Circuit Current	$I_{SC}$	$V_O = 0V$		30			30		mA

## ELECTRICAL CHARACTERISTICS—REF01E/REF01H

( $V_{IN} = +15V$ ,  $0^\circ C \leq T_A \leq +70^\circ C$  for REF01E and REF01H,  $I_L = 0mA$ , unless otherwise noted.)

PARAMETER	SYMBOL	CONDITIONS	REF01E			REF01H			UNITS
			MIN	TYP	MAX	MIN	TYP	MAX	
Output Voltage Change with Temperature	$\Delta V_{OT}$	$0^\circ C \leq T_A \leq +70^\circ C$ (Note 3)		0.02	0.06		0.07	0.17	%
Output Voltage Temperature Coefficient	$TCV_O$	(Note 4)		3	8.5		10.0	25.0	ppm/°C
Change in $V_O$ Temperature Coefficient with Output Adjustment		$R_P = 10k\Omega$		0.7			0.7		ppm/%
Line Regulation ( $V_{IN} = 13V$ to 33V)		$0^\circ C \leq T_A \leq +70^\circ C$ (Note 2)		0.007	0.012		0.007	0.012	%/V
Load Regulation ( $I_L = 0$ to 8mA)		$0^\circ C \leq T_A \leq +70^\circ C$ (Note 2)		0.006	0.010		0.007	0.012	%/mA

# +5V, +10V Precision Voltage References

REF01/REF02

## ELECTRICAL CHARACTERISTICS—REF01C

( $V_{IN} = +15V$ ,  $T_A = +25^\circ C$ ,  $I_L = 0mA$ , unless otherwise noted.)

PARAMETER	SYMBOL	CONDITIONS	REF01C			UNITS
			MIN	TYP	MAX	
Output Voltage	$V_O$	$I_L = 0mA$	9.90	10.00	10.10	V
Output Adjustment Range	$\Delta V_{trim}$	$R_P = 10k\Omega$	$\pm 2.7$	$\pm 6.0$		%
Output Voltage Noise	$e_{nP-P}$	0.1Hz to 10Hz (Note 1)		25	35	$\mu V_{P-P}$
Line Regulation		$V_{IN} = 13V$ to 30V (Note 2)		0.009	0.015	%/V
Load Regulation (Note 2)		$I_L = 0$ to 8mA		0.006	0.015	%/mA
		$I_L = 0$ to 4mA		0.006	0.015	
Turn-On Settling Time	$t_{ON}$	To $\pm 0.1\%$ of final value		400		$\mu s$
Quiescent Supply Current	$I_{SY}$	No load		1.0	1.6	mA
Load Current	$I_L$	To specified output voltage tolerance	8	21		mA
Sink Current	$I_S$	To specified output voltage tolerance	0.2	0.5		mA
Short-Circuit Current	$I_{SC}$	$V_O = 0V$		30		mA

## ELECTRICAL CHARACTERISTICS—REF01C

( $V_{IN} = +15V$ ,  $T_A = T_{MIN}$  to  $T_{MAX}$ , unless otherwise noted.)

PARAMETER	SYMBOL	CONDITIONS	REF01C			UNITS
			MIN	TYP	MAX	
Output Voltage Change with Temperature	$\Delta V_{OT}$	(Note 3)		0.14	0.45	%
Output Voltage Temperature Coefficient	$TCV_O$	(Note 4)		20	65	ppm/ $^\circ C$
Change in $V_O$ Temperature Coefficient with Output Adjustment		$R_P = 10k\Omega$		0.7		ppm/%
Line Regulation		$V_{IN} = 13V$ to 30V (Note 2)		0.011	0.018	%/V
Load Regulation		$I_L = 0$ to 5mA (Note 2)		0.008	0.018	%/mA

**Note 1:** Guaranteed by design.

**Note 2:** Line and load regulation specifications include the effect of self heating. 100% production tested at  $T_A = +25^\circ C$  and guaranteed by design for  $T_A = T_{MIN}$  to  $T_{MAX}$ , as specified.

**Note 3:**  $\Delta V_{OT}$  is defined as the absolute difference between the maximum output voltage and the minimum output voltage over the specified temperature range expressed as a percentage of 10V. Guaranteed by design.

$$\Delta V_{OT} = \left[ \frac{V_{MAX} - V_{MIN}}{10V} \right] \times 100$$

**Note 4:**  $TCV_O$  is defined as  $\Delta V_{OT}$  divided by the temperature range. Guaranteed by design.

### Output Adjustment

The REF01 trim terminal can be used to adjust the voltage over a 10V  $\pm 600mV$  range. This feature allows the system designer to trim system errors by setting the reference to a voltage other than 10V, including 10.240V for

binary applications (see the *Typical Operating Circuit*).

Adjustment of the output does not significantly affect the temperature performance of the device. The temperature coefficient change is approximately 0.7ppm/ $^\circ C$  for 100mV of output adjustment.

# +5V, +10V Precision Voltage References

## ABSOLUTE MAXIMUM RATINGS—REF02

Input Voltage	
REF02, E, H	40V
REF02C	30V
Continuous Power Dissipation	
Plastic Dip (P) (derate at 5.6mW/°C above +36°C)	500mW
Small Outline (S) (derate at 5.0mW/°C above +55°C)	300mW
Storage Temperature Range	-65°C to +150°C

Operating Temperature Range	
REF02E, REF02H	0°C to +70°C
REF02C (except REF02CESA)	0°C to +70°C
REF02CESA	-40°C to +85°C
Output Short-Circuit Duration (to ground or $V_{IN}$ )	Indefinite
Lead Temperature (soldering, 60s)	+300°C

Stresses beyond those listed under "Absolute Maximum Ratings" may cause permanent damage to the device. These are stress ratings only, and functional operation of the device at these or any other conditions beyond those indicated in the operational sections of the specifications is not implied. Exposure to absolute maximum rating conditions for extended periods may affect device reliability.

## ELECTRICAL CHARACTERISTICS—REF02E/REF02H

( $V_{IN} = +15V$ ,  $T_A = +25^\circ C$ , unless otherwise noted.)

PARAMETER	SYMBOL	CONDITIONS	REF02E			REF02H			UNITS
			MIN	TYP	MAX	MIN	TYP	MAX	
Output Voltage	$V_O$	$I_L = 0$	4.985	5.000	5.015	4.975	5.000	5.025	V
Output Adjustment Range	$\Delta V_{trim}$	$R_P = 10k\Omega$	$\pm 3$	$\pm 6$		$\pm 3$	$\pm 6$		%
Output Voltage Noise	$e_{nP-P}$	0.1Hz to 10Hz (Note 5)		10	15		10	15	$\mu V_{P-P}$
Line Regulation		$V_{IN} = 8V$ to 33V (Note 6)		0.006	0.010		0.006	0.010	%/V
Load Regulation		$I_L = 0$ to 10mA (Note 6)		0.005	0.010		0.006	0.010	%/mA
Turn-On Settling Time	$t_{ON}$	To $\pm 0.1\%$ of final value		230			230		$\mu s$
Quiescent Supply Current	$I_{SY}$	No load		1.0	1.4		1.0	1.4	mA
Load Current	$I_L$	To specified output voltage tolerance	10	21		10	21		mA
Sink Current	$I_S$	To specified output voltage tolerance	0.3	0.5		0.3	0.5		mA
Short-Circuit Current	$I_{SC}$	$V_O = 0V$		30			30		mA
Temperature Voltage Output	$V_T$	(Note 7)		630			630		mV

## ELECTRICAL CHARACTERISTICS—REF02E/REF02H

( $V_{IN} = +15V$ ,  $0^\circ C \leq T_A \leq +70^\circ C$  for REF02E and REF02H,  $I_L = 0mA$ , unless otherwise noted.)

PARAMETER	SYMBOL	CONDITIONS	REF02E			REF02H			UNITS
			MIN	TYP	MAX	MIN	TYP	MAX	
Output Voltage Change with Temperature	$\Delta V_{OT}$	$0^\circ C \leq T_A \leq +70^\circ C$ (Note 8)		0.02	0.06		0.07	0.17	%
Output Voltage Temperature Coefficient	$TCV_O$	(Note 9)		3	8.5		10	25	ppm/°C
Change in $V_O$ Temperature Coefficient with Output Adjustment		$R_P = 10k\Omega$		0.7			0.7		ppm/%
Line Regulation ( $V_{IN} = 8V$ to 33V)		$0^\circ C \leq T_A \leq +70^\circ C$ (Note 6)		0.007	0.012		0.007	0.012	%/V
Load Regulation ( $I_L = 0$ to 8mA)		$0^\circ C \leq T_A \leq +70^\circ C$ (Note 6)		0.006	0.010		0.007	0.012	%/mA

# +5V, +10V Precision Voltage References

REF01/REF02

## ELECTRICAL CHARACTERISTICS—REF02E/REF02H (continued)

( $V_{IN} = +15V$ ,  $0^{\circ}C \leq T_A \leq +70^{\circ}C$  for REF02E and REF02H,  $I_L = 0mA$ , unless otherwise noted.)

PARAMETER	SYMBOL	CONDITIONS	REF02E			REF02H			UNITS
			MIN	TYP	MAX	MIN	TYP	MAX	
Temperature Voltage Output Temperature Coefficient	TCVT	(Note 7)	2.1			2.1			mV/°C

## ELECTRICAL CHARACTERISTICS—REF02C

( $V_{IN} = +15V$ ,  $T_A = +25^{\circ}C$ , unless otherwise noted.)

PARAMETER	SYMBOL	CONDITIONS	REF02C			UNITS
			MIN	TYP	MAX	
Output Voltage	$V_O$	$I_L = 0mA$	4.950	5.000	5.050	V
Output Adjustment Range	$\Delta V_{trim}$	$R_P = 10k\Omega$	$\pm 2.7$	$\pm 6.0$		%
Output Voltage Noise	enP-P	0.1Hz to 10Hz (Note 5)		12	18	$\mu V_{P-P}$
Line Regulation		$V_{IN} = 8V$ to 30V (Note 6)		0.009	0.015	%/V
Load Regulation (Note 6)		$I_L = 0$ to 8mA		0.006	0.015	%/mA
		$I_L = 0$ to 4mA				
Turn-On Settling Time	tON	To $\pm 0.1\%$ of final value		230		$\mu s$
Quiescent Supply Current	ISY	No load		1.0	1.6	mA
Load Current	$I_L$	To specified output voltage tolerance	8	21		mA
Sink Current	IS	To specified output voltage tolerance	0.2	0.5		mA
Short-Circuit Current	ISC	$V_O = 0V$		30		mA
Temperature Voltage Output	VT	(Note 7)		630		mV

## ELECTRICAL CHARACTERISTICS—REF02C

( $V_{IN} = +15V$ ,  $T_A = T_{MIN}$  to  $T_{MAX}$ ,  $I_L = 0mA$ , unless otherwise noted.)

PARAMETER	SYMBOL	CONDITIONS	REF02C			UNITS
			MIN	TYP	MAX	
Output Voltage Change with Temperature	$\Delta V_{OT}$	(Note 8)		0.14	0.45	%
Output Voltage Temperature Coefficient	TCVO	(Note 9)		20	65	ppm/°C
Change in $V_O$ Temperature Coefficient with Output Adjustment		$R_P = 10k\Omega$		0.7		ppm/%
Line Regulation		$V_{IN} = 8V$ to 30V (Note 6)		0.011	0.018	%/V
Load Regulation		$I_L = 0$ to 5mA (Note 6)		0.008	0.018	%/mA
Temperature Voltage Output Temperature Coefficient	TCVT	(Note 7)		2.1		mV/°C

# +5V, +10V Precision Voltage References

## ELECTRICAL CHARACTERISTICS—REF02 (continued)

( $V_{IN} = +15V$ ,  $T_A = T_{MIN}$  to  $T_{MAX}$ ,  $I_L = 0mA$ , unless otherwise noted.)

**Note 5:** Guaranteed by design.

**Note 6:** Line and load regulation specifications include the effect of self heating. 100% production tested at  $T_A = +25^\circ C$  and guaranteed by design for  $T_A = T_{MIN}$  to  $T_{MAX}$ , as specified.

**Note 7:** Limit current in or out of pin 3 to 50nA and capacitance on pin 3 to 30pF.

**Note 8:**  $\Delta V_{OT}$  is defined as the absolute difference between the maximum output voltage and the minimum output voltage over the specified temperature range expressed as a percentage of 5V. Guaranteed by design.

$$\Delta V_{OT} = \left[ \frac{V_{MAX} - V_{MIN}}{5V} \right] \times 100$$

**Note 9:**  $TCV_O$  is defined as  $\Delta V_{OT}$  divided by the temperature range. Guaranteed by design.

### Output Adjustment

The REF02 trim terminal can be used to adjust the output voltage over a  $5V \pm 300mV$  range. This feature allows the system designer to trim system errors by setting the reference to a voltage other than 5V (refer to the *Typical Operating Circuit*).

Adjustment of the output does not significantly affect the temperature performance of the device. Typically, the temperature coefficient change is  $0.7ppm/^\circ C$  for 100mV of output adjustment.

### Temperature Voltage Output

The REF02 provides a temperature-dependent output voltage on the TEMP pin. This voltage is proportional to the absolute temperature, and has a scale factor of approximately  $2.1mV/^\circ C$  (Figure 1).

$$\text{Output Voltage} = 2.1(T + 273)mV$$

where  $T = \text{Temperature in } ^\circ C$ .

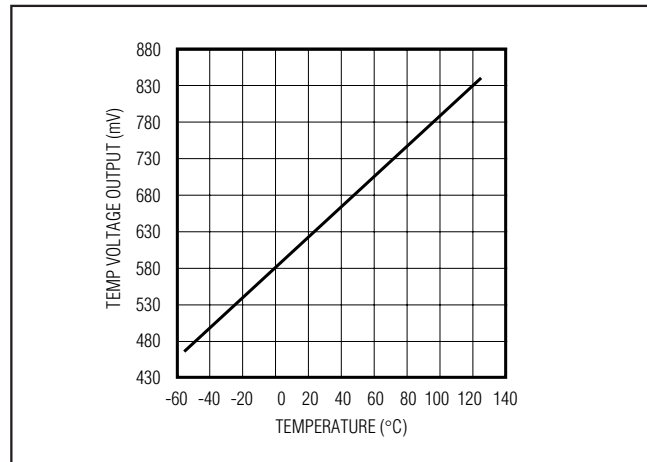

Figure 1. REF02 Temperature/Voltage Output vs. Temperature

# +5V, +10V Precision Voltage References

## Typical Operating Characteristics

( $T_A = +25^\circ\text{C}$ , unless otherwise noted.)

REF01/REF02

**LINE REGULATION vs. FREQUENCY**

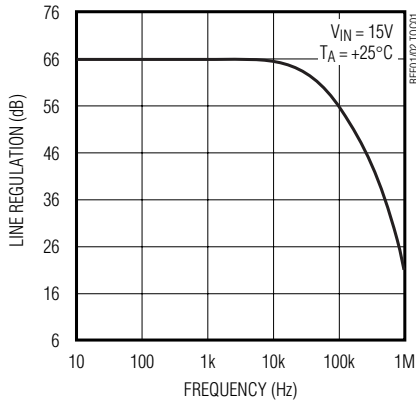

**REF01 OUTPUT WIDEBAND NOISE vs. BANDWIDTH (0.1Hz TO FREQUENCY INDICATED)**

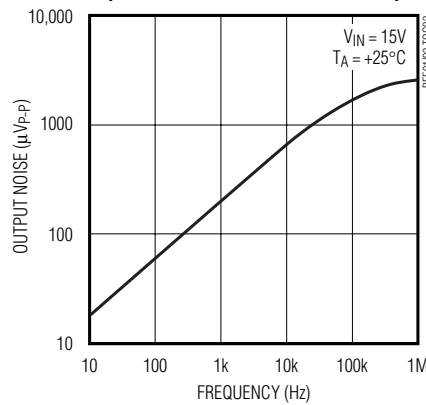

**REF02 OUTPUT WIDEBAND NOISE vs. BANDWIDTH (0.1Hz TO FREQUENCY INDICATED)**

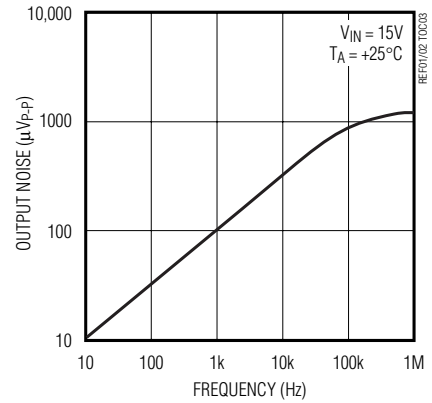

**MAXIMUM LOAD CURRENT vs. INPUT VOLTAGE**

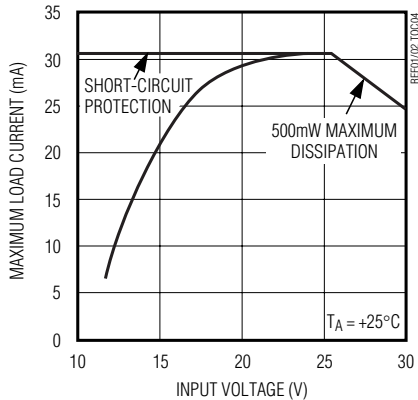

**NORMALIZED LOAD REGULATION ( $\Delta I_L = 10\text{mA}$ ) vs. TEMPERATURE**

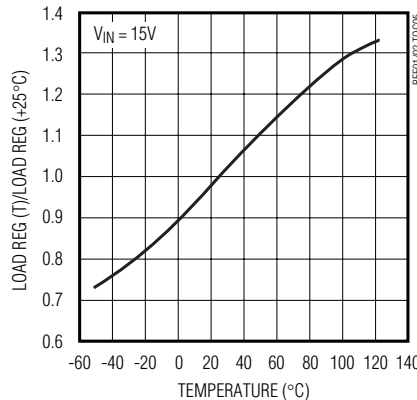

**NORMALIZED LINE REGULATION vs. TEMPERATURE**

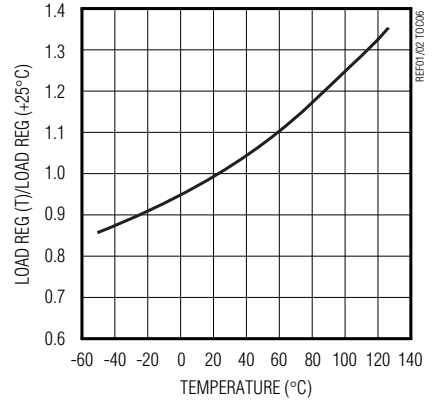

**MAXIMUM LOAD CURRENT vs. TEMPERATURE**

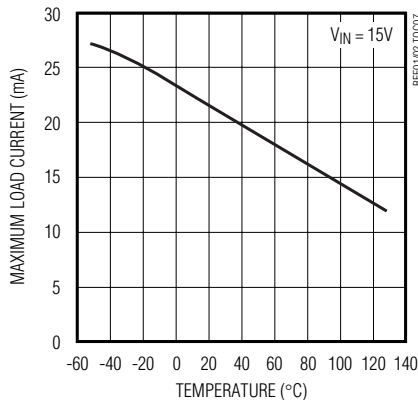

**QUIESCENT CURRENT vs. TEMPERATURE**

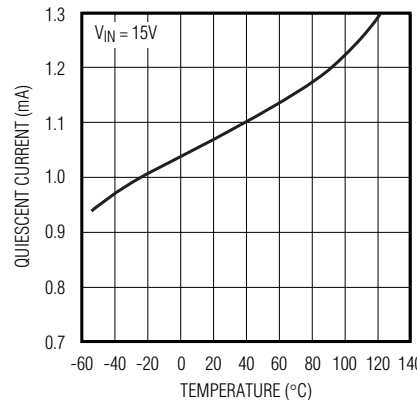

**OUTPUT CHANGE DUE TO THERMAL SHOCK**

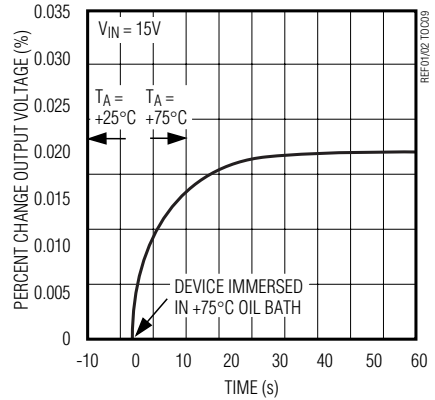

# +5V, +10V Precision Voltage References

## Typical Applications

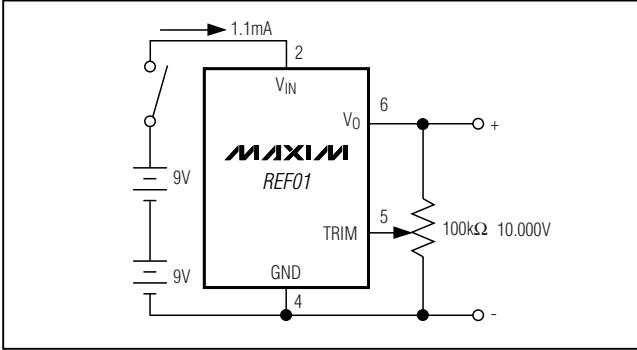

Figure 2. Precision Calibration Standard

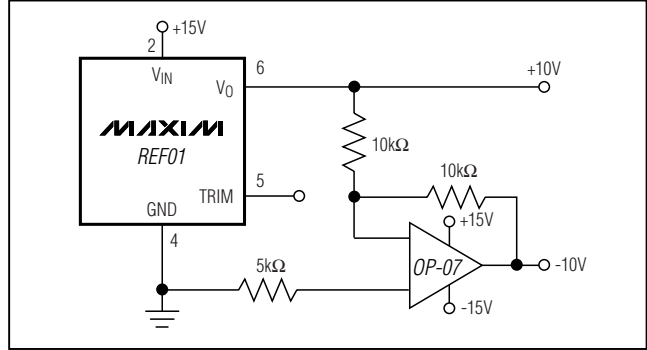

Figure 3. ±10V Reference

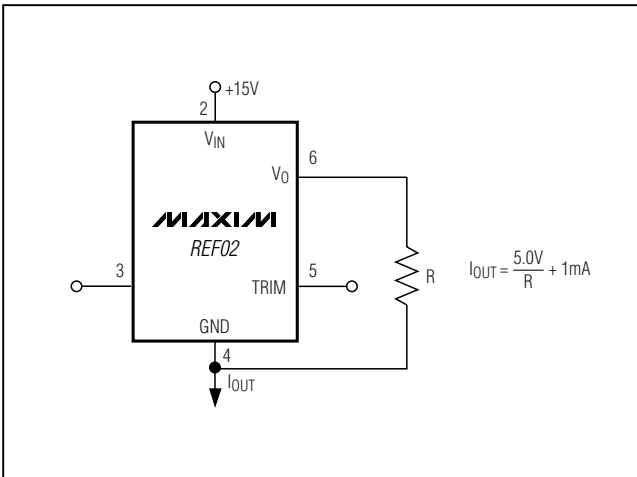

Figure 4. Current Source

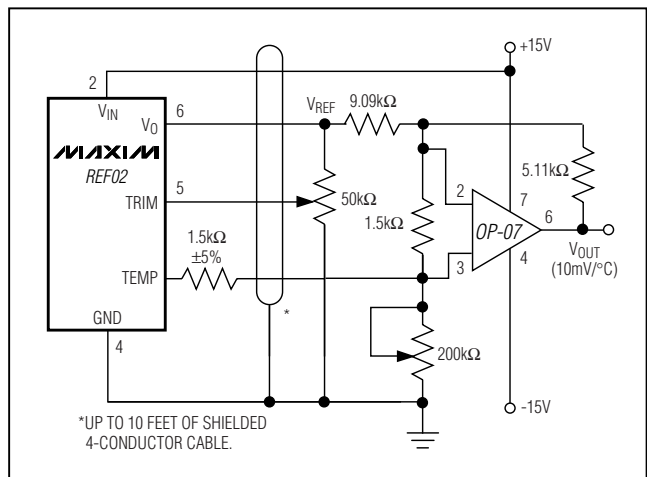

Figure 5. Precision Temperature Transducer with Remote Sensor



# +5V, +10V Precision Voltage References

## Pin Configurations

**REF01/REF02**

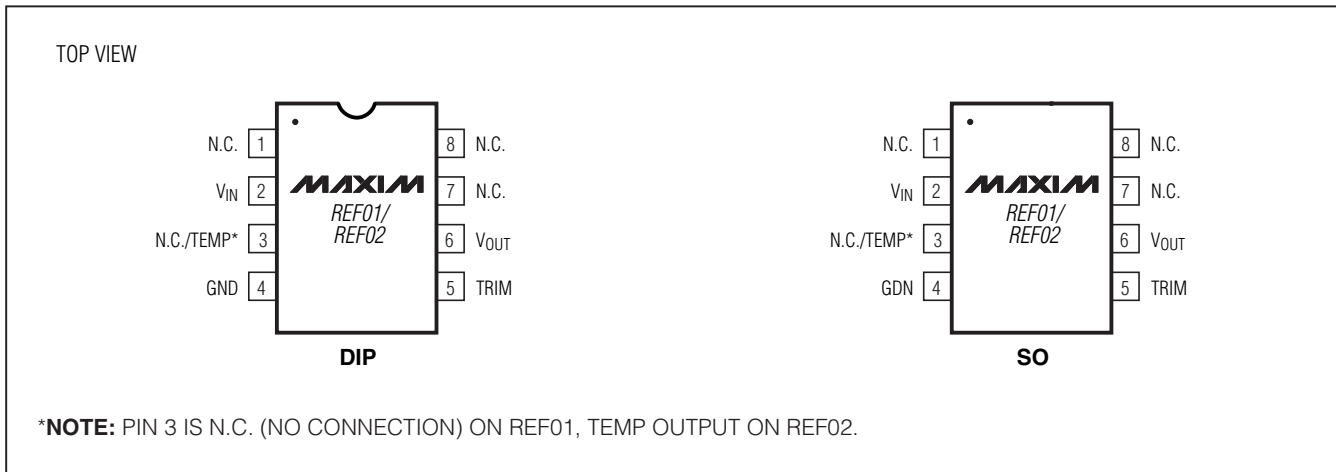

## Ordering Information (continued)

PART	TEMP RANGE	MAX TEMPCO (ppm/°C)	INITIAL ERROR (mV)	PIN-PACKAGE	PKG CODE
REF02EP	0°C to +70°C	8.5	±15	8 Plastic DIP	P8-2
REF02EP+	0°C to +70°C	8.5	±15	8 Plastic DIP	P8-2
REF02HP	0°C to +70°C	25	±25	8 Plastic DIP	P8-2
REF02HP+	0°C to +70°C	25	±25	8 Plastic DIP	P8-2
REF02HSA	0°C to +70°C	25	±25	8 SO	S8-2
REF02HSA+	0°C to +70°C	25	±25	8 SO	S8-2
REF02CP	0°C to +70°C	65	±50	8 Plastic DIP	P8-2
REF02CP+	0°C to +70°C	65	±50	8 Plastic DIP	P8-2
REF02CSA	0°C to +70°C	65	±50	8 SO	S8-2
REF02CSA+	0°C to +70°C	65	±50	8 SO	S8-2
REF02CESA	-40°C to +85°C	65	±50	8 SO	S8-2
REF02CESA+	-40°C to +85°C	65	±50	8 SO	S8-2

+Denotes a lead-free package.

## Revision History

Pages changed at Rev 7: 1, 9

## Package Information

For the latest package outline information, go to [www.maxim-ic.com/packages](http://www.maxim-ic.com/packages).

Maxim cannot assume responsibility for use of any circuitry other than circuitry entirely embodied in a Maxim product. No circuit patent licenses are implied. Maxim reserves the right to change the circuitry and specifications without notice at any time.

**Maxim Integrated Products, 120 San Gabriel Drive, Sunnyvale, CA 94086 408-737-7600** 9

## X-ON Electronics

Largest Supplier of Electrical and Electronic Components

*Click to view similar products for [Voltage References](#) category:*

*Click to view products by [Maxim](#) manufacturer:*

Other Similar products are found below :

[REF01J/883](#) [5962-8686103XC](#) [NCV431BVDMR2G](#) [LT6654AMPS6-2.048#TRMPBF](#) [SCV431AIDMR2G](#) [LT1019AIS8-2.5](#)  
[LT6654AMPS6-3.3#TRM](#) [SC431ILPRAG](#) [AP432AQG-7](#) [LM4040B25QFTA](#) [NJM2823F-TE1](#) [TL431-A](#) [MCP1502T-18E/CHY](#) [MCP1502T-40E/CHY](#) [TL4050B25QDBZR](#) [TL431ACZ](#) [KA431SLMF2TF](#) [KA431SMF2TF](#) [KA431SMFTF](#) [LM4040QCEM3-3.0/NOPB](#)  
[LM4041C12ILPR](#) [LM4120AIM5-2.5/NOP](#) [LM431SCCMFX](#) [TS3330AQPR](#) [REF5040MDREP](#) [LM285BXM3-1.2/NOPB](#) [LM385BM-2.5/NOPB](#) [LM4040AIM3-10.0](#) [LM4040BIM3-4.1](#) [LM4040CIM3-10.0](#) [LM4040CIM3X-2.0/NOPB](#) [LM4041BSD-122GT3](#) [LM4041QDIM3-ADJ/NO](#) [LM4050QAEM3X4.1/NOPB](#) [LM4051BIM3-ADJ/NOPB](#) [LM4051CIM3X-1.2/NOPB](#) [LM4128CMF-1.8/NOPB](#) [LM4132DMF-1.8/NOPB](#) [LM4132EMF-1.8/NOPB](#) [LM4132EMF-2.0/NOPB](#) [LM4140CCMX-1.2/NOPB](#) [LM431CIM](#) [LM385BD-2.5R2G](#) [LM385M-2.5/NOPB](#) [LM4030AMF-4.096/NOPB](#) [LM4040D30ILPR](#) [LM4051CIM3X-ADJ/NOPB](#) [AP432YG-13](#) [AS431ANTR-G1](#) [AS431BZTR-E1](#)