

## General Description

The iML8683 is a Three Terminal Current Controller (TTCC) for regulating the current flowing through an LED string.

The application of the iML8683 is configured in parallel with an LED string. The iML8683 can work as voltage controlled current source, current regulator, or cut-off. It is suitable for the applications adopting periodical AC voltage source.

The PCB layout is also very flexible to meet various shape requirements. It is especially suitable for replacing incandescent light bulb and linear type fluorescent lamp.

## Features

### System

- All solid state components.
- No electrolytic capacitor required.
- Compact size to minimize mechanical cost.
- Driver-on-board and chip-on-board available which minimize process flow and assembly cost.
- High PF and Low THD performance.
- High efficiency achieved.
- Flexible PCB layout style.
- Wide range of LED forward voltage selection.
- Distributed heat to several chips.
- TRIAC dimmable.

### Chip

- 88V input sustaining voltage.
- <3V dropout voltage for up to 150mA regulating current

## Typical Application Circuit

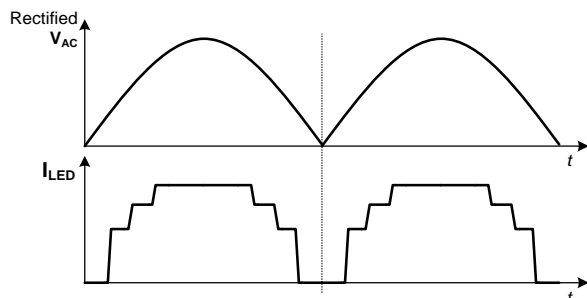
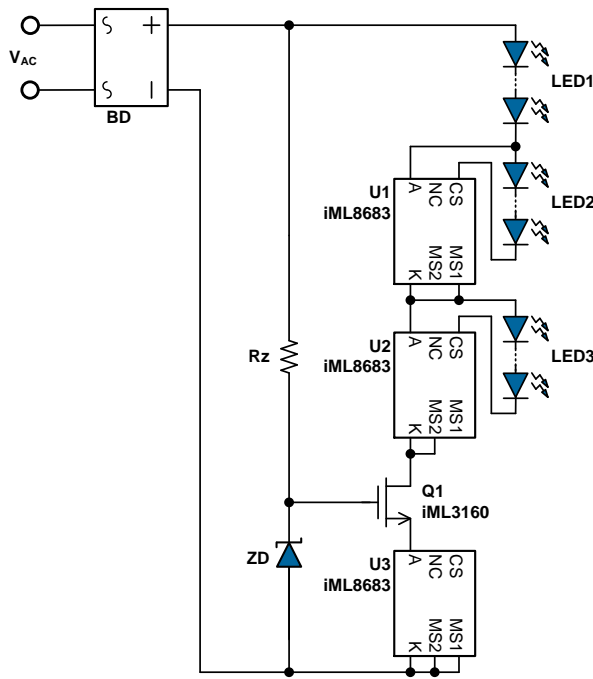

## Applications

- AC LED lighting engine.
- LED light bulb.
- LED light tube.
- LED down-light and ceiling light
- LED flat panel light

## Pin Diagram (Top View)

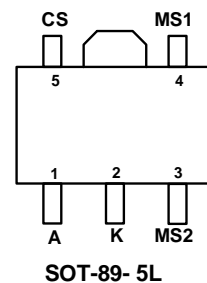
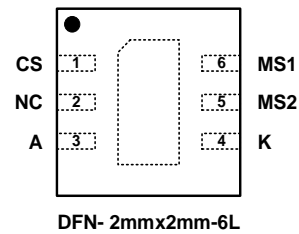

## Ordering Information

Package Type: DFN – 2mm x 2mm – 6L (Halogen Free)

Part Number	Tape and Reel	1 <sup>st</sup> Line Marking	Regulating Current (mA) (Mode 0, MS1 and MS2 connected to pin K)
iML8683NL-C1	iML8683NL-C1-TR	i83C1	40
iML8683NL-C2	iML8683NL-C2-TR	i83C2	66
iML8683NL-C3	iML8683NL-C3-TR	i83C3	52
iML8683NL-D1	iML8683NL-D1-TR	i83D1	80
iML8683NL-D2	iML8683NL-D2-TR	i83D2	130
iML8683NL-D3	iML8683NL-D3-TR	i83D3	104
iML8683NL-ADJ	iML8683NL-ADJ-TR	i83AD	Determined by external resistor only

Package Type: SOT – 89 – 5L (Halogen Free)

Part Number	Tape and Reel	1 <sup>st</sup> Line Marking	Regulating Current (mA) (Mode 0, MS1 and MS2 connected to pin K)
iML8683BP-C1	iML8683BP-C1-TR	i8683C1	40
iML8683BP-C2	iML8683BP-C2-TR	i8683C2	66
iML8683BP-C3	iML8683BP-C3-TR	i8683C3	52
iML8683BP-D1	iML8683BP-D1-TR	i8683D1	80
iML8683BP-D2	iML8683BP-D2-TR	i8683D2	130
iML8683BP-D3	iML8683BP-D3-TR	i8683D3	104
iML8683BP-ADJ	iML8683BP-ADJ-TR	i8683AD	Determined by external resistor only

Dice

Part Number	Regulating Current (mA) (Mode 0, MS1 and MS2 connected to pin K)
iML8683BZ-C1	40
iML8683BZ-C2	66
iML8683BZ-C3	52
iML8683BZ-D1	80
iML8683BZ-D2	130
iML8683BZ-D3	104
iML8683BZ-ADJ	Determined by external resistor only

### Block Diagram

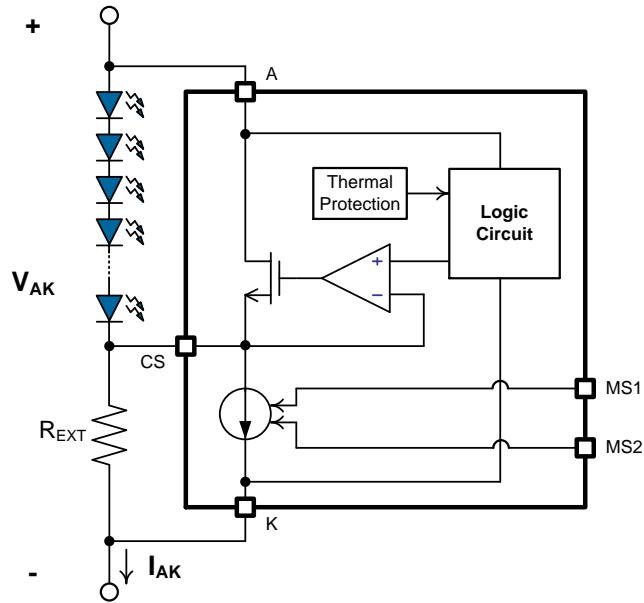

### I-V Curve

Cx / Dx Options

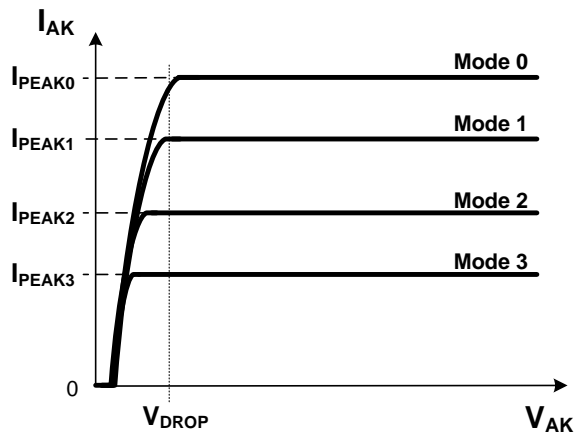

ADJ Options

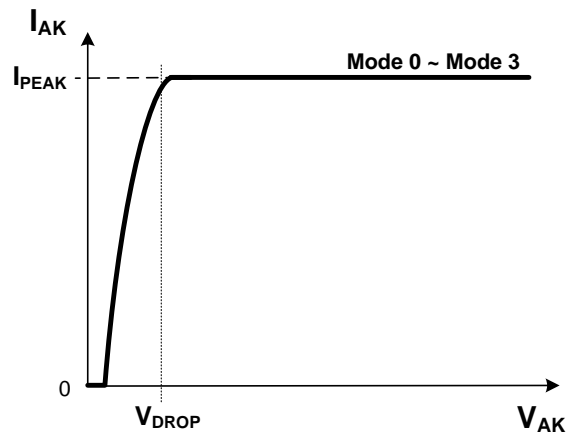

## Pin Descriptions

Pin Name	Pin Number		Pin Function
	DFN	SOT-89	
CS	1	5	Current sense pin. Connected to negative end of LED string.
A	3	1	Regulating current input pin. Connected to positive end of LED string.
K	4	2	Regulating current output pin.
MS2	5	3	Mode selection pin 2. Floating or connecting to pin K only.
MS1	6	4	Mode selection pin 1. Floating or connecting to pin K only.
NC	2	-	No Connection
Exposed Thermal Pad			Exposed thermal pad of the chip. Use this pin to enhance the power dissipation ability. The thermal conductivity will be improved if a copper foil on PCB is soldered with the thermal pad. It is recommended to connect the thermal pad to pin K.

## Absolute Maximum Ratings

**Caution:** Values beyond absolute ratings can cause the device to be prematurely damaged.

Absolute maximum ratings are stress ratings only and functional device operation is not guaranteed.

Sustaining Voltage	A to K	-0.3V ~ 88V
	CS, MS1, MS2 to K	-0.3V ~ 1V
Regulating Current		150mA
Maximum Operating Junction Temperature, $T_J$		165°C
Operating Temperature, $T_{opr}$		-40°C to 110°C
Storage Temperature Range		-55°C to 150°C
Lead Temperature (Soldering, 10 seconds)		260°C

### Note:

- 1). All voltages are with respect to Ground. Currents are positive into, negative out of the specified terminal.
- 2). All parameters having Min/Max specifications are guaranteed. Typical values are for reference purpose only.
- 3). Unless otherwise noted, all tests are pulsed tests at the specified temperature, therefore:  $T_J = T_C = T_A$ .

## Recommended Operating Conditions

Parameter	Symbol	Min	Typ	Max	Unit
Regulating Current (with Adequate Heat Sinking) <sup>*Note</sup>	$I_{AK}$			130	mA
Input Voltage <sup>*Note</sup>	$V_{AK}$	3		80	V
Maximum Junction Temperature	$T_J$			150	°C
Operating Free-Air Temperature Range	$T_A$	-30		100	°C

Note: Due to thermal dissipation consideration, the maximum LED Vf in parallel should decrease with the regulating current.

## Electrical Characteristics

Unless otherwise noted, typical values are @  $T_A = 25^\circ\text{C}$ .

Parameter	Symbol	Test Conditions	Min	Typ	Max	Unit	
Peak Regulating Current <small>*Note 1,2</small>	$I_{PEAK0}$	$V_{AK}=5\text{V}$ , Mode 0 (MS1/ MS2 connected to K)	Option C1	38.4	40	41.6	mA
			Option C2	63.4	66	68.6	
			Option C3	49.9	52	54.1	
			Option D1	76.8	80	83.2	
			Option D2	124.8	130	135.2	
			Option D3	99.8	104	108.2	
Current Ratio of Mode Selection <small>*Note 1</small>	$I_{PEAK0}/I_{PEAK0}$	Option C1/C2/C3/D1/D2/D3, Mode 0, $V_{AK}=5\text{V}$ (MS1/ MS2 connected to K)		100		%	
	$I_{PEAK1}/I_{PEAK0}$	Option C1/C2/C3/D1/D2/D3, Mode 1, $V_{AK}=5\text{V}$ (MS1 open, MS2 connected to K)	75	80	85		
	$I_{PEAK2}/I_{PEAK0}$	Option C1/C2/C3/D1/D2/D3, Mode 2, $V_{AK}=5\text{V}$ (MS2 open, MS1 connected to K)	50	55	60		
	$I_{PEAK3}/I_{PEAK0}$	Option C1/C2/C3/D1/D2/D3, Mode 3, $V_{AK}=5\text{V}$ (MS1/ MS2 open)	32	35	38		
Regulating Current Line Regulation <small>*Note 3</small>	$\Delta I_{LR}/I_{PEAKx}$ (x=0~3)	Option C1/C2/C3/D1/D2/D3, Mode 1~3, $V_{AK}=5\text{V}$ and 40V		$\pm 1$	$\pm 2$	%	
		Option C1/C2/C3/D1/D2/D3, Mode 0, $V_{AK}=5\text{V}$ and 40V	-4	-8	-15		
CS Pin Voltage	$V_{CS}$	Option ADJ, Mode 0, $V_{AK}=5\text{V}$ , with 1K $\Omega$ external resistor between CS and K	0.26	0.27	0.28	V	
CS Pin Voltage Line Regulation <small>*Note 4</small>	$\Delta V_{LR}/V_{CS}$	Option ADJ, Mode 1~3, $V_{AK}=5\text{V}$ and 40V with 1K $\Omega$ external resistor between CS and K		$\pm 1$	$\pm 2$	%	
		Option ADJ, Mode 0, $V_{AK}=5\text{V}$ and 40V with 1K $\Omega$ external resistor between CS and K	-4	-8	-15	%	
Dropout Voltage <small>*Note 5</small>	$V_{DROP}$	Mode 0 (MS1/ MS2 connected to K)		2.8	3.8	V	
Thermal Protection Trip Temperature <small>*Note 6</small>	$T_{TP}$	When $T_J$ is higher than $T_{TP}$ , the peak regulating current decreases to $I_{TP}$ linearly.	120	130		$^\circ\text{C}$	
Thermal Protection Mode Regulating Current	$I_{TP}/I_{PEAKx}$ (x=0~3)	$T_J = 175^\circ\text{C}$		50		%	

Three Terminal Current Controller

Note 1: For ADJ option, the regulating current is determined by an external resistor, R<sub>EXT</sub>, connected between the CS pin and the K pin. The mode selection function will not change the current ratio of option ADJ. To activate the line regulation function, the chip (U3) connected in series with the LED string should be set in Mode 0 (MS1 and MS2 connected to pin K). The regulating current will be:

$$I_{PEAK} = 0.27/R_{EXT}$$

And the maximum regulating current of second step (ex: U2 in Mode 1) should not exceed 80% of the top level (ex: U3 in Mode 0), otherwise the circuit operation might become abnormal when OTP function is activated. It is strongly recommended to set at 75%.

Note 2: The user can add an external resistor R<sub>EXT</sub> between the CS pin and the K pin of U3 (Mode 0, serial connected to the LED string) to increase the regulating current of option C1, C2, C3, D1, D2 and D3, as shown in below. For U1 ~ U2 (Mode 1 ~ Mode 3, parallel connected to the LED string), adding an external resistor R<sub>EXT</sub> between the CS pin and the K pin may cause abnormal operation and chip damage.

For option C1/ C2/ C3, the regulating current variation  $\Delta I_{PEAK}/I_{PEAK} = 6.25/R_{EXT}$ .

For option D1/ D2/ D3, the regulating current variation  $\Delta I_{PEAK}/I_{PEAK} = 3.13/R_{EXT}$ .

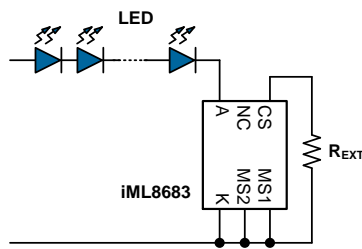

	U3 (Mode 0) regulating current	
	Without external resistor	With 100Ω external resistor
Option C1	40	42.5
Option C2	66	70.1
Option C3	52	55.3
Option D1	80	82.5
Option D2	132	136.1
Option D3	104	107.3

Note 3: The Regulating Current Line Regulation is defined as:

$$\text{For Mode 1~3: } \Delta I_{LR}/I_{PEAKx} = \frac{I_{AK}(V_{AK}=40V) - I_{AK}(V_{AK}=5V)}{I_{AK}(V_{AK}=5V)}, \quad x=1\sim3$$

$$\text{For Mode 0: } \Delta I_{LR}/I_{PEAK0} = \frac{I_{AK}(V_{AK}=40V) - I_{AK}(V_{AK}=5V)}{I_{AK}(V_{AK}=5V)}$$

Note 4: The CS Pin Voltage Line Regulation is defined as:

$$\text{For Mode 1~3: } \Delta V_{LR}/V_{CS} = \frac{V_{CS}(V_{AK}=40V) - V_{CS}(V_{AK}=5V)}{V_{CS}(V_{AK}=5V)}$$

$$\text{For Mode 0: } \Delta V_{LR}/V_{CS} = \frac{V_{CS}(V_{AK}=40V) - V_{CS}(V_{AK}=5V)}{V_{CS}(V_{AK}=5V)}$$

Note 5: Dropout voltage = V<sub>AK</sub> @ 90% × (I<sub>PEAK0</sub> @ V<sub>AK</sub> = 5V)

Note 6: When T<sub>J</sub> > T<sub>TP</sub>, the peak regulating current decreases linearly to around 50% at 175°C.

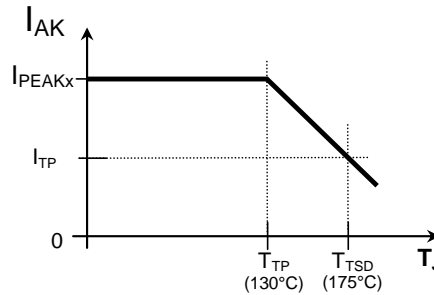

## Application Circuit

### (1) 220V<sub>AC</sub>/ 10W LED Light Engine

- 3 steps, PF=0.98, THD=16%
- To pass 1KV surge test, Q1 can be changed to 800V NMOS.

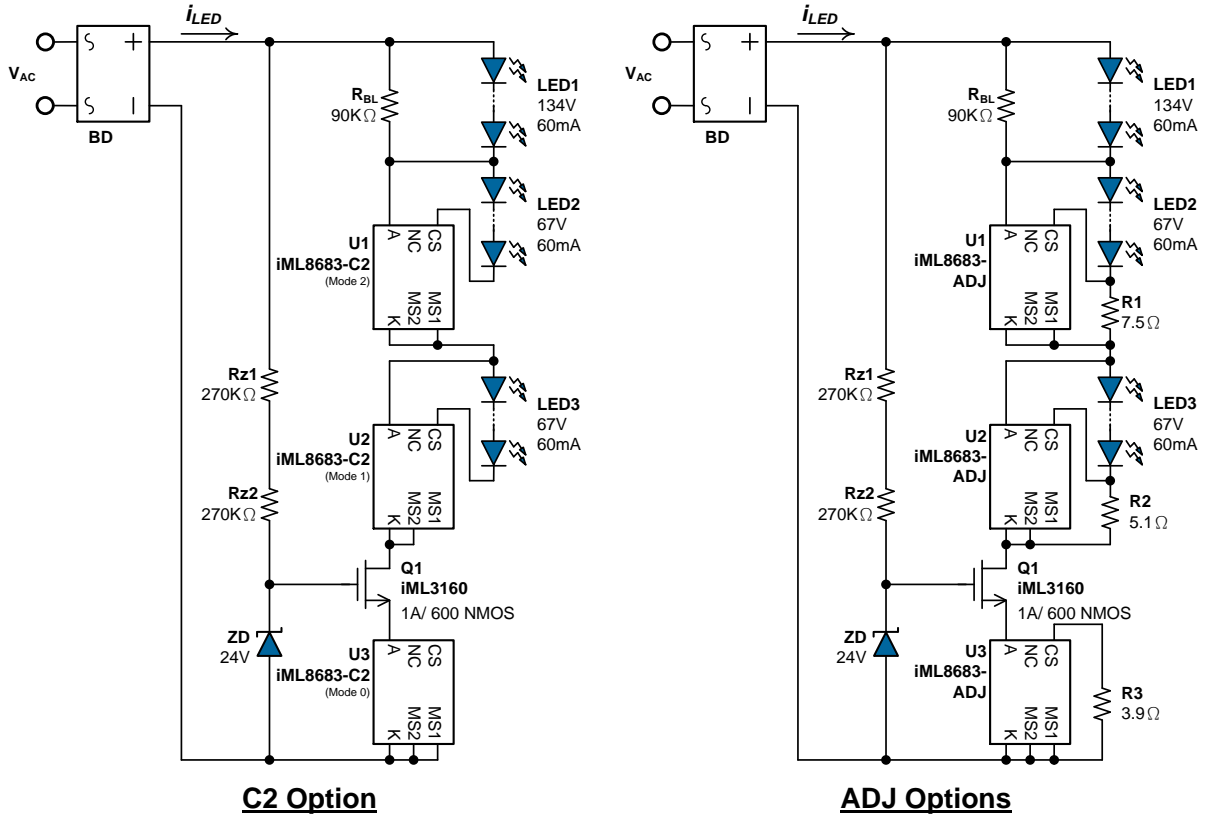

**(2) 10W LED Light Engine**

- 3 steps, PF=0.98, THD=16%
- To pass 1KV surge test, Q1 can be changed to 800V NMOS.

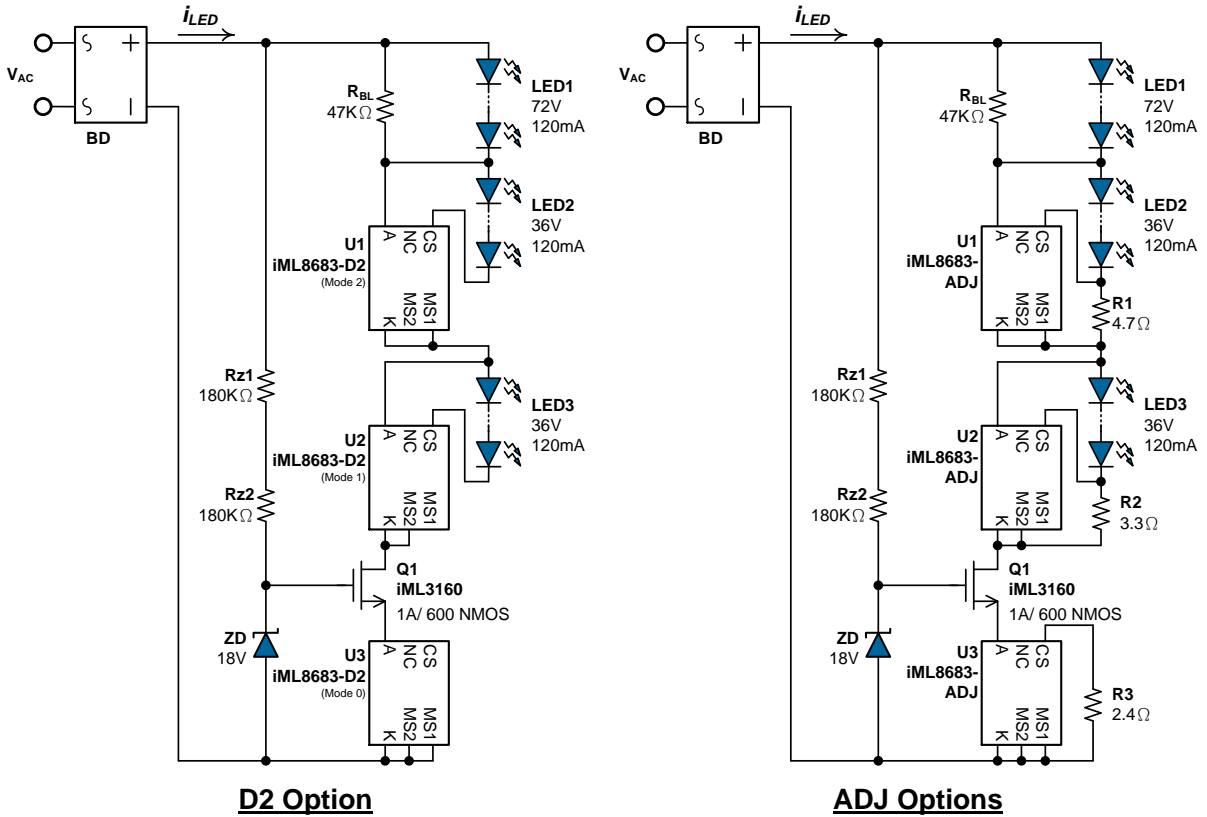



**(3) 7W Low Cost LED Light Engine**

- 2 steps, PF=0.95, THD=28%

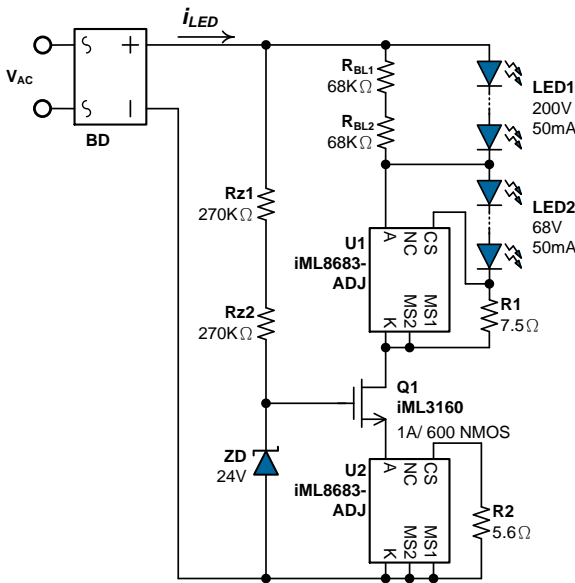

**220VAC/ ADJ Options**

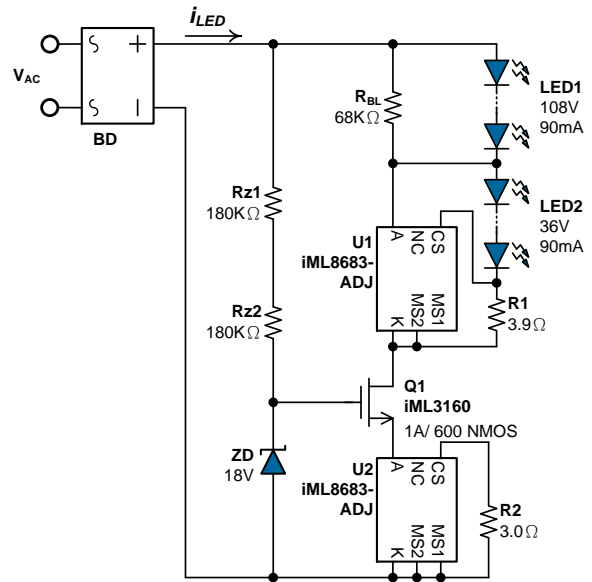

**120VAC/ ADJ Options**

**(4) Low Flicker Solution**

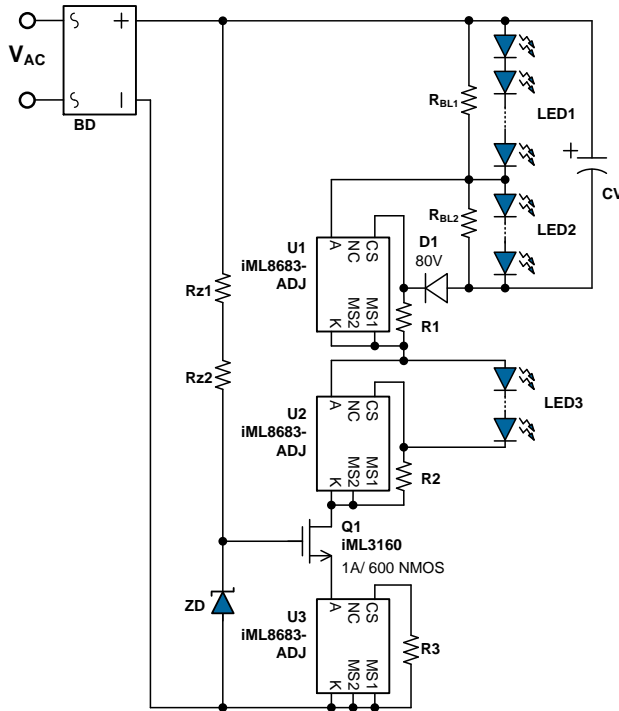

**3-Step/ ADJ Options**

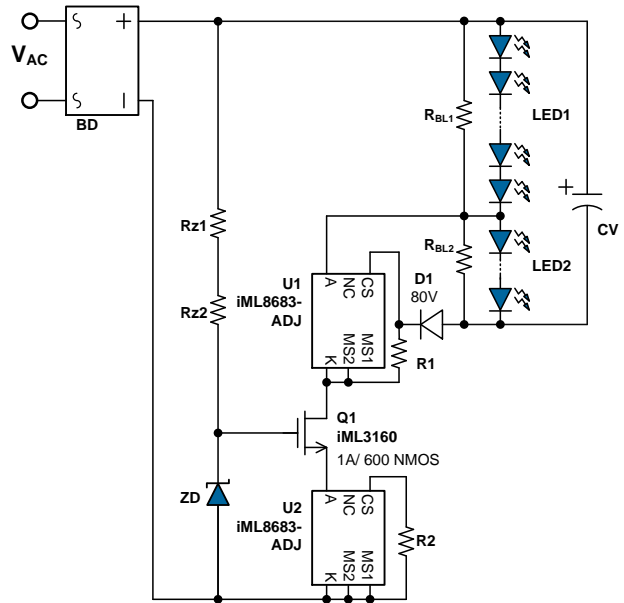

**2-Step/ ADJ Options**

**Package Information**

DFN– 2mmx2mm– 6L

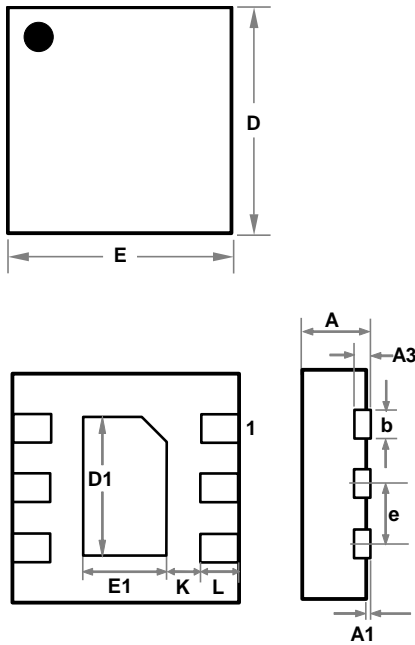

SYMBOLS	MIN.	NOM.	MAX.
A	0.70	0.75	0.80
A1	0.00	0.02	0.05
A3	-	0.20	-
b	0.20	0.30	0.35
D	-	2.00	-
D1	-	1.20	-
E	-	2.00	-
E1	-	0.70	-
e	-	0.65	-
K	0.20	-	-
L	-	0.30	-

UNIT: MILLIMETERS

**Footprint Suggestion**

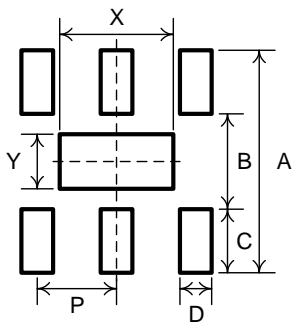

SYMBOLS	Footprint Dimension
A	2.80
B	1.20
C	0.80
D	0.35
P	0.65
X	1.40
Y	0.70

$\theta_{JA}$	103 °C / W
---------------	------------

**SOT-89-5L**

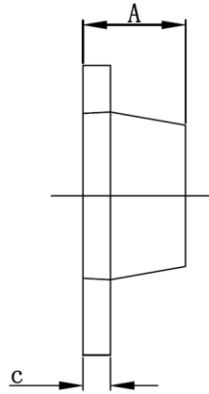
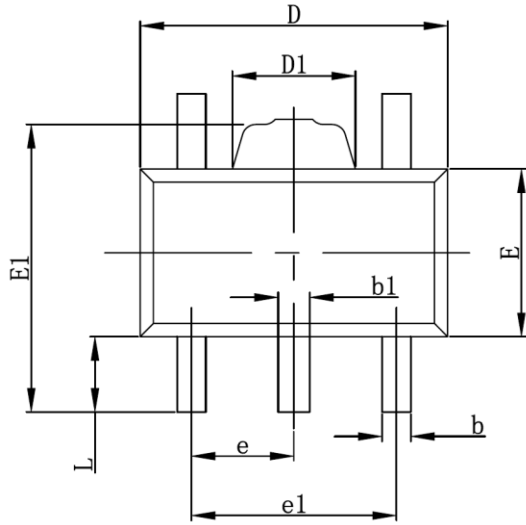

SYMBOLS	MIN.	MAX.
A	1.40	1.60
b	0.32	0.52
b1	0.36	0.56
c	0.35	0.44
D	4.40	4.60
D1	1.40	1.80
E	2.30	2.60
E1	3.94	4.25
e	1.50 TYP	
e1	2.90	3.10
L	0.90	1.10

UNIT: MILLIMETERS

**Footprint Suggestion**

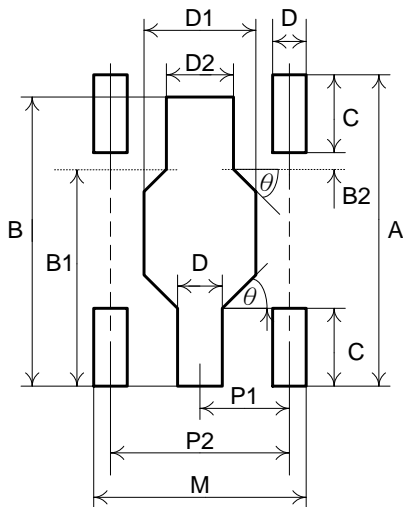

SYMBOLS	Footprint Dimension
A	5.20
B	4.80
B1	3.60
B2	0.25
C	1.35
D	0.70
D1	1.90
D2	1.30
M	3.70
P1	1.50
P2	3.00
$\theta$	45°

UNIT: MILLIMETERS

$\theta_{JA}$	127.5 °C / W
---------------	--------------

## Records of Revisions

Rev.	Date	Page	Description
1.0	Feb. 7, 2014	All	First release.
1.1	Mar. 6, 2014	1, 2, 3, 11	Remove package types of TO-252.
1.2	Nov. 21, 2014	3	Update the Block Diagram and I-V Curve.
		5, 6	Update the $T_{TP}$ Range and Notes.
		7, 8, 9	Update the Application Circuits.
		10, 11	Update the Package Dimension and Footprint Suggestion.
		12	Add Records of Revision

## X-ON Electronics

Largest Supplier of Electrical and Electronic Components

*Click to view similar products for [Motor/Motion/Ignition Controllers & Drivers](#) category:*

*Click to view products by [MaxLinear](#) manufacturer:*

Other Similar products are found below :

[FSB50550TB2](#) [FSBF15CH60BTH](#) [MSVGW45-14-2](#) [MSVGW54-14-3](#) [MSVGW54-14-5](#) [NTE7043](#) [LA6565VR-TLM-E](#) [LB11650-E](#)  
[LB1837M-TLM-E](#) [LB1845DAZ-XE](#) [LC898300XA-MH](#) [SS30-TE-L-E](#) [26700](#) [LV8281VR-TLM-H](#) [BA5839FP-E2](#) [IRAM236-1067A](#)  
[LA6584JA-AH](#) [LB11847L-E](#) [NCV70501DW002R2G](#) [STK672-630CN-E](#) [TND315S-TL-2H](#) [FNA23060](#) [FSB50250AB](#) [FNA41060](#) [MSVB54](#)  
[MSVBTC50E](#) [MSVCPM4-63-12](#) [MSVTA120](#) [FSB50550AB](#) [NCV70501DW002G](#) [LC898301XA-MH](#) [LV8413GP-TE-L-E](#) [MSVGW45-14-3](#)  
[MSVGW45-14-4](#) [MSVGW45-14-5](#) [MSVGW54-14-4](#) [STK984-091A-E](#) [SLA7026M](#) [MP6519GQ-Z](#) [LB11651-E](#) [IRSM515-025DA4](#)  
[LV8127T-TLM-H](#) [NCP81382MNTXG](#) [TDA21801](#) [LB11851FA-BH](#) [NCV70627DQ001R2G](#) [LB1938FAGEVB](#) [IGCM04G60GAXKMA1](#)  
[IKCM15H60HA](#) [TB6569FTG,8,EL](#)