



MxL86110

Ethernet PHY

Single Port Gigabit Ethernet PHY

MxL86110C

MxL86110I

Data Sheet

Revision 1.1, 2023-02-20

Reference ID 620799

Legal Notice

The content of this document is furnished for informational use only, is subject to change without notice, and should not be construed as a commitment by MaxLinear, Inc. MaxLinear, Inc. assumes no responsibility or liability for any errors or inaccuracies that may appear in the informational content contained in this guide. Complying with all applicable copyright laws is the responsibility of the user. Without limiting the rights under copyright, no part of this document may be reproduced into, stored in, or introduced into a retrieval system, or transmitted in any form or by any means (electronic, mechanical, photocopying, recording, or otherwise), or for any purpose, without the express written permission of MaxLinear, Inc.

MaxLinear, Inc. does not recommend the use of any of its products in life support applications where the failure or malfunction of the product can reasonably be expected to cause failure of the life support system or to significantly affect its safety or effectiveness. Products are not authorized for use in such applications unless MaxLinear, Inc. receives, in writing, assurances to its satisfaction that: (a) the risk of injury or damage has been minimized; (b) the user assumes all such risks; (c) potential liability of MaxLinear, Inc. is adequately protected under the circumstances.

MaxLinear, Inc. may have patents, patent applications, trademarks, copyrights, or other intellectual property rights covering subject matter in this document. Except as expressly provided in any written license agreement from MaxLinear, Inc., the furnishing of this document does not give you any license to these patents, trademarks, copyrights, or other intellectual property.

MaxLinear, the MaxLinear logo, any MaxLinear trademarks (MxL, Full-Spectrum Capture, FSC, G.now, AirPHY, Puma, and AnyWAN), and the MaxLinear logo on the products sold are all property of MaxLinear, Inc. or one of MaxLinear's subsidiaries in the U.S.A. and other countries. All rights reserved.

*Other company trademarks and product names appearing herein are the property of their respective owners.

© 2023 MaxLinear, Inc. All rights reserved.

MaxLinear, Inc.
5966 La Place Court, Suite 100
Carlsbad, CA 92008
Tel.: +1 (760) 692-0711
Fax: +1 (760) 444-8598
www.maxlinear.com

Current:	Revision 1.1, 2023-02-20
Previous:	Revision 1.0, 2022-11-30
Page	Major changes since previous revision
All	Removed Preliminary statement from the document.
10	Chapter 1, Product Overview: Updated chapter.
14	Chapter 2, External Signals: Updated chapter.
24	Chapter 3, Functional Description: Updated chapter.
33	Chapter 4, MDIO and MMD Register Interface Description: Updated chapter.
37	Chapter 5.1, Standard Management Registers: Updated chapter.
59	Chapter 5.2, PHY-specific Management Registers: Updated chapter.
72	Chapter 6.1, Standard PCS Registers for MMD=0003_H: Updated chapter.
75	Chapter 6.2, Standard Auto-Negotiation Registers for MMD=0007_H: Updated chapter.
79	Chapter 7.1, Common Extended Register: Updated chapter.
105	Chapter 7.2, UTP Extended Register: Updated chapter.
128	Chapter 8, Electrical Characteristics: Updated chapter.
138	Chapter 9, Package Outline: Updated chapter.
144	Terminology: Updated chapter.

Table of Contents

	Table of Contents	4
	List of Figures	7
	List of Tables	8
	Preface	9
1	Product Overview	10
1.1	Features	11
1.2	Block Diagram	12
1.3	Target Applications	13
2	External Signals	14
2.1	Overview	14
2.2	External Signal Description	15
2.2.1	Pin Diagram	15
2.2.2	Abbreviations	16
2.2.3	Input/Output Signals	17
2.2.3.1	Ethernet Media Interface	17
2.2.3.2	RGMII	17
2.2.3.3	LED Interface	19
2.2.3.4	Management Interfaces	20
2.2.3.5	Miscellaneous Signals	21
2.2.3.6	Power Supply	22
3	Functional Description	24
3.1	Management Interface	24
3.2	Auto-Negotiation (ANEG)	24
3.3	Polarity Detection and Auto Correction	24
3.4	Loopback Mode	25
3.4.1	Near-End Test Loops	25
3.4.2	External Loopback	25
3.4.3	Far-End PHY Loopback	26
3.5	Energy Efficient Ethernet (EEE)	26
3.6	Synchronous Ethernet (SyncE)	26
3.7	Wake-On-LAN (WoL)	27
3.8	Link Down Power Saving (Sleep Mode)	27
3.9	Interrupt	27
3.10	Reset	28
3.11	PHY Address	28
3.12	RGMII Interface	29
3.13	LED Interface	30
3.14	MDINT Pin Usage	30
3.15	Power Supply Rails	31
3.16	Configuration by Pin Strapping	31
4	MDIO and MMD Register Interface Description	33
4.1	Definitions	33
4.2	Register Naming and Numbering	34
4.2.1	Register Numbering	34
4.2.2	Register Naming	34
4.2.3	Examples	34

4.3	MMD Devices Present in MxL86110	35
4.4	Responsibilities of the STA	35
4.5	MDIO Access Protocols to Read / Write Registers	35
5	MDIO Registers Detailed Description	36
5.1	Standard Management Registers	37
5.1.1	Standard Management Registers	38
5.2	PHY-specific Management Registers	59
5.2.1	PHY Specific Function Control Register (Register 16)	60
5.2.2	PHY Specific Status Register (Register 17)	61
5.2.3	Interrupt Mask Register (Register 18)	63
5.2.4	Interrupt Status Register (Register 19)	65
5.2.5	Speed Auto Downgrade Control Register (Register 20)	67
5.2.6	Extended Register's Address Offset Register (Register 30)	69
5.2.7	Extended Register's Data Register (Register 31)	70
6	MMD Registers Detailed Description	71
6.1	Standard PCS Registers for MMD=0003 _H	72
6.1.1	Standard PCS Registers for MMD=0003 _H	73
6.2	Standard Auto-Negotiation Registers for MMD=0007 _H	75
6.2.1	Standard Auto-Negotiation Registers for MMD=0007 _H	76
7	Extended Register Detailed Description	78
7.1	Common Extended Register	79
7.1.1	Chip Configuration Register (Register A001 _H)	80
7.1.2	RGMII Configuration Register 1 (Register A003 _H)	82
7.1.3	RGMII Configuration Register 2 (Register A004 _H)	84
7.1.4	RGMII In-Band Status and MDIO Configuration Register (Register A005 _H)	86
7.1.5	Miscellaneous Control Register (Register A006 _H)	87
7.1.6	Wake on LAN Address Byte 5 and 6 (Register A007 _H)	88
7.1.7	Wake on LAN Address Byte 3 and 2 (Register A008 _H)	89
7.1.8	Wake on LAN Address Byte 1 and 0 (Register A009 _H)	90
7.1.9	Wake on LAN Control Register (Register A00A _H)	91
7.1.10	LED General Configuration Register (Register A00B _H)	92
7.1.11	LED0 Configuration Register (Register A00C _H)	94
7.1.12	LED1 Configuration Register (Register A00D _H)	97
7.1.13	LED2 Configuration Register (Register A00E _H)	99
7.1.14	LED Blinking Configuration Register (Register A00F _H)	101
7.1.15	Pin Driving Strength Configuration Register (Register A010 _H)	102
7.1.16	Pin Driving Strength Configuration Register (Register A012 _H)	104
7.2	UTP Extended Register	105
7.2.1	10 M Base-Te Debug Mode Register (Register 000A _H)	106
7.2.2	Sleep Mode Control Register (Register 0027 _H)	107
7.2.3	Packet Rx Valid High Register (Register 00A3 _H)	108
7.2.4	Packet Rx Valid Low Register (Register 00A4 _H)	109
7.2.5	Packet Rx Oversize High Register (Register 00A5 _H)	110
7.2.6	Packet Rx Oversize Low Register (Register 00A6 _H)	111
7.2.7	Packet Rx Undersize High Register (Register 00A7 _H)	112
7.2.8	Packet Rx Undersize Low Register (Register 00A8 _H)	113
7.2.9	Packet Rx CRC Register (Register 00A9 _H)	114
7.2.10	Packet Rx CRC Oversize Register (Register 00AA _H)	115
7.2.11	Packet Rx Fragment Register (Register 00AB _H)	116
7.2.12	Packet Rx No SFD Register (Register 00AC _H)	117

Table of Contents

7.2.13	Packet Tx High Register (Register 00AD _H)	118
7.2.14	Packet Tx Low Register (Register 00AE _H)	119
7.2.15	Packet Tx Oversize High Register (Register 00AF _H)	120
7.2.16	Packet Tx Oversize Low Register (Register 00B0 _H)	121
7.2.17	Packet Tx Undersize High Register (Register 00B1 _H)	122
7.2.18	Packet Tx Undersize Low Register (Register 00B2 _H)	123
7.2.19	Packet Tx CRC Register (Register 00B3 _H)	124
7.2.20	Packet Tx CRC Oversize Register (Register 00B4 _H)	125
7.2.21	Packet Tx Fragment Register (Register 00B5 _H)	126
7.2.22	Packet Tx No SFD Register (Register 00B6 _H)	127
8	Electrical Characteristics	128
8.1	Absolute Maximum Ratings	128
8.2	Operating Range	129
8.3	AC Characteristics	130
8.3.1	Power Up and Power Down Sequence	130
8.3.2	Power Supply Rail Requirements	130
8.3.3	Device Power Consumption	131
8.3.4	MDIO Interface	131
8.3.5	RGMII Interface	133
8.3.5.1	Transmit Timing Characteristics	133
8.3.5.2	Receive Timing Characteristics	134
8.3.6	Crystal Specification	136
8.3.7	External Clock Requirements	137
9	Package Outline	138
9.1	Thermal Resistance	140
9.2	Chip Identification and Ordering Information	141
	Standards References	143
	Terminology	144

List of Figures

Figure 1	MxL86110 Block Diagram	12
Figure 2	MxL86110 External Signals Overview	14
Figure 3	Pin Diagram for MxL86110	15
Figure 4	Near-End Loopback	25
Figure 5	External Loopback	25
Figure 6	Far-End PHY Loopback	26
Figure 7	EEE Low Power Idle Sequence	26
Figure 8	Block Diagram of WoL Application	27
Figure 9	Reset Timing Diagram	28
Figure 10	Connection Diagram of RGMII	29
Figure 11	LED Circuit Design	30
Figure 12	Power Up and Power Down Sequence	130
Figure 13	Timing Diagram for the MDIO Interface	131
Figure 14	RGMII Transmit Timing Diagram	133
Figure 15	RGMII Receive Timing Diagram	134
Figure 16	PG-QFN-40 Mechanical Drawing	139
Figure 17	Chip Marking	141

List of Tables

Table 1	Abbreviations for Pin Type	16
Table 2	Abbreviations for Buffer Type	16
Table 3	Ethernet Media Interface Signals	17
Table 4	RGMII Interface Signals	17
Table 5	LED Interface Signals	19
Table 6	Management Interface Signals	20
Table 7	Miscellaneous Signals	21
Table 8	Power Supply Pins	22
Table 9	Device Ground	23
Table 10	Reset Timing Characteristics	28
Table 11	Pin Names Used for Pin Strapping	31
Table 12	Pin Strapping Configuration Description	31
Table 13	MMD Devices Present in MxL86110	35
Table 14	MDIO Register Access Type	36
Table 15	Registers Overview - Standard Management	37
Table 16	Registers Overview - PHY-specific Management Registers	59
Table 17	MMD Register Access Type	71
Table 18	Registers Overview - Standard PCS Registers	72
Table 19	Registers Overview - Standard Auto-Negotiation Registers	75
Table 20	Extended Register Access Type	78
Table 21	Registers Overview - Common Extended Register	79
Table 22	Registers Overview - UTP Extended Register	105
Table 23	Absolute Maximum Ratings	128
Table 24	Supply Voltage and Temperature	129
Table 25	Sequence Timing Parameters	130
Table 26	Device Power Consumption	131
Table 27	Maximum Device Power Consumption	131
Table 28	Timing Characteristics of the MDIO Interface	132
Table 29	RGMII Transmit Timing Characteristics	133
Table 30	RGMII Receive Timing Characteristics	134
Table 31	Specification of the Crystal	136
Table 32	Specification of the External Clock	137
Table 33	PG-QFN-40 Mechanical Dimensions	138
Table 34	Thermal Resistance	140
Table 35	Chip Marking Pattern	141
Table 36	Chip Ordering Information	141
Table 37	Chip Specific Information	142

Preface

This Data Sheet describes the features and system architecture of the single port Gigabit Ethernet PHYs MxL86110C and MxL86110I.

Note: The device address map is considered as a flat address map implementation. No Mailbox functionality behind MDIO IF.

This document uses this synonym to simplify matters:

MxL86110

Synonym used for the Ethernet PHYs MxL86110C and MxL86110I

Organization of this Document

- **Chapter 1, Product Overview**
This chapter provides an overview.
- **Chapter 2, External Signals**
This chapter provides the external signals.
- **Chapter 3, Functional Description**
This chapter provides the function description.
- **Chapter 4, MDIO and MMD Register Interface Description**
This chapter describes the MDIO and MMD register format.
- **Chapter 5, MDIO Registers Detailed Description**
This chapter details the MDIO registers.
- **Chapter 6, MMD Registers Detailed Description**
This chapter details the MDD registers.
- **Chapter 7, Extended Register Detailed Description**
This chapter details the extended register.
- **Chapter 8, Electrical Characteristics**
This chapter provides the electrical specifications.
- **Chapter 9, Package Outline**
This chapter provides information about the package.
- **Standards References**
- **Terminology**

Attention: MaxLinear only guarantees the behavior of the device based on documented registers.

The device does not offer any protection against access to other non-documented addresses over the MDIO interface.

1 Product Overview

The MxL86110 is a low power Ethernet PHY transceiver integrated circuit following the IEEE 802.3 [1] standard. It offers a cost-optimized solution that is well-suited for routers, switches, and home gateways. It performs data transmission on an Ethernet twisted pair copper cable of category CAT5e or higher. The MxL86110 supports 1000, 100, and 10 Mbit/s data rates.

On the Ethernet twisted pair interface, the MxL86110 is compliant with the 1000BASE-T (IEEE802.3 Clause 40), 100BASE-TX (IEEE 802.3 Clause 25), and 10BASE-Te (IEEE 802.3 Clause 14) standards defined by the IEEE 802.3 see [1] for more information. This interface supports the Energy-Efficient Ethernet (EEE) feature in accordance with IEEE802.3 [1] to reduce idle mode power consumption. Power saving at the system level is also possible with the Wake-on-LAN feature. A low-EMI line driver with integrated termination facilitates PCB design.

The MxL86110 supports a standard MDIO management interface as defined in IEEE 802.3 Clause 22 and Clause 45 [1]. The MDIO serial interface operates with a clock running up to 12.5 MHz. This allows a management entity (the external chip implementing the MAC) to access standard MDIO / MMD registers to control the MxL86110 behavior, or to read the link status. In addition, vendor specific register banks allow MxL86110-specific configuration of LED, and Wake-on-LAN features. The MDIO and MMD registers are documented in [Chapter 5](#) and [Chapter 6](#), respectively. The MxL86110 is also configurable via pin strapping.

The MxL86110 can drive up to three LEDs. Each LED is independently programmable to indicate the link speed, and traffic activity. Several indication schemes are selectable.

A DC/DC converter is integrated within the MxL86110. A single external power supply of 3.3 V is sufficient to power the chip, with the internal DC/DC converter generating 1.1 V to supply the low voltage domains. External supply of both 3.3 V and 1.1 V is also an option.

The MxL86110 is available in a Quad Flat Non-leaded package (PG-QFN-40). It therefore provides an ideal solution for footprint-sensitive applications such as SFP copper modules or Ethernet Controllers. Furthermore, the MxL86110 design supports a reduced external bill of materials, for example through the integration of termination resistors at both the MDI and MII. The CLKOUT pin can optionally be used to provide a 25 MHz reference clock, allowing for multiple PHY devices to be cascaded while using only one crystal.

The MxL86110 uses a PG-QFN-40 package which is 5 x 5 mm in size.

The MxL86110 has a built-in switching regulator for 1.1 V core power.

The MxL86110 has a built-in LDO providing 2.5/1.8 V power for the RGMII I/O interface.

1.1 Features

This section provides an overview of the features supported by the MxL86110.

Communication Interfaces

- The multiple speed, single-port Ethernet PHY interface to the twisted pair cable supports:
 - Ethernet modes and standards: 1000BASE-T (IEEE 802.3), 100BASE-TX (IEEE 802.3) and 10BASE-T (IEEE 802.3)
 - Ethernet twisted pair copper cable of category CAT5 or higher
 - Low EMI voltage mode line driver with integrated termination resistors
 - Transformerless Ethernet for backplane applications
 - Auto-Negotiation (ANEG) with extended next page support
 - Auto-MDIX and polarity correction
 - Auto-Downspeed (ADS)
 - Energy-Efficient Ethernet (EEE) and power down mode
 - Wake-on-LAN (WoL)
 - 10k byte jumbo frame support.
- RGMII Interface
- The management interface supports the communication between the Station Management Entity (STA) and the MxL86110 using:
 - An MDIO slave interface that provides access to the standard registers in the MMD as described in IEEE 802.3 Clause 22 and Clause 45 [1] and listed in [Chapter 5](#) and [Chapter 6](#)
 - An MDIO interface clock of up to 12.5 MHz
 - Three MDIO message frame types as described in IEEE 802.3: Clause 22, Clause 22 Extended, and Clause 45 [1]

LED Interface, which supports:

- Up to three LEDs
- Single color LEDs
- Connection of LED to ground or 3.3 V
- Several LED indication schemes (link/activity, link speed)
- Configuration of LED indication via Extended Registers

Supports one interrupt output to external controller.

Clocking and Timing Features

- 25 MHz crystal operation

Power Supply

- Single 3.3 V power supply, when using the integrated switching regulator to DC/DC converter to generate the 1.1 V power supply rail
- If the internal integrated DC/DC converter is not used, an additional 1.1 V supply must be provided externally
- Built-in LDO for RGMII IO power 2.5/1.8 V

1.2 Block Diagram

Figure 1 shows the block diagram of the MxL86110. The main interfaces are:

- Data interface to a MAC processor, using RGMII
- Slave control interface driven by a MAC processor, using MDIO slave
- Interrupt signal MDINT allowing the MxL86110 to notify the MAC processor about a change of status
- LED control
- Twisted Pair Interface (TPI)

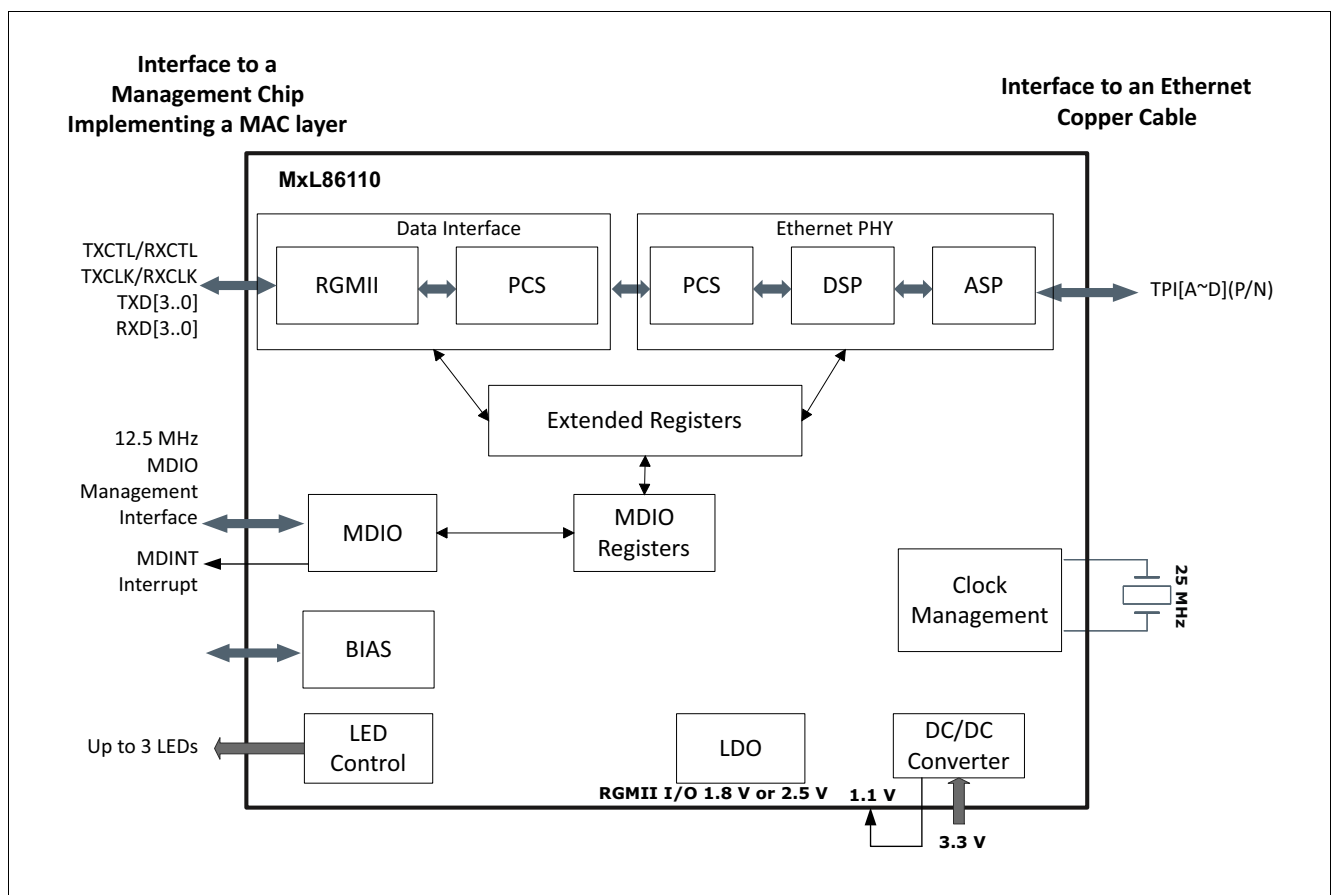

Figure 1 MxL86110 Block Diagram

1.3 Target Applications

- Gateways
- Routers
- Wi-Fi access points
- Set-top-boxes
- IP-phones
- Digital TVs
- Ethernet switches
- NAS
- DVD Players
- Game consoles
- Printers
- Office machines
- Industrial PCs
- IoT devices
- PoE applications

2 External Signals

This chapter describes the signal mapping to the package.

2.1 Overview

Figure 2 provides an overview of the external interfaces of the MxL86110.

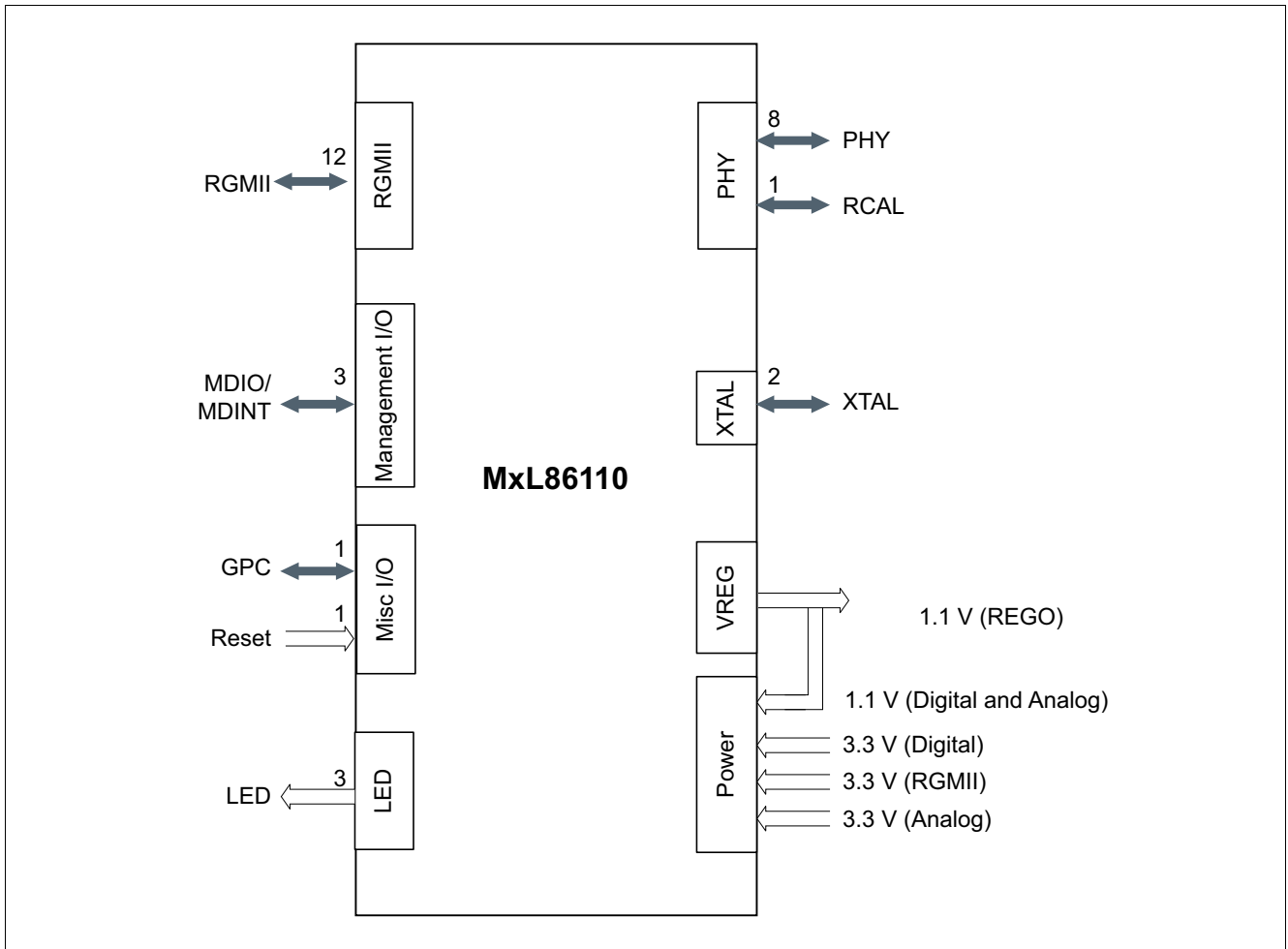

Figure 2 MxL86110 External Signals Overview

2.2 External Signal Description

This section provides the pin diagram, abbreviations for pin types and buffer types, as well as tables describing the input and output signals.

2.2.1 Pin Diagram

Figure 3 shows the pin layout for the MxL86110 package.

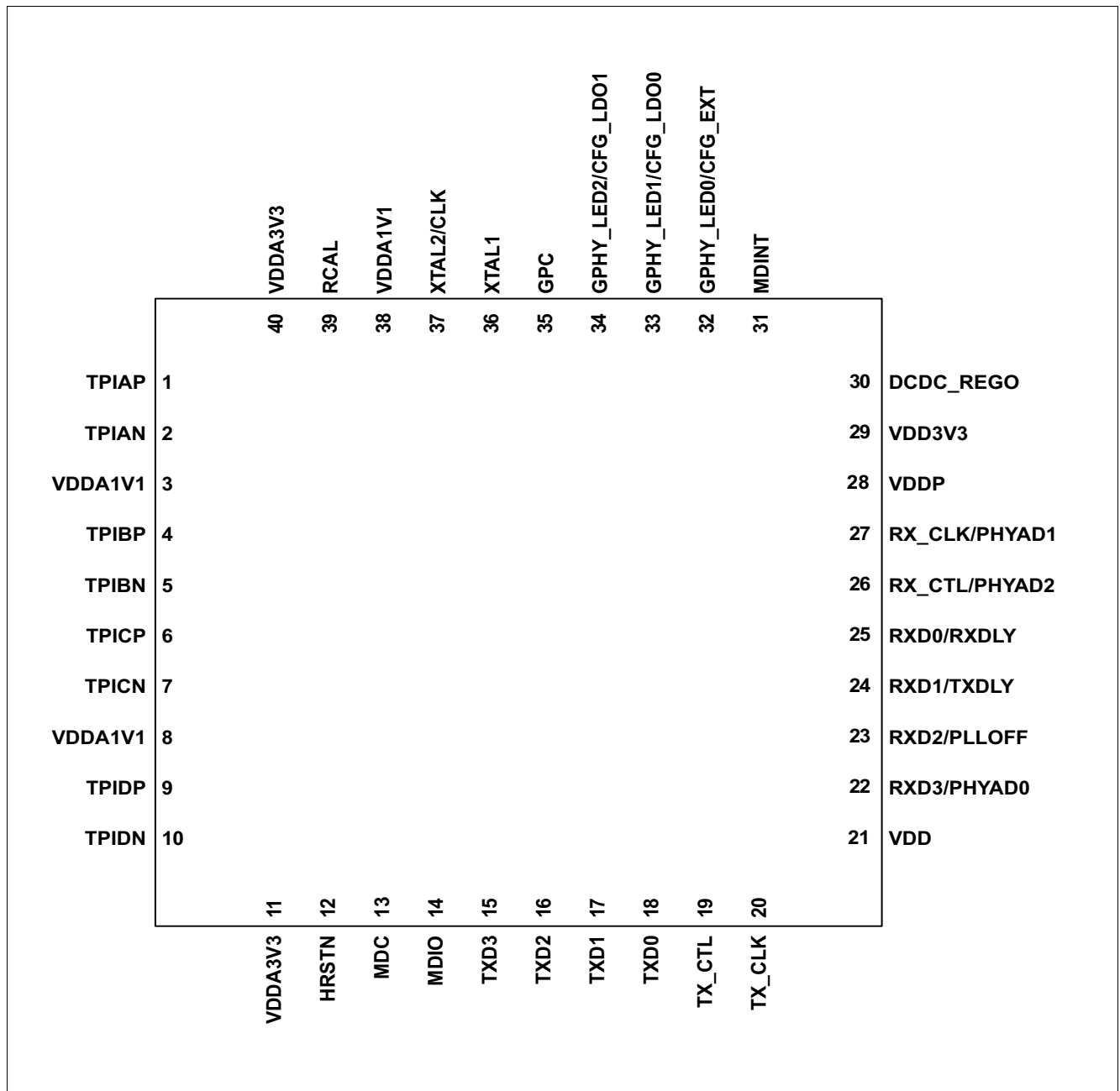

Figure 3 Pin Diagram for MxL86110

2.2.2 Abbreviations

Abbreviations that are used in the signal tables are summarized in [Table 1](#) and [Table 2](#).

Table 1 Abbreviations for Pin Type

Abbreviations	Description
I	Input only, digital levels
O	Output only, digital levels
I/O	Bidirectional input/output signal, digital levels
AI	Input only, analog levels
AO	Output only, analog levels
AI/O	Bidirectional, analog levels
PWR	Power
GND	Ground

Table 2 Abbreviations for Buffer Type

Abbreviations	Description
A	Analog characteristics, see the AC/DC specification for more detail
GND	Ground
OD	Open Drain
PU	Internal pull-up resistor
PD	Internal pull-down resistor

2.2.3 Input/Output Signals

A detailed description of all the pins is given in [Table 3](#) to [Table 7](#).

In [Table 3](#) to [Table 7](#), the signal names highlighted in bold are the same as the pin name. Signal names are provided in bold. The primary function is listed first and then alternate functions.

2.2.3.1 Ethernet Media Interface

[Table 3](#) describes the Ethernet Media Interface's TPI pins which uses pins 1-10.

Table 3 Ethernet Media Interface Signals

Pin No.	Name	Pin Type	Buffer Type	Function
Ethernet Port Ethernet Media Interface				
1	TPIAP	AI/AO	A	Twisted Pair Transmit/Receive Positive/Negative
2	TPIAN	AI/AO	A	
4	TPIBP	AI/AO	A	
5	TPIBN	AI/AO	A	
6	TPICP	AI/AO	A	
7	TPICN	AI/AO	A	
9	TPIDP	AI/AO	A	
10	TPIDN	AI/AO	A	

2.2.3.2 RGMII

[Table 4](#) describes the RGMII interface-related pins which uses pins 15-20 and 22-27.

Table 4 RGMII Interface Signals

Pin No.	Name	Pin Type	Buffer Type	Function
RGMII Interface Signals				
15	TXD3	I	PD	RGMII: Transmit Data Bit 3 This pin carries bit 3 of the TXD[3:0] RGMII transmit data vector. It is synchronous with TXC.
16	TXD2	I	PD	RGMII: Transmit Data Bit 2 This pin carries bit 2 of the TXD[3:0] RGMII transmit data vector. It is synchronous with TXC.
17	TXD1	I	PD	RGMII: Transmit Data Bit 1 This pin carries bit 1 of the TXD[3:0] RGMII transmit data vector. It is synchronous with TXC.
18	TXD0	I	PD	RGMII: Transmit Data Bit 0 This pin carries bit 0 of the TXD[3:0] RGMII transmit data vector. It is synchronous with TXC.
19	TX_CTL	I	PD	RGMII: Transmit Control This pin is the transmit control signal for the TXD[3:0] RGMII transmit data vector. It is synchronous with TXC.

Table 4 RGMII Interface Signals (cont'd)

Pin No.	Name	Pin Type	Buffer Type	Function
20	TX_CLK	I	PD	RGMII: Transmit Clock The TXC signal is a continuous clock signal and provides the timing reference for the transfer of TX_EN_CTL and TXD[3:0]. The nominal frequency of this clock is 125 MHz for 1000 Mbit/s, 25 MHz for 100 Mbit/s, and 2.5 MHz for 10 Mbit/s. Depending on the speed selection, this clock is assumed to be properly adjusted by the MAC. The frequency deviation is assumed to be smaller than +/- 50 ppm.
22	RXD3 /PHYAD0	I/O	PD	RGMII: Receive Data Bit 3 This pin carries bit 3 of the RXD[3:0] RGMII receive data vector. It is synchronous with RXC. PHYAD0: This pin reads in soft pin-strapping information during reset.
23	RXD2 /PLLOFF	I/O	PD	RGMII: Receive Data Bit 2 This pin carries bit 2 of the RXD[3:0] RGMII receive data vector. It is synchronous with RXC. PLLOFF: This pin reads in soft pin-strapping information during reset.
24	RXD1 /TXDLY	I/O	PD	RGMII: Receive Data Bit 1 This pin carries bit 1 of the RXD[3:0] RGMII receive data vector. It is synchronous with RXC. TXDLY: This pin reads in soft pin-strapping information during reset.
25	RXD0 /RXDLY	I/O	PD	RGMII: Receive Data Bit 0 This pin carries bit 0 of the RXD[3:0] RGMII receive data vector. It is synchronous with RXC. RXDLY: This pin reads in soft pin-strapping information during reset.
26	RX_CTL /PHYAD2	I/O	PD	RGMII: Receive Control This is the receive control signal driven by the PHY, and which is synchronous with RXC. The signal encodes the RX_DV and RX_ER signals of the GMII. PHYAD2: This pin reads in soft pin-strapping information during reset.
27	RX_CLK /PHYAD1	I/O	PD	RGMII: Receive Clock The RXC signal is a continuous clock signal and provides the timing reference for the transfer of RX_EN_CTL and RXD[3:0]. The nominal frequency of this clock is 125 MHz for 1000 Mbit/s, 25 MHz for 100 Mbit/s and 2.5 MHz for 10 Mbit/s. The frequency deviation is smaller than +/-50 ppm. PHYAD1: This pin reads in soft pin-strapping information during reset.

2.2.3.3 LED Interface

Table 5 describes the LED interface-related pins which allow external LEDs to be connected to the MxL86110C/MxL86110I to indicate the status of the Ethernet PHY interfaces. The LED interface uses pins 32-34.

Table 5 LED Interface Signals

Pin No.	Name	Pin Type	Buffer Type	Function
LED Signals				
32	GPHY_LED0 /CFG_EXT	I/O	PU	GPHY LED0 The LED control output drives single color LEDs. CFG_EXT : This pin reads in soft pin-strapping information during reset.
33	GPHY_LED1 /CFG_LDO0	I/O	PU	GPHY LED1 The LED control output drives single color LEDs. CFG_LDO0 : This pin reads in soft pin-strapping information during reset.
34	GPHY_LED2 /CFG_LDO1	O	PD	GPHY LED2 The LED control output drives single color LEDs. CFG_LDO1 : This pin reads in soft pin-strapping information during reset.

2.2.3.4 Management Interfaces

Table 6 describes the MIDO slave interface pins which uses pins 13, 14, and 31

Table 6 Management Interface Signals

Pin No.	Name	Pin Type	Buffer Type	Function
MDIO Slave Interface				
13	MDC	I	PD	MDIO Slave Clock The external controller host, also called STA by the IEEE, acts as clock master and provides the serial clock of up to 12.5 MHz on this input.
14	MDIO	I/O	PU	MDIO Slave Data Input/Output The external controller host uses this signal to address internal registers and to transfer data to and from the internal registers.
31	MDINT	O	OD	MDIO Interrupt The MDINT signal is used to send an interrupt to an external MAC SoC acting as station manager (STA).

2.2.3.5 Miscellaneous Signals

Table 7 lists miscellaneous signals required by the device.

Table 7 Miscellaneous Signals

Pin No.	Name	Pin Type	Buffer Type	Function
Reset and Clocking				
37	XTAL2	AO	A	Crystal: Oscillator Output A crystal must be connected between XTAL1 and XTAL2. Additional load capacitances must also tie both pins to GND.
	CLK	I		Clock: Clock Input The clock must have a frequency accuracy of ± 50 ppm. When connecting an external 25 MHz oscillator or clock from another device to XTAL2 pin, XTAL1 must be tied to GND.
36	XTAL1	AI	A	Crystal: Oscillator Input A crystal must be connected between XTAL1 and XTAL2. Additional load capacitances must also tie both pins to GND.
35	GPC	O		General Purpose Clock 1. This is the reference clock generated from the internal PLL. This pin should be kept floating if the clock is not used by the MAC. 2. UTP recovery receive clock for Sync Ethernet. 3. 25 MHz reference clock.
12	HRSTN	I	PU	Hardware Reset Asynchronous active low device reset.

2.2.3.6 Power Supply

This section specifies the power supply pins. The device is supplied by two supply rails, V_{HIGH} (3.3 V) and V_{LOW} (1.1 V). The V_{LOW} domain can either be supplied externally, or self-generated by the internal DC/DC Selecting Voltage Regulator (SVR) converter, which converts the VDD3V3 supply into DCDC_REGO output. In the external supply configuration, the DCDC_REGO output pins are not connected (NC). In the internal DC/DC SVR converter configuration, the DCDC_REGO output pins are connected back to the V_{LOW} supply inputs.

Table 8 Power Supply Pins

Pin No.	Name	Pin Type	Buffer Type	Function
Power Supply Pins				
11, 40	VDDA3V3	PWR		High Voltage Domain Supply V_{HIGH} These are the input power pins for the analog front end in the high voltage domain. They must be supplied with a nominal voltage of $V_{DDA3V3} = 3.3$ V.
3, 8, 38	VDDA1V1	PWR		Low Voltage Domain Supply V_{LOW} These are the input power supply pins for the low voltage domain. These pins must be supplied with a nominal voltage of 1.1 V. When the internal DC/DC SVR converter is used, they must be connected to the output of the converter DCDC_REGO.
28	VDDP	PWR		Configurable MDIO Pin Voltage Domain Supply The voltage domains for the digital RGMII I/O and MDC/MDIO are controlled by the pins CFG_EXT, CFG_LDO0, and CFG_LDO1. Refer to Section 3.16 for the settings. No matter whether the I/O pin power form external or internal, a bulk capacitor and a decoupling capacitor should be connected to this pin.
21	VDD	PWR		Core Voltage Domain Supply V_{LOW} This is the group of supply pins for the core digital voltage domain. This pin must be supplied with a nominal voltage of $V_{DD} = 1.1$ V. When the internal DC/DC SVR converter is used, these pins must be connected to the output of the converter DCDC_REGO.
29	VDD3V3	PWR		Power Supply V_{HIGH} This pin must be supplied with a nominal voltage of $V_{DD3V3} = 3.3$ V.
30	DCDC_REGO	PWR		Internal DC/DC SVR Converter Output The connection circuitry for the internal DCDC SVR V_{LOW} supply option and the external V_{LOW} supply option are described in Figure 16 .
Ethernet Port Calibration				
39	RCAL	AI/AO	A	Calibration of GPHY Ethernet Port Connect a high precision resistor of 2.49 k Ω \pm 1% to GND

Table 9 **Device Ground**

Pin No.	Name	Pin Type	Buffer Type	Function
EPAD ¹⁾	VSS	GND		General device ground

1) The EPAD is the exposed pin on the bottom of the package. This pin must be properly connected to the ground plane of the PCB.

3 Functional Description

This chapter describes the functions available to the MxL86110.

3.1 Management Interface

The status and control registers of the device are accessible through the MDIO and MDC serial interface. The functional and electrical properties of this management interface comply with IEEE 802.3, Section 22 and also support MDC clock rates up to 12.5 MHz.

3.2 Auto-Negotiation (ANEG)

The MxL86110 negotiates its operation mode using the ANEG mechanism according to IEEE 802.3 Clause 28 over the copper media. ANEG supports choosing the mode of operation automatically by comparing its own abilities and received abilities from link partner. The advertised abilities include:

- Speed: 10/100/1000Mbps
- Duplex mode: full-duplex and/or half-duplex

ANEG is initialized when these scenarios occur:

- Power-up/Hardware/Software reset
- ANEG restart
- Transition from power down to normal operation of the port
- Link down

ANEG is enabled for MxL86110 by default, and can be disabled by software control.

3.3 Polarity Detection and Auto Correction

The MxL86110 can detect and correct two types of cable errors.

- Swapped pairs within the UTP cable:
 - Pair 0 and 1, and/or pair 2 and 3.
- Swapped wires within a pair.

3.4 Loopback Mode

The MxL86110 supports several test loops to support system integration.

3.4.1 Near-End Test Loops

Digital loopback provides the ability to loop transmitted data back to the receiver using digital circuitry in the MxL86110.

The near-end test loops are used to verify system integration of an MxL86110 device. They allow for closed loopback of data and signals at different Open Systems Interconnection (OSI) reference layers. [Section 3.4.2](#) and [Section 3.4.3](#) describe these loopback functions in descending order of OSI abstraction layer. Digital loopback is set via `STD_CTRL.LB = 1b`. See [Section 5.1.1](#).

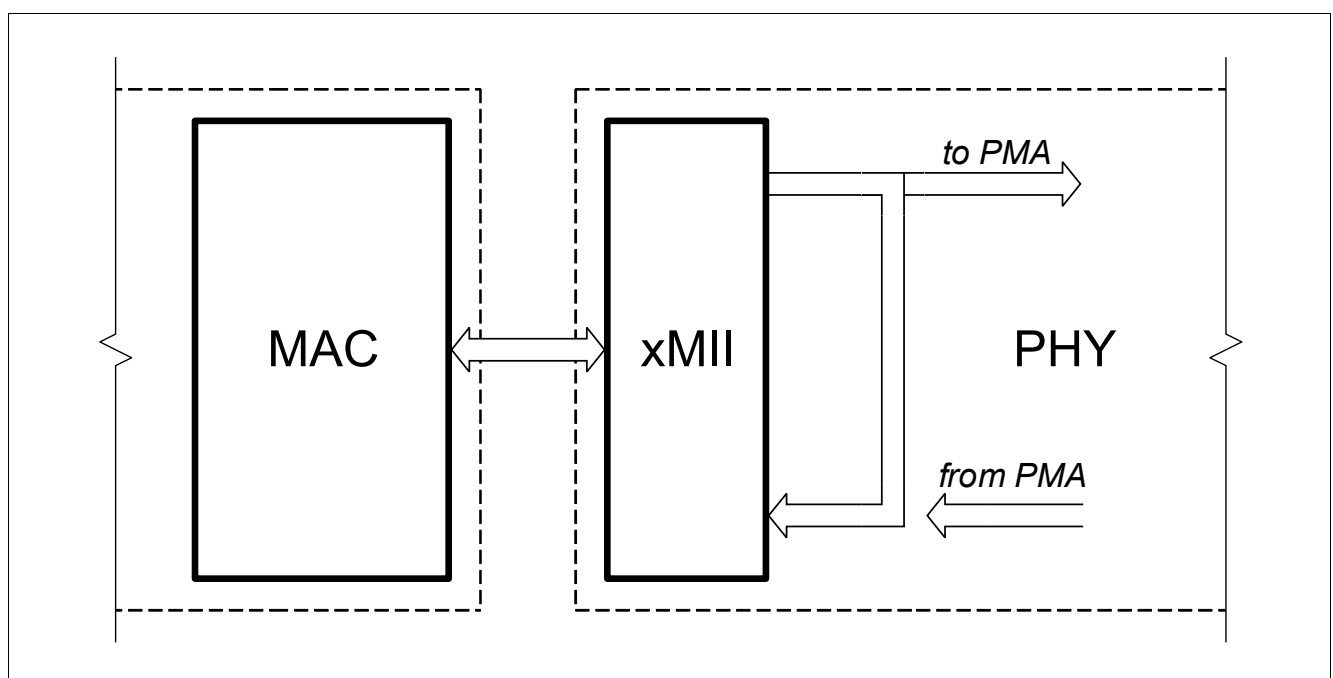

Figure 4 Near-End Loopback

3.4.2 External Loopback

The MxL86110 supports an external loopback with help of a physical connection at the RJ45 connector as shown in [Figure 5](#). This allows a complete Tx -> Rx cable loopback.

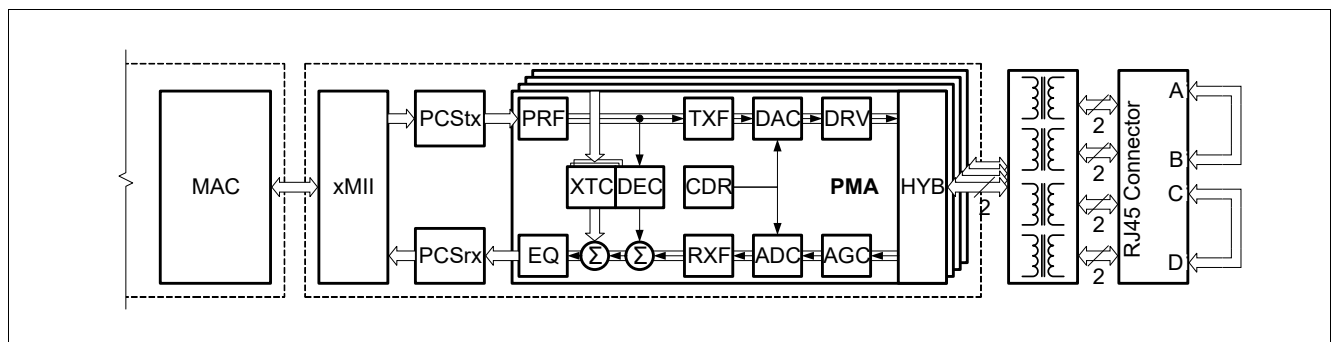

Figure 5 External Loopback

Note: External loopback is set via `UTP_EXT_10BT_DBG.ELB`. See [Section 7.2](#).

3.4.3 Far-End PHY Loopback

The Far-End loopback mode connects the MDI Rx path to the MDI Tx path close to RGMII interface as shown in [Figure 6](#). With this function the Far-End PHY can detect the proper connectivity.

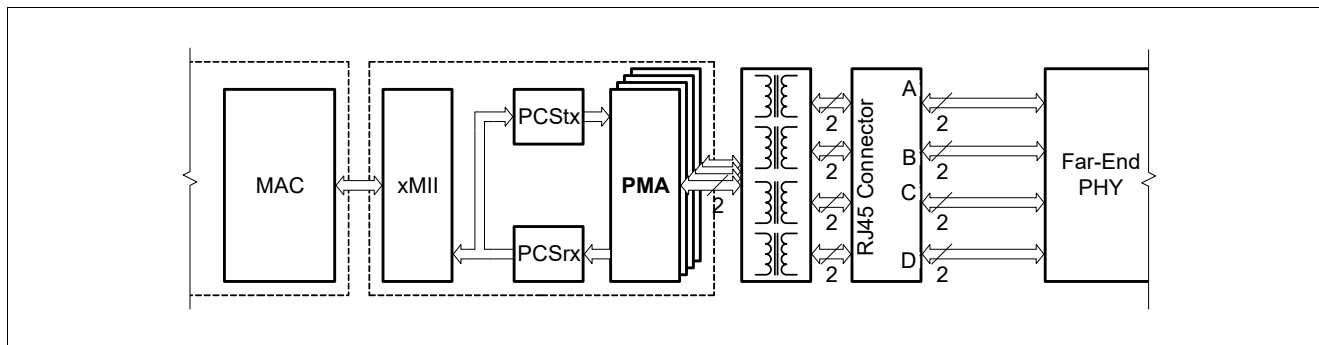

Figure 6 Far-End PHY Loopback

Note: Remote PHY loopback is set via `COM_EXT_MISC_CFG.RLBP`. See [Section 7.2](#).

3.5 Energy Efficient Ethernet (EEE)

The IEEE 802.3 standard [1] describes the EEE operation that is supported by the MxL86110. EEE is supported in the various speeds of 100BASE-TX and 1000BASE-T. The general idea of EEE is to save power during periods of low link utilization. Instead of sending active idle data, the transmitters are switched off for a short period of time. This is called the quiet period in the standard. The link is kept active by means of a frequent refresh cycle initiated by the PHY itself while in the low power state. This sequence is repeated until a wake request is generated by one of the link partner MACs.

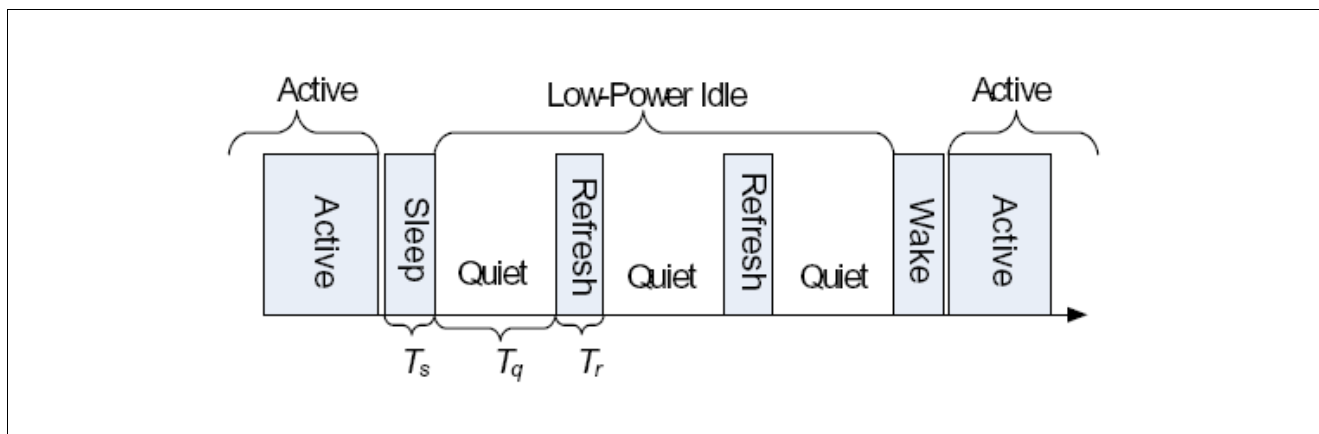

Figure 7 EEE Low Power Idle Sequence

3.6 Synchronous Ethernet (SyncE)

The MxL86110 provides Synchronous Ethernet (SyncE) support when the device is operating in 1000BASE-T and 100BASE-TX on the transmission media. The GPC pin can be assigned to output the recovered clock.

The MxL86110 allows a SyncE interface to support transportation of a source-referable clock from a clock master to clock clients. This is supported in 1000BASE-T and 100BASE-T mode on the TPI.

- In 1000BASE-T, the GPC outputs the recovered clock from PHY<->PHY.
- In slave mode, the GPC outputs the recovered clock from MDI.
- In master mode, the GPC outputs the clock from local free running PLL.

When the GPC pin is assigned to output the recovered clock from the PHY and the PHY is configured for 1000BASE-T mode, the function of the GPC varies depending upon the current PHY mode.

- When the PHY is in slave mode, the GPC outputs the recovered clock from the MDI.
- When the device is in master mode, the GPC outputs the clock based on the local free run PLL.

3.7 Wake-On-LAN (WoL)

The MxL86110 supports WoL. The MxL86110 generates an interrupt to an external controller when it detects special WoL Ethernet packets. This allows the controller to enter into sleep mode when there is no Ethernet traffic to process, and be woken up when traffic starts. WoL packets are detected at all link speeds. [Figure 8](#) shows this scenario. The specific frame contains a specific data sequence located anywhere inside the packet. The 48-bit address is set using the COM_EXT_MAC_ADDR_CFG1, COM_EXT_MAC_ADDR_CFG2, and COM_EXT_MAC_ADDR_CFG3 registers. See [Section 7.1](#).

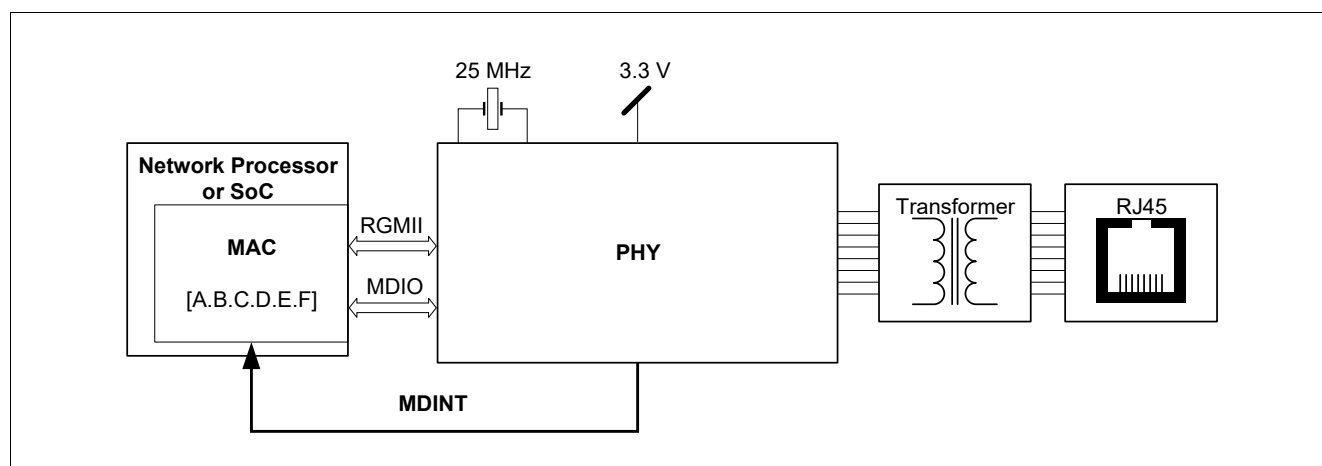

Figure 8 Block Diagram of WoL Application

The most commonly used WoL packet is called a magic packet. A magic packet contains the MAC address of the device to be woken up.

3.8 Link Down Power Saving (Sleep Mode)

The MxL86110 supports link down power saving, also called sleep mode. The MxL86110 enters sleep mode after around 40 seconds if no signals are received over the Ethernet cable.

In sleep mode, the MxL86110 disables almost all circuits, nevertheless access by MDC/MDIO interface remains available.

Once signals are detected on an Ethernet cable, the MxL86110 exits sleep mode automatically.

3.9 Interrupt

The MxL86110 provides an active low interrupt output signal (MDINT) based on change of the PHY status. Every interrupt condition is mapped to the read-only general interrupt status register by the read-only general interrupt status register. See [Section 5.2](#) for more information.

The interrupts can be individually enabled or disabled by setting or clearing bits in the interrupt enable register [Section 5.2](#). See PHY_IMASK [Section 5.2.3](#).

The MDINT signal is used to send an interrupt to an external MAC SoC acting as station manager (STA). The STA can program its sensitivity to specific events using the PHY_IMASK register. The MDINT event is then raised when the event occurs. The STA can read which type of event occurred in the PHY_ISTAT register. Upon reading of PHY_ISTAT by the STA, the MDINT is deasserted by the MxL86110.

Note: The interrupt of the MxL86110 is a level-triggered mechanism.

3.10 Reset

The MxL86110 has a hardware reset (HRSTN) pin. The HRSTN signal must be active for at least 10 ms after power-up. After the HRSTN is released, the MxL86110 latches the input values on the strapping pins to configure the device settings. This is useful for configuring the device in applications where MDIO access is unavailable. After a hardware reset, there is a 100 ms MDIO access delay to complete MxL86110 internal initialization.

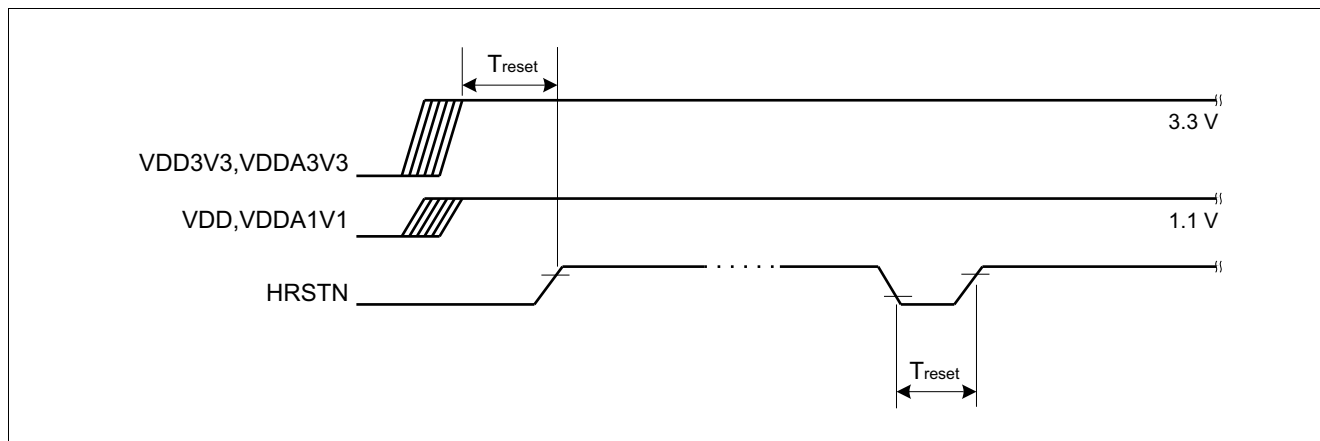

Figure 9 Reset Timing Diagram

Table 10 Reset Timing Characteristics

Symbol	Description	Min.	Typ.	Max.	Units
T_{reset}	The amount of time to allow all power rails to stabilize before releasing HRSTN to high.	10	-	-	ms
T_{reset}	The minimum amount of time for a reset signal to be recognized.	10	-	-	ms

3.11 PHY Address

The MxL86110 offers the ability to configure the PHY address from the pins PHYAD1/PHYAD2. In addition, MxL86110 supports broadcast address 0 on the MDIO bus. This feature enables PHY to always respond to MDIO access. It is controlled via the COM_EXT_RGMII_MDIO_CFG register. See [Section 7.1](#) for more information.

The MxL86110 supports the option to configure a dedicated broadcast PHY address.

3.12 RGMII Interface

The RGMII interface implements a MAC interface which is usable for all supported speeds (10/100/1000 Mbit/s). The transfer of data between the MAC and PHY devices is handled via a clock signal, a control signal, and a four bit data vector in both the transmit and receive directions. The clock signal is always driven by the signal source, which is the MAC in the transmit direction and PHY in the receive direction. The control and data signals change with both the rising and falling edges of the driving clock.

The nominal driving clock frequency at 1000 Mbit/s data speeds is 125 MHz. Lower speeds of 100 Mbit/s and 10 Mbit/s use a clock frequency of 25 MHz and 2.5 MHz respectively. At these lower speeds, the higher half of the data octet is empty and the signals on TXD[3:0] and RXD[3:0] are duplicated.

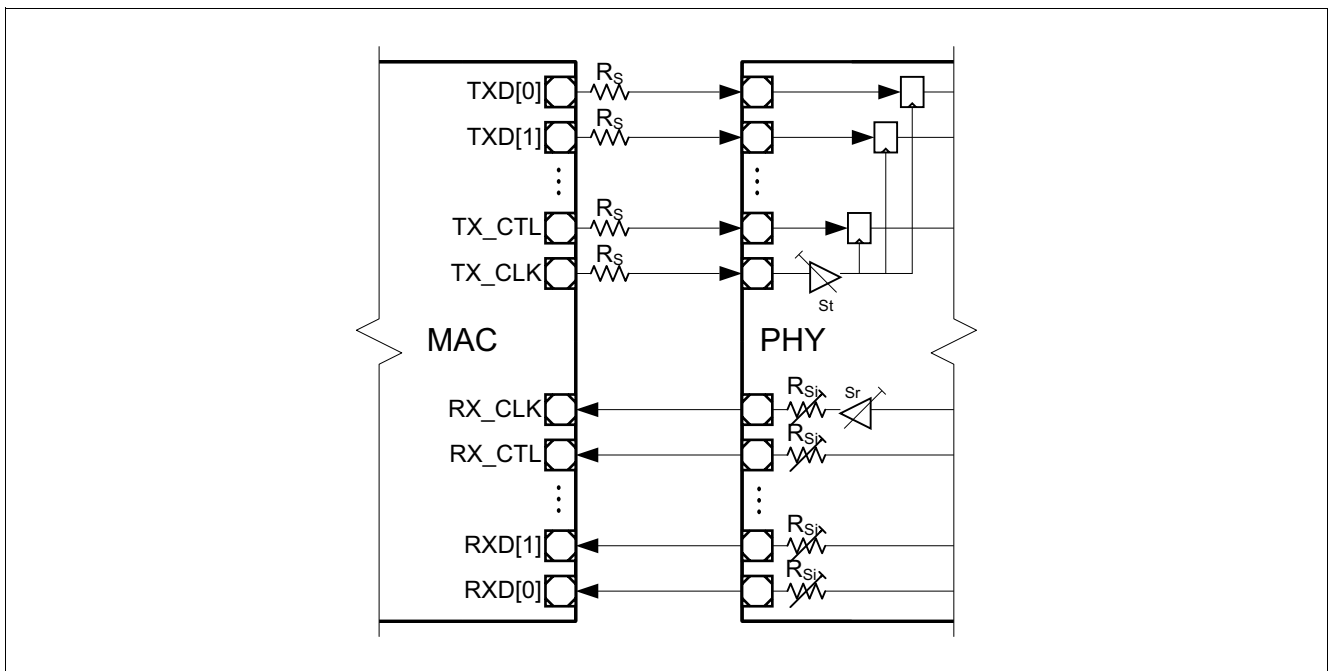

Figure 10 Connection Diagram of RGMII

3.13 LED Interface

The LED interface is controllable by two methods: by the PHY or manually controlled. The LED interface provides up to three LEDs to provide visual indication of the link speed, duplex, and link status. The LEDs are programmable by the MDIO interface via direct register access. **Figure 11** shows the LED circuit design.

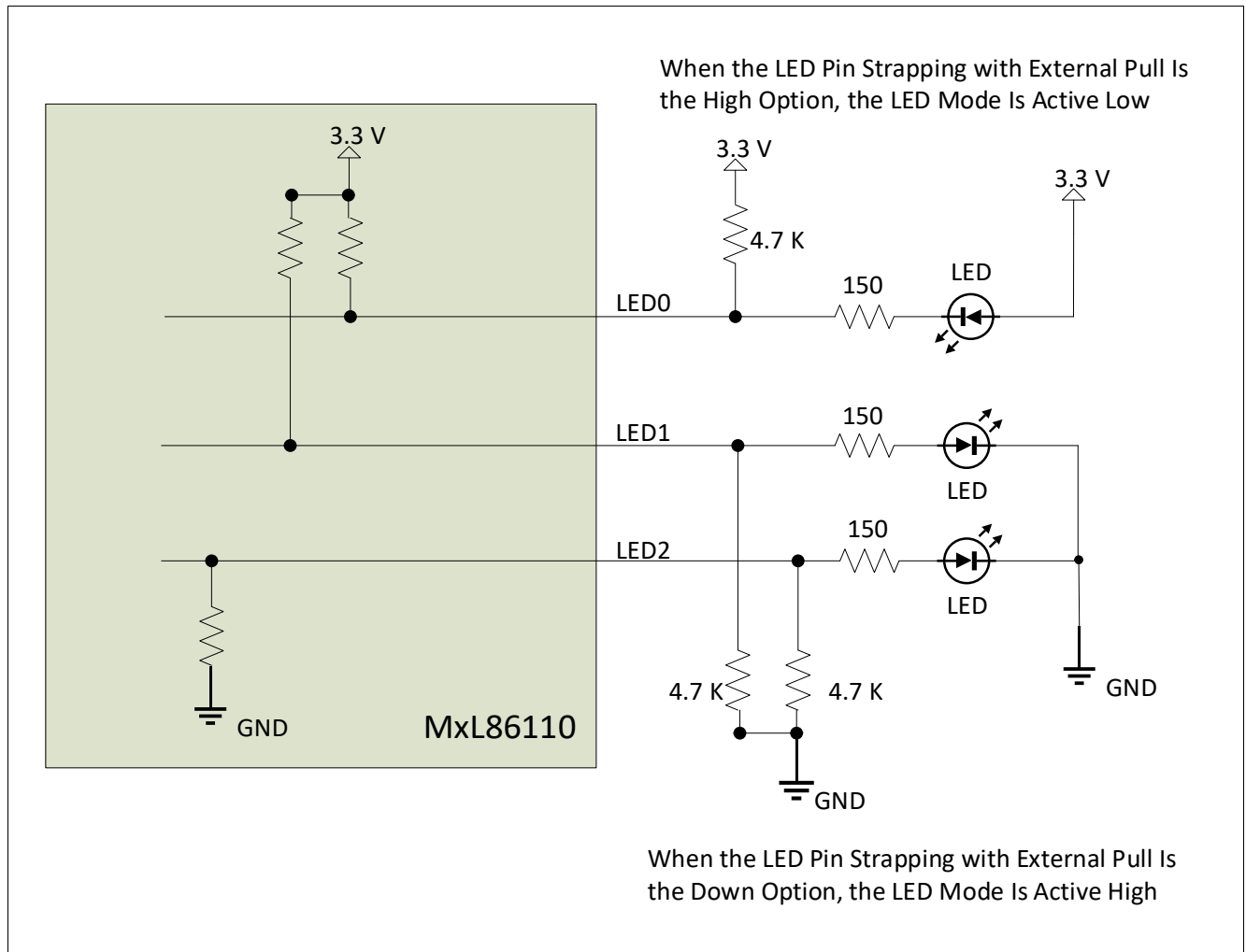

Figure 11 LED Circuit Design

3.14 MDINT Pin Usage

The MDINT pin is used to notify the network processor, or SoC, of both interrupt and WoL events. For general use, indication of a WoL event is also integrated into one of the interrupt events which is triggered when any specified WoL event occurs.

3.15 Power Supply Rails

The MxL86110 requires only one external supply rail of 3.3 V. The device has an integrated SVR which generates the 1.1 V rail, as well as an LDO to adapt to different RGMII levels (either 2.5 / 1.8 V).

The RGMII I/O voltage level is set via external strapping.

When the integrated SVR is not used, the MxL86110 can be powered by a 3.3 V and 1.1 V dual power supply. See [Section 8.2](#) for more information on the electrical characteristics of the power supply. In external supply mode, the DCDC_REGO output pins are left unconnected. The integrated SVR converter is able to be switched off after power up.

3.16 Configuration by Pin Strapping

The MxL86110 device can be configured by means of pin strapping several pins. The pin strapping configurations are captured during the chip power-on sequence, until the reset initialization is complete. The pin strap values can be set to logical high or low by connecting the corresponding pin via an external 1 kΩ resistor to either ground or the VDD domain supply for the pin strapping pins. For example, GPHY_LED0/1/2 connects to either ground or 3.3 V and RXD3/2/1/0/RX_CLK/RXCTL connects to either ground or the VDDP domain.

The pin strap mapping is described in [Table 11](#) and [Table 12](#).

Table 11 Pin Names Used for Pin Strapping

Pin Name	Pin Number	Configuration Item Description
RXD3	22	PS_PHY_MADDR(0)
RXD2	23	PLLOFF
RXD1	24	TXDLY
RXD0	25	RXDLY
RX_CTL	26	PS_PHY_MADDR(2)
RX_CLK	27	PS_PHY_MADDR(1)
GPHY_LED0	32	CFG_EXT
GPHY_LED1	33	CFG_LDO0
GPHY_LED2	34	CFG_LDO1

Table 12 Pin Strapping Configuration Description

Pin Strapping Signals	Description
PS_PHY_MADDR(2:0)	MDIO PHY Address A high level means a logical 1 and low level means a logical 0.
PLLOFF	PLL off Configuration During Sleep Mode 0 _B PLL is on during sleep mode. 1 _B PLL is off during sleep mode.
TXDLY	RGMII Transmit Clock Timing Control 0 _B No additional delay on TX_CLK. 1 _B Enable 2 ns delay on TX_CLK when TX_CLK is 125 MHz or 8 ns delay on TX_CLK when TX_CLK is 25 MHz/2.5 MHz.
RXDLY	RGMII Receiver Clock Timing Control 0 _B No additional delay on RX_CLK. 1 _B Enable 2 ns delay on RX_CLK when RX_CLK is 125 MHz or 8 ns delay on RX_CLK when RX_CLK is 25 MHz/2.5 MHz.

Table 12 Pin Strapping Configuration Description

Pin Strapping Signals	Description
CFG_EXT	<p>External Power Source Mode Configuration</p> <p>0_B Use the integrated LDO to supply the RGMII/MDIO I/O pin.</p> <p>1_B Use an external power source on VDDP for the RGMII/MDIO I/O pin.</p>
CFG_LDO(1:0)	<p>Configuration of Integrated LDO voltage</p> <p>This is the voltage level configuration for supplying the RGMII/MDIO I/O pin.</p> <p>00_B Reserved</p> <p>01_B 2.5 V</p> <p>10_B 1.8 V</p> <p>1x_B 1.8 V</p>

4 MDIO and MMD Register Interface Description

This chapter describes the MDIO and MMD registers, which are standardized by IEEE 802.3 [1], and available to support the MxL86110 feature set. After power-on, the MxL86110 resets the MDIO and MMD registers to default values that are sufficient to operate without specific programming.

All the register definitions, behaviors, and fields are strictly compliant with the IEEE 802.3 [1]. There are PHY specific registers which are not referenced in IEEE 802.3, which can be found in [Section 5.2](#). These allow custom functions related to the MxL86110.

4.1 Definitions

These acronyms are used in the IEEE 802.3 standard and commonly used in the Ethernet technical domain:

- **STA:** Station Management. A host connected to the MDIO interface. STAs are generally Media Access Controllers (MACs). The STA drives the MDIO bus as a clock master and the MxL86110 is MDIO slave.
- **Host:** Used as a synonym of STA in this document.
- **PHY:** Physical Layer. In the MxL86110 this encompasses Analog Signal Processing, Digital Signal Processing, and Physical Coding Sublayer (PCS). The PHY contains several sub-layers that are individually manageable entities known as MDIO manageable devices (MMDs).
- **MMD:** MDIO Manageable Device. The list of MMDs available in the MxL86110 is in [Section 4.3](#).
- **Device:** In the context of MDIO/MMD registers, a device is a register bank grouped by logical sub-layers of the PHY layer.
- **Clause:** Refers to a particular section of the IEEE 802.3 standard [1]. In particular Clause 22 describes MDIO device 0, and Clause 45 describes the other MMDs.
- **MII:** Media Independent Interface. This encompasses the MDIO as well as the (G)MII as described in Clause 22. STD registers in device 0 are also called MII registers.

4.2 Register Naming and Numbering

The register numbering convention in this document is similar to that of IEEE 802.3:

The numbering syntax uses 3 numbers “a.b.c” as specified in IEEE 802.3 paragraph 45.1, and the notation is generalized to Clause 22 registers in device 0 “STD”. The alphanumeric syntax also uses the same structure and uses the names of the MMD devices, registers and register fields separated by underscore and dot as described below.

4.2.1 Register Numbering

The syntax is as follows, with a, b, c written as decimal numbers:

a.b.c = <DEVICE_NUMBER>.<REGISTER_NUMBER>.<FIELD_NUMBER>

When the last indicator (c) is omitted, the register numbering refers to the full register.

When a field is more than a single bit, the bit range is indicated using a semicolon (e.g. 1:3 is the field of bits 1 to 3). In an MDIO register, the least significant bit is bit 0 and most significant bit is bit 15. All MDIO registers are 16 bit wide.

4.2.2 Register Naming

The syntax is as follows, with AA, BB, CC written as alphanumeric strings:

AA.BB.CC = <DEVICE_NAME>_<REGISTER_NAME>.<FIELD_NAME>

When the last indicator (CC) is omitted, the register naming refers to the full register.

The fields named RES, refer to reserved fields as per IEEE 802.3 documents.

4.2.3 Examples

STD_STAT.ANOK is the name of the field 0.1.5, which indicates auto-negotiation complete.

ANEG_CTRL.ANEG_RESTART is the name of the field 7.0.9, which allows the STA to restart the Ethernet ANEG procedure.

ANEG_PHYID1 is the complete 16-bit register number 7.2, for the PHY identifier 1 number.

4.3 MMD Devices Present in MxL86110

Table 13 lists the devices present in the MxL86110.

Table 13 MMD Devices Present in MxL86110

MDIO / MMD Name	Device Number (decimal)	Description
PCS	3	Control and status registers related to PCS encoding/decoding device.
ANEG	7	Control and status registers related to auto-negotiation device.

4.4 Responsibilities of the STA

The MMD devices implement groups of standardized registers under the management of the STA. They are defined in IEEE 802.3.

As per IEEE 802.3 guidelines, it is the responsibility of the STA entity to ensure that mutually acceptable speeds are applied consistently across all the MMDs of the MxL86110.

4.5 MDIO Access Protocols to Read / Write Registers

All the MDIO/MMD registers can be accessed from an external chip connected to the MDIO bus on the MDIO and MDC pins. The MxL86110 supports several MDIO frame protocols:

- Clause 22: To access Device 0
- Clause 22 Extended: To access other devices (Dev 3: PCS, Dev 7: ANEG,) using the indirection scheme specified by IEEE 802.3.
- Clause 45: to access device as **Table 13**.

Both Clause 22 Extended and Clause 45 can be used to access MMD devices. However, the mechanism implemented in the MxL86110 provides faster speeds using Clause 45, so there are some differences in latencies in the MDIO reply:

- Protocol "Clause 22 Extended" involves the MxL86110 an indirection mechanism.
- Protocol "Clause 45" provides faster replies.

The Clause 22 registers can be accessed using the Clause 45 electrical interface and the Clause 22 management frame structure (IEEE 802.3 section 45.2).

5 MDIO Registers Detailed Description

Table 14 MDIO Register Access Type

Mode	Symbol
Status Register (Status, or Ability Register)	RO
Read-Write Register (e.g. MDIO Register)	RW
Read-Write, Self-Clearing Register. The bit is cleared after being read from the MDIO interface.	RWSC

Attention: *Since the MxL86110 is a 1000 Mbit/s product, the maximum speed capability available in the registers is 1000 Mbit/s. Any speed higher than 1000 Mbit/s, such as 2.5 Gbit/s, 5 Gbit/s, or 10 Gbit/s, defaults to 1000 Mbit/s.*

5.1 Standard Management Registers

This section describes the IEEE 802.3 standard management registers corresponding to Clause 22.

Table 15 Registers Overview - Standard Management

Register Short Name	Register Long Name	Reset Value
STD_CTRL	STD Control (Register 0)	1140 _H
STD_STAT	Status Register (Register 1)	7949 _H
STD_PHYID1	PHY Identifier 1 (Register 2)	C133 _H
STD_PHYID2	PHY Identifier 2 (Register 3)	5580 _H ¹⁾
STD_AN_ADV	Auto-Negotiation Advertisement (Register 4)	11E1 _H
STD_AN_LPA	Auto-Negotiation Link Partner Ability (Register 5)	0000 _H
STD_AN_EXP	Auto-Negotiation Expansion (Register 6)	0004 _H
STD_AN_NPTX	Auto-Negotiation Next Page Transmit Register (Register 7)	2001 _H
STD_AN_NPRX	Auto-Negotiation Link Partner Received Next Page Register (Register 8)	0000 _H
STD_GCTRL	Gigabit Control Register (Register 9)	0200 _H
STD_GSTAT	Gigabit Status Register (Register 10)	0000 _H
STD_MMDCTRL	MMD Access Control Register (Register 13)	0000 _H
STD_MMDDATA	MMD Access Data Register (Register 14)	0000 _H
STD_XSTAT	Extended Status Register (Register 15)	2000 _H

1) For the device specific reset value, refer to the Product Naming table in the [Package Outline](#) chapter.

5.1.1 Standard Management Registers

This chapter describes all registers of STD in detail.

STD Control (Register 0)

This register controls the main functions of the PHY.

IEEE Standard Register=0

STD_CTRL

STD Control (Register 0)

Reset Value

1140_H

15	14	13	12	11	10	9	8	7	6	5			0
RST	LB	SSL	ANEN	PD	ISOL	ANRS	DPLX	COL	SSM			RES	
RWSC	RW	RW	RW	RW	RW	RWSC	RW	RW	RW			RO	

Field	Bits	Type	Description
RST	15	RWSC	<p>Reset Resets the PHY to its default state. Active links are terminated. Note that this is a self-clearing bit which is set to zero by the hardware after reset has been done.</p> <p>0_B NORMAL Normal operational mode 1_B RESET Resets the device</p>
LB	14	RW	<p>Loopback on GMII This mode enables looping back of MII data from the transmit to the receive direction. No data is transmitted to the Ethernet PHY. The device operates at the selected speed. The collision signal remains de-asserted unless otherwise forced by the collision test.</p> <p>0_B NORMAL Normal operational mode 1_B ENABLE Closes the loopback from Tx to Rx at xMII</p>
SSL	13	RW	<p>Forced Speed Selection LSB This bit only takes effect with the auto-negotiation process is disabled (STD_CTRL.ANEN bit is set to 0_B). This is the lower bit (LSB) of the forced speed selection. In conjunction with the higher bit (MSB), this encoding is valid: The standard procedure to force 2500 Mbit/s operation (when ANEG is disabled) is to program PMA_CTRL with 1.0.6 = 1.0.13 = 1 and 1.0.5:2 = [0 1 1 0] PHY mirrors 1.0.6, 1.0.13 and 0.0.6, 0.0.13 MSB LSB bit values: 00_B 10 Mbit/s 01_B 100 Mbit/s 10_B 1000 Mbit/s 11_B Reserved</p>

Field	Bits	Type	Description (cont'd)
ANEN	12	RW	<p>Auto-Negotiation Enable Allows enabling and disabling of the auto-negotiation process capability of the PHY. If enabled, the force bits for duplex mode (STD_CTRL.DPLX) and the speed selection (STD_CTRL.SSM, STD_CTRL.SSL) become inactive. Otherwise, the force bits define the PHY operation.</p> <p>0_B DISABLE Disable the auto-negotiation protocol 1_B ENABLE Enable the auto-negotiation protocol</p>
PD	11	RW	<p>Power Down Forces the device into a power down state (SLEEP) in which power consumption is the minimum required to still maintain the MII management interface communication. When activating the power down functionality, the PHY terminates active data links. The MII interface is also stopped in power down mode.</p> <p>0_B NORMAL Normal operational mode 1_B POWERDOWN Forces the device into power down mode</p>
ISOL	10	RW	<p>Isolate The isolation mode isolates the PHY from the MAC. MAC interface inputs are ignored, whereas MAC interface outputs are set to tristate (high-impedance).</p> <p>0_B NORMAL Normal operational mode 1_B ISOLATE Isolates the PHY from the MAC</p>
ANRS	9	RWSC	<p>Restart Auto-Negotiation Restarts the auto-negotiation process on the MDI. This bit does not take any effect when auto-negotiation is disabled using (STD_CTRL.ANEN). Note that this bit is self-clearing after the auto-negotiation process is initiated.</p> <p>0_B NORMAL Stay in current mode 1_B RESTART Restart auto-negotiation</p>
DPLX	8	RW	<p>Forced Duplex Mode This bit controls forced duplex mode. It forces the PHY into full or half-duplex mode for 10BASE-T and 100BASE-T modes. This field is ignored for higher speeds.</p> <p>Note(s): - This bit only takes effect when the auto-negotiation process (STD_CTRL.ANEN) is set to 0_B. - This bit does not take effect in loopback mode, when STD_CTRL.LB is set to 1_B.</p> <p>0_B HD Half-duplex 1_B FD Full-duplex</p>
COL	7	RW	<p>Collision Test Allows testing of the COL signal at the xMII interface. When the collision test is enabled, the state of the TX_EN signal is looped back to the COL signal within a minimum latency.</p> <p>0_B DISABLE Normal operational mode 1_B ENABLE Activates the collision test</p>

Field	Bits	Type	Description (cont'd)
SSM	6	RW	<p>Forced Speed Selection MSB</p> <p>This bit only takes effect when the auto-negotiation process is disabled, that is, bit ANEN is set to zero.</p> <p>This is the most significant bit (MSB) of the forced speed selection. In conjunction with the lower bit, (LSB), the following encoding is valid: PHY mirrors 1.06, 1.0.13 and 0.0.6, 0.0.13</p> <p>MSB LSB:</p> <p>00_B 10 Mbit/s</p> <p>01_B 100 Mbit/s</p> <p>10_B 1000 Mbit/s</p> <p>11_B Reserved</p>
RES	5:0	RO	<p>Reserved</p> <p>Write as zero, ignore on read.</p>

Status Register (Register 1)

This register contains status and capability information about the device. All bits are read-only. A write access by the MAC does not have any effect.

IEEE Standard Register=1

STD_STAT

Reset Value

Status Register (Register 1)

7949_H

15	14	13	12	11	10	9	8	7	6	5	4	3	2	1	0	
CBT4	CBTX F	CBTX H	XBTF	XBTH	CBT2F	CBT2 H	EXT	RES	MFPS	ANOK	RF	ANAB	LS	JD	XCAP	
ro	ro	ro	ro	ro	ro	ro	ro	ro	ro	ro	ro	rolh	ro	roll	rolh	ro

Field	Bits	Type	Description
CBT4	15	RO	IEEE 100BASE-T4 Specifies the 100BASE-T4 ability. 0 _B DISABLED PHY does not support this mode 1 _B ENABLED PHY supports this mode
CBTXF	14	RO	IEEE 100BASE-TX Full-Duplex Specifies the 100BASE-TX full-duplex ability. 0 _B DISABLED PHY does not support this mode 1 _B ENABLED PHY supports this mode
CBTXH	13	RO	IEEE 100BASE-TX Half-Duplex Specifies the 100BASE-TX half-duplex ability. 0 _B DISABLED PHY does not support this mode 1 _B ENABLED PHY supports this mode
XBTF	12	RO	IEEE 10BASE-T Full-Duplex Specifies the 10BASE-T full-duplex ability. 0 _B DISABLED PHY does not support this mode 1 _B ENABLED PHY supports this mode
XBTH	11	RO	IEEE 10BASE-T Half-Duplex Specifies the 10BASE-T half-duplex ability. 0 _B DISABLED PHY does not support this mode 1 _B ENABLED PHY supports this mode
CBT2F	10	RO	IEEE 100BASE-T2 Full-Duplex Specifies the 100BASE-T2 full-duplex ability. 0 _B DISABLED PHY does not support this mode 1 _B ENABLED PHY supports this mode
CBT2H	9	RO	IEEE 100BASE-T2 Half-Duplex Specifies the 100BASE-T2 half-duplex ability. 0 _B DISABLED PHY does not support this mode 1 _B ENABLED PHY supports this mode

Field	Bits	Type	Description (cont'd)
EXT	8	RO	Extended Status The extended status registers are used to specify 1000 Mbit/s speed capabilities in the register STD_XSTAT register. 0 _B DISABLED No extended status information available in register 15 1 _B ENABLED Extended status information available in register 15
RES	7	RO	Reserved Ignore when read.
MFPS	6	RO	Management Preamble Suppression Specifies the MF preamble suppression ability. 0 _B DISABLED PHY requires management frames with preamble 1 _B ENABLED PHY accepts management frames without preamble
ANOK	5	RO	Auto-Negotiation Completed Indicates whether the auto-negotiation process is completed or in progress. 0 _B RUNNING Auto-Negotiation process is in progress 1 _B COMPLETED Auto-Negotiation process is completed
RF	4	ROLH	Remote Fault Indicates the detection of a remote fault event. 0 _B INACTIVE No remote fault condition detected 1 _B ACTIVE Remote fault condition detected
ANAB	3	RO	Auto-Negotiation Ability Specifies the auto-negotiation ability. 0 _B DISABLED PHY is not able to perform auto-negotiation 1 _B ENABLED PHY is able to perform auto-negotiation
LS	2	ROLL	Link Status Indicates the link status of the PHY to the link partner. 0 _B INACTIVE The link is down. No communication with link partner possible. 1 _B ACTIVE The link is up. Data communication with link partner is possible.
JD	1	ROLH	Jabber Detect Indicates that a jabber event has been detected. 0 _B NONE No jabber condition detected 1 _B DETECTED Jabber condition detected
XCAP	0	RO	Extended Capability Indicates the availability and support of extended capability registers. 0 _B DISABLED Only base registers are supported 1 _B ENABLED Extended capability registers are supported

PHY Identifier 1 (Register 2)

This code specifies the Organizationally Unique Identifier (OUI), the vendor's model number, and the model's revision number.

IEEE Standard Register=2

STD_PHYID1

Reset Value

PHY Identifier 1 (Register 2)

C133_H

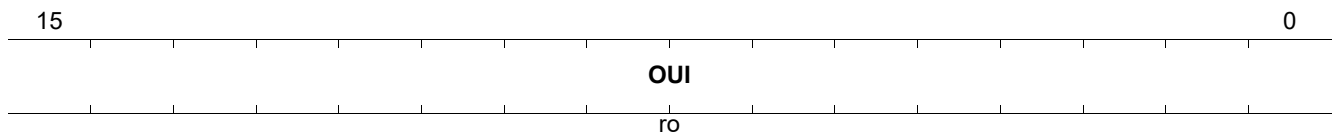

Field	Bits	Type	Description
OUI	15:0	RO	Organizationally Unique Identifier Bits 3:18

PHY Identifier 2 (Register 3)

IEEE Standard Register=3

STD_PHYID2

PHY Identifier 2 (Register 3)

Reset Value

5580_H



Field	Bits	Type	Description
OUI	15:10	RO	Organizationally Unique Identifier Bits 19:24
LDN	9:4	RO	Device Number Specifies the device number ¹⁾ to distinguish between several products.
LDRN	3:0	RO	Device Number Specifies the device revision number ¹⁾ to distinguish between several versions of this device.

1) For the device specific reset value, refer to Product Naming table in the [Package Outline](#) chapter.

Auto-Negotiation Advertisement (Register 4)

This register contains the advertised abilities of the PHY during auto-negotiation.

IEEE Standard Register=4

STD_AN_ADV

Reset Value

Auto-Negotiation Advertisement (Register 4)

11E1_H

15	14	13	12	11		5	4		0
NP	RES	RF	XNP		TAF			SF	
rw	ro	rw	rw		rw			rw	

Field	Bits	Type	Description
NP	15	RW	Next Page Next page indication is encoded in bit NP regardless of the selector field value or link code word encoding. The PHY always advertises NP if a 1000BASE-T mode is advertised during auto-negotiation. 0 _B INACTIVE No next page(s) will follow 1 _B ACTIVE Additional next page(s) will follow
RES	14	RO	Reserved Write as zero, ignore on read.
RF	13	RW	Remote Fault The remote fault bit allows indication of a fault to the link partner. 0 _B NONE No remote fault is indicated 1 _B FAULT A remote fault is indicated
XNP	12	RW	Extended Next Page Indicates that the PHY supports transmission of extended next pages (XNP). 0 _B UNABLE PHY is XNP unable 1 _B ABLE PHY is XNP able
TAF	11:5	RW	Technology Ability Field The technology ability field is an 8-bit wide field containing information indicating supported technologies. This field indicates PHY support for 10BASE-T (half- and full-duplex), 100BASE-T (half- and full-duplex), and PAUSE (asymmetric and symmetric). 40 _H PS_ASYM Advertise asymmetric pause 20 _H PS_SYM Advertise symmetric pause 10 _H DBT4 Advertise 100BASE-T4 08 _H DBT_FDX Advertise 100BASE-TX full-duplex 04 _H DBT_HDX Advertise 100BASE-TX half-duplex 02 _H XBT_FDX Advertise 10BASE-T full-duplex 01 _H XBT_HDX Advertise 10BASE-T half-duplex
SF	4:0	RW	Selector Field The selector field is a 5-bit wide field for encoding 32 possible messages. Combinations not specified are reserved for future use. Reserved combinations of the selector field are not to be transmitted. 00001 _B IEEE802DOT3 Select the IEEE 802.3 technology

Auto-Negotiation Link Partner Ability (Register 5)

IEEE Standard Register=5

When the auto-negotiation is complete, this register contains the advertised ability of the link partner. The bit definitions are a direct representation of the received link code word.

STD_AN_LPA

Reset Value

Auto-Negotiation Link Partner Ability (Register 5)

0000_H

15	14	13	12	11		5	4		0
NP	ACK	RF	XNP			TAF			SF
ro	ro	ro	rw			rw			ro

Field	Bits	Type	Description
NP	15	RO	Next Page Next page request indication from the link partner. 0 _B INACTIVE No next page(s) will follow 1 _B ACTIVE Additional next pages will follow
ACK	14	RO	Acknowledge Acknowledgment indication from the link partner's link code word. 0 _B INACTIVE The device did not successfully receive its link partner's link code word 1 _B ACTIVE The device has successfully received its link partner's link code word
RF	13	RO	Remote Fault Remote fault indication from the link partner. 0 _B NONE Remote fault is not indicated by the link partner 1 _B FAULT Remote fault is indicated by the link partner
XNP	12	RW	Extended Next Page Indicates that PHY supports transmission of extended next pages (XNP). 0 _B UNABLE Link partner is XNP unable 1 _B ABLE Link partner is XNP able
TAF	11:5	RW	Technology Ability Field 40 _H PS_ASYM Advertise asymmetric pause 20 _H PS_SYM Advertise symmetric pause 10 _H DBT4 Advertise 100BASE-T4 08 _H DBT_FDX Advertise 100BASE-TX full-duplex 04 _H DBT_HDX Advertise 100BASE-TX half-duplex 02 _H XBT_FDX Advertise 10BASE-T full-duplex 01 _H XBT_HDX Advertise 10BASE-T half-duplex
SF	4:0	RO	Selector Field 00001 _B IEEE802DOT3 Select the IEEE 802.3 technology

Auto-Negotiation Next Page Transmit Register (Register 7)

The auto-negotiation next page transmit register contains the next page link code word to be transmitted when next page ability is supported.

IEEE Standard Register=7

STD_AN_NPTX

Reset Value

Auto-Negotiation Next Page Transmit Register (Register 7)

2001_H

15	14	13	12	11	10											0
NP	RES	MP	ACK2	TOGG	MCF											
rw	ro	rw	rw	ro	rw											

Field	Bits	Type	Description
NP	15	RW	Next Page 0 _B INACTIVE Last page 1 _B ACTIVE Additional next page(s) will follow
RES	14	RO	Reserved Write as zeros, ignore on read.
MP	13	RW	Message Page Indicates that the content of STD_AN_NPTX.MCF is either an unformatted page or a formatted message. 0 _B UNFOR Unformatted page 1 _B MESSG Message page
ACK2	12	RW	Acknowledge 2 0 _B INACTIVE Device cannot comply with message 1 _B ACTIVE Device will comply with message
TOGG	11	RO	Toggle This bit always takes the opposite value of the STD_AN_NPTX.TOGG bit in the previously exchanged link code word. 0 _B ZERO Previous value of the transmitted link code word was 1 _B 1 _B ONE Previous value of the transmitted link code word was 0 _B

Field	Bits	Type	Description (cont'd)
MCF	10:0	RW	<p>Message or Unformatted Code Field</p> <p>When Message Page STD_AN_NPTX.MP bit is set to 1_B (0.7.13), this field is the Message Code Field of a message page used in next page exchange. The message codes are described in IEEE802.3 Appendix 28C.</p> <p>It is used to indicate the type of message in UCF1 and UCF2.</p> <p>00_H Reserved 01_H Null message 02_H One Unformatted Page (UP) with TAF follows 03_H Two UPs with TAF follows 04_H Remote fault details message 05_H OUI message 06_H PHY ID message 07_H 100BASE-T2 message 08_H 1000BASE-T message 09_H MULTIGBASE-T message 0A_H EEE technology capability follows in next UP 0B_H OUI XNP</p>

Auto-Negotiation Link Partner Received Next Page Register (Register 8)

The auto-negotiation link partner received next page register contains the next page link code word received from the link partner.

IEEE Standard Register=8

STD_AN_NPRX

Reset Value

Auto-Negotiation Link Partner Received Next Page Register (Register 8)

0000_H

15	14	13	12	11	10											0
NP	ACK	MP	ACK2	TOGG	MCF											
ro	ro	ro	ro	ro	rw											

Field	Bits	Type	Description
NP	15	RO	Next Page 0 _B INACTIVE No next pages to follow 1 _B ACTIVE Additional next page(s) will follow
ACK	14	RO	Acknowledge 0 _B INACTIVE The device did not successfully receive its link partner's link code word 1 _B ACTIVE The device has successfully received its link partner's link code word
MP	13	RO	Message Page Indicates that the content of STD_AN_NPTX.MCF is either an unformatted page or a formatted message. 0 _B UNFOR Unformatted page 1 _B MESSG Message page
ACK2	12	RO	Acknowledge 2 0 _B INACTIVE Device cannot comply with message 1 _B ACTIVE Device will comply with message
TOGG	11	RO	Toggle This bit always takes the opposite value of the TOGG bit in the previously exchanged link code word. 0 _B ZERO Previous value of the transmitted link code word was equal to ONE 1 _B ONE Previous value of the transmitted link code word was equal to ZERO

Field	Bits	Type	Description (cont'd)
MCF	10:0	RW	<p>Message or Unformatted Code Field</p> <p>This field is the Message Code Field of a message page used in next page exchange.</p> <p>The message codes are described in IEEE802.3 Appendix 28C. It is used to indicate the type of message in UCF1 and UCF2.</p> <p>00_H Reserved 01_H Null message 02_H One Unformatted Page (UP) with TAF follows 03_H Two UPs with TAF follows 04_H Remote fault details message 05_H OUI message 06_H PHY ID message 07_H 100BASE-T2 message 08_H 1000BASE-T message 09_H MULTIGBASE-T message 0A_H EEE technology capability follows in next UP 0B_H OUI XNP</p>

Gigabit Control Register (Register 9)

This is the control register used to configure the Gigabit Ethernet behavior of the PHY.

IEEE Standard Register=9

STD_GCTRL

Reset Value

Gigabit Control Register (Register 9)

0200_H

15	13	12	11	10	9	8	7				0
TM		MSEN	MS	MSPT	MBTF D	MBTH D	RES				
rw		rw	rw	rw	rw	rw	ro				

Field	Bits	Type	Description
TM	15:13	RW	Transmitter Test Mode This register field allows enabling of the standard transmitter test modes. 000 _B NOP Normal operation 001 _B WAV Test mode 1 transmit waveform test 010 _B JITM Test mode 2 transmit jitter test in master mode 011 _B JITS Test mode 3 transmit jitter test in slave mode 100 _B DIST Test mode 4 transmitter distortion test
MSEN	12	RW	Master/Slave Manual Configuration Enable 0 _B DISABLED Disable master/slave manual configuration value 1 _B ENABLED Enable master/slave manual configuration value
MS	11	RW	Master/Slave Config Value Allows forcing of master or slave mode manually when STD_GCTRL.MSEN is set to logical one. 0 _B SLAVE Configure PHY as slave during master/slave negotiation 1 _B MASTER Configure PHY as master during master/slave negotiation
MSPT	10	RW	Master/Slave Port Type Defines whether the PHY advertises itself as a multi- or single-port device, which in turn impacts the master/slave resolution function. 0 _B SPD Single-port device 1 _B MPD Multi-port device
MBTFD	9	RW	1000BASE-T Full-Duplex Advertises the 1000BASE-T full-duplex capability; always forced to 1 _B in converter mode. 0 _B DISABLED Advertise PHY as not 1000BASE-T full-duplex capable 1 _B ENABLED Advertise PHY as 1000BASE-T full-duplex capable
MBTHD	8	RW	1000BASE-T Half-Duplex Always advertises the 1000BASE-T half-duplex capability as disabled; PHY does not support 1000BASE-T Half-Duplex capability 0 _B DISABLED Advertise PHY as not 1000BASE-T half-duplex capable 1 _B ENABLED Advertise PHY as 1000BASE-T half-duplex capable

Field	Bits	Type	Description (cont'd)
RES	7:0	RO	Reserved Write as zero, ignore on read.

Gigabit Status Register (Register 10)

This is the status register used to reflect the Gigabit Ethernet status of the PHY.
IEEE Standard Register=10

STD_GSTAT

Reset Value

Gigabit Status Register (Register 10)

0000_H

15	14	13	12	11	10	9	8	7												0
MSFA ULT	MSRE S	LRXS TAT	RRXS TAT	MBTF D	MBTH D	RES			IEC											
rwsc	ro	ro	ro	ro	ro	ro			rwsc											

Field	Bits	Type	Description
MSFAULT	15	RWSC	Master/Slave Manual Configuration Fault This bit is set if the number of attempts to set the master/slave configuration reaches 7. It is cleared upon each read of the STD_GSTAT register. This bit self clears on auto-negotiation enable or auto-negotiation complete. 0 _B OK Master/slave manual configuration resolved successfully 1 _B NOK Master/slave manual configuration resolved with a fault
MSRES	14	RO	Master/Slave Configuration Resolution 0 _B SLAVE Local PHY configuration resolved to slave 1 _B MASTER Local PHY configuration resolved to master
LRXSTAT	13	RO	Local Receiver Status Indicates the status of the local receiver. 0 _B NOK Local receiver not OK 1 _B OK Local receiver OK
RRXSTAT	12	RO	Remote Receiver Status Indicates the status of the remote receiver. 0 _B NOK Remote receiver not OK 1 _B OK Remote receiver OK
MBTFD	11	RO	Link Partner Capable of Operating 1000BASE-T Full-Duplex 0 _B DISABLED Link partner is not capable of operating 1000BASE-T full-duplex 1 _B ENABLED Link partner is capable of operating 1000BASE-T full-duplex
MBTHD	10	RO	Link Partner Capable of Operating 1000BASE-T Half-Duplex 0 _B DISABLED Link partner is not capable of operating 1000BASE-T half-duplex 1 _B ENABLED Link partner is capable of operating 1000BASE-T half-duplex
RES	9:8	RO	Reserved Write as zero, ignore on read.

Field	Bits	Type	Description (cont'd)
IEC	7:0	RWSC	Idle Error Count Indicates the idle error count. This field contains a cumulative count of the errors detected when the receiver is receiving idles.

MMD Access Control Register (Register 13)

The MMD access control register is used in conjunction with the MMDDATA register to access the MMD register space. This uses address directing as specified in IEEE802.3 Clause 22 Extended.

IEEE Standard Register=13

STD_MMDCTRL

Reset Value

MMD Access Control Register (Register 13)

0000_H

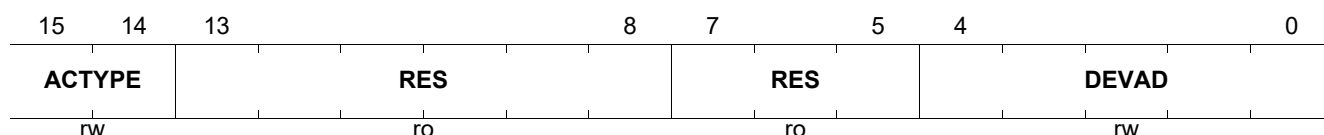

Field	Bits	Type	Description
ACTYPE	15:14	RW	Access Type Function If the access of the MMDDATA register is an address access (ACTYPE = 00 _B) then it is directed to the address register within the MMD associated with the value in the DEVAD field. Otherwise, both the DEVAD field and the MMD's address register direct the register MMDDATA data accesses to the appropriate registers within that MMD. 00 _B ADDRESS Accesses to register MMDDATA access the MMD individual address register 01 _B DATA Accesses to register MMDDATA access the register within the MMD selected 10 _B DATA_PI Accesses to register MMDDATA access the register within the MMD selected 11 _B DATA_PIWR Accesses to register MMDDATA access the register within the MMD selected
RES	13:8	RO	Reserved Write as zero, ignored on read.
RES	7:5	RO	Reserved Write as zero, ignored on read.
DEVAD	4:0	RW	Device Address The field directs any accesses of register MMDDATA to the appropriate MMD.

MMD Access Data Register (Register 14)

The MMD access data register is used in conjunction with the MMD access control (MMDCTRL) register to access the MMD register space.

IEEE Standard Register=14

STD_MMDDATA

Reset Value

MMD Access Data Register (Register 14)

0000_H

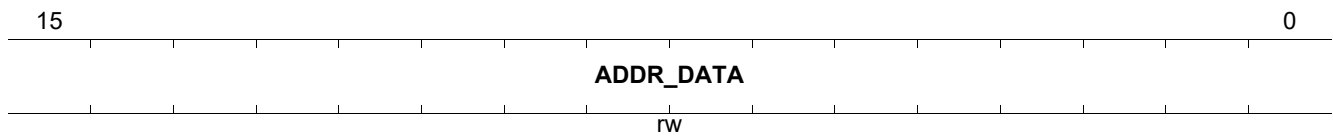

Field	Bits	Type	Description
ADDR_DATA	15:0	RW	Address or Data Register This register accesses either a specific MMD address register or the data content of the MMD register to which this address register points. Which of the functions is currently valid is defined by the MMDCTRL register.

Extended Status Register (Register 15)

This register contains extended status and capability information about the PHY. All bits are read-only. A write access does not have any effect.

IEEE Standard Register=15

STD_XSTAT

Reset Value

Extended Status Register (Register 15)

2000_H

15	14	13	12	11	8	7	0
MBXF	MBXH	MBTF	MBTH	RES			RES
ro	ro	ro	ro	ro			ro

Field	Bits	Type	Description
MBXF	15	RO	1000BASE-X Full-Duplex Capability Specifies whether the PHY is capable of operating 1000BASE-X full-duplex. 0 _B DISABLED PHY does not support this mode 1 _B ENABLED PHY supports this mode
MBXH	14	RO	1000BASE-X Half-Duplex Capability Specifies whether the PHY is capable of operating 1000BASE-X half-duplex. 0 _B DISABLED PHY does not support this mode 1 _B ENABLED PHY supports this mode
MBTF	13	RO	1000BASE-T Full-Duplex Capability Specifies whether the PHY is capable of operating 1000BASE-T full-duplex. 0 _B DISABLED PHY does not support this mode 1 _B ENABLED PHY supports this mode
MBTH	12	RO	1000BASE-T Half-Duplex Capability PHY does not support 1000BASE-T Half-Duplex capability. 0 _B DISABLED PHY does not support this mode 1 _B ENABLED PHY supports this mode
RES	11:8	RO	Reserved Ignore when read.
RES	7:0	RO	Reserved Ignore when read.

5.2 PHY-specific Management Registers

This section describes the PHY specific management registers.

Table 16 Registers Overview - PHY-specific Management Registers

Register Short Name	Register Long Name	Reset Value
PHY_CTL	PHY Specific Function Control Register (Register 16)	0062 _H
PHY_STAT	PHY Specific Status (Register 17)	0000 _H
PHY_IMASK	Interrupt Mask Register (Register 18)	0000 _H
PHY_ISTAT	Interrupt Status Register (Register 19)	0000 _H
PHY_ADS_CTL	Speed Auto Downgrade Control Register (Register 20)	0082 _{C_H}
PHY_EXT_ADR	Extended Register's Address Offset Register (Register 30)	0000 _H
PHY_EXT_DATA	Extended Register's Data Register (Register 31)	1C8D _H

5.2.2 PHY Specific Status Register (Register 17)

This section describes the PHY Specific Status register in detail.

PHY Specific Status Register (Register 17)

The register reports PHY link, MDI crossover, polarity, ADS, and PAUSE status.

PHY_STAT	Offset	Reset Value
PHY Specific Status Register (Register 17)	0011 _H	0000 _H
15 14 13 12 11 10 9 7 6 5 4 3 2 1 0		
SPEED DPX PAGE SDR LSRT RES MDIXS ADS RES TPS RPS POLR T JABR T		
ro ro ro ro ro ro ro ro ro ro ro ro ro ro ro		

Field	Bits	Type	Description
SPEED	15:14	RO	Speed Mode This register contains the speed mode status. These status bits are only valid when PHY_STAT.SDR is 1 _B . PHY_STAT.SDR is set when auto-negotiation is completed or auto-negotiation is disabled. 00 _B 10 Mbit/s 01 _B 100 Mbit/s 10 _B 1000 Mbit/s 11 _B Reserved
DPX	13	RO	Duplex This register contains the duplex mode status. These status bits are only valid when PHY_STAT.SDR is 1 _B . PHY_STAT.SDR is set when auto-negotiation is completed or auto-negotiation is disabled. 0 _B Half-duplex 1 _B Full-duplex
PAGE	12	RO	Page Received Real-Time 0 _B Page not received 1 _B Page received
SDR	11	RO	Speed and Duplex Resolved This field contains the status of whether the speed and duplex has been resolved. This bit is set when auto-negotiation is completed or disabled. When auto-negotiation is disabled (force-speed mode), this bit is set to 1 _B . 0 _B Not resolved 1 _B Resolved
LSRT	10	RO	Link Status Real-Time 0 _B Link down 1 _B Link up
RES	9:7	RO	Reserved

Field	Bits	Type	Description (cont'd)
MDIXS	6	RO	<p>MDI Crossover Status</p> <p>This field contains the MDI Crossover status. This bit value depends upon the PHY_CTL.MDIX (bits [6:5]) configuration.</p> <p>This status bit is only valid when the PHY_STAT.SPEED is 1_B.</p> <p>0_B MDI 1_B MDIX</p>
ADS	5	RO	<p>Wirespeed Downgrade</p> <p>0_B No Downgrade 1_B Downgrade</p>
RES	4	RO	Reserved
TPS	3	RO	<p>Transmit Pause</p> <p>This field contains the MAC pause resolution status. This bit is for information purposes only.</p> <p>When in forced mode, this bit is set to 0_B. This status bit is only valid when the PHY_STAT.SPEED is 1_B.</p> <p>0_B Transmit pause disabled 1_B Transmit pause enabled</p>
RPS	2	RO	<p>Receive Pause</p> <p>This field contains the MAC pause resolution status. This bit is for information purposes only.</p> <p>When in forced mode, this bit is set to 0_B. This status bit is only valid when the PHY_STAT.SPEED is 1_B.</p> <p>0_B Receive pause disabled 1_B Receive pause enabled</p>
POLRT	1	RO	<p>Polarity Real Time</p> <p>0_B Normal polarity 1_B Reverted polarity</p>
JABRT	0	RO	<p>Jabber Real Time</p> <p>0_B No jabber 1_B Jabber</p>

5.2.3 Interrupt Mask Register (Register 18)

This section describes the Interrupt Mask Register in detail.

Interrupt Mask Register (Register 18)

This register defines the mask for the Interrupt Status Register, which contains the event source for INT_N sent from the PHY to an external device.

PHY_IMASK														Offset		Reset Value			
Interrupt Mask Register (Register 18)														0012 _H		0000 _H			
15	14	13	12	11	10	9	8	7	6	5	4	3	2	1	0				
ANE	LSPC	DXMC	NPRX	LFST	LSTC	RES			WOL	ADSC	RES	RES	RES	MDIPC	JAB				
rw	rw	rw	rw	rw	rw	rw			rw	rw	rw	rw	rw	rw	rw				

Field	Bits	Type	Description
ANE	15	RW	Auto-Negotiation Error INT Mask 0 _B Interrupt disable 1 _B Interrupt enable
LSPC	14	RW	Speed Changed INT Mask 0 _B Interrupt disable 1 _B Interrupt enable
DXMC	13	RW	Duplex Changed INT Mask 0 _B Interrupt disable 1 _B Interrupt enable
NPRX	12	RW	Page Received INT Mask 0 _B Interrupt disable 1 _B Interrupt enable
LFST	11	RW	Link Failed INT Mask 0 _B Interrupt disable 1 _B Interrupt enable
LSTC	10	RW	Link Succeed INT Mask 0 _B Interrupt disable 1 _B Interrupt enable
RES	9:7	RW	Reserved Not used.
WOL	6	RW	WOL INT Mask 0 _B Interrupt disable 1 _B Interrupt enable
ADSC	5	RW	Link Speed Auto-Downspeed Detect Mask 0 _B Interrupt disable 1 _B Interrupt enable
RES	4	RW	Reserved Not used.
RES	3	RW	Reserved

Field	Bits	Type	Description (cont'd)
RES	2	RW	Reserved
MDIPC	1	RW	Polarity Changed INT Mask 0 _B Interrupt disable 1 _B Interrupt enable
JAB	0	RW	Jabber Occurred INT Mask 0 _B Interrupt disable 1 _B Interrupt enable

5.2.4 Interrupt Status Register (Register 19)

This section describes the Interrupt Status Register in detail.

Interrupt Status Register (Register 19)

This register defines the event source for the MDINT interrupt sent from the PHY to an external device. The register is a cleared on read by the STA.

PHY_ISTAT **Offset**
Interrupt Status Register (Register 19) **0013_H** **Reset Value**
0000_H

15	14	13	12	11	10	9	8	7	6	5	4	3	2	1	0
ANE	LSPC	DXMC	NPRX	LFST	LSTC	RES	RES	RES	WOL	ADSC	RES	RES	RES	MDIPC	JAB
ro rc	ro rc	ro rc	ro rc	ro rc	ro rc	ro rc	ro rc	ro rc	ro rc	ro rc	ro rc	ro rc	ro rc	ro rc	ro rc

Field	Bits	Type	Description
ANE	15	RO RC	Auto-Negotiation Error INT This field indicates errors occurring during ANEG. 0 _B No auto-negotiation error takes place 1 _B Auto-Negotiation error takes place
LSPC	14	RO RC	Speed Changed INT 0 _B Speed not changed 1 _B Speed changed
DXMC	13	RO RC	Duplex Changed INT 0 _B Duplex not changed 1 _B Duplex changed
NPRX	12	RO RC	Page Received INT 0 _B Page not received 1 _B Page received
LFST	11	RO RC	Link Failed INT 0 _B No link down takes place 1 _B PHY link down takes place
LSTC	10	RO RC	Link Succeed INT 0 _B No link up takes place 1 _B PHY link up takes place
RES	9	RO RC	Reserved
RES	8	RO RC	Reserved
RES	7	RO RC	Reserved
WOL	6	RO RC	WOL INT 0 _B PHY did not receive WOL magic frame 1 _B PHY received WOL magic frame.
ADSC	5	RO RC	Link Speed Auto-Downspeed Detect Interrupt Status 0 _B Speed did not downgrade 1 _B Speed downgraded
RES	4	RO RC	Reserved

Field	Bits	Type	Description (cont'd)
RES	3	RO RC	Reserved
RES	2	RO RC	Reserved
MDIPC	1	RO RC	Polarity Changed INT 0 _B PHY did not revert MDI polarity 1 _B PHY revered MDI polarity
JAB	0	RO RC	Jabber Occurred INT Refer to STD_STAT.JD. 0 _B 10BaseT Tx jabber did not occur 1 _B 10BaseT Tx jabber occurred

5.2.5 Speed Auto Downgrade Control Register (Register 20)

This section describes the Speed Auto Downgrade Control Register in detail.

Speed Auto Downgrade Control Register (Register 20)

The register is used for speed downshift control.

PHY_ADS_CTL	Offset	Reset Value
Speed Auto Downgrade Control Register (Register 20)	0014_H	0082_{C_H}

15	12	11	10	9	8	7	6	5	4	2	1	0
RES		EML	REANEG	RANEG	DGA	RES		EADS	ADSRT		BAT	RES
ro		rw	rwsc	rw	rw	ro		rw	rw		rw	ro

Field	Bits	Type	Description
RES	15:12	RO	Reserved
EML	11	RW	MDIO Latch Enable 0 _B Do not latch the MII/MMD register's read out value during MDIO read 1 _B Latch the MII/MMD register's read out value during MDIO read
REANEG	10	RWSC	Restart Auto-Negotiation This field controls whether to force the PHY to restart the auto-negotiation process. 0 _B Normal state 1 _B Trigger restarting ANEG that automatically resets to 0 when auto-negotiation is complete.
RANEG	9	RW	Reverse Auto-Negotiation 0 _B Normal autoneg direction 1 _B Reverse the autoneg direction, 10 Mbit/s has 1st priority, then 100 Mbit/s and at last 1000 Mbit/s.
DGA	8	RW	Gigabit Capability Disable 0 _B Do not disable so that the PHY advertises Gigabit capability based on the STD_GCTRL. 1 _B Disable advertisement of Gigabit ability in AUTONEG.
RES	7:6	RO	Reserved
EADS	5	RW	Auto Down Speed Enable Link speed auto-downspeed is a functionality which allows an Ethernet link to be established even in non-standard harsh cable environments. This field only takes effect after a software reset. 0 _B Disabled 1 _B Enabled

Field	Bits	Type	Description (cont'd)
ADSRT	4:2	RW	<p>Autoneg Retry Limit Pre-downgrade</p> <p>This field sets the number of link-up attempts before performing an Automatic-Downspeed (ADS) of the link. For example, with a 000_B setting, the PHY makes two attempts to link-up before trying a lower speed. (N+2).</p> <p>000_B ADS after 2 consecutive link-up failures. 001_B ADS after 3 consecutive link-up failures. 010_B ADS after 4 consecutive link-up failures. 011_B ADS after 5 consecutive link-up failures. 100_B ADS after 6 consecutive link-up failures. 101_B ADS after 7 consecutive link-up failures. 110_B ADS after 8 consecutive link-up failures. 111_B ADS after 9 consecutive link-up failures.</p>
BAT	1	RW	<p>Bypass Autospeed Timer</p> <p>A link up that does not hold for 2.5 seconds is counted as a link fail, and the Auto-Downspeed retry counter increases by 1. The field only takes effect after a software reset.</p> <p>0_B Do not bypass the timer 1_B Bypass the timer</p>
RES	0	RO	Reserved

5.2.6 Extended Register's Address Offset Register (Register 30)

This section describes the Extended Register's Address Offset Register in detail.

Extended Register's Address Offset Register (Register 30)

The register is used in conjunction with the MDIO access to the extended register address field. This uses address directing as specified in the extended register chapter. See [Section 7.1](#) for more information.

PHY_EXT_ADR	Offset	Reset Value
Extended Register's Address Offset Register (Register 30)	001E _H	0000 _H
15		0
EXTA		
rw		

Field	Bits	Type	Description
EXTA	15:0	RW	Extended Register Address Offset This is the address offset of the extended register that is read or written.

5.2.7 Extended Register's Data Register (Register 31)

This section describes the Extended Register's Data Register in detail.

Extended Register's Data Register (Register 31)

The register is used in conjunction with the MDIO access to the extended data field. The data format is defined as specified in the extended register chapter. This register holds the data to be written or read to the extended register (indicated in [Section 5.2.6](#)). See [Section 7.1](#) for more information.

PHY_EXT_DATA	Offset	Reset Value
Extended Register's Data Register (Register 31)	001F _H	1C8D _H
15		0
EXTD		
rw		

Field	Bits	Type	Description
EXTD	15:0	RW	Extended Register Data This field contains the data to be written to, or read from, the extended register indicated by Extended Register Address Offset 001E _H .

6 MMD Registers Detailed Description

Table 17 MMD Register Access Type

Mode	Symbol
Status Register (Status, or Ability Register)	RO
Read-Write Register (e.g. MDIO Register)	RW
Read-Write, Self-Clearing Register. The bit is cleared after being read from the MDIO interface.	RWSC

6.1 Standard PCS Registers for MMD=0003_H

This section describes the PCS registers for MMD device 0003_H.

Table 18 Registers Overview - Standard PCS Registers

Register Short Name	Register Long Name	Reset Value
PCS_STAT1	PCS status 1 (Register 3.1)	0000 _H
PCS_EEE_CAP	PCS EEE capability (Register 3.20)	0006 _H

6.1.1 Standard PCS Registers for MMD=0003_H

This chapter describes all registers of PCS in detail.

PCS status 1 (Register 3.1)

IEEE Standard Register=3.1

PCS_STAT1

PCS status 1 (Register 3.1)

Reset Value

0000_H

15	12	11	10	9	8	7	6	5	3	2	1	0	
RES			TX_LP I*	RX_LP I*	TX_LP I*	RX_LP I*	FAUL T	TXCK ST	RES		PCS_ RX_*	LOW_ POW*	RES
ro			ro	ro	ro	ro	ro	ro	ro		ro	ro	ro

Field	Bits	Type	Description
RES	15:12	RO	Reserved
TX_LPI_RXD	11	RO	Tx Low Power Idle (LPI) Received 0 _B LPI not received 1 _B Tx PCS has received LPI
RX_LPI_RXD	10	RO	Rx LPI received 0 _B LPI not received Rx 1 _B PCS has received LPI
TX_LPI_INDICATION	9	RO	Tx LPI Indication 0 _B PCS is not currently receiving LPI 1 _B Tx PCS is currently receiving LPI
RX_LPI_INDICATION	8	RO	Rx LPI Indication 0 _B PCS is not currently receiving LPI 1 _B Rx PCS is currently receiving LPI
FAULT	7	RO	Fault 0 _B No fault condition detected 1 _B Fault condition detected
TXCKST	6	RO	Clock Stop Capable 0 _B Clock not stoppable 1 _B The MAC has the ability to stop the clock during LPI
RES	5:3	RO	Reserved
PCS_RX_LINK_STATUS	2	RO	PCS Receive Link Status 0 _B PCS receive link down 1 _B PCS receive link up
LOW_POWER_ABILITY	1	RO	Low-Power Ability 0 _B PCS does not support low-power mode 1 _B PCS supports low-power mode
RES	0	RO	Reserved

6.2 Standard Auto-Negotiation Registers for MMD=0007_H

This register file contains the auto-negotiation registers for MMD device 0007_H.

Table 19 Registers Overview - Standard Auto-Negotiation Registers

Register Short Name	Register Long Name	Reset Value
ANEG_EEE_AN_ADV1	EEE Advertisement 1 (Register 7.60)	0000 _H
ANEG_EEE_AN_LPAB1	EEE Link Partner Ability 1 (Register 7.61)	0000 _H

6.2.1 Standard Auto-Negotiation Registers for MMD=0007_H

This section describes all registers of ANEG in detail.

EEE Advertisement 1 (Register 7.60)

IEEE Standard Register=7.60

ANEG_EEE_AN_ADV1

EEE Advertisement 1 (Register 7.60)

Reset Value

0000_H

15	7	6	5	4	3	2	1	0					
RES							EEE_1 0G*	EEE_1 0G*	EEE_1 00*	EEE_1 0G*	EEE_1 00*	EEE_1 00*	RES
ro							ro	ro	ro	ro	rw	rw	ro

Field	Bits	Type	Description
RES	15:7	RO	Reserved
EEE_10GBKR	6	RO	Support of 10GBASE-KR EEE 0 _B DISABLED This PHY mode is not supported for EEE 1 _B ENABLE This PHY mode is supported for EEE
EEE_10GBKX 4	5	RO	Support of 10GBASE-KX4 EEE 0 _B DISABLED This PHY mode is not supported for EEE 1 _B ENABLE This PHY mode is supported for EEE
EEE_1000BKX	4	RO	Support of 1000BASE-KX EEE 0 _B DISABLED This PHY mode is not supported for EEE 1 _B ENABLE This PHY mode is supported for EEE
EEE_10GBT	3	RO	Support of 10GBASE-T EEE 0 _B DISABLED This PHY mode is not supported for EEE 1 _B ENABLE This PHY mode is supported for EEE
EEE_1000BT	2	RW	Support of 1000BASE-T EEE 0 _B DISABLED This PHY mode is not supported for EEE 1 _B ENABLE This PHY mode is supported for EEE
EEE_100BTX	1	RW	Support of 100BASE-TX EEE 0 _B DISABLED This PHY mode is not supported for EEE 1 _B ENABLE This PHY mode is supported for EEE
RES	0	RO	Reserved

7 Extended Register Detailed Description

Table 20 Extended Register Access Type

Mode	Symbol
Status Register (Status, or Ability Register)	RO
Read-Write Register (e.g. MDIO Register)	RW
Read-Write, Self-Clearing Register. The bit is cleared after being read from the MDIO interface.	RWSC

7.1 Common Extended Register

This section describes the common extended registers.

Table 21 Registers Overview - Common Extended Register

Register Short Name	Register Long Name	Reset Value
COM_EXT_CHIP_CFG	Chip Configuration Register (Register A001H)	8140 _H
COM_EXT_RGMII_CFG1	RGMII Configuration Register 1 (Register A003H)	00F1 _H
COM_EXT_RGMII_CFG2	RGMII Configuration Register 2 (Register A004H)	0000 _H
COM_EXT_RGMII_MDIO_CFG	RGMII In-Band Status and MDIO Configuration Register (Register A005H)	00C0 _H
COM_EXT_MISC_CFG	Miscellaneous Control Register (Register A006H)	000D _H
COM_EXT_MAC_ADDR_CFG1	Wake on LAN Address Byte 5 and 6 (Register A007H)	0000 _H
COM_EXT_MAC_ADDR_CFG2	Wake on LAN Address Byte 3 and 2 (Register A008H)	0000 _H
COM_EXT_MAC_ADDR_CFG3	Wake on LAN Address Byte 1 and 0 (Register A009H)	0000 _H
COM_EXT_WOL_CFG	Wake on LAN Control Register (Register A00AH)	0002 _H
COM_EXT_LED_GEN_CFG	LED General Configuration Register (Register A00BH)	E000 _H
COM_EXT_LED0_CFG	LED0 Configuration Register (Register A00CH)	0610 _H
COM_EXT_LED1_CFG	LED1 Configuration Register (Register A00DH)	0620 _H
COM_EXT_LED2_CFG	LED2 Configuration Register (Register A00EH)	0640 _H
COM_EXT_LED_BLINK_CFG	LED Blinking Configuration Register (Register A00FH)	0006 _H
COM_EXT_PAD_STR_CFG	Pin Driving Strength Configuration Register (Register A010H)	6BFF _H
COM_EXT_SYNC_E_CFG	SyncE Configuration Register (Register A012H)	00C8 _H

7.1.1 Chip Configuration Register (Register A001_H)

This section describes the Chip Configuration Register in detail.

Chip Configuration Register (Register A001_H)

This register controls the chip mode and configuration.

COM_EXT_CHIP_CFG	Offset	Reset Value
Chip Configuration Register (Register A001H)	A001 _H	8140 _H

15	14	10	9	8	7	6	5	4	3	2	0
MCR	RES			GERXC	RXDLY	RES	ELDO	CLDO	RES	RES	
RWSC	RW			RW	RW	RO	RW	RW	RO	RW	

Field	Bits	Type	Description
MCR	15	RWSC	Software Reset Mode This MCR field resets the chip to change the mode. The bit is active low and self clearing. 0 _B Reset 1 _B No Reset (Default)
RES	14:10	RW	Reserved
GERXC	9	RW	RGMII Rx Clock Enable This GERXC field enables or disables the RGMII Rx clock no matter the link status of the TPI. 0 _B Disable the RGMII Rx clock when the link is down. (Default) 1 _B Enable the RGMII Rx clock when the link is down.
RXDLY	8	RW	RGMII TX Clock Delay This RXDLY field enables or disables the RGMII Rx clock delay. When enabled the delay is 2 ns for 125 MHz or 8 ns for 25 MHz and 2.5 MHz. The initial setting is defined by pin strapping. 0 _B Disable the RGMII Rx clock delay. 1 _B Enable the RGMII Rx clock delay. (Default)
RES	7	RO	Reserved
ELDO	6	RW	LDO Enable This ELDO field controls the RGMII LDO. Default is 0 and is set to 1 after power-on pin strapping is completed. 0 _B Disable the LDO. 1 _B Enable the LDO. (Default)
CLDO	5:4	RW	LDO Configuration This CLDO field sets the RGMII LDO voltage and RGMII/MDC/MDIO pin's level shifter control. The initial setting is defined by pin strapping. 00 _B 3.3 V - Not regulated from 3.3 V. (Default) 01 _B 2.5 V 10 _B 1.8 V 11 _B 1.8 V

Field	Bits	Type	Description (cont'd)
RES	3	RO	Reserved
RES	2:0	RW	Reserved

7.1.2 RGMII Configuration Register 1 (Register A003_H)

This section describes the RGMII Configuration Register 1 in detail.

RGMII Configuration Register 1 (Register A003_H)

This register controls the setting of RGMII interface.

COM_EXT_RGMII_CFG1	Offset	Reset Value
RGMII Configuration Register 1 (Register A003H)	A003 _H	00F1 _H

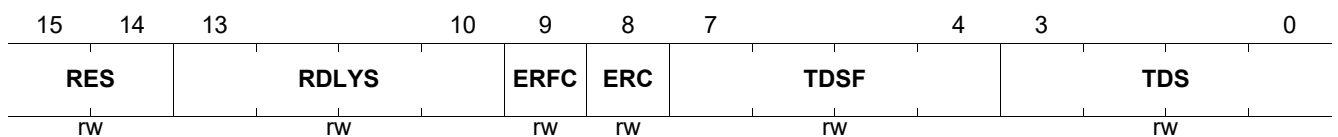

Field	Bits	Type	Description
RES	15:14	RW	Reserved
RDLYS	13:10	RW	RGMII Rx Delay Select This register controls the RGMII Rx clock delay training configuration. Each step adds approximately 150 ps of delay. 0000 _B Disabled (Default) 0001 _B 150 ps 0010 _B 300 ps 0011 _B 450 ps 0100 _B 600 ps 0101 _B 750 ps 0110 _B 900 ps 0111 _B 1050 ps 1000 _B 1200 ps 1001 _B 1350 ps 1010 _B 1500 ps 1011 _B 1650 ps 1100 _B 1800 ps 1101 _B 1950 ps 1110 _B 2100 ps 1111 _B 2250 ps
ERFC	9	RW	Enable RGMII In-Band Full Duplex with CRS This ERFC field in conjunction with the ERC field controls encoding of the GMII/MII CRS into RGMII In-band status. 0 _B Encoding of GMII/MII CRS into RGMII In-band status is controlled by the ERC field. (Default) 1 _B Encode GMII/MII CRS into RGMII In-band status if the field ERC is set to 1.

Field	Bits	Type	Description (cont'd)
ERC	8	RW	<p>Enable RGMII In-Band with CRS</p> <p>This ERC field controls encoding of GMII/MII CRS into RGMII In-band status.</p> <p>0_B Do not encode GMII/MII CRS into RGMII In-band status. (Default)</p> <p>1_B Encode GMII/MII CRS into RGMII In-band status on half-duplex mode or if field ERFC is also set to 1.</p>
TDSF	7:4	RW	<p>Fast Ethernet RGMII Tx Clock Delay Selection</p> <p>This TDSF field configures the RGMII TX_CLK delay train for 100 Mbps or 10 Mbps link speed. Each step delays by about 150 ps.</p> <p>0000_B Disabled</p> <p>0001_B 150 ps</p> <p>0010_B 300 ps</p> <p>0011_B 450 ps</p> <p>0100_B 600 ps</p> <p>0101_B 750 ps</p> <p>0110_B 900 ps</p> <p>0111_B 1050 ps</p> <p>1000_B 1200 ps</p> <p>1001_B 1350 ps</p> <p>1010_B 1500 ps</p> <p>1011_B 1650 ps</p> <p>1100_B 1800 ps</p> <p>1101_B 1950 ps</p> <p>1110_B 2100 ps</p> <p>1111_B 2250 ps (Default)</p>
TDS	3:0	RW	<p>Gigabit Ethernet RGMII Tx Clock Delay Selection</p> <p>This TDS field configures the RGMII TX_CLK delay train for 1000 Mbps link speed. Each step delays by about 150 ps.</p> <p>0000_B Disabled</p> <p>0001_B 150 ps (Default)</p> <p>0010_B 300 ps</p> <p>0011_B 450 ps</p> <p>0100_B 600 ps</p> <p>0101_B 750 ps</p> <p>0110_B 900 ps</p> <p>0111_B 1050 ps</p> <p>1000_B 1200 ps</p> <p>1001_B 1350 ps</p> <p>1010_B 1500 ps</p> <p>1011_B 1650 ps</p> <p>1100_B 1800 ps</p> <p>1101_B 1950 ps</p> <p>1110_B 2100 ps</p> <p>1111_B 2250 ps</p>

7.1.3 RGMII Configuration Register 2 (Register A004_H)

This section describes the RGMII Configuration Register 2 in detail.

RGMII Configuration Register 2 (Register A004_H)

This register is used for RGMII in-band status.

COM_EXT_RGMII_CFG2	Offset	Reset Value
RGMII Configuration Register 2 (Register A004_H)	A004_H	0000_H

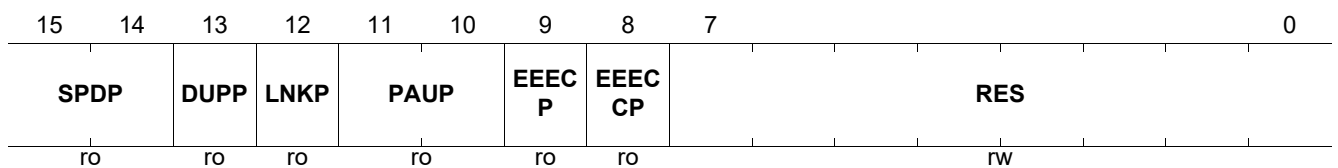

Field	Bits	Type	Description
SPDP	15:14	RO	RGMII PHY Speed Status This SPDP field reports the RGMII interface speed information when configured as an RGMII PHY. This is also the source of RGMII In-band status communication. 00 _B 10 Mbps (Default) 01 _B 100 Mbps 10 _B 1000 Mbps 11 _B Reserved
DUPP	13	RO	RGMII PHY Duplex Status This DUPP field reports the RGMII interface duplex information when configured as an RGMII PHY. This is also the source of RGMII In-band status. 0 _B Half-duplex (Default) 1 _B Full-duplex
LNKP	12	RO	RGMII PHY Link-up Status This LNKP field reports the RGMII interface linkup information when configured as an RGMII PHY. This is also the source of RGMII In-band status. 0 _B Link down (Default) 1 _B Link up
PAUP	11:10	RO	RGMII PHY Pause Information This PAUP field reports the RGMII interface pause information when configured as an RGMII PHY. 00 _B No asymmetric pause (Default) 10 _B Asymmetric pause 01 _B No Pause symmetric pause 11 _B Symmetric pause

Field	Bits	Type	Description (cont'd)
EEEECP	9	RO	<p>RGMII PHY EEE Capability</p> <p>This EEECP field reports the capability of the RGMII interface for EEE when configured as RGMII PHY.</p> <p>0_B This RGMII interface is not capable of EEE. (Default)</p> <p>1_B This RGMII interface is capable of EEE.</p>
EEEECCP	8	RO	<p>RGMII PHY EEE Clock Stopping</p> <p>This EEECCP field reports the capability of the RGMII interface for EEE clock stopping when configured as RGMII PHY.</p> <p>0_B This RGMII interface is not capable of EEE clock stopping. (Default)</p> <p>1_B This RGMII interface is capable of EEE clock stopping.</p>
RES	7:0	RW	Reserved

7.1.4 RGMII In-Band Status and MDIO Configuration Register (Register A005_H)

This section describes the RGMII In-Band Status and MDIO Configuration Register in detail.

RGMII In-Band Status and MDIO Configuration Register (Register A005_H)

This register shows the RGMII in-band status and MDIO setting.

COM_EXT_RGMII_MDIO_CFG	Offset	Reset Value
RGMII In-Band Status and MDIO Configuration Register (Register A005H)	A005_H	00C0_H

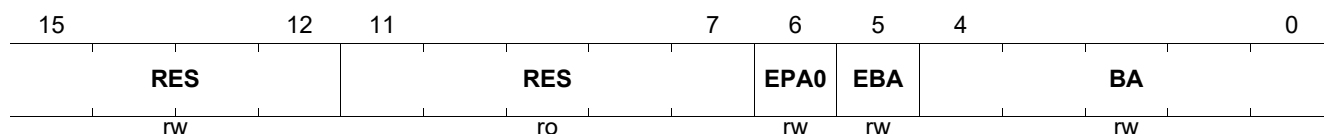

Field	Bits	Type	Description
RES	15:12	RW	Reserved
RES	11:7	RO	Reserved Reserved The default is 0 _B .
EPA0	6	RW	Enable PHY Address 0 Broadcast Responses This field controls whether the PHY responds to the MDIO interface's broadcasts access from PHY address 0. 0 _B Disabled 1 _B Enabled (Default)
EBA	5	RW	Enable PHY BA Broadcast Responses This field controls whether the PHY responds to broadcasts from a PHY address defined in COM_ETX_RGMII_MIDO_CFG.BA . 0 _B Disabled 1 _B Enabled (Default)
BA	4:0	RW	Broadcast Address This BA field defines the address for accepting broadcast access response. The default is 0 _B .

7.1.5 Miscellaneous Control Register (Register A006_H)

This section describes the Miscellaneous Control Register in detail.

Miscellaneous Control Register (Register A006_H)

This register controls miscellaneous PHY settings.

COM_EXT_MISC_CFG	Offset	Reset Value
Miscellaneous Control Register (Register A006 _H)	A006 _H	000D _H

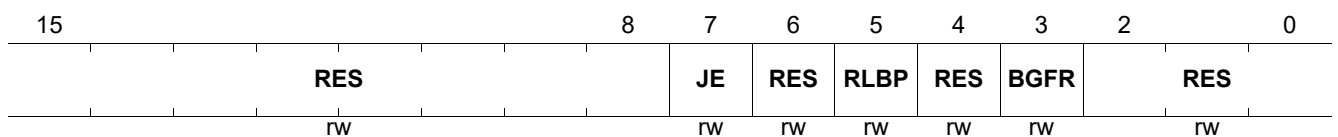

Field	Bits	Type	Description
RES	15:8	RW	Reserved
JE	7	RW	Jumbo Frame Enable This JE field controls the use of jumbo frames. 0 _B Jumbo frames are disabled. (Default) 1 _B Jumbo frames are enabled.
RES	6	RW	Reserved
RLBP	5	RW	PHY Remote Loopback This RLBP field controls setting of remote loopback for PHY. 0 _B Disabled (Default) 1 _B Enabled
RES	4	RW	Reserved
BGFR	3	RW	Bypass GMII Overflow and Reset This BGFR field controls whether to bypass the GMII FIFO overflow and underflow RST. 0 _B Enable to reset GMII FIFO automatic when overflow or underflow happens. 1 _B Disable to reset GMII FIFO when overflow or underflow happen. (Default)
RES	2:0	RW	Reserved

7.1.6 Wake on LAN Address Byte 5 and 6 (Register A007_H)

This section describes the Wake on LAN Address Byte 5 and 6 registers in detail.

Wake on LAN Address Byte 5 and 6 (Register A007_H)

This register holds the WoL MAC address's bytes 4 and 5.

COM_EXT_MAC_ADDR_CFG1	Offset	Reset Value
Wake on LAN Address Byte 5 and 6 (Register A007 _H)	A007 _H	0000 _H

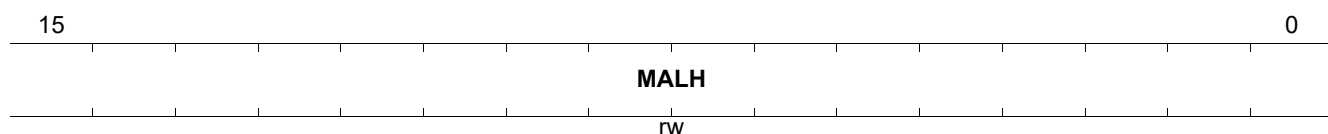

Field	Bits	Type	Description
MALH	15:0	RW	MAC Address Location 47-32 This MALH field holds the first two octets of the MAC address used for WOL. The default is 0 _B .

7.1.7 Wake on LAN Address Byte 3 and 2 (Register A008_H)

This section describes the Wake on LAN Address Byte 3 and 2 registers in detail.

Wake on LAN Address Byte 5 and 6 (Register A008_H)

This register holds the WoL MAC address's bytes 3 and 2.

COM_EXT_MAC_ADDR_CFG2	Offset	Reset Value
Wake on LAN Address Byte 3 and 2 (Register A008 _H)	A008 _H	0000 _H
15		0
MALM		
rw		

Field	Bits	Type	Description
MALM	15:0	RW	<p>MAC Address Location 31-16</p> <p>This MALM field holds the middle two octets of the MAC address used for WOL.</p> <p>The default is 0_B.</p>

7.1.8 Wake on LAN Address Byte 1 and 0 (Register A009_H)

This section describes the Wake on LAN Address Byte 1 and 0 registers in detail.

Wake on LAN Address Byte 1 and 0 (Register A009_H)

This register holds the WoL MAC address's bytes 1 and 0.

COM_EXT_MAC_ADDR_CFG3	Offset	Reset Value
Wake on LAN Address Byte 1 and 0 (Register A009 _H)	A009 _H	0000 _H
15		0
MALL		
rw		

Field	Bits	Type	Description
MALL	15:0	RW	MAC Address Location 15-0 This MALL field holds the last two octets of the MAC address used for WOL. The default is 0 _B .

7.1.9 Wake on LAN Control Register (Register A00A_H)

This section describes the Wake on LAN Control Register in detail.

Wake on LAN Address Byte 1 and 0 (Register A00A_H)

This register configures the WoL function.

COM_EXT_WOL_CFG	Offset	Reset Value
Wake on LAN Control Register (Register A00AH)	A00A _H	0002 _H

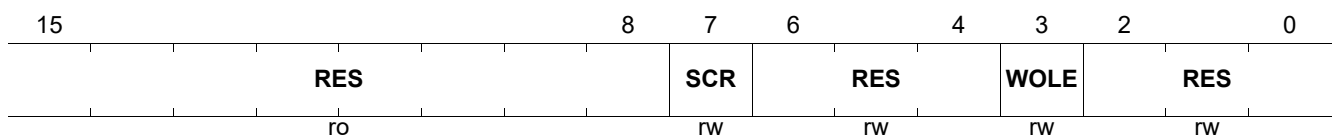

Field	Bits	Type	Description
RES	15:8	RO	Reserved Reserved The default is 0 _B .
SCR	7	RW	RGMIIE Enable This SCR field enables or disables the RGMIIE interface. 0 _B Enable the RGMIIE interface. (Default) 1 _B Disable the RGMIIE interface.
RES	6:4	RW	Reserved
WOLE	3	RW	WOL Enable This WOLE field controls the operation mode of the Wake-on-LAN feature. 0 _B WOL is disabled. (Default) 1 _B WOL is enabled.
RES	2:0	RW	Reserved

7.1.10 LED General Configuration Register (Register A00B_H)

This section describes the LED General Configuration Register in detail.

LED General Configuration Register (Register A00B_H)

This register controls the LED general configuration.

COM_EXT_LED_GEN_CFG	Offset	Reset Value
LED General Configuration Register (Register A00B_H)	A00B_H	E000_H

15	14	13	12	11	9	8	7	6	5	4	3	2	1	0
COLBS	JABLD	LPLD	DLDT	RES		L2FE	L2FM	L1FE	L1FM	L0FE	L0FM			
RW	RW	RW	RW	RO		RW	RW	RW	RW	RW	RW	RW		

Field	Bits	Type	Description
COLBS	15	RW	LED Collision Blink Frequency This COLBS field controls the collision LED blinking frequency. The blink function is only value if COM_EXT_LED0_CFG.LCBE0 , COM_EXT_LED1_CFG.LCBE0 , or COM_EXT_LED0_CFG.LCBE0 is set to 1 _B . 0 _B When a collision occurs, blink with the frequency defined in COM_EXT_LED_BLINK_CFG.LFEQ1 . 1 _B When a collision occurs, blink with the frequency defined in COM_EXT_LED_BLINK_CFG.LFEQ2 . (Default)
JABLD	14	RW	LED Jabber Blink This JABLD field controls LED blinking on a jabber condition. 0 _B Blinking under jabber conditions. 1 _B No blinking under jabber conditions. (Default)
LPLD	13	RW	LED Loopback Display This LPLD field controls whether the LED should indicate an internal loopback condition. 0 _B Blinking under loopback conditions. 1 _B No blinking under loopback conditions. (Default)
DLDT	12	RW	Auto-Negotiation Display This DLDT field controls whether the LED should indicate the auto-negotiation state. 0 _B Blinking when auto-negotiation is at LINK_GOOD_CHECK condition. It means the link is not yet ready. (Default) 1 _B No blinking to indicate auto-negotiation state.
RES	11:9	RO	Reserved Reserved The default is 0 _B .

Field	Bits	Type	Description (cont'd)
L2FE	8	RW	<p>LED2 Force Enable</p> <p>This L2FE field controls the enable of LED2 force mode defined in the L2FM field.</p> <p>0_B Disable LED2 force mode. (Default)</p> <p>1_B Enable LED2 force mode.</p>
L2FM	7:6	RW	<p>LED2 Force Mode</p> <p>This L2FM field controls the LED2 blink pattern in force mode. Force mode is enabled with the L2FE bit.</p> <p>00_B Force the LED off. (Default)</p> <p>01_B Force the LED on.</p> <p>10_B Force the LED to blink with the frequency defined in COM_EXT_LED_BLINK_CFG.LFEQ1.</p> <p>11_B Force the LED to blink with the frequency defined in COM_EXT_LED_BLINK_CFG.LFEQ2.</p>
L1FE	5	RW	<p>LED1 Force Enable</p> <p>This L1FE field controls the enable of LED1 force mode defined in the L1FM field.</p> <p>0_B Disable LED1 force mode. (Default)</p> <p>1_B Enable LED1 force mode.</p>
L1FM	4:3	RW	<p>LED1 Force Mode</p> <p>This L1FM field controls the LED1 blink pattern in force mode. Force mode is enabled with the L1FE bit.</p> <p>00_B Force the LED off. (Default)</p> <p>01_B Force the LED on.</p> <p>10_B Force the LED to blink with the frequency defined in COM_EXT_LED_BLINK_CFG.LFEQ1.</p> <p>11_B Force the LED to blink with the frequency defined in COM_EXT_LED_BLINK_CFG.LFEQ2.</p>
L0FE	2	RW	<p>LED0 Force Enable</p> <p>This L0FE field controls the enable of LED0 force mode defined in the L0FM field.</p> <p>0_B Disable LED0 force mode. (Default)</p> <p>1_B Enable LED0 force mode.</p>
L0FM	1:0	RW	<p>LED0 Force Mode</p> <p>This L0FM field controls the LED0 blink pattern in force mode. Force mode is enabled with the L0FE bit.</p> <p>00_B Force the LED off. (Default)</p> <p>01_B Force the LED on.</p> <p>10_B Force the LED to blink with the frequency defined in COM_EXT_LED_BLINK_CFG.LFEQ1.</p> <p>11_B Force the LED to blink with the frequency defined in COM_EXT_LED_BLINK_CFG.LFEQ2.</p>

7.1.11 LED0 Configuration Register (Register A00C_H)

This section describes the LED0 Configuration Register in detail.

LED0 Configuration Register (Register A00C_H)

This register configures LED0.

COM_EXT_LED0_CFG	Offset	Reset Value
LED0 Configuration Register (Register A00CH)	A00C _H	0610 _H

15	14	13	12	11	10	9	8	7	6	5	4	3	2	1	0
RES	LAB0	LFDE0	LHDE0	LTABE0	LRABE0	LTAE0	LRAE0	LGE0	LFE0	LBE0	LCBE0	LGBE0	LFBE0	LBBE0	
RW	RW	RW	RW	RW	RW	RW	RW	RW	RW	RW	RW	RW	RW	RW	RW

Field	Bits	Type	Description
RES	15:14	RW	Reserved
LAB0	13	RW	LED0 Activity Blink Indicator This field configures LED blinking when there is traffic activity no matter LED under constant on or off state. 0 _B LED0 only blinks at Link LED0 under ON state. (Default) 1 _B LED0 blinks no matter LED0 is under ON or OFF state.
LFDE0	12	RW	LED0 Full-Duplex Status This field control LED to show full-duplex status. 0 _B No full-duplex status support. (Default) 1 _B When the PHY link is up and the duplex mode is full-duplex, LED0 is ON. If the LED also has blink setting, the Blink setting has a higher priority.
LHDE0	11	RW	LED0 Half-Duplex Status This LHDE0 field controls how LED0 indicates half-duplex status. 0 _B Half-duplex mode is not indicated. (Default) 1 _B When the PHY link is up and the duplex mode is half-duplex, LED0 is ON. If the LED also has blink setting, the Blink setting has a higher priority.
LTABE0	10	RW	LED0 Tx Activity Blink This LTABE0 field controls how LED0 indicates Tx activity status. 0 _B Tx activity is not indicated. 1 _B When the PHY link is up and Tx activity occurs, LED0 blinks at the frequency defined in field COM_EXT_LED_BLINK_CFG.LFEQ2 in the COM_EXT_LED_BLINK_CFG register. (Default)
LRABE0	9	RW	LED0 Rx Activity Blink This LRABE0 field controls how LED0 indicates Rx activity status. 0 _B Rx activity is not indicated. 1 _B When the PHY link is up and Rx activity occurs LED0 blinks at the frequency defined in field COM_EXT_LED_BLINK_CFG.LFEQ2 in the COM_EXT_LED_BLINK_CFG register. (Default)

Field	Bits	Type	Description (cont'd)
LTAE0	8	RW	<p>LED0 Tx Activity Minimum On Time</p> <p>This LTAE0 field controls a minimum ON time for LED0 when Tx is active.</p> <p>0_B No minimum ON time for LED0 when Tx is active. (Default)</p> <p>1_B When the PHY link is up and Tx is active, LED0 is ON for at least 10 ms. If the LED also has a blink setting for Tx activity the blink setting has a higher priority.</p>
LRAE0	7	RW	<p>LED0 Rx Activity Minimum On Time</p> <p>This LRAE0 field controls a minimum ON time for LED0 when Rx is active.</p> <p>0_B No minimum ON time for LED0 when Rx is active. (Default)</p> <p>1_B When the PHY link is up and Rx is active, LED0 is ON for at least 10 ms. If the LED also has a blink setting for Rx activity the blink setting has a higher priority.</p>
LGE0	6	RW	<p>LED0 1000Base-T Ethernet Link Behavior</p> <p>This LGE0 field controls how LED0 indicates 1000 Mbps link speed.</p> <p>0_B No change to LED0 behavior. (Default)</p> <p>1_B When the PHY link up is and the speed mode is 1000 Mbps, LED0 is ON. If the LED also has a blink setting the blink setting has a higher priority.</p>
LFE0	5	RW	<p>LED0 100Base-T Ethernet Link Behavior</p> <p>This LFE0 field controls how LED0 indicates 100 Mbps link speed.</p> <p>0_B No change to LED0 behavior. (Default)</p> <p>1_B When the PHY link is up and the speed mode is 100 Mbps, LED0 is ON. If the LED also has blink setting the blink setting has a higher priority.</p>
LBE0	4	RW	<p>LED0 10Base-T Ethernet Link Behavior</p> <p>This LBE0 field controls how LED0 indicates 10 Mbps link speed.</p> <p>0_B No change to LED0 behavior.</p> <p>1_B When the PHY link up and the speed mode is 10 Mbps, LED0 is ON. If the LED also has blink setting the blink setting has a higher priority. (Default)</p>
LCBE0	3	RW	<p>LED0 Collision Behavior</p> <p>This LCBE0 field controls how LED0 indicates collisions.</p> <p>0_B No change to LED0 behavior. (Default)</p> <p>1_B When the PHY link is up and a collision occurs, blink LED0.</p>
LGBE0	2	RW	<p>LED0 1000Base-T Ethernet Link Blink</p> <p>This LGBE0 field controls how LED0 indicates 1000 Mbps link speed.</p> <p>0_B No change to LED0 behavior. (Default)</p> <p>1_B When the PHY link is up and the speed mode is 1000 Mbps, blink LED0.</p>
LFBE0	1	RW	<p>LED0 100Base-T Ethernet Link Blink</p> <p>This LFBE0 field controls how LED0 indicates 100 Mbps link speed.</p> <p>0_B No change to LED0 behavior. (Default)</p> <p>1_B When the PHY link is up and the speed mode is 100 Mbps, blink LED0.</p>

Field	Bits	Type	Description (cont'd)
LBBE0	0	RW	<p>LED0 10Base-T Ethernet Link Blink</p> <p>This LBBE0 field controls how LED0 indicates 10 Mbps link speed.</p> <p>0_B No change to LED0 behavior. (Default)</p> <p>1_B When the PHY link up and the speed mode is 10 Mbps, LED0 blink.</p>

7.1.12 LED1 Configuration Register (Register A00D_H)

This section describes the LED1 Configuration Register in detail.

LED1 Configuration Register (Register A00D_H)

This register configures LED1.

COM_EXT_LED1_CFG	Offset	Reset Value
LED1 Configuration Register (Register A00DH)	A00D _H	0620 _H

15	14	13	12	11	10	9	8	7	6	5	4	3	2	1	0
RES	LAB1	LFDE1	LHDE1	LTABE1	LRABE1	LTAE1	LRAE1	LGE1	LFE1	LBE1	LCBE1	LGBE1	LFBE1	LBBE1	
RW	RW	RW	RW	RW	RW	RW	RW	RW	RW	RW	RW	RW	RW	RW	RW

Field	Bits	Type	Description
RES	15:14	RW	Reserved
LAB1	13	RW	LED1 Activity Blink Indicator Same as LED0. See the COM_EXT_LED0_CFG description. The default is 0 _B .
LFDE1	12	RW	LED1 Full-Duplex Status Same as LED0. See the COM_EXT_LED0_CFG description. The default is 0 _B .
LHDE1	11	RW	LED1 Half-Duplex Status Same as LED0. See the COM_EXT_LED0_CFG description. The default is 0 _B .
LTABE1	10	RW	LED1 Tx Activity Blink Same as LED0. See the COM_EXT_LED0_CFG description. The default is 1 _B .
LRABE1	9	RW	LED1 Rx Activity Blink Same as LED0. See the COM_EXT_LED0_CFG description. The default is 1 _B .
LTAE1	8	RW	LED0 Tx Activity Minimum On Time Same as LED0. See the COM_EXT_LED0_CFG description. The default is 0 _B .
LRAE1	7	RW	LED1 Rx Activity Minimum On Time Same as LED0. See the COM_EXT_LED0_CFG description. The default is 0 _B .
LGE1	6	RW	LED1 1000Base-T Ethernet Link Behavior Same as LED0. See the COM_EXT_LED0_CFG description. The default is 0 _B .
LFE1	5	RW	LED1 100Base-T Ethernet Link Behavior Same as LED0. See the COM_EXT_LED0_CFG description. The default is 1 _B .

Field	Bits	Type	Description (cont'd)
LBE1	4	RW	LED1 10Base-T Ethernet Link Behavior Same as LED0. See the COM_EXT_LED0_CFG description. The default is 0 _B .
LCBE1	3	RW	LED1 Collision Behavior Same as LED0. See the COM_EXT_LED0_CFG description. The default is 0 _B .
LGBE1	2	RW	LED1 1000Base-T Ethernet Link Blink Same as LED0. See the COM_EXT_LED0_CFG description. The default is 0 _B .
LFBE1	1	RW	LED1 100Base-T Ethernet Link Blink Same as LED0. See the COM_EXT_LED0_CFG description. The default is 0 _B .
LBBE1	0	RW	LED1 10Base-T Ethernet Link Blink Same as LED0. See the COM_EXT_LED0_CFG description. The default is 0 _B .

7.1.13 LED2 Configuration Register (Register A00E_H)

This section describes the LED2 Configuration Register in detail.

LED2 Configuration Register (Register A00E_H)

This register configures LED2.

COM_EXT_LED2_CFG	Offset	Reset Value
LED2 Configuration Register (Register A00EH)	A00E _H	0640 _H

15	14	13	12	11	10	9	8	7	6	5	4	3	2	1	0
RES	LAB2	LFDE2	LHDE2	LTABE2	LRABE2	LTAE2	LRAE2	LGE2	LFE2	LBE2	LCBE2	LGBE2	LFBE2	LBBE2	
RW	RW	RW	RW	RW	RW	RW	RW	RW	RW	RW	RW	RW	RW	RW	RW

Field	Bits	Type	Description
RES	15:14	RW	Reserved
LAB2	13	RW	LED2 Activity Blink Indicator Same as LED0. See the COM_EXT_LED0_CFG description. The default is 0 _B .
LFDE2	12	RW	LED2 Full-Duplex Status Same as LED0. See the COM_EXT_LED0_CFG description. The default is 0 _B .
LHDE2	11	RW	LED2 Half-Duplex Status Same as LED0. See the COM_EXT_LED0_CFG description. The default is 0 _B .
LTABE2	10	RW	LED2 Tx Activity Blink Same as LED0. See the COM_EXT_LED0_CFG description. The default is 1 _B .
LRABE2	9	RW	LED2 Rx Activity Blink Same as LED0. See the COM_EXT_LED0_CFG description. The default is 1 _B .
LTAE2	8	RW	LED2 Tx Activity Minimum On Time Same as LED0. See the COM_EXT_LED0_CFG description. The default is 0 _B .
LRAE2	7	RW	LED2 Rx Activity Minimum On Time Same as LED0. See the COM_EXT_LED0_CFG description. The default is 0 _B .
LGE2	6	RW	LED2 1000Base-T Ethernet Link Behavior Same as LED0. See the COM_EXT_LED0_CFG description. The default is 1 _B .
LFE2	5	RW	LED2 100Base-T Ethernet Link Behavior Same as LED0. See the COM_EXT_LED0_CFG description. The default is 0 _B .

Field	Bits	Type	Description (cont'd)
LBE2	4	RW	LED2 10Base-T Ethernet Link Behavior Same as LED0. See the COM_EXT_LED0_CFG description. The default is 0 _B .
LCBE2	3	RW	LED2 Collision Behavior Same as LED0. See the COM_EXT_LED0_CFG description. The default is 0 _B .
LGBE2	2	RW	LED2 1000Base-T Ethernet Link Blink Same as LED0. See the COM_EXT_LED0_CFG description. The default is 0 _B .
LFBE2	1	RW	LED2 100Base-T Ethernet Link Blink Same as LED0. See the COM_EXT_LED0_CFG description. The default is 0 _B .
LBBE2	0	RW	LED2 10Base-T Ethernet Link Blink Same as LED0. See the COM_EXT_LED0_CFG description. The default is 0 _B .

7.1.14 LED Blinking Configuration Register (Register A00F_H)

This section describes the LED Blinking Configuration Register in detail.

LED Blinking Configuration Register (Register A00F_H)

This register configures the LED blink frequency.

COM_EXT_LED_BLINK_CFG	Offset	Reset Value
LED Blinking Configuration Register (Register A00FH)	A00F _H	0006 _H

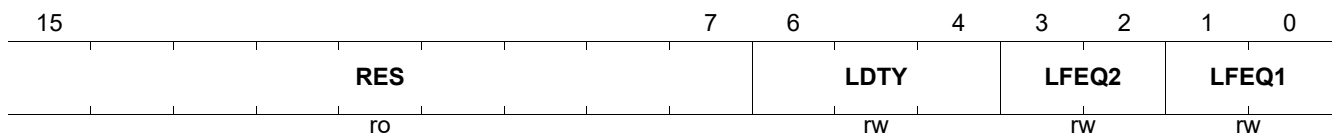

Field	Bits	Type	Description
RES	15:7	RO	Reserved Reserved The default is 0 _B .
LDTY	6:4	RW	LED Duty Cycle This LDTY field configures the blink duty cycle. 000 _B 50% on and 50% off. (Default) 001 _B 67% on and 33% off. 010 _B 75% on and 25% off. 011 _B 83% on and 17% off. 100 _B 50% on and 50% off. 101 _B 33% on and 67% off. 110 _B 25% on and 75% off. 111 _B 17% on and 83% off.
LFEQ2	3:2	RW	LED Blink Mode 2 Frequency This LFEQ2 field configures the blink frequency for blink mode 2. 00 _B 2 Hz 01 _B 4 Hz (Default) 10 _B 8 Hz 11 _B 16 Hz
LFEQ1	1:0	RW	LED Blink Mode 1 Frequency This LFEQ1 field configures the blink frequency for blink mode 1. 00 _B 2 Hz 01 _B 4 Hz 10 _B 8 Hz (Default) 11 _B 16 Hz

7.1.15 Pin Driving Strength Configuration Register (Register A010_H)

This section describes the Pin Driving Strength Configuration Register in detail.

LED Blinking Configuration Register (Register A010_H)

This register sets the pin interface's I/O drive strength.

COM_EXT_PAD_STR_CFG	Offset	Reset Value
Pin Driving Strength Configuration Register (Register A010H)	A010 _H	6BFF _H

15	13	12	11	10	9	8	7	6	5	4	3	2	1	0
RSDR		RSD2	IODE	IAHL	DSE		DM		RSD10		DII		DL	
rw		rw	rw	rw	rw		rw		rw		rw		rw	

Field	Bits	Type	Description
RSDR	15:13	RW	RGMIIRx Clock Pin Drive Strength Sets the drive strength of the RX_CLK pin. 000 _B Weakest 111 _B Strongest
RSD2	12	RW	Drive Strength of RGMII Data and Control This RGMII_SW_DR2 field holds bit 2 of the drive strength of the RXD/RX_CTL pin. See COM_EXT_PAD_STR_CFG.RGMII_SW_DR10 . 000 _B Weakest 111 _B Strongest
IODE	11	RW	Interrupt Output Open Drain Enable This IODE field controls the interrupt pin output mode. 0 _B This interrupt pin acts as a push-pull output. 1 _B This interrupt pin acts as open drain.
IAHL	10	RW	Interrupt Polarity Active High This IAHL field configures the interrupt line polarity sensitivity. 0 _B The interrupt line is low-active. 1 _B The interrupt line is high-active.
DSE	9:8	RW	SyncE Pin Drive Strength Sets the drive strength of the SyncE pin. 00 _B Weakest 11 _B Strongest (Default)
DM	7:6	RW	MDIO Pin Drive Strength Sets the drive strength of the MDIO pin. 00 _B Weakest 11 _B Strongest

Field	Bits	Type	Description (cont'd)
RSD10	5:4	RW	<p>Drive Strength of RGMII Data and Control</p> <p>This RGMII_SW_DR10 field sets the drive strength of the RXD/RX_CTL pin. This field holds bit 1 and bit 0. Bit 2 is held in COM_EXT_PAD_STR_CFG.RGMII_SW_DR2.</p> <p>000_B Weakest 111_B Strongest</p>
DII	3:2	RW	<p>Interrupt Pin Drive Strength</p> <p>Sets the drive strength of the interrupt pin.</p> <p>00_B Weakest 11_B Strongest</p>
DL	1:0	RW	<p>LED Pin Drive Strength</p> <p>Sets the drive strength of GPHY_LED0, GPHY_LED1, and GPHY_LED2.</p> <p>00_B Weakest 11_B Strongest</p>

7.1.16 Pin Driving Strength Configuration Register (Register A012_H)

This section describes the Pin Driving Strength Configuration Register in detail.

Pin Driving Strength Configuration Register (Register A012_H)

This register sets the pin interface's I/O drive strength.

COM_EXT_SYNC_CFG	Offset	Reset Value
SyncE Configuration Register (Register A012 _H)	A012 _H	00C8 _H

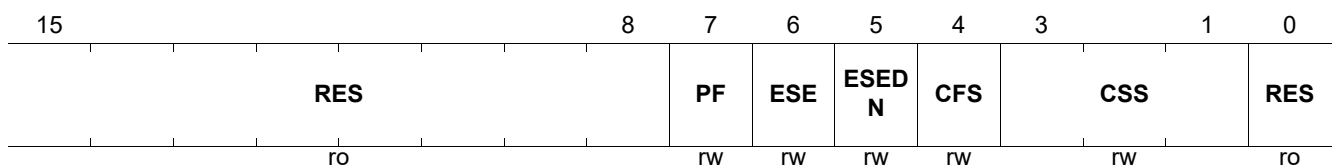

Field	Bits	Type	Description
RES	15:8	RO	Reserved
PF	7	RW	PHY to Fiber This PF field controls UTP activation. 0 _B Always enable UTP. 1 _B In UTP to FIBER mode, do not enable UTP until the fiber link is up. (Default)
ESE	6	RW	SyncE Output Control This ESE field controls the SyncE clock output. 0 _B Disable SyncE clock output. 1 _B Enable SyncE clock output. (Default)
ESEDN	5	RW	Enable SyncE Clock Output under No Link This ESEDN field controls SyncE clock output behavior in link down state. 0 _B No SyncE clock output when the link is down. (Default) 1 _B Force SyncE clock output when the link is down.
CFS	4	RW	SyncE Clock Frequency Select This CFS field selects the clock frequency. 0 _B 25 MHz. (Default) 1 _B 125 MHz.
CSS	3:1	RW	SyncE Clock Source Select This CSS field select the clock source for generating SyncE clock output. 000 _B Use the internal 125 MHz PLL as the output clock. 001 _B Use the TPI recovered clock. 010 _B Reserved 011 _B Use the RGMII Tx clock. 100 _B Use the reference 25 MHz clock. (Default) 101 _B Use 25 MHz with SSC.
RES	0	RO	Reserved

7.2 UTP Extended Register

This section describes the UTP extended register.

Table 22 Registers Overview - UTP Extended Register

Register Short Name	Register Long Name	Reset Value
UTP_EXT_10BT_DBG	10 M Base-Te Debug Mode Register (Register 000AH)	1000 _H
UTP_EXT_SLEEP_CTRL	Sleep Mode Control Register (Register 0027H)	E812 _H
UTP_EXT_PKG_RX_VALID_0	Packet Rx Valid High Register (Register 00A3H)	0000 _H
UTP_EXT_PKG_RX_VALID_1	Packet Rx Valid Low Register (Register 00A4H)	0000 _H
UTP_EXT_PKG_RX_OS_0	Packet Rx Oversize High Register (Register 00A5H)	0000 _H
UTP_EXT_PKG_RX_OS_1	Packet Rx Oversize Low Register (Register 00A6H)	0000 _H
UTP_EXT_PKG_RX_US_0	Packet Rx Undersize High Register (Register 00A7H)	0000 _H
UTP_EXT_PKG_RX_US_1	Packet Rx Undersize Low Register (Register 00A8H)	0000 _H
UTP_EXT_PKG_RX_ERR	Packet Rx CRC Register (Register 00A9H)	0000 _H
UTP_EXT_PKG_RX_OS_BAD	Packet Rx CRC Oversize Register (Register 00AAH)	0000 _H
UTP_EXT_PKG_RX_FRAGMENT	Packet Rx Fragment Register (Register 00ABH)	0000 _H
UTP_EXT_PKG_RX_NOSFD	Packet Rx No SFD Register (Register 00ACH)	0000 _H
UTP_EXT_PKG_TX_VALID_0	Packet Tx High Register (Register 00ADH)	0000 _H
UTP_EXT_PKG_TX_VALID_1	Packet Tx Low Register (Register 00AEH)	0000 _H
UTP_EXT_PKG_TX_OS_0	Packet Tx Oversize High Register (Register 00AFH)	0000 _H
UTP_EXT_PKG_TX_OS_1	Packet Tx Oversize Low Register (Register 00B0H)	0000 _H
UTP_EXT_PKG_TX_US_0	Packet Tx Undersize High Register (Register 00B1H)	0000 _H
UTP_EXT_PKG_TX_US_1	Packet Tx Undersize Low Register (Register 00B2H)	0000 _H
UTP_EXT_PKG_TX_ERR	Packet Tx CRC Register (Register 00B3H)	0000 _H
UTP_EXT_PKG_TX_OS_BAD	Packet Tx CRC Oversize Register (Register 00B4H)	0000 _H
UTP_EXT_PKG_TX_FRAGMENT	Packet Tx Fragment Register (Register 00B5H)	0000 _H
UTP_EXT_PKG_TX_NOSFD	Packet Tx No SFD Register (Register 00B6H)	0000 _H

7.2.1 10 M Base-Te Debug Mode Register (Register 000A_H)

This section describes the 10 M Base-Te Debug Mode Register in detail.

10 M Base-Te Debug Mode Register (Register 000A_H)

This register is used for 10 Base-T mode IEEE compliance and external loopback testing.

UTP_EXT_10BT_DBG	Offset	Reset Value
10 M Base-Te Debug Mode Register (Register 000A _H)	000A _H	1000 _H

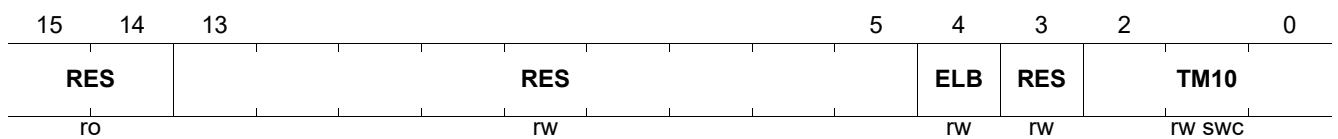

Field	Bits	Type	Description
RES	15:14	RO	Reserved Reserved The default is 0 _B .
RES	13:5	RW	Reserved
ELB	4	RW	External Loopback Control This field enables/disables the external loopback. 1 _B Enable the external loopback. 0 _B Disable the external loopback. (Default)
RES	3	RW	Reserved
TM10	2:0	RW SWC	10Base-T Ethernet Test Mode This field configures the 10Base-Te test modes. 000 _B Normal operation (Default) 101 _B Normal operation 110 _B Normal operation 111 _B Normal operation 001 _B Used for IEEE harmonic test with 10 MHz sine wave and packets with "all ones". 010 _B Enables a pseudo random packet for TP_IDLE/Jitter/Differential Voltage testing. 011 _B Enables a "normal" link pulse 110 _B Used to generate a 5 MHz sine wave

7.2.2 Sleep Mode Control Register (Register 0027_H)

This section describes the Sleep Mode Control Register in detail.

Sleep Mode Control Register (Register 0027_H)

This register configures the power saving mode.

UTP_EXT_SLEEP_CTRL	Offset	Reset Value
Sleep Mode Control Register (Register 0027 _H)	0027 _H	E812 _H

15	14	13	12	11	10	6	5	4	0
ESS	PLIS	SPS	RES			RES	SLP		RES
rw	rw	rw	rw			ro	ro		ro

Field	Bits	Type	Description
ESS	15	RW	Sleep Mode Control This field enables/disables the sleep mode feature of the PHY. In sleep mode, the PHY automatically disables AFE when the TPI has no link after a amount of certain time. 0 _B Disables the sleep mode feature. 1 _B Enables the sleep mode feature. (Default)
PLIS	14	RW	Sleep Mode PLL Control This field configures the PLL in the sleep mode of the PHY. 0 _B PLL stops in sleep mode. (Default) 1 _B PLL remains active in sleep mode.
SPS	13	RW	Sleep Mode Periodic Pulse Control This field configures the PHY sending periodic pulse signal in sleep mode. 0 _B Disables sending periodic pulses. 1 _B Enables sending periodic pulses. (Default)
RES	12:11	RW	Reserved
RES	10:6	RO	Reserved Reserved The default is 0 _B .
SLP	5	RO	Sleep Status This SLP field reports the status of the PHY. 0 _B PHY is enabled. (Default) 1 _B PHY is in sleep mode.
RES	4:0	RO	Reserved

7.2.3 Packet Rx Valid High Register (Register 00A3_H)

This section describes the Packet Rx Valid High Register in detail.

Packet Rx Valid High Register (Register 00A3_H)

This register is used for debugging Rx packets.

UTP_EXT_PKG_RX_VALID_0	Offset	Reset Value
Packet Rx Valid High Register (Register 00A3 _H)	00A3 _H	0000 _H
15		0
PIVH		
ro rc		

Field	Bits	Type	Description
PIVH	15:0	RO RC	<p>Rx Packet Valid Count High</p> <p>This PIVH field reports the number of Rx packets from line to PHY side with correct CRC and a packet length ≥ 64 bytes and ≤ 1518 bytes. These are the upper 16-bits of a 32-bit value. The lower 16-bits are in UTP_EXT_PKG_RX_OS_1.PIVL. The default is 0_B.</p>

7.2.4 Packet Rx Valid Low Register (Register 00A4_H)

This section describes the Packet Rx Valid Low Register in detail.

Packet Rx Valid Low Register (Register 00A4_H)

This register is used for debugging Rx packets.

UTP_EXT_PKG_RX_VALID_1 Packet Rx Valid Low Register (Register 00A4 _H)	Offset 00A4 _H	Reset Value 0000 _H
15		0
PIVL		
ro rc		

Field	Bits	Type	Description
PIVL	15:0	RO RC	<p>Rx Packet Valid Count Low</p> <p>This PIVL field reports the number of Rx packets from line to PHY side with correct CRC and a packet length ≥ 64 bytes and ≤ 1518 bytes. These are the lower 16-bits of a 32-bit value. The upper 16-bits are in UTP_EXT_PKG_RX_VALID_0.PIVH. The default is 0_B.</p>

7.2.5 Packet Rx Oversize High Register (Register 00A5_H)

This section describes the Packet Rx Oversize High Register in detail.

Packet Rx Valid Low Register (Register 00A5_H)

This register is used for debugging Rx packets.

UTP_EXT_PKG_RX_OS_0	Offset	Reset Value
Packet Rx Oversize High Register (Register 00A5 _H)	00A5 _H	0000 _H
15		0
PIOGH		
ro rc		

Field	Bits	Type	Description
PIOGH	15:0	RO RC	Oversize Rx Packet Count High This PIOGH field represents the number of Rx packets from line to PHY side with correct CRC and a packet length > 1518 bytes. These are the upper 16-bits of a 32-bit value. The lower 16-bits are in UTP_EXT_PKG_RX_OS_1.PIOGL . The default is 0 _B .

7.2.6 Packet Rx Oversize Low Register (Register 00A6_H)

This section describes the Packet Rx Oversize Low Register in detail.

Packet Rx Valid Low Register (Register 00A6_H)

This register is used for debugging Rx packets.

UTP_EXT_PKG_RX_OS_1	Offset	Reset Value
Packet Rx Oversize Low Register (Register 00A6 _H)	00A6 _H	0000 _H
15		0
PIOGL		
ro rc		

Field	Bits	Type	Description
PIOGL	15:0	RO RC	<p>Oversize Rx Packet Count Low</p> <p>This PIOGL field represents the number of Rx packets from line to PHY side with correct CRC and a packet length > 1518 bytes. These are the lower 16-bits of a 32-bit value. The upper 16-bits are in UTP_EXT_PKG_RX_OS_0.PIOGH. The default is 0_B.</p>

7.2.7 Packet Rx Undersize High Register (Register 00A7_H)

This section describes the Packet Rx Undersize High Register in detail.

Packet Rx Undersize High Register (Register 00A7_H)

This register is used for debugging Rx packets.

UTP_EXT_PKG_RX_US_0	Offset	Reset Value
Packet Rx Undersize High Register (Register 00A7 _H)	00A7 _H	0000 _H
15		0
PIUGH		
ro rc		

Field	Bits	Type	Description
PIUGH	15:0	RO RC	<p>Good Rx Packet Count High</p> <p>This PIUGH field represents the number of Rx packets from line to PHY side with correct CRC and a packet length < 64 bytes. These are the upper 16-bits of a 32-bit value. The lower 16-bits are in UTP_EXT_PKG_RX_US_1.PIUGL.</p> <p>The default is 0_B.</p>

7.2.8 Packet Rx Undersize Low Register (Register 00A8_H)

This section describes the Packet Rx Undersize Low Register in detail.

Packet Rx Undersize Low Register (Register 00A8_H)

This register is used for debugging Rx packets.

UTP_EXT_PKG_RX_US_1	Offset	Reset Value
Packet Rx Undersize Low Register (Register 00A8 _H)	00A8 _H	0000 _H
15		0
PIUGL		
ro rc		

Field	Bits	Type	Description
PIUGL	15:0	RO RC	Good Rx Packet Count Low This PIUGL field represents the number of Rx packets from line to PHY side with correct CRC and a packet length < 64 bytes. These are the lower 16-bits of a 32-bit value. The upper 16-bits are in UTP_EXT_PKG_RX_US_0.PIUGH . The default is 0 _B .

7.2.9 Packet Rx CRC Register (Register 00A9_H)

This section describes the Packet Rx CRC Register in detail.

Packet Rx CRC Register (Register 00A9_H)

This register is used for debugging Rx packets.

UTP_EXT_PKG_RX_ERR	Offset	Reset Value
Packet Rx CRC Register (Register 00A9 _H)	00A9 _H	0000 _H

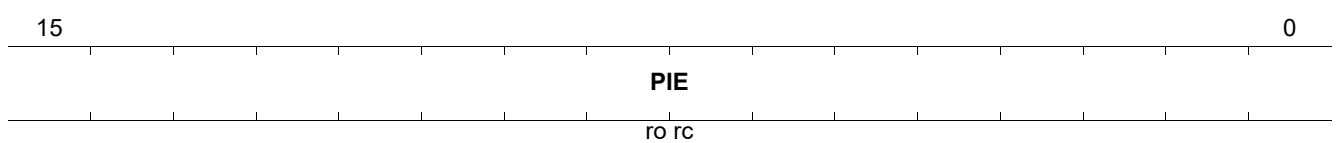

Field	Bits	Type	Description
PIE	15:0	RO RC	Rx Packet Error Count This PIE field represents the number of Rx packets from line to PHY side with corrupted CRC and a packet length ≥ 64 bytes and ≤ 1518 bytes. The default is 0 _B .

7.2.10 Packet Rx CRC Oversize Register (Register 00AA_H)

This section describes the Packet Rx CRC Oversize Register in detail.

Packet Rx CRC Oversize Register (Register 00AA_H)

This register is used for debugging Rx packets.

UTP_EXT_PKG_RX_OS_BAD	Offset	Reset Value
Packet Rx CRC Oversize Register (Register 00AA _H)	00AA _H	0000 _H
15		0
PIOB		
ro rc		

Field	Bits	Type	Description
PIOB	15:0	RO RC	Rx Oversize Packet CRC Error Count This field represents the number of Rx packets from line to PHY side with corrupted CRC and a packet length \geq 1518 bytes. The default is 0 _B .

7.2.11 Packet Rx Fragment Register (Register 00AB_H)

This section describes the Packet Rx Fragment Register in detail.

Packet Rx CRC Oversize Register (Register 00AB_H)

This register is used for debugging Rx packets.

UTP_EXT_PKG_RX_FRAGMENT	Offset	Reset Value
Packet Rx Fragment Register (Register 00AB _H)	00AB _H	0000 _H
15		0
	PIF	
	ro rc	

Field	Bits	Type	Description
PIF	15:0	RO RC	Rx Fragment Packet Error Count This field represents the number of Rx packets from line to PHY side with corrupted CRC and a packet length <=64 bytes. The default is 0 _B .

7.2.12 Packet Rx No SFD Register (Register 00AC_H)

This section describes the Packet Rx No SFD Register in detail.

Packet Rx CRC Oversize Register (Register 00AC_H)

This register is used for debugging Rx packets.

UTP_EXT_PKG_RX_NOSFD	Offset	Reset Value
Packet Rx No SFD Register (Register 00ACH)	00AC _H	0000 _H
	15	0
	PINF	
	ro rc	

Field	Bits	Type	Description
PINF	15:0	RO RC	<p>Rx Packet Missing Start Frame Delimiter Count</p> <p>This PINF field represents the number of Rx packets from line to PHY side, with missing Start Frame Delimiter (SFD). The default is 0_B.</p>

7.2.13 Packet Tx High Register (Register 00AD_H)

This section describes the Packet Tx High Register in detail.

Packet Rx CRC Oversize Register (Register 00AD_H)

This register is used for debugging Tx packets.

UTP_EXT_PKG_TX_VALID_0	Offset	Reset Value
Packet Tx High Register (Register 00AD _H)	00AD _H	0000 _H
15		0
POVH		
RO RC		

Field	Bits	Type	Description
POVH	15:0	RO RC	<p>Tx Packet Valid Count High</p> <p>This POVH field represents the number of Tx packets sending from PHY GMII interface with correct CRC and a packet length ≥ 64 bytes and ≤ 1518 bytes. These are the upper 16-bits of a 32-bit value. The lower 16-bits are in UTP_EXT_PKG_TX_VALID_1.POVL. The default is 0_B.</p>

7.2.14 Packet Tx Low Register (Register 00AE_H)

This section describes the Packet Tx Low Register in detail.

Packet Tx Low Register (Register 00AE_H)

This register is used for debugging Tx packets.

UTP_EXT_PKG_TX_VALID_1	Offset	Reset Value
Packet Tx Low Register (Register 00AE _H)	00AE _H	0000 _H
15		0
	POVL	
	ro rc	

Field	Bits	Type	Description
POVL	15:0	RO RC	<p>Tx Packet Valid Count Low</p> <p>This POVL field represents the number of Tx packets from PHY GMII interface with correct CRC and a packet length ≥ 64 bytes and ≤ 1518 bytes. These are the lower 16-bit of a 32-bit value. The higher 16-bit are in the field UTP_EXT_PKG_TX_VALID_0.POVH. The default is 0_B.</p>

7.2.15 Packet Tx Oversize High Register (Register 00AF_H)

This section describes the Packet Tx Oversize High Register in detail.

Packet Tx Oversize High Register (Register 00AF_H)

This register is used for debugging Tx packets.

UTP_EXT_PKG_TX_OS_0	Offset	Reset Value
Packet Tx Oversize High Register (Register 00AF _H)	00AF _H	0000 _H
15		0
POOGH		
ro rc		

Field	Bits	Type	Description
POOGH	15:0	RO RC	Oversize Tx Packet Count High This POOGH field represents the number of Tx packets from PHY GMII interface with correct CRC and a packet length > 1518 bytes. These are the upper 16-bits of a 32-bit value. The lower 16-bits are UTP_EXT_PKG_TX_OS_1.POUGL . The default is 0 _B .

7.2.16 Packet Tx Oversize Low Register (Register 00B0_H)

This section describes the Packet Tx Oversize Low Register in detail.

Packet Tx Oversize Low Register (Register 00B0_H)

This register is used for debugging Tx packets.

UTP_EXT_PKG_TX_OS_1	Offset	Reset Value
Packet Tx Oversize Low Register (Register 00B0 _H)	00B0 _H	0000 _H
15		0
POOGL		
ro rc		

Field	Bits	Type	Description
POOGL	15:0	RO RC	<p>Oversize Tx Packet Count Low</p> <p>This POOGL field represents the number of Tx packets from PHY GMII interface with correct CRC and a packet length > 1518 bytes. These are the lower 16-bits of a 32-bit value. The upper 16-bits are UTP_EXT_PKG_TX_OS_0.POUGH. The default is 0_B.</p>

7.2.17 Packet Tx Undersize High Register (Register 00B1_H)

This section describes the Packet Tx Undersize High Register in detail.

Packet Tx Oversize Low Register (Register 00B1_H)

This register is used for debugging Tx packets.

UTP_EXT_PKG_TX_US_0	Offset	Reset Value
Packet Tx Undersize High Register (Register 00B1 _H)	00B1 _H	0000 _H
15		0
POUGH		
ro rc		

Field	Bits	Type	Description
POUGH	15:0	RO RC	Good Tx Packet Count High This POUGH field represents the number of Tx packets from PHY GMII interface with correct CRC and a packet length < 64 bytes. These are the upper 16-bits of a 32-bit value. The lower 16-bits are in UTP_EXT_PKG_TX_US_1.POUGL . The default is 0 _B .

7.2.18 Packet Tx Undersize Low Register (Register 00B2_H)

This section describes the Packet Tx Undersize Low Register in detail.

Packet Tx Undersize Low Register (Register 00B2_H)

This register is used for debugging Tx packets.

UTP_EXT_PKG_TX_US_1	Offset	Reset Value
Packet Tx Undersize Low Register (Register 00B2 _H)	00B2 _H	0000 _H
15		0
POUGL		
ro rc		

Field	Bits	Type	Description
POUGL	15:0	RO RC	<p>Good Tx Packet Count Low</p> <p>This POUGL field represents the number of Tx packets from PHY GMII interface with correct CRC and a packet length > 1518 bytes. These are the lower 16-bits of a 32-bit value. The upper 16-bits are in UTP_EXT_PKG_TX_US_0.POUGH. The default is 0_B.</p>

7.2.19 Packet Tx CRC Register (Register 00B3_H)

This section describes the Packet Tx CRC Register in detail.

Packet Tx Undersize Low Register (Register 00B3_H)

This register is used for debugging Tx packets.

UTP_EXT_PKG_TX_ERR	Offset	Reset Value
Packet Tx CRC Register (Register 00B3 _H)	00B3 _H	0000 _H
	15	0
	POE	
	RO RC	

Field	Bits	Type	Description
POE	15:0	RO RC	Tx Packet Error Count This POE field represents the number of Tx packets from PHY GMII interface with wrong CRC and a packet length ≥ 64 bytes and ≤ 1518 bytes. The default is 0 _B .

7.2.20 Packet Tx CRC Oversize Register (Register 00B4_H)

This section describes the Packet Tx CRC Oversize Register in detail.

Packet Tx CRC Oversize Register (Register 00B4_H)

This register is used for debugging Tx packets.

UTP_EXT_PKG_TX_OS_BAD	Offset	Reset Value
Packet Tx CRC Oversize Register (Register 00B4 _H)	00B4 _H	0000 _H
15		0
	POOB	
	ro rc	

Field	Bits	Type	Description
POOB	15:0	RO RC	Tx Oversize Packet CRC Error Count This POOB field represents the number of Tx packets from PHY GMII interface with wrong CRC and a packet length > 1518 bytes. The default is 0 _B .

7.2.21 Packet Tx Fragment Register (Register 00B5_H)

This section describes the Packet Tx Fragment Register in detail.

Packet Tx Fragment Register (Register 00B5_H)

This register is used for debugging Tx packets.

UTP_EXT_PKG_TX_FRAGMENT	Offset	Reset Value
Packet Tx Fragment Register (Register 00B5 _H)	00B5 _H	0000 _H
15		0
	POF	
	ro rc	

Field	Bits	Type	Description
POF	15:0	RO RC	Tx Fragment Packet Error Count This POF field represents the number of Tx packets from PHY GMII interface with a packet length < 64 bytes. The default is 0 _B .

7.2.22 Packet Tx No SFD Register (Register 00B6_H)

This section describes the Packet Tx No SFD Register in detail.

Packet Tx No SFD Register (Register 00B6_H)

This register is used for debugging Tx packets.

UTP_EXT_PKG_TX_NOSFD	Offset	Reset Value
Packet Tx No SFD Register (Register 00B6 _H)	00B6 _H	0000 _H
	15	0
	PONF	
	ro rc	

Field	Bits	Type	Description
PONF	15:0	RO RC	Tx Packet Missing Start Frame Delimiter Count This PONF field represents the number of Tx packets from PHY GMII interface, with missing SFD. The default is 0 _B .

8 Electrical Characteristics

This chapter provides the electrical characteristics for the MxL86110.

8.1 Absolute Maximum Ratings

Table 23 provides the absolute maximum ratings.

Table 23 Absolute Maximum Ratings

Parameter	Symbol	Values			Unit	Note / Test Condition
		Min.	Typ.	Max.		
Storage Temperature Limits	T _{STG}	–	–	40	°C	Devices should be stored according to these criteria: - The temperature must be less than 40 °C. - The relative humidity must be less than 90%. Before removing the devices from the moisture barrier bag, ensure that there is no condensation in the air.
Soldering Temperature	T _{SOL}	–	–	260	°C	Solder the devices with lead-free (Pb) solder that complies with J-STD-020D
Moisture Level 3 Temperature Limits	T _{ML3}	–	–	260	°C	According to IPS J-STD 020
Absolute Junction Temperature	T _{JABS}	–	–	125	°C	–
VDD3V3/VDDDAV3	V _{max}	-0.3	–	3.7	V	–
VDDA1V1/VDD	V _{max}	-0.2	1.1	1.4	V	–
2.5 V RGMII	V _{max}	-0.3	2.5	2.8	V	–
1.8 V RGMII	V _{max}	-0.3	1.8	2.3	V	–
3.3 V DC Input	V _{max}	-0.3	3.1	3.7	V	–
VDD/VDDA1V1 DC Input	V _{max}	-0.3	1.1	1.4	V	–

Attention: Stresses above the maximum values listed in this table may cause permanent damage to the device. Exposure to absolute maximum rating conditions for extended periods may affect device reliability. Maximum ratings are absolute ratings; exceeding only one of these values may cause irreversible damage to the device.

8.2 Operating Range

Table 24 defines the maximum values of voltages and temperature that must be applied to guarantee proper operation of the Gigabit Ethernet PHY. The values are relative to a ground voltage source supply (VSS) of 0.0 V.

Table 24 Supply Voltage and Temperature

Parameter	Symbol	Values			Unit	Note / Test Condition
		Min.	Typ.	Max.		
VDD3V3/VDDDAV3	V_{max}	2.97	3.3	3.63	V	–
VDDA1V1/VDD	V_{max}	1.045	1.1	1.32	V	–
2.5 V RGMII	V_{max}	2.25	2.5	2.75	V	–
1.8 V RGMII	V_{max}	1.62	1.8	1.98	V	–
Maximum Operating Junction Temperature	T_{JMAX}	–	–	125	°C	–
3.3 V Minimum High Level Output Voltage	V_{OH}	2.4	–	3.63	V	–
3.3 V Maximum Low Level Output Voltage	V_{OL}	-0.3	–	0.4	V	–
2.5 V Minimum High Level Output Voltage	V_{OH}	2	–	2.8	V	–
2.5 V Maximum Low Level Output Voltage	V_{OL}	-0.3	–	0.4	V	–
1.8 V Minimum High Level Output Voltage	V_{OH}	1.62	–	2.1	V	–
1.8 V Maximum Low Level Output Voltage	V_{OL}	-0.3	–	0.4	V	–
3.3 V Minimum High Level Input Voltage	V_{IH}	2	–	–	V	–
3.3 V Maximum Low Level Input Voltage	V_{IL}	–	–	0.8	V	–
2.5 V Minimum High Level Input Voltage	V_{IH}	1.7	–	–	V	–
2.5 V Maximum Low Level Input Voltage	V_{IL}	–	–	0.7	V	–
1.8 V Minimum High Level Input Voltage	V_{IH}	1.2	–	–	V	–
1.8 V Maximum Low Level Input Voltage	V_{IL}	–	–	0.5	V	–

8.3 AC Characteristics

The following sections describe the AC characteristics of the external interfaces as well as the power up and power down sequence.

8.3.1 Power Up and Power Down Sequence

Figure 12 shows the power up and power down sequence.

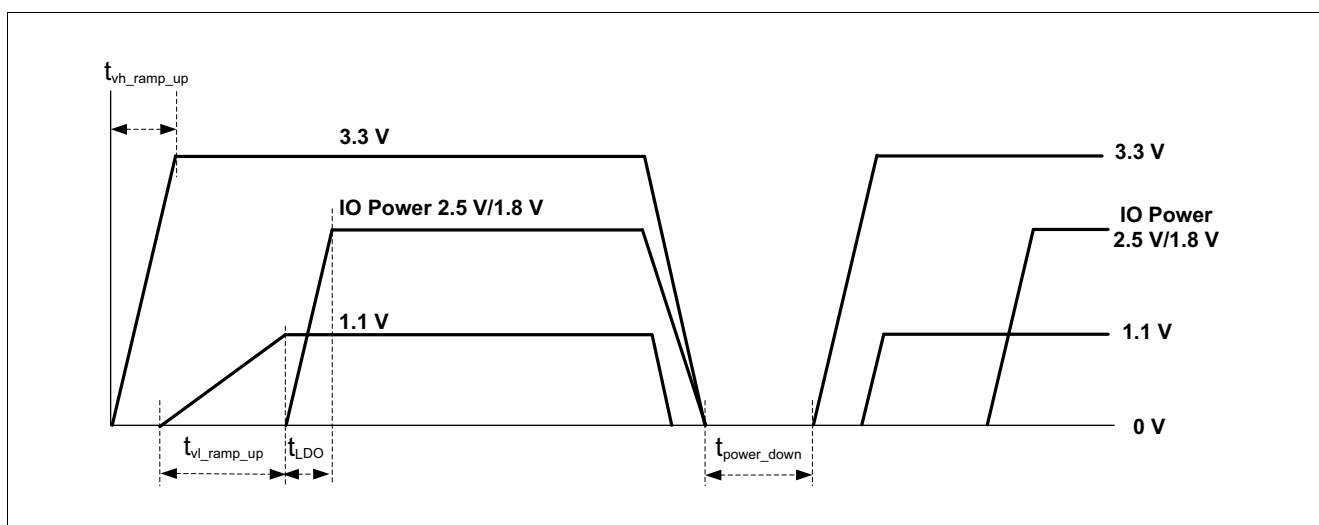

Figure 12 Power Up and Power Down Sequence

Note: When 1.1 V in external supply mode, the sequence for 3.3 V and 1.1 V can be powered up at the same time. The 1.1 V power supply must always be lower than 3.3 V power supply.

Table 25 Sequence Timing Parameters

Parameter	Symbol	Values			Unit	Note / Test Condition
		Min.	Typ.	Max.		
3.3 V Rising Time	Tvh_ramp_up	0.5	–	–	ms	–
3.3 V and 1.1 V Power-Down Duration	Tpower_down	100	–	–	ms	–
Core Power 1.1 V Ready Time	Tvi_ramp_up	–	–	2.5	ms	–
Internal LDO Ready Time	TLDO	–	–	100	us	–

8.3.2 Power Supply Rail Requirements

The maximum noise per power rail must be under these limits:

- 3.3 V: < 100 mV peak-to-peak
- VDD (1.1 V): < 80 mV peak-to-peak
- VDDA (1.1 V): < 50 mV peak-to-peak

8.3.3 Device Power Consumption

Table 26 and **Table 27** show the power consumption for the MxL86110.

Power consumption at 25 °C ambient temperature is indicated in **Table 26** for the different modes. The Link-up conditions are full-speed, bidirectional, and full-duplex. Power numbers are indicated for internal DCDC SVR.

Table 26 Device Power Consumption

Condition 25 °C 100 m Cable	VDDP (mA)	VDD3V3 (mA)	VDDA3V3 (mA)	Power Consumption (mW)
Link Down	1	7	21	95.7
Link Up at 1000 Mbps	13	51	61	412.5
Traffic at 1000 Mbps	28	57	61	481.8

Note: Test by typical corner chip with $VDDP/VDD3V3/VDDA3V3 = 3.3\text{ V}$ and $VDD/VDDA1V1 = 1.1\text{ V}$ under room temperature.

Table 27 Maximum Device Power Consumption

Condition 85 °C 100 m Cable	VDDP (mA)	VDD3V3 (mA)	VDDA3V3 (mA)	Power Consumption (mW)
Traffic at 1000 Mbps	30.8	62.7	67.1	530

Note: Test by fast corner chip with $VDDP/VDD3V3/VDDA3V3 = 3.3\text{ V}$ and $VDD/VDDA1V1 = 1.1\text{ V}$ at 85 °C.

8.3.4 MDIO Interface

Figure 13 shows a timing diagram of the slave MDIO interface for a clock cycle in the read, write, and turnaround modes. The timing measurements are annotated. The defined absolute values are summarized in **Table 28**.

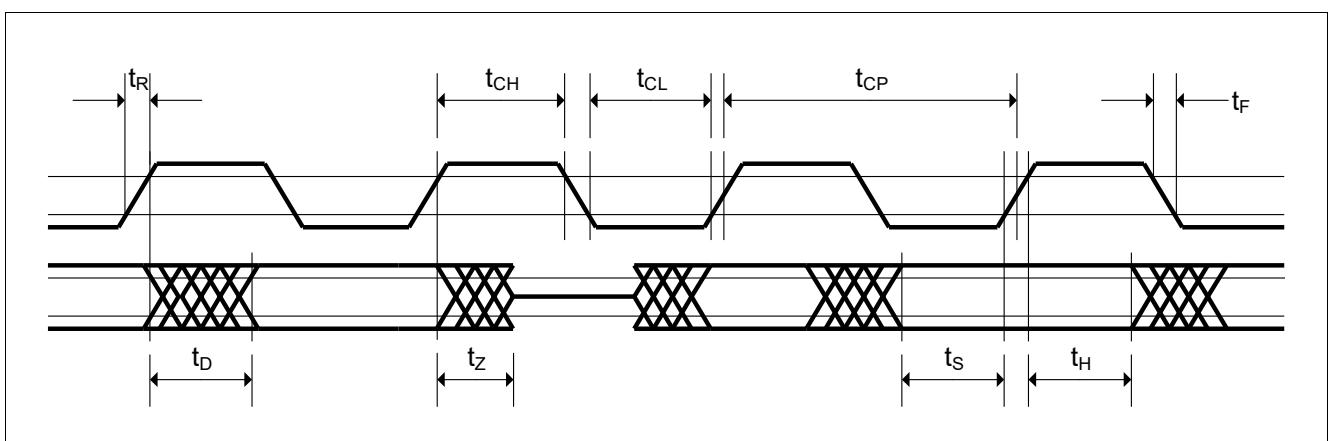

Figure 13 Timing Diagram for the MDIO Interface

Electrical Characteristics

Table 28 Timing Characteristics of the MDIO Interface

Parameter	Symbol	Values			Unit	Note / Test Condition
		Min.	Typ.	Max.		
MDC High Time	t_{CH}	32.0	–	–	ns	All provided timings were captured from a probe attached to the MDC pin of the device.
MDC Low Time	t_{CL}	32.0	–	–	ns	
MDC Clock Period	t_{CP}	80.0	–	–	ns	
MDC Clock Frequency ¹⁾	t_{CP}	–	2.5	12.5	MHz	
MDC Rise Time	t_R	–	–	10.0	ns	
MDC Fall Time	t_F	–	–	10.0	ns	
MDIO Input Setup Time	t_S	10.0	–	–	ns	Gigabit Ethernet PHY receive
MDIO Input Hold Time	t_H	10.0	–	–	ns	Gigabit Ethernet PHY receive
MDIO Output Delay Time	t_D	0.0	–	20	ns	Gigabit Ethernet PHY transmit
MDIO Output Setup Time	t_S	10.0	–	–	ns	MAC transmit
MDIO Output Hold Time	t_H	10.0	–	–	ns	MAC transmit

1) MDC clock supports range of frequencies up to 12.5 MHz. The typical (and default) frequency is 2.5 MHz.

8.3.5 RGMII Interface

This section describes the AC characteristics of the RGMII interface on the MxL86110. This interface conforms to the RGMII specification version 1.3 and version 2.0, as defined in [2] and [3] respectively. The RGMII interface operates at speeds of 10 Mbit/s, 100 Mbit/s, or 1000 Mbit/s.

8.3.5.1 Transmit Timing Characteristics

Figure 14 shows the timing diagram of the transmit RGMII interface on the MxL86110. Table 29 provides the RGMII timing requirements. Note the data and control signals are clocked in using the internal delayed version of the TX_CLK which is the external clock delayed by the integrated delay. The delay is adjustable in steps of 0.15 ns. This amount is configurable using the COM_EXT_RGMII_CFG1 register. See Section 7.1. An additional 2 ns of delay is available via pin strapping. See Section 3.16.

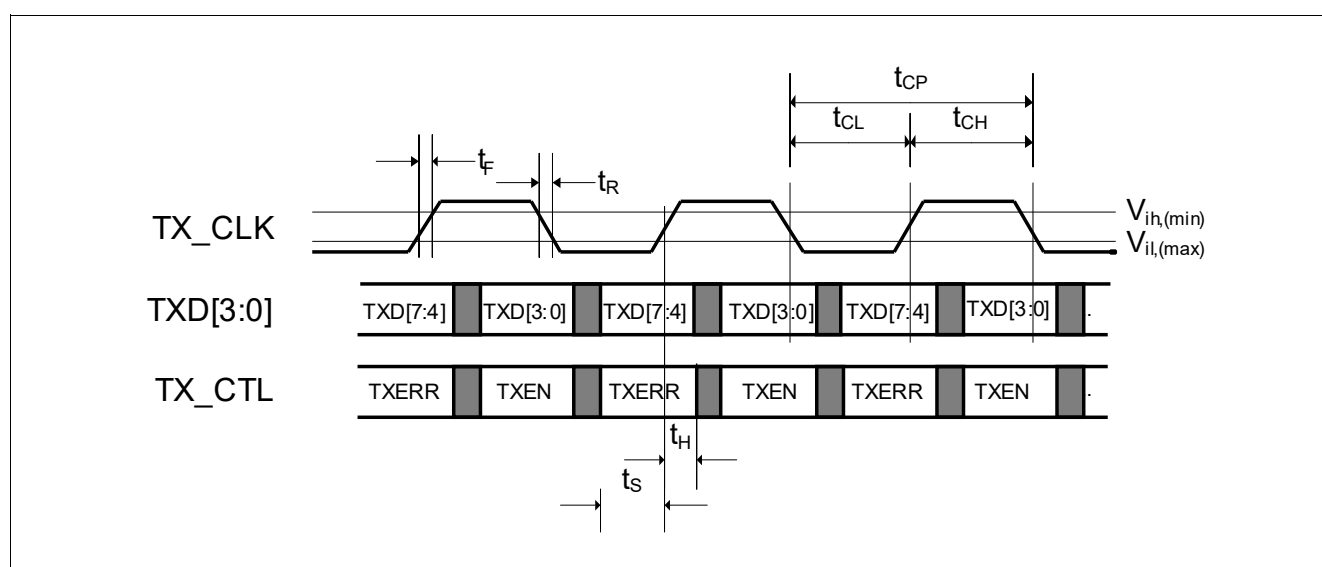

Figure 14 RGMII Transmit Timing Diagram

Table 29 RGMII Transmit Timing Characteristics

Parameter	Symbol	Values			Unit	Note / Test Condition
		Min.	Typ.	Max.		
Transmit Clock Frequency (TX_CLK)	f_{TX_CLK}	-50 ppm	125.0	+50 ppm	MHz	For 1000 Mbit/s speed
			25.0		MHz	For 100 Mbit/s speed
			2.5		MHz	For 10 Mbit/s speed
Transmit Clock Period (TX_CLK)	t_{CP}	7.2	8.0	8.8	ns	For 1000 Mbit/s speed
		36.0	40.0	44.0	ns	For 100 Mbit/s speed
		360.0	400.0	440.0	ns	For 10 Mbit/s speed
Duty Cycle	t_{CH}/t_{CP} , t_{CL}/t_{CP}	45.0	50.0	55.0	%	Speed-independent
Transmit Clock Rise Time (TX_CLK)	t_R	–	–	750.0	ps	20%→80%
Transmit Clock Fall Time (TX_CLK)	t_F	–	–	750.0	ps	80%→20%
Setup Time to $\uparrow\downarrow$ TX_CLK	t_S	1.0	–	–	ns	–

Table 29 RGMII Transmit Timing Characteristics

Parameter	Symbol	Values			Unit	Note / Test Condition
		Min.	Typ.	Max.		
Hold Time to $\uparrow\downarrow$ TX_CLK	t_H	1.0	–	–	ns	–
Integrated Transmit Clock Delay	t_{ID}	0.0	$k \cdot 0.15$	4.25	ns	Adjustable via COM_EXT_RGMII_CFG1 and the TXDLY pin strapping

8.3.5.2 Receive Timing Characteristics

Figure 15 shows the timing diagram of the receive RGMII interface on the MxL86110. It is referred to by Table 30, which specifies the timing requirements. The external clock on the pin is delayed by the integrated delay, which is adjustable in steps of 0.15 ns. This amount is configurable using the COM_EXT_RGMII_CFG1 register. See Section 7.1. An additional 2 ns of delay is available via pin strapping. See Section 3.16. If the integrated delay is not used it must be set to zero, in which case all the timings are related directly to the RX_CLK on the pin.

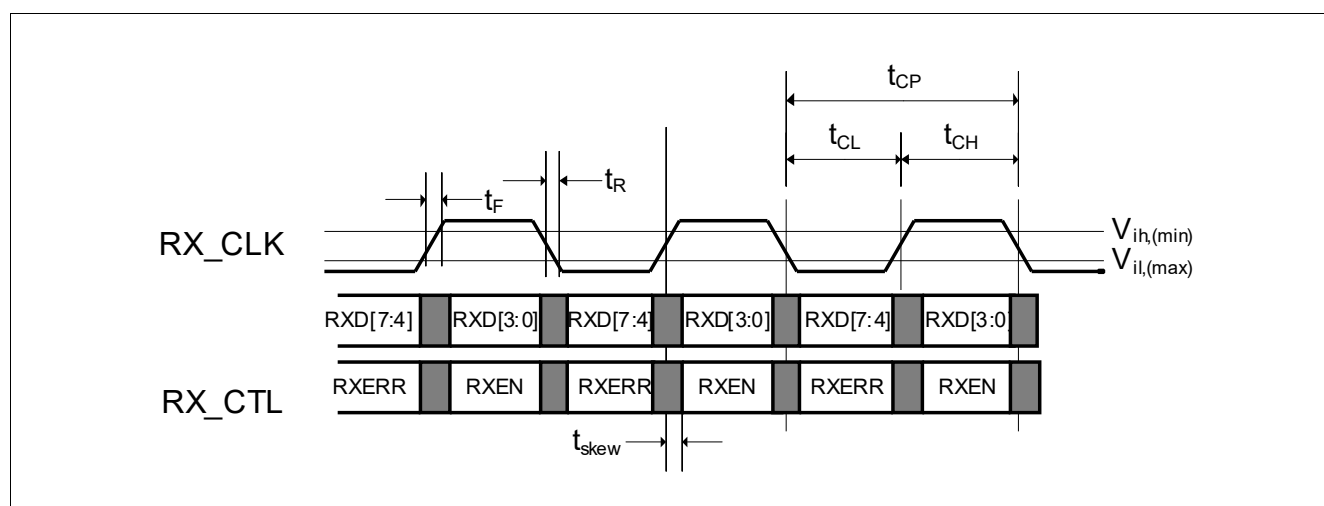

Figure 15 RGMII Receive Timing Diagram

Table 30 RGMII Receive Timing Characteristics

Parameter	Symbol	Values			Unit	Note / Test Condition
		Min.	Typ.	Max.		
Receive Clock Frequency (RX_CLK)	f_{RX_CLK}	-50 ppm	125.0	+50 ppm	MHz	For 1000 Mbit/s speed
			25.0		MHz	For 100 Mbit/s speed
			2.5		MHz	For 10 Mbit/s speed
Receive Clock Period (RX_CLK)	t_{CP}	7.2	8.0	8.8	ns	For 1000 Mbit/s speed
		36	40.0	46	ns	For 100 Mbit/s speed
		360	400.0	460	ns	For 10 Mbit/s speed
Duty Cycle	t_{CH}/t_{CP} , t_{CL}/t_{CP}	45.0	50.0	55.0	%	Speed-independent
Receive Clock Rise Time (TX_CLK)	t_R	–	–	750.0	ps	20% \rightarrow 80%
Receive Clock Fall Time (TX_CLK)	t_F	–	–	750.0	ps	80% \rightarrow 20%

Electrical Characteristics

Table 30 RGMII Receive Timing Characteristics

Parameter	Symbol	Values			Unit	Note / Test Condition
		Min.	Typ.	Max.		
Clock-to-Data Skew	t_{skew}	-0.5	0.0	0.5	ns	The skew between the RXC and RXC/RX_CTL should be less than 500 ps
Integrated Receive Clock Delay	t_{ID}	0.0	k*0.15	4.25	ns	Adjustable via COM_EXT_RGMII_CF G1 and the RXDLY pin strapping

8.3.6 Crystal Specification

The 25 MHz crystal must follow the specification given in [Table 31](#).

Table 31 Specification of the Crystal

Parameter	Symbol	Values			Unit	Note / Test Condition
		Min.	Typ.	Max.		
Frequency with 25 MHz Input	f_{clk25}	–	25.0	–	MHz	–
Total Frequency Stability ¹⁾	–	-50	–	+50	ppm	–
Series Resonant Resistance	–	–	–	50	Ω	–
Drive Level	–	–	–	0.5	mW	–
Crystal Output High Level	V_{ih}	1.4	–	–	V	–
Crystal Output Low Level	V_{il}	–	–	0.7	V	–

1) Total frequency stability refers to the sum all effects, not limited to general tolerance, aging, and temperature influences.

8.3.7 External Clock Requirements

Table 32 shows the external clock requirements.

Table 32 Specification of the External Clock

Parameter	Symbol	Values			Unit	Note / Test Condition
		Min.	Typ.	Max.		
Frequency with 25 MHz Input	f_{clk25}	–	25.0	–	MHz	–
Total Frequency Stability	–	-50	–	+50	ppm	–
Duty Cycle	–	40	–	60	%	–
Crystal Output High	V_{ih}	1.4	–	VDDA3V 3+0.3	V	–
Crystal Output Low	V_{il}	–	–	0.7	V	–
Rise Time (10% - 90%)	–	–	–	10	ns	–
Fall Time (10% - 90%)	–	–	–	10	ns	–

9 Package Outline

The MxL86110 device is available in a 40-pin QFN package with an exposed pin (EPAD). The pin pitch is 0.4 mm and the size of the EPAD is 3.7 x 3.7 mm. The EPAD is used as the common ground and must be connected to the PCB ground plane. The package is a lead-free “green package”, and its exact name for reference purposes is PG-QFN-40.

Table 33 provides the mechanical dimensions of the PG-QFN-40 package. **Figure 16** shows the top, side, and bottom dimension drawings of the package.

Table 33 PG-QFN-40 Mechanical Dimensions

Parameter	Symbol	Minimum	Nominal	Maximum
Total Thickness	A	0.80	0.85	0.95
Stand Off	A1	0	0.02	0.05
Mold Thickness	A2	-	0.65	-
L/F Thickness	A3	0.203 Ref		
Lead Width	b	0.15	0.20	0.25
Body Size	X	D 5.00 BSC		
	Y	E 5.00 BSC		
Lead Pitch	e	0.40 BSC		
EP Size	X	D2 3.60	3.70	3.80
	Y	E2 3.60	3.70	3.80
Lead Length	L	0.30	0.40	0.50

9.1 Thermal Resistance

Table 2 shows the package thermal resistance values.

Table 34 Thermal Resistance

Symbol	Parameter	Condition	Typ	Units
θ_{JA}	Thermal resistance - junction to ambient $\theta_{JA} = (T_J - T_A) / P$ P = Total power dissipation	JEDEC 3 in. x 4.5 in. 4-layer PCB with no air flow TA=25 °C	33.4	°C/W
		JEDEC 3 in. x 4.5 in. 4-layer PCB with no air flow TA=85 °C	31	°C/W
θ_{JB}	Thermal resistance - junction to board $\theta_{JB} = (T_J - T_B) / P_{bottom}$ P _{bottom} = Power dissipation from the bottom of the package to the PCB surface	JEDEC with no air flow	12.3	°C/W
θ_{JC-Top}	Thermal resistance - junction to case $\theta_{JC} = (T_J - T_C) / P_{top}$ P _{top} = Power dissipation from the top of the package	JEDEC with no air flow	28.4	°C/W

9.2 Chip Identification and Ordering Information

Figure 17 shows an example of the marking pattern on the MxL86110 device.

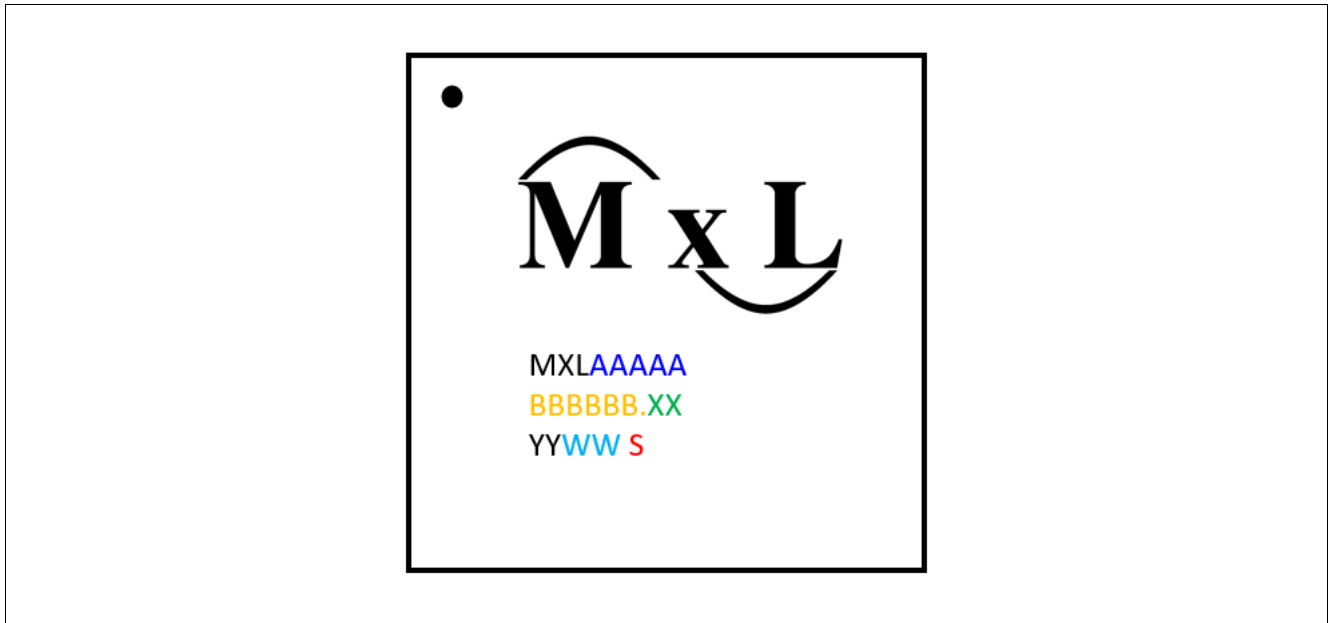

Figure 17 Chip Marking

Table 35 explains the chip marking information.

Table 35 Chip Marking Pattern

Marking	Description
MxL	MaxLinear Logo
AAAAA	MaxLinear Part Number
BBBBBB	Wafer Lot Number
XX	First wafer number in assembly lot, such as 01
YY	Year
WW	Work Week
S	Supplier Manufacturing Code

Table 36 provides the chip ordering information.

Table 36 Chip Ordering Information

Product Number	Ordering Code	Temperature Range	Package (X x Y mm)	MAC Interface	Description
MxL86110C	MxL86110C-AQB-R	0 °C to 70 °C	QFN40 (5 x 5)	RGMII	Ethernet Gigabit PHY with RGMII
MxL86110I	MxL86110I-AQB-R	-40 °C to 85 °C	QFN40 (5 x 5)	RGMII	

Table 37 provides the chip specific information.

Table 37 Chip Specific Information

RGMII Interface	MxL86110
OUI	F04CD5
Device ID	0018 _H
Revision	0000 _H
Register 2 PHY ID1	C133 _H
Register 3 PHY ID2	5580 _H

Standards References

- [1] IEEE 802.3-2018: "IEEE Standard for Ethernet", IEEE Computer Society
- [2] Hewlett Packard, "Reduced Gigabit Media Independent Interface (RGMII)", Version 1.3, 12.10.2000
- [3] Hewlett Packard, "Reduced Gigabit Media Independent Interface (RGMII)", Version 2.0, 04.01.2002

Terminology

A

ADS	Auto-Downspeed
ANEG	Auto-Negotiation

B

BER	Bit Error Rate
-----	----------------

C

CAT5	Category 5 Cabling
CDR	Clock and Data Recovery
CRS	Carrier Sense

D

DEC	Digital Echo Canceler
-----	-----------------------

E

EEE	Energy-Efficient Ethernet
EMI	Electromagnetic Interference

G

GbE	Gigabit Ethernet
GMII	Gigabit Media-Independent Interface

H

HCD	Highest Common Denominator
-----	----------------------------

I

IEEE	Institute of Electrical and Electronics Engineers
------	---

L

LAN	Local Area Network
LED	Light Emitting Diode
LPI	Low Power Idle
LSB	Least Significant Bit

M

MAC	Media Access Controller
MDI	Media-Dependent Interface
MDIO	Management Data Input/Output
MDIX	Media-Dependent Interface Crossover
MII	Media-Independent Interface
MMD	MDIO Manageable Device
MSB	Most Significant Bit

N

NC	Not Connected
----	---------------

O

OSI	Open Systems Interconnection
-----	------------------------------

OUI	Organizationally Unique Identifier
P	
PCB	Printed Circuit Board
PCS	Physical Coding Sublayer
PHY	Physical Layer (device)
Q	
QFN	Quad Flat Non-leaded
R	
Rx	Receive
S	
SDF	Start Frame Delimiter
SFP	Small Form-Factor Pluggable
SGMII	Serial Gigabit Media-Independent Interface
SoC	System on Chip
SQE	Signal Quality Errors
STA	Station Management Entity (MAC SoC), defined in IEEE 802.3
SVR	Selecting Voltage Regulator
T	
TPI	Twisted Pair Interface
Tx	Transmit
V	
VSS	Voltage Source Supply
W	
Wi-Fi	Wireless Local Area Network
WoL	Wake-on-LAN
X	
XNP	Extended Next Page

X-ON Electronics

Largest Supplier of Electrical and Electronic Components

Click to view similar products for [Ethernet Development Tools](#) category:

Click to view products by [MaxLinear](#) manufacturer:

Other Similar products are found below :

[KSZ8081RNB-EVAL](#) [EV06P90A](#) [GSW145-EVK-1](#) [GPY215-EVK-1](#) [EVB9512](#) [KSZ8041NL-EVAL](#) [KSZ8851SNL-EVAL](#) [KSZ8999-EVAL](#)
[WIZ550S2E-232-EVB](#) [EVB-MEC1428MECC](#) [MIKROE-2796](#) [3201](#) [KIT-14547](#) [OM14500/TJA1102JP](#) [DFR0125](#) [UKIT-006GP](#) [UKIT-](#)
[003FE](#) [UKIT-002GB](#) [UKIT-001FE](#) [EVB-KSZ9477](#) [OM-E-ETH](#) [3785](#) [A000024](#) [ASX00006](#) [ASX00021](#) [ASX00026](#) [PE-405](#) [G650-07975-01](#)
[76002138](#) [XKRR-Z8S-WZM](#) [EK-1700-21N3](#) [EK-1700-22M3](#) [EK-5700-2L](#) [ESP32-ETHERNET-KIT-VE](#) [EVB-KSZ9897-1](#) [SGMII-PEX-](#)
[RISER](#) [KITA2GTC377SECGTWT0BO1](#) [MICRO125-KIT](#) [U138](#) [MXL86110I-EVK-1](#) [KSZ9031RNX-EVAL](#) [AC164121](#) [AC164123](#)
[AC164132](#) [AC320004-5](#) [AC320004-6](#) [AC320004-7](#) [DM320114](#) [DM990004](#) [EV02N47A](#)