

GENERAL DESCRIPTION

The **SP337E** is a dual mode serial transceiver containing both RS-232 and RS-485/422 line drivers and receivers. The RS-232 mode provides three drivers and five receivers to support all eight signals commonly used in the DB9 serial port connector (3TX/5RX). In RS-485 mode the device features two independent high speed RS-485/422 transmit and receive channels (2TX/2RX). The default RS-485 configuration is full-duplex, but half-duplex operation can be obtained by tying together the TX and RI pins, and the TXEN and RXEN signals.

The **SP337E** is pin compatible to MaxLinear's SP334.

The **SP337EB** features a maximum data rate of 250kbps in RS-232 mode and a maximum data rate of 15Mbps in RS-485. However, the **SP337EU** features a maximum data rate of 1Mbps in RS-232 mode and a maximum data rate of 15Mbps in RS-485 mode.

The **MaxLinear**-patented high efficiency charge pumps (5,306,954) deliver true RS-232 driver output voltages from a single power supply from 3.3V to 5V. Charge pump outputs are self-monitored to minimize power consumption. The **SP337E** requires only four 0.1 μ F capacitors for complete functionality.

All RS-485 receivers or transceivers feature high impedance inputs which allow up to 256 transceivers on a single shared bus. When configured in RS-485 mode, each driver may be individually enabled or put into tri-state, simplifying use on shared buses or for bidirectional communication. The RS-485/422 drivers can be disabled (high-Z output) by the TXEN enable pin. The RS-232 receiver outputs can be disabled by the RXEN enable pin.

All receivers have advanced failsafe protection to prevent oscillation when inputs are un-connected. In RS-232 mode, each receiver input has a 5k Ω pull-down to ground. in RS-485 mode, receivers will default to output logic 1 if inputs are floating, shorted, or open but terminated.

All driver outputs and receiver inputs are protected against ESD strikes up to $\pm 15,000$ volts.

FEATURES

- 3.3V to 5V Single Supply Operation
- Robust ± 15 kV ESD Protection
 - Human Body Model
- Max Data Rate of 15Mbps in RS-485 mode and up to 1Mbps in RS-232 mode (SP337EU)
- 3 Drivers, 5 Receivers RS-232/V.28
- 2 Drivers, 2 Receivers RS-485/RS-422
 - Full-Duplex Configuration
 - 1/8th Unit Load, up to 256 receivers on bus
- RS-485 Advanced Failsafe on Open, Short or Terminated Lines
- Full Differential Driver Tri-State (Hi-Z) Control
- Receiver Output Tri-State Control
- TSSOP-28 Package

TYPICAL APPLICATIONS

- Dual Protocol Serial Ports (RS-232 or RS-485)
- Industrial Computers
- Industrial and Process Control Equipment
- Point-Of-Sales Equipment
- Networking Equipment
- HVAC Controls Equipment
- Building Security Equipment

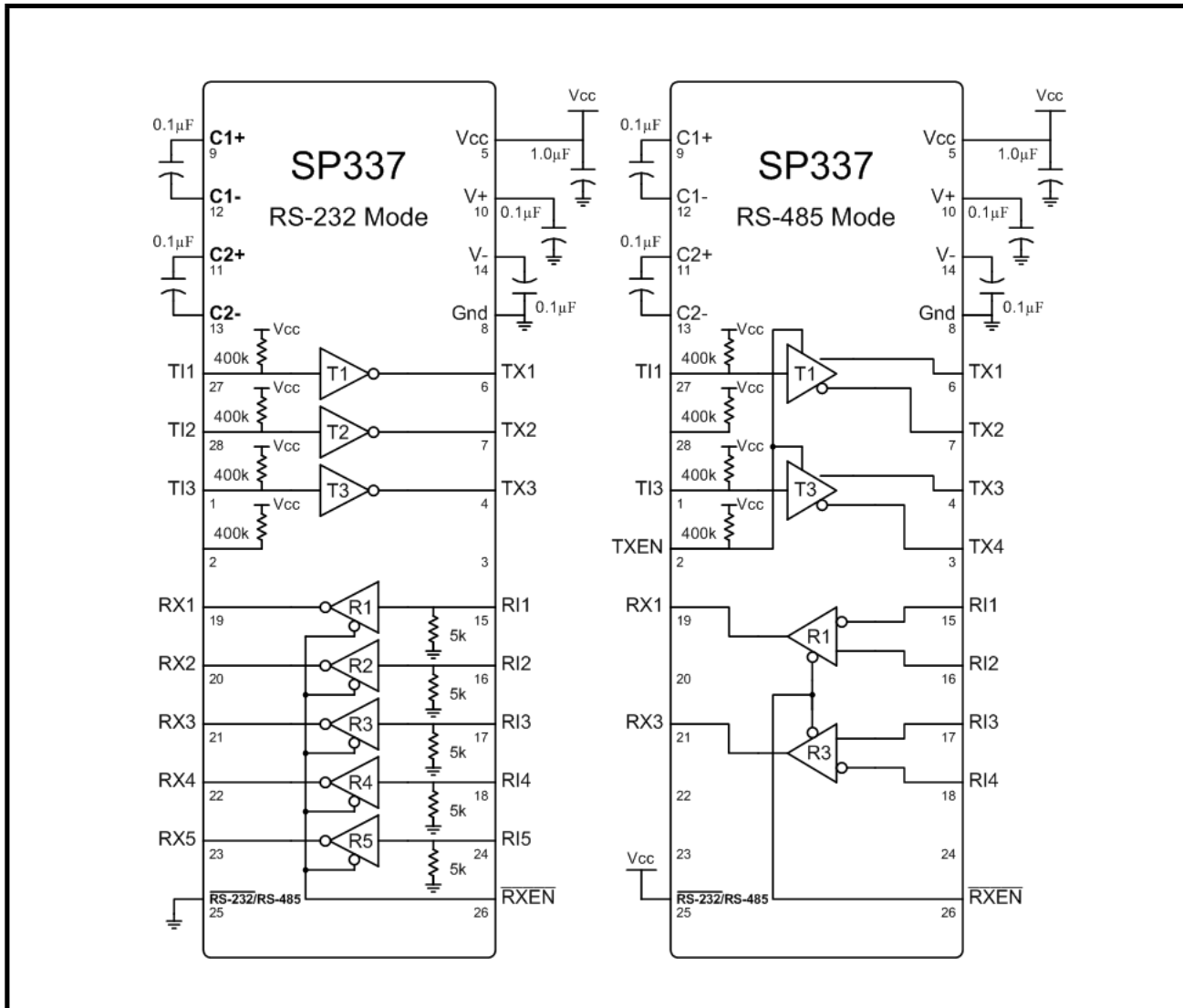
3.3V TO 5V RS-232/RS-485/RS-422 MULTIPROTOCOL TRANSCEIVER
FIGURE 1. TYPICAL RS-232 AND RS-485 APPLICATION CIRCUITS

ORDERING INFORMATION

PART NUMBER	OPERATING TEMPERATURE RANGE	PACKAGE	PACKAGING METHOD	LEAD-FREE
SP337EBEY-L	-40°C to +85°C	28-pin TSSOP	Tube	Yes
SP337EBEY-L/TR	-40°C to +85°C	28-pin TSSOP	Tape and Reel	Yes
SP337EUEY-L	-40°C to +85°C	28-pin TSSOP	Tube	Yes
SP337EUEY-L/TR	-40°C to +85°C	28-pin TSSOP	Tape and Reel	Yes
XR21B1420IL28-0A-EVB	The XR21B1420 Evaluation Board includes the SP339E transceiver.			

NOTE: For the most up-to-date ordering information and additional information on environmental rating, go to www.maxlinear.com/SP337.

PIN DESCRIPTIONS

Pin Assignments

PIN #	PIN NAME	TYPE	DESCRIPTION	
			RS-232	RS-485/RS-422
1	T3	Input	T3 Driver TTL input	T3 Driver TTL input
			This pin has a 400k pull-up to Vcc in both RS-232 and RS-485 modes. The pull-up is disabled in the SP337EU shutdown mode.	
2	TXEN	Input	X*	Only RS-485 mode
			This pin has a 400k pull-up to Vcc in both RS-232 and RS-485 modes. The pull-up is disabled in the SP337EU shutdown mode.	
3	TX4	Output	X*	T3(Z) Inverting Output
4	TX3	Output	T3 Driver Output	T3(Y) Non-Inverting Output
5	Vcc	Power	Power Supply Voltage, between 3.3V and 5V	
6	TX1	Output	T1 Driver Output	T1(Y) Non-Inverting Output
7	TX2	Output	T2 Driver Output	T1(Z) Inverting Output
8	GND	Power	Ground	
9	C1+	Pump	Positive Terminal of Positive Flying Capacitor	
10	V+	Pump	Vdd Storage Capacitor	
11	C2+	Pump	Positive Terminal of Negative Flying Capacitor	
12	C1-	Pump	Negative Terminal of Positive Flying Capacitor	
13	C2-	Pump	Negative Terminal of Negative Flying Capacitor	
14	V-	Pump	Vss Storage Capacitor	
15	RI1	Input	R1 Receiver Input, 5k pull-down	R1(B) Receiver Inverting Input
16	RI2	Input	R2 Receiver Input, 5k pull-down	R1(A) Receiver Non-Inverting Input
17	RI3	Input	R3 Receiver Input, 5k pull-down	R3(A) Receiver Non-Inverting Input
18	RI4	Input	R4 Receiver Input, 5k pull-down	R3(B) Receiver Inverting Input
19	RX1	Output	R1 Receiver Output	
20	RX2	Output	R2 Receiver Output	X*
21	RX3	Output	R3 Receiver Output	
22	RX4	Output	R4 Receiver Output	X*
23	RX5	Output	R5 Receiver Output	X*
24	RI5	Input	R5 Receiver Input, 5k pull-down	X*
25	RS232/RS485	Input	Mode select, either RS-232 (low) or RS-485/422 (high) mode	
26	RXEN	Input	Receiver enable for both RS-232 and RS-485/422 mode (Active low)	

Pin Assignments

PIN #	PIN NAME	TYPE	DESCRIPTION	
			RS-232	RS-485/RS-422
27	T11	Input	T1 Driver Input	T1 Driver Input
			This pin has a 400k pull-up to V _{CC} in both RS-232 and RS-485 modes. The pull-up is disabled in the SP337EU shutdown mode.	
28	T12	Input	T2 Driver Input	X*
			This pin has a 400k pull-up to V _{CC} in both RS-232 and RS-485 modes. The pull-up is disabled in the SP337EU shutdown mode.	

* Pins marked with an X in the above table are ignored or "don't care" in the listed mode, provided they do not exceed V_{CC} or go below ground. Some of these pins have a pull-up to V_{CC} which remains active in both RS-232 and RS-485 mode, but is disabled in the SP337EU shutdown mode.

ABSOLUTE MAXIMUM RATINGS

These are stress ratings only and functional operation of the device at these ratings or any other above those indicated in the operation sections to the specifications below is not implied. Exposure to absolute maximum rating conditions for extended periods of time may affect reliability and cause permanent damage to the device.

Supply Voltage V_{CC}	+6.0V
Receiver Input V_{IN} (DC Input Voltage)	-16V to +16V
Input Voltage at TTL input Pins	-0.3V to $V_{CC} + 0.5V$
Driver Output Voltage (from Ground)	-7.5V to +12.5V
Short Circuit Duration, TXout to GND	Continuous
Storage Temperature Range	-65°C to +150°C
Lead Temperature (soldering, 10s)	+300°C
Power Dissipation 28-pin TSSOP (derate 12mW/°C above +70°C)	657mW
ESD Ratings	
HBM - Human Body Model (TX and RI Pins 3, 4, 6, 7, 15, 16, 17, 18, 24)	±15kV
HBM - Human Body Model (all other pins)	± 2kV
IEC 61000-4-2 Airgap Discharge (TX & RI Pins)	±15kV
IEC 61000-4-2 Contact Discharge (TX & RI Pins)	± 8kV

CAUTION:

ESD (Electrostatic Discharge) sensitive device. Permanent damage may occur on unconnected devices subject to high energy electrostatic fields. Unused devices must be stored in conductive foam or shunts. Personnel should be properly grounded prior to handling this device. The protective foam should be discharged to the destination socket before devices are removed.

ELECTRICAL CHARACTERISTICS

UNLESS OTHERWISE NOTED: $V_{CC} = +3.3V \pm 5\%$ OR $+5.0V \pm 5\%$, C1-C4 = 0.1µF; $T_A = T_{MIN}$ TO T_{MAX} .

TYPICAL VALUES ARE AT $V_{CC} = 3.3V$, $T_A = +25^\circ C$.

SYMBOL	PARAMETERS	MIN.	TYP.	MAX.	UNITS	CONDITIONS
DC CHARACTERISTICS						
I_{CC}	Supply Current (RS-232)		1.5	6.0	mA	No Load, RS232/RS485 = 0V
I_{CC}	Supply Current (RS-485)		7.0	15	mA	No Load, RS232/RS485 = V_{CC}
I_{CC}	V_{CC} Shutdown Current (SP337EU only)		1.0	10.0	µA	TXEN = 0V, RXEN = V_{CC} (SP337EU only)
TRANSMITTER and LOGIC INPUT PINS: Pins 1, 2, 25, 26, 27, 28						
V_{IH}	Logic Input Voltage HIGH	2.0			V	$V_{CC} = 3.3V$
V_{IH}	Logic Input Voltage HIGH	2.4			V	$V_{CC} = 5.0V$
V_{IL}	Logic Input Voltage LOW			0.8	V	
I_{IL}	Logic Input Leakage Current			1.0	µA	Input High ($V_{IN} = V_{CC}$)
I_{PU}	Logic Input Pull-up Current			15.0	µA	Input Low ($V_{IN} = 0V$)
V_{HYS}	Logic Input Hysteresis		0.5		V	

3.3V TO 5V RS-232/RS-485/RS-422 MULTIPROTOCOL TRANSCEIVER

 UNLESS OTHERWISE NOTED: $V_{CC} = +3.3V \pm 5\%$ OR $+5.0V \pm 5\%$, $C1-C4 = 0.1\mu F$; $T_A = T_{MIN}$ TO

 T_{MAX} . TYPICAL VALUES ARE AT $V_{CC} = 3.3V$, $T_A = +25^\circ C$.

SYMBOL	PARAMETERS	MIN.	TYP.	MAX.	UNITS	CONDITIONS
RS-232 and RS-485/422 RECEIVER OUTPUTS: Pins 19, 20, 21, 22, 23						
V_{OH}	Receiver Output Voltage HIGH	$V_{CC}-0.6$			V	$I_{OUT} = 1.0mA$
V_{OL}	Receiver Output Voltage LOW			0.4	V	$I_{OUT} = -3.2mA$
I_{OSS}	Receiver Output ShortCircuit Current		± 40	± 65	mA	$0 < V_O < V_{CC}$
I_{OZ}	Receiver Output Leakage Current		± 0.1	± 1.5	μA	Receivers Disabled
SINGLE-ENDED RECEIVER INPUTS (RS-232)						
	Input Voltage Range	-15		+15	V	
	Input Threshold Low	0.6	1.2		V	$V_{CC} = 3.3V$
		0.8	1.5		V	$V_{CC} = 5.0V$
	Input Threshold HIGH		1.5	2.0	V	$V_{CC} = 3.3V$
			1.8	2.4	V	$V_{CC} = 5.0V$
	Input Hysteresis		0.5		V	
	Input Resistance	3	5	7	$k\Omega$	
DIFFERENTIAL RECEIVER INPUTS (RS-485 / RS-422)						
R_{IN}	Receiver Input Resistance	96			$k\Omega$	$-7V \leq V_{CM} \leq +12V$
V_{TH}	Receiver Differential Threshold	-200	-125	-50	mV	
ΔV_{TH}	Receiver Input Hysteresis		30		mV	$V_{CM} = 0V$
I_{IN}	Input Current			125	μA	$V_{IN} = 12V$
				-100	μA	$V_{IN} = -7V$
SINGLE-ENDED DRIVER OUTPUTS (RS-232)						
V_O	Output Voltage Swing	± 5.0	± 5.4		V	Output Loaded with $3k\Omega$ to Gnd
				± 7.0	V	No Load Output
	Short Circuit Current			± 60	mA	$V_O = 0V$
	Power Off Impedance	300	10M		Ω	$V_{CC} = 0V$; $V_O = \pm 2V$
DIFFERENTIAL DRIVER OUTPUTS (RS-485 / RS-422)						
V_{OD}	Differential Driver Output (Tx_Out)	2		V_{CC}	V	$R_L = 100\Omega$ (RS-422), Figure 2
		1.5		V_{CC}	V	$R_L = 54\Omega$ (RS-485), Figure 2
		1.5		V_{CC}	V	$V_{CM} = -7V$, Figure 3
		1.5		V_{CC}	V	$V_{CM} = +12V$, Figure 3
ΔV_{OD}	Change In Magnitude of Differential Output Voltage	-0.2		+0.2	V	$R_L = 54\Omega$ or 100Ω , Figure 2
V_{OC}	Driver CommonMode Output Voltage			3	V	$R_L = 54\Omega$ or 100Ω , Figure 2
ΔV_{OC}	Change In Magnitude of Common Mode Output Voltage			0.2	V	$R_L = 54\Omega$ or 100Ω , Figure 2

3.3V TO 5V RS-232/RS-485/RS-422 MULTIPROTOCOL TRANSCEIVER

 UNLESS OTHERWISE NOTED: $V_{CC} = +3.3V \pm 5\%$ OR $+5.0V \pm 5\%$, $C1-C4 = 0.1\mu F$; $T_A = T_{MIN}$ TO T_{MAX} .

 TYPICAL VALUES ARE AT $V_{CC} = 3.3V$, $T_A = +25^\circ C$.

SYMBOL	PARAMETERS	MIN.	TYP.	MAX.	UNITS	CONDITIONS
I_{OSD}	Driver Output Short Circuit Current			± 250	mA	$V = +12V$ to $-7V$, Figure 4
I_O	Output Leakage Current			± 100	μA	TXEN = 0V or Shutdown, $V_O = +12V$ to $-7V$, $V_{CC} = 0V$ or $5.25V$
TIMING CHARACTERISTICS						
RS-232 (SP337EB ONLY) DATA RATE = 250kbps, ONE TRANSMITTER SWITCHING						
	Maximum Data Rate	250			kbps	$R_L = 3k\Omega$, $C_L = 1000pF$
t_{PHL}, t_{PLH}	Receiver Propagation Delay		100		ns	$C_L = 150pF$, Figures 20 and 21
$ t_{PHL} - t_{PLH} $	Receiver Skew			100	ns	$C_L = 150pF$, Figures 20 and 21
t_{PHL}, t_{PLH}	Driver Propagation Delay		800		ns	
$ t_{PHL} - t_{PLH} $	Driver Skew			400	ns	
	Receiver Output Enable time			400	ns	
	Receiver Output Disable time			400	ns	
t_{THL}, t_{TLH}	Transition-Region Slew Rate from $+3.0V$ to $-3.0V$ or $-3.0V$ to $+3.0V$	4		30	V/ μs	$V_{CC} = 3.3V$, $R_L = 3k\Omega$ to $7k\Omega$, $C_L = 150pF$ to $2500pF$, Figures 18 and 19
RS-232 (SP337EU ONLY) DATA RATE = 1Mbps, ONE TRANSMITTER SWITCHING						
	Maximum Data Rate	1			Mbps	$R_L = 3k\Omega$, $C_L = 250pF$
t_{PHL}, t_{PLH}	Receiver Propagation Delay		100		ns	$C_L = 150pF$, Figures 20 and 21
$ t_{PHL} - t_{PLH} $	Receiver Skew			100	ns	$C_L = 150pF$, Figures 20 and 21
t_{PHL}, t_{PLH}	Driver Propagation Delay		250		ns	
$ t_{PHL} - t_{PLH} $	Driver Skew			150	ns	
	Receiver Output Enable time			400	ns	
	Receiver Output Disable time			400	ns	
t_{THL}, t_{TLH}	Transition-Region Slew Rate from $+3.0V$ to $-3.0V$ or $-3.0V$ to $+3.0V$	50			V/ μs	$V_{CC} = 3.3V$, $R_L = 3k\Omega$, $C_L = 150pF$, Figures 18 and 19
RS-485/RS-422 (SP337EB and SP337EU) DATA RATE = 15Mbps, ONE TRANSMITTER SWITCHING						
	Maximum Data Rate	15	20		Mbps	$R_{DIFF} = 54\Omega$, $C_L = 50pF$
t_{DPHL}, t_{DPLH}	Differential Output Propagation Delay Time		60	120	ns	Figures 5 and 6
t_R, t_F	Driver Rise and Fall Time		15	25	ns	Figures 5 and 6
$ t_{DPHL} - t_{DPLH} $	Driver Propagation Delay Skew			10	ns	Figures 5 and 6
t_{DZH}, t_{DZL}	Driver Output Enable Time			400	ns	Figures 7, 8, 9 and 10
t_{DHZ}, t_{DLZ}	Driver Output Disable Time			400	ns	Figures 7, 8, 9 and 10
t_{PHL}, t_{PLH}	Receiver Propagation Delay		80	150	ns	Figures 11 and 12

3.3V TO 5V RS-232/RS-485/RS-422 MULTIPROTOCOL TRANSCEIVER

UNLESS OTHERWISE NOTED: $V_{CC} = +3.3V \pm 5\%$ OR $+5.0V \pm 5\%$, $C1-C4 = 0.1\mu F$; $T_A = T_{MIN}$ TO T_{MAX} . TYPICAL VALUES ARE AT $V_{CC} = 3.3V$, $T_A = +25^\circ C$.

SYMBOL	PARAMETERS	MIN.	TYP.	MAX.	UNITS	CONDITIONS
t_{ZH}	Receiver Enable to Output High		100	200	ns	Figures 13 and 14
t_{ZL}	Receiver Enable to Output Low		100	200	ns	Figures 13 and 15
t_{HZ}	Receiver Output High to Disable		100	200	ns	Figures 13 and 16
t_{LZ}	Receiver Output Low to Disable		100	200	ns	Figures 13 and 17
RS-485/RS-422 SHUTDOWN FEATURE APPLIES TO SP337EU ONLY						
t_{DZZV}	Shutdown n to Driver Output Valid			30	μs	
$t_{Dshutdw_n}$	Driver Time to Shutdown n		100		ns	
t_{RZZV}	Shutdown n to Receiver Output Valid			30	μs	
$t_{Rshutdw_n}$	Receiver Time to Shutdown n		100		ns	

FIGURE 2. RS-485 DRIVER DC TEST CIRCUIT

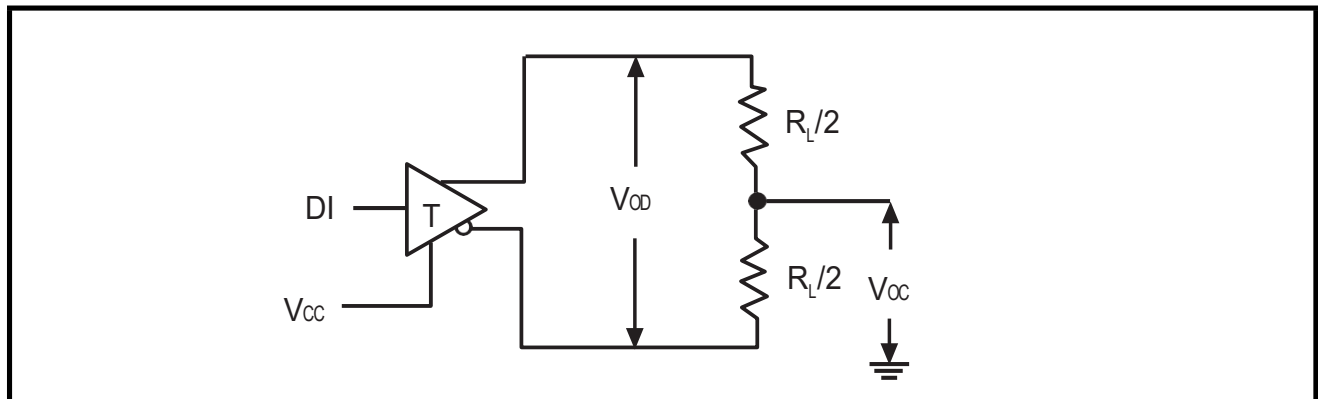

FIGURE 3. RS-485 DRIVER COMMON MODE LOAD TEST

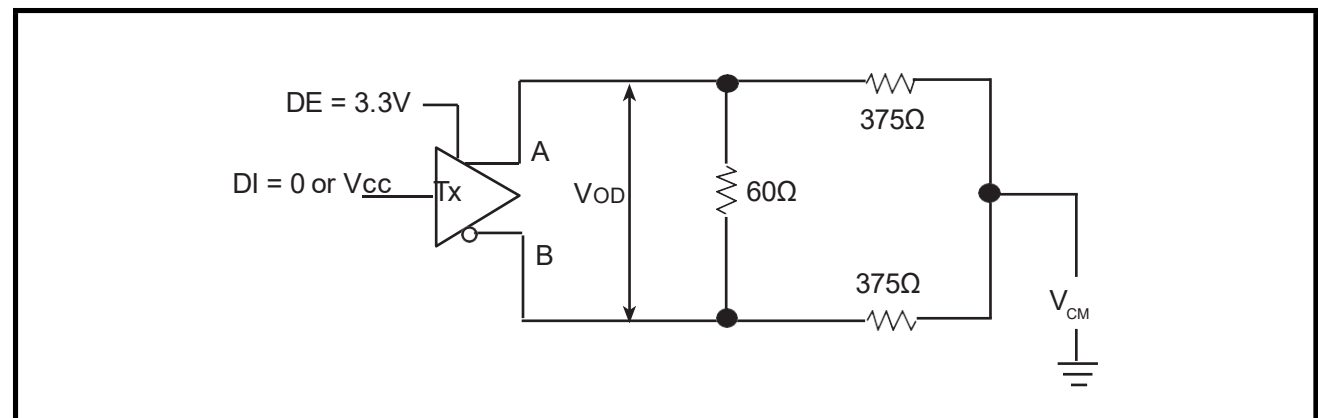

FIGURE 4. RS-485 DRIVER OUTPUT SHORT CIRCUIT TEST

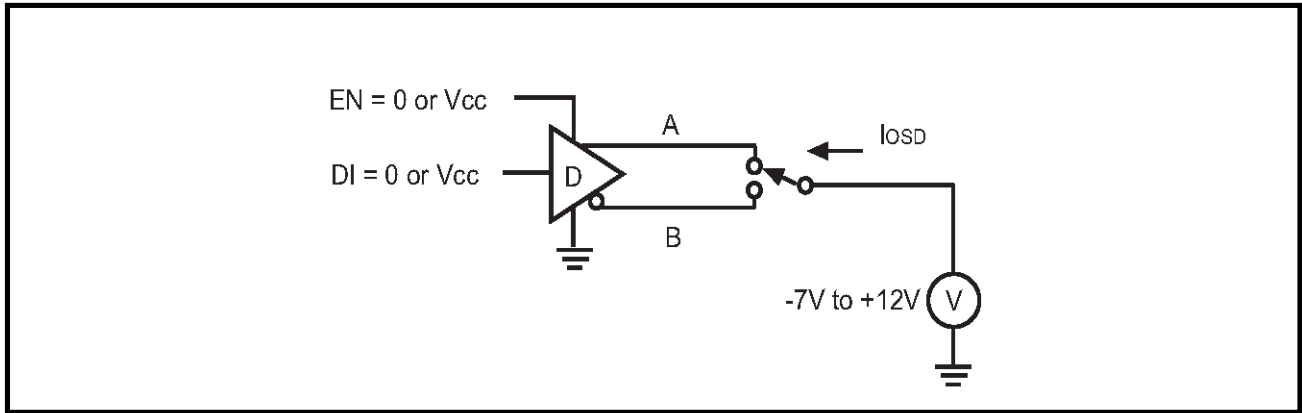

FIGURE 5. RS-485 DRIVER PROPAGATION DELAY TEST CIRCUIT

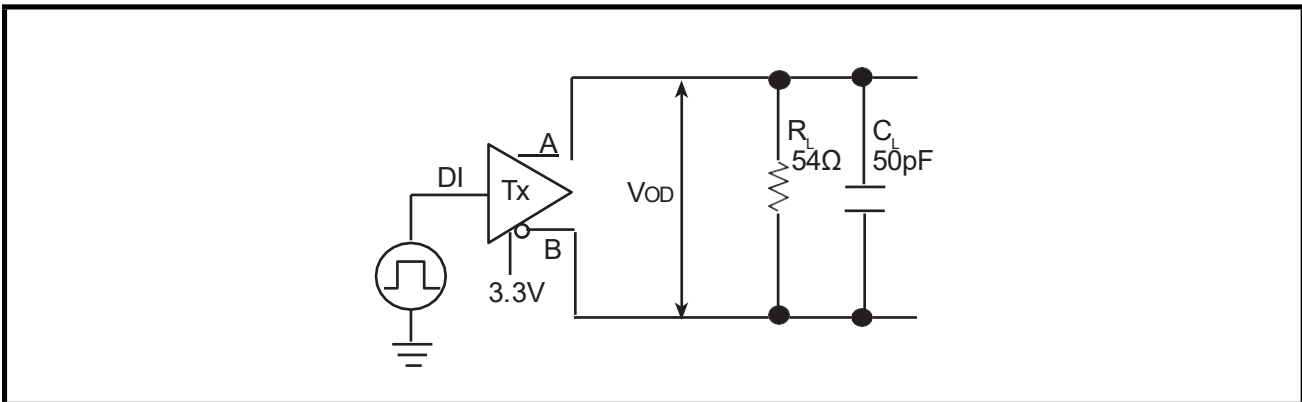

FIGURE 6. RS-485 DRIVER TIMING DIAGRAM

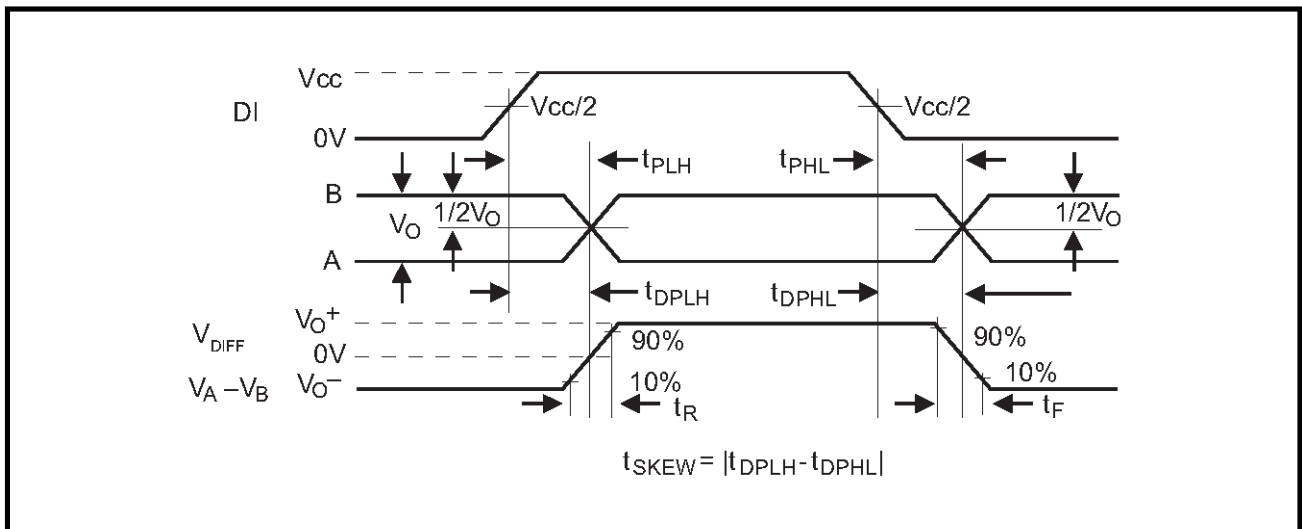

FIGURE 7. RS-485 DRIVER ENABLE AND DISABLE TEST CIRCUIT

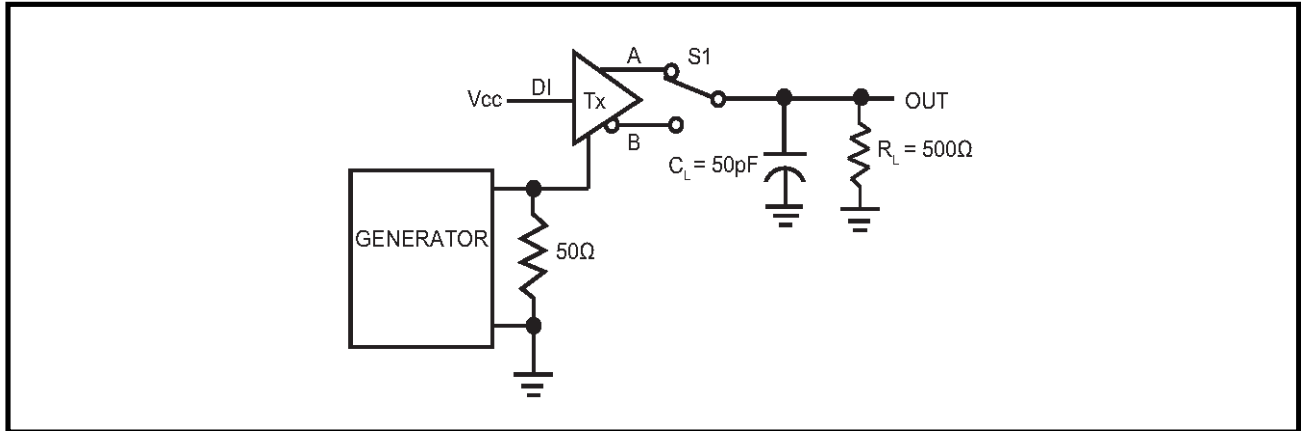

FIGURE 8. RS-485 DRIVER ENABLE AND DISABLE TIMING DIAGRAM

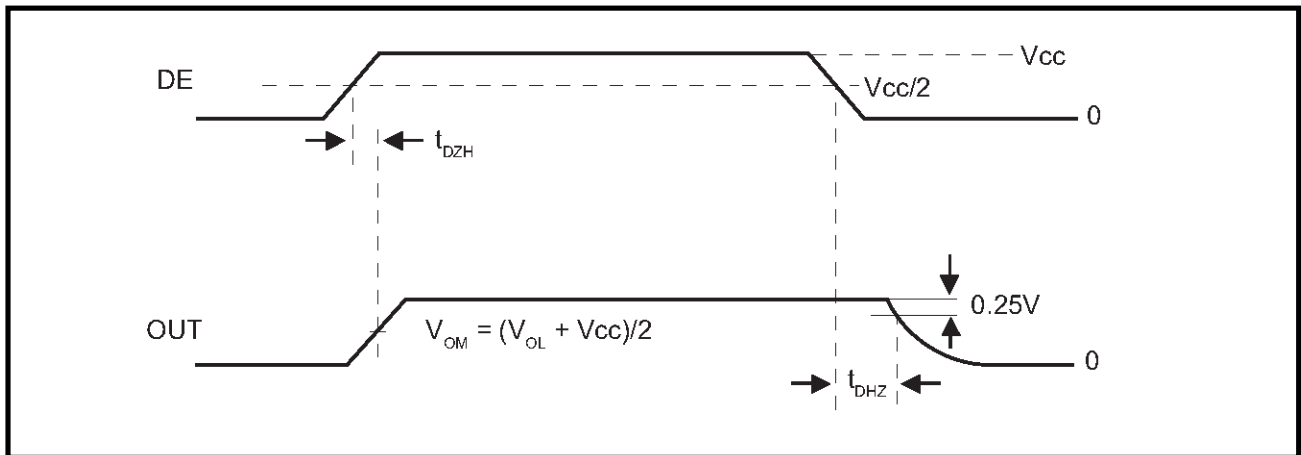

FIGURE 9. RS-485 DRIVER ENABLE AND DISABLE TEST CIRCUIT 2

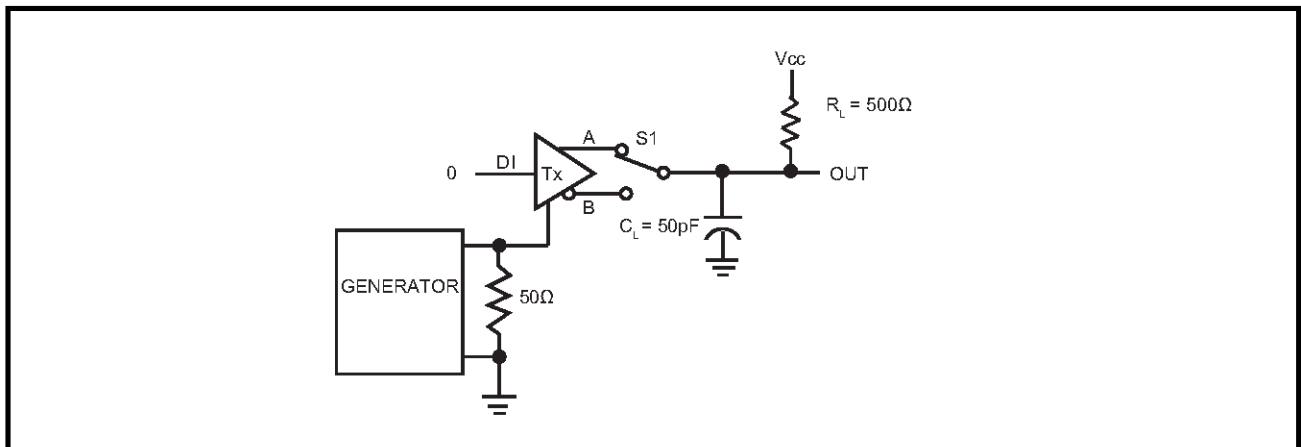

FIGURE 10. RS-485 DRIVER ENABLE AND DISABLE TIMING DIAGRAM 2

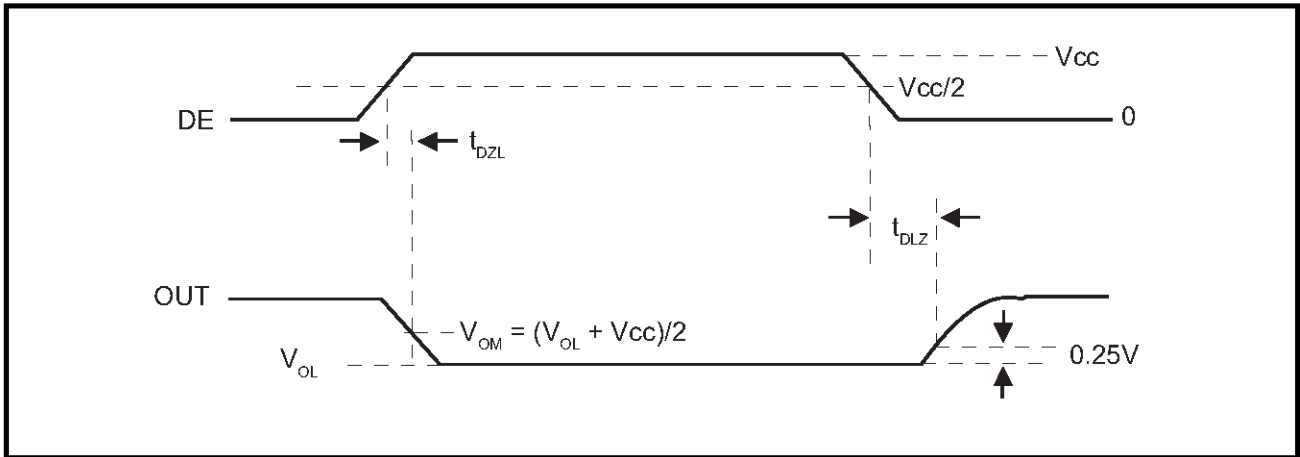

FIGURE 11. RS-485 RECEIVER PROPAGATION DELAY TEST CIRCUIT

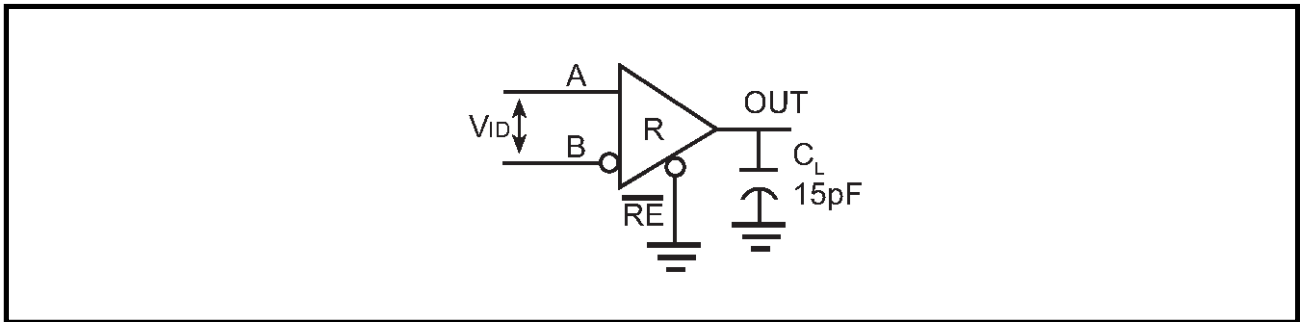

FIGURE 12. RS-485 RECEIVER PROPAGATION DELAY TIMING DIAGRAM

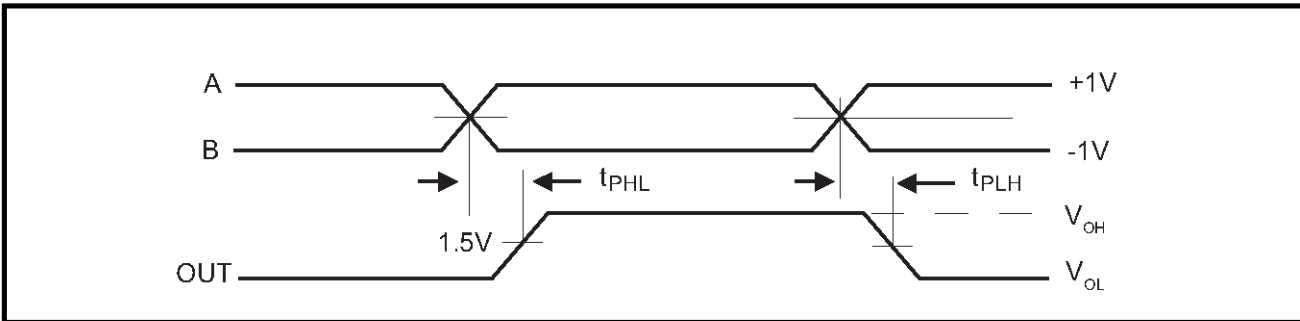

FIGURE 13. RS-485 RECEIVER ENABLE AND DISABLE TIMES TEST CIRCUIT

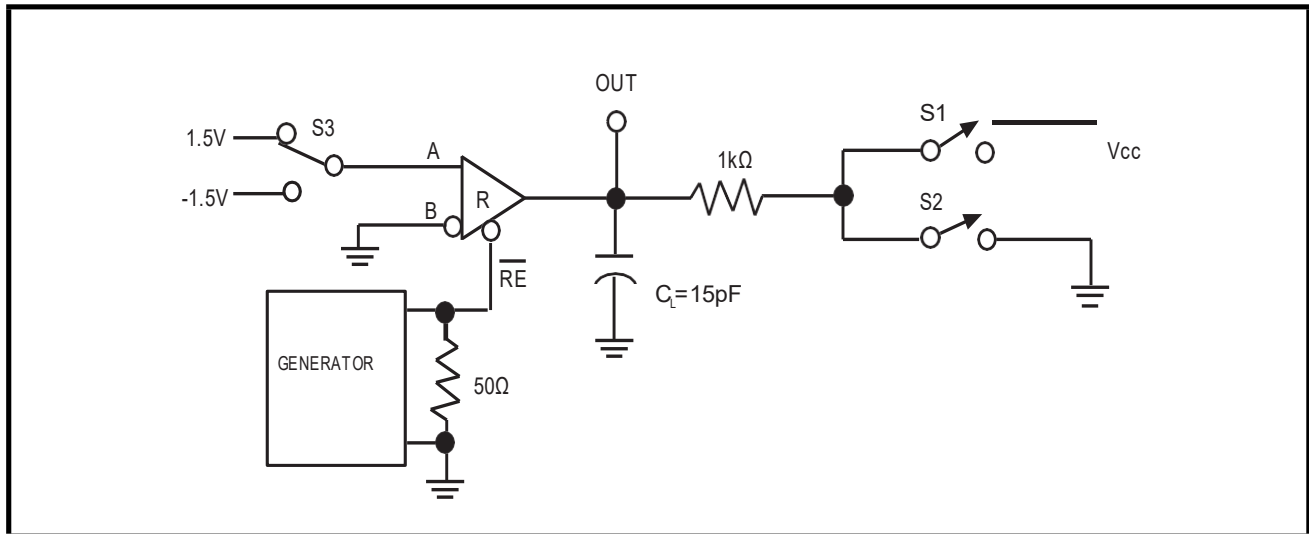

FIGURE 14. RS-485 RECEIVER ENABLE AND DISABLE TIMES TIMING DIAGRAM 1

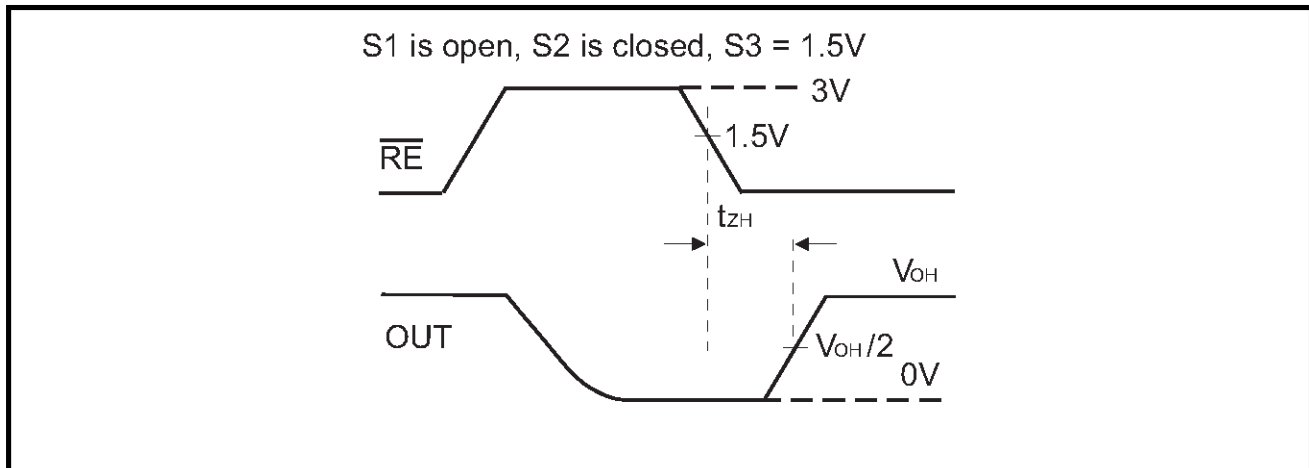

FIGURE 15. RS-485 RECEIVER ENABLE AND DISABLE TIMES TIMING DIAGRAM 2

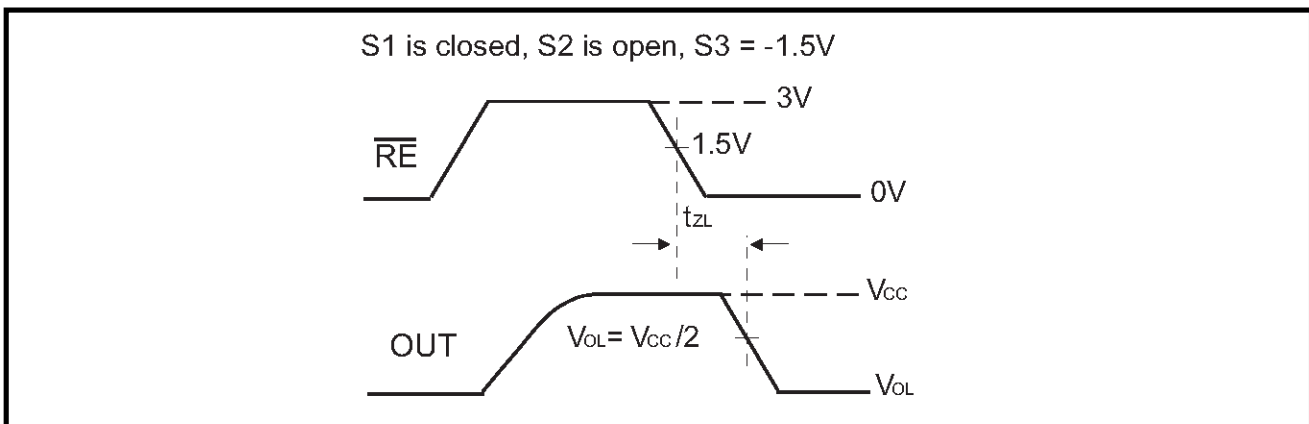

FIGURE 16. RS-485 RECEIVER ENABLE AND DISABLE TIMES TIMING DIAGRAM 3

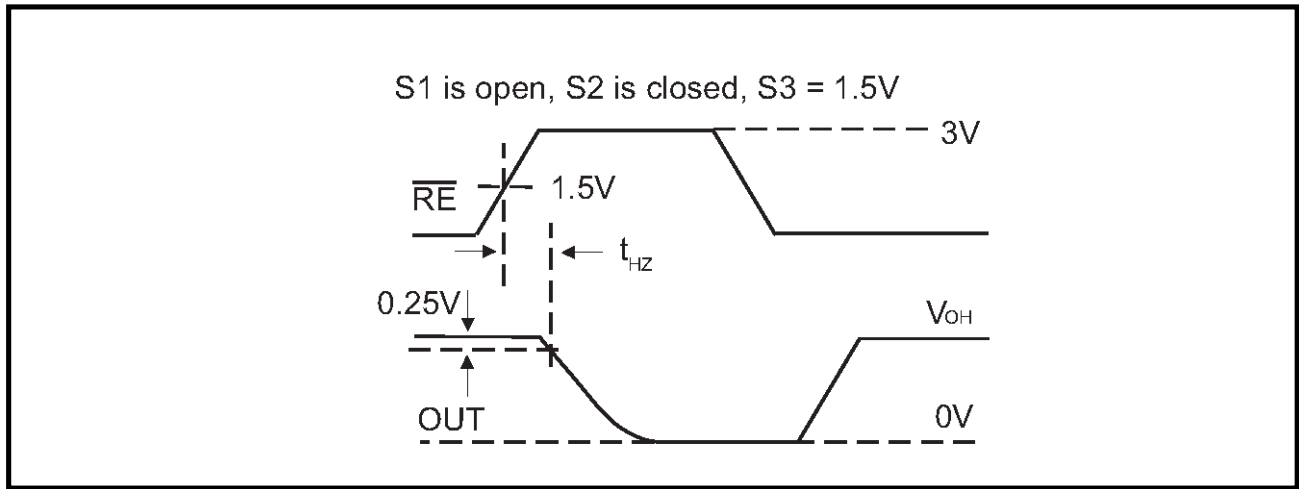

FIGURE 17. RS-485 RECEIVER ENABLE AND DISABLE TIMES TIMING DIAGRAM 4

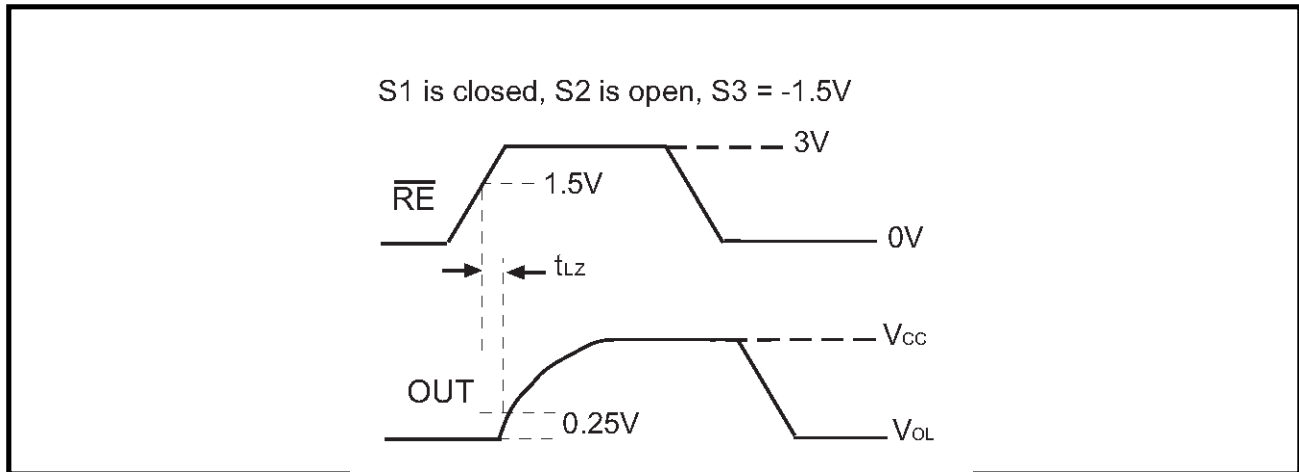

FIGURE 18. RS-232 DRIVER OUTPUT SLEW RATE TEST CIRCUIT

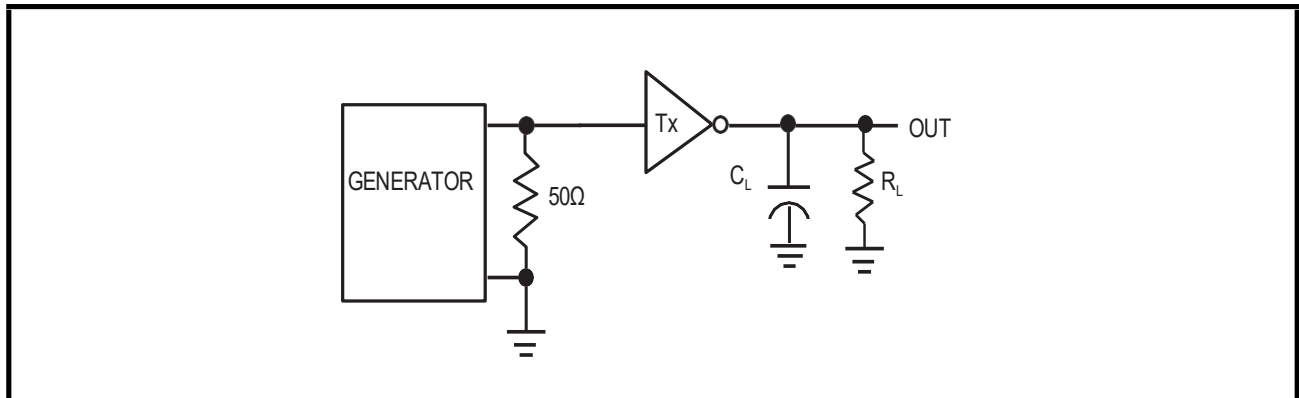

FIGURE 19. RS-232 DRIVER OUTPUT SLEW RATE TIMING DIAGRAM

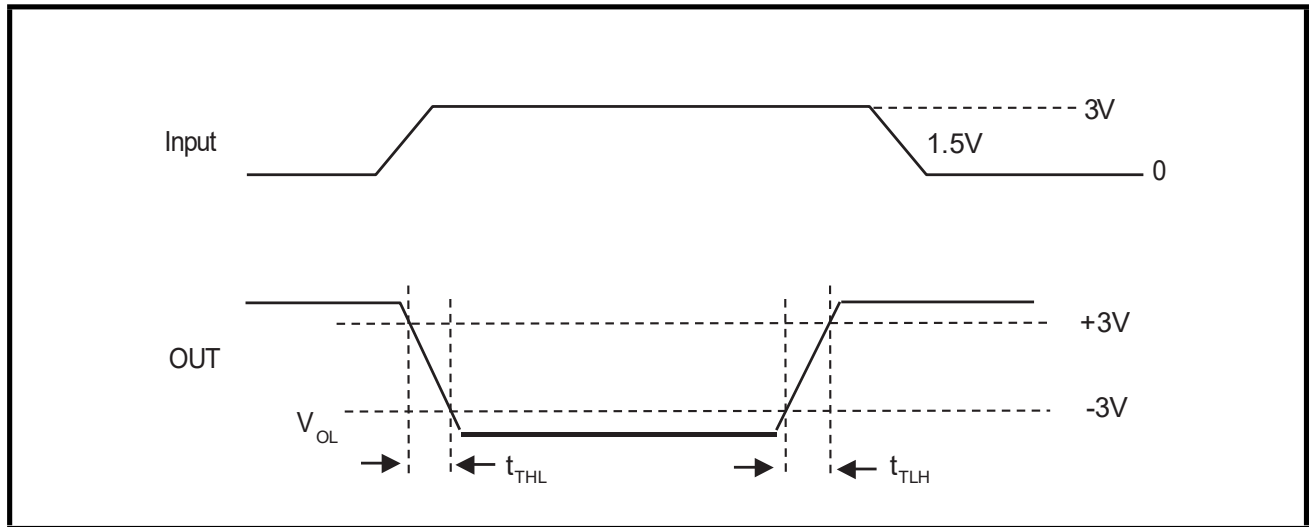

FIGURE 20. RS-232 RECEIVER PROPAGATION DELAY TEST CIRCUIT

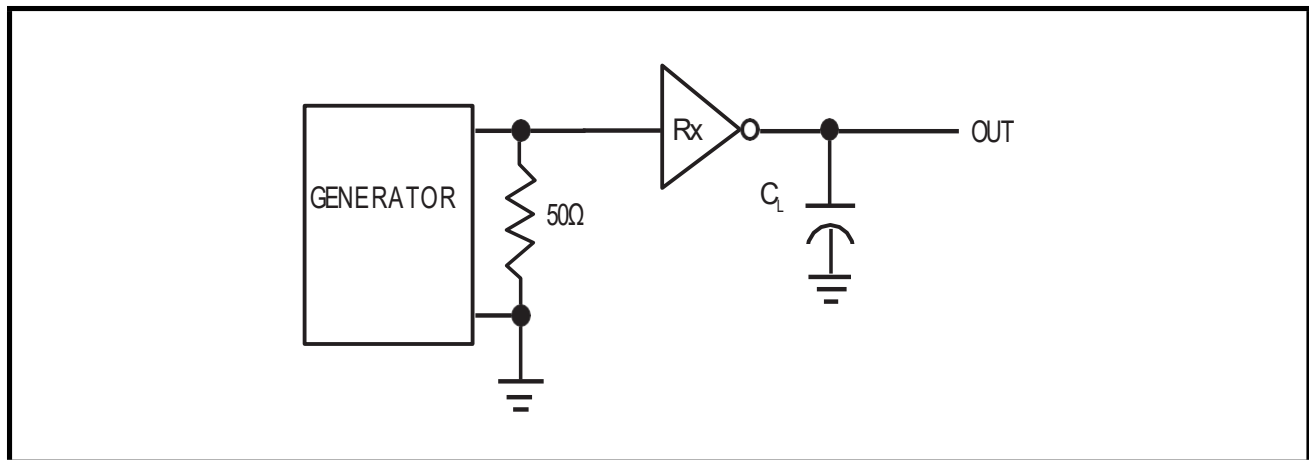
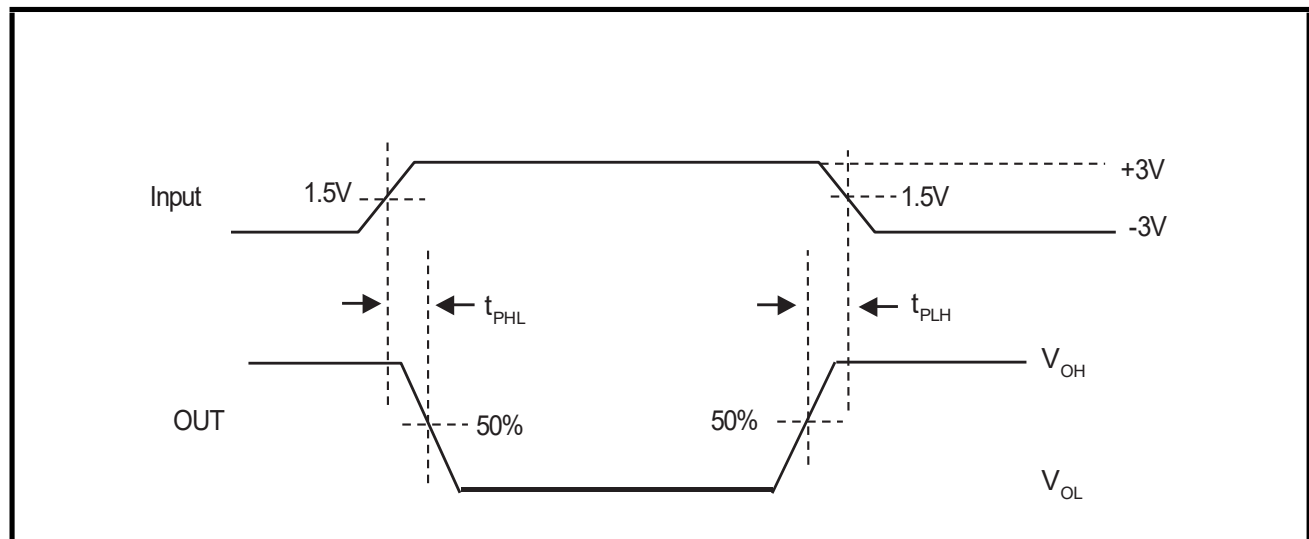

FIGURE 21. RS-232 RECEIVER PROPAGATION DELAY TIMING DIAGRAM



SP337E Mode Configuration Tables
TABLE 1: SP337EB

$\overline{\text{RS232/RS485}}$	TXEN	$\overline{\text{RXEN}}$	Operation		Charge Pump	Driver and Receiver
Low	Ignored	Low	RS-232	3T/5R	ON	Receivers Enabled
Low	Ignored	High	RS-232	3T/5R	ON	Receivers Disabled (High-Z Output)
High	Low	Low	RS-485/422 Full-Duplex	2T/2R	ON	Drivers Disabled (High-Z Output); Receivers Enabled
High	High	High	RS-485/422 Full-Duplex	2T/2R	ON	Drivers Enabled; Receivers Disabled (High-Z Output)
High	Low	High	RS-485/422 Full-Duplex	2T/2R	ON	Drivers Disabled (High Z output); Receivers Disabled (High Z output)
High	High	Low	RS-485/422 Full-Duplex	2T/2R	ON	Drivers Enabled; Receivers Enabled

TABLE 2: SP337EU

$\overline{\text{RS232/RS485}}$	TXEN	$\overline{\text{RXEN}}$	Operation		Charge Pump	Driver and Receiver
Low	Ignored	Low	RS-232	3T/5R	ON	Receivers Enabled
Low	Ignored	High	RS-232	3T/5R	ON	Receivers Disabled (High-Z Output)
High	Low	Low	RS-485/422 Full-Duplex	2T/2R	ON	Drivers Disabled (High-Z Output); Receivers Enabled
High	High	High	RS-485/422 Full-Duplex	2T/2R	ON	Drivers Enabled; Receivers Disabled (High-Z Output)
High	Low	High	RS-485/422 Full-Duplex	2T/2R	OFF (Shutdown)	Drivers Disabled (High Z output); Receivers Disabled (High Z output)
High	High	Low	RS-485/422 Full-Duplex	2T/2R	ON	Drivers Enabled; Receivers Enabled

FIGURE 22. 28 PIN TSSOP PACKAGE OUTLINE DRAWING

FIGURE 23. 28 PIN TSSOP RECOMMENDED LAND PATTERN AND STENCIL



REVISION HISTORY

DATE	REVISION	DESCRIPTION
December 2010	1.0.0	Production Release.
December 2010	1.0.1	Update ESD Information.
March 2011	1.0.2	Correct Figure 1 RS-485 driver type error.
March 2018	1.0.3	Clarify test conditions for Driver Output Leakage Current on page 7. Corrected power off impedance unit. Update to MaxLinear logo. Update format and Ordering Information. Moved ESD ratings / protection to Absolute Maximum Ratings section.
July 5, 2021	2.0.0	Add missing units for RS-232 driver propagation delays and ESD protection ratings for IEC61000-4-2. Update SP337EB 250kbps conditions, and RS-485 / RS-422 shutdown to driver / receiver output valid timing according to the changes outlined in PCN 20006. Update ordering information and remove obsolete WSOIC version references.

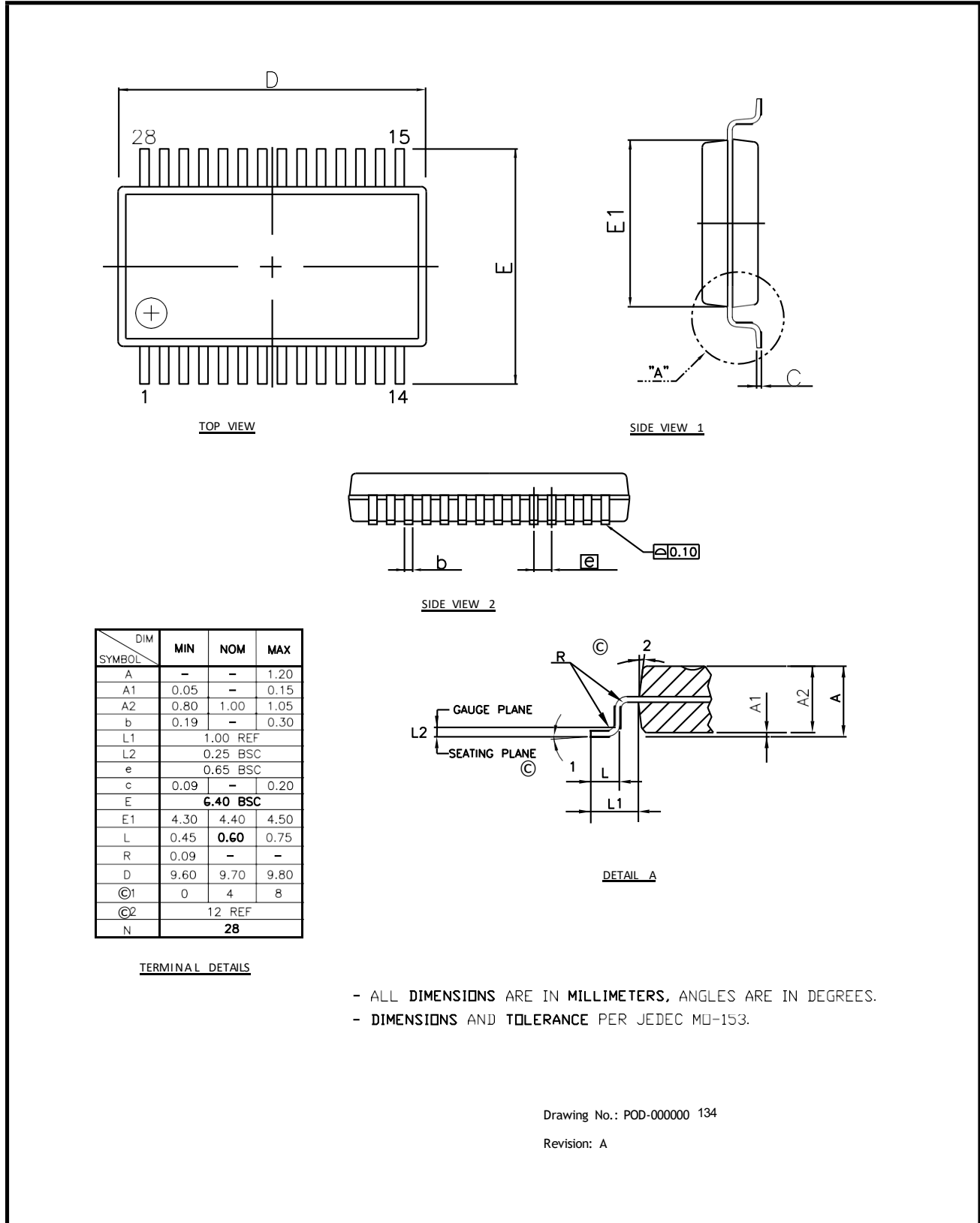
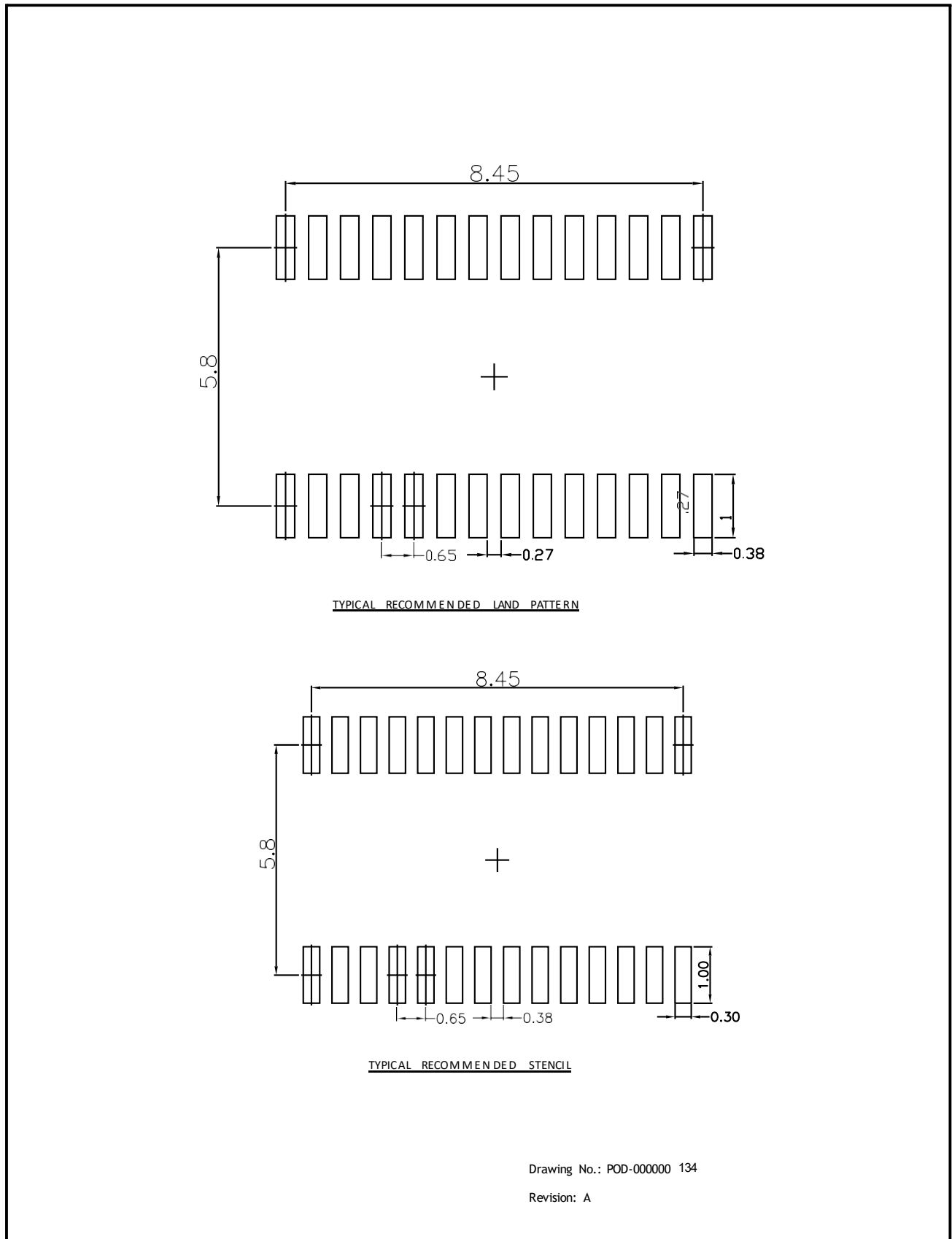
Corporate Headquarters:

5966 La Place Court
 Suite 100
 Carlsbad, CA 92008
 Tel.: +1 (760) 692-0711
 Fax: +1 (760) 444-8598
www.maxlinear.com

The content of this document is furnished for informational use only, is subject to change without notice, and should not be construed as a commitment by MaxLinear, Inc. MaxLinear, Inc. assumes no responsibility or liability for any errors or inaccuracies that may appear in the informational content contained in this guide. Complying with all applicable copyright laws is the responsibility of the user. Without limiting the rights under copyright, no part of this document may be reproduced into, stored in, or introduced into a retrieval system, or transmitted in any form or by any means (electronic, mechanical, photocopying, recording, or otherwise), or for any purpose, without the express written permission of MaxLinear, Inc.

MaxLinear, Inc. does not recommend the use of any of its products in life support applications where the failure or malfunction of the product can reasonably be expected to cause failure of the life support system or to significantly affect its safety or effectiveness. Products are not authorized for use in such applications unless MaxLinear, Inc. receives, in writing, assurances to its satisfaction that: (a) the risk of injury or damage has been minimized; (b) the user assumes all such risks; (c) potential liability of MaxLinear, Inc. is adequately protected under the circumstances.

MaxLinear, Inc. may have patents, patent applications, trademarks, copyrights, or other intellectual property rights covering subject matter in this document. Except as expressly provided in any written license agreement from MaxLinear, Inc., the furnishing of this document does not give you any license to these patents, trademarks, copyrights, or other intellectual property.

MaxLinear, the MaxLinear logo, any MaxLinear trademarks (MxL, Full-Spectrum Capture, FSC, G.now, AirPHY, Puma, and AnyWAN), and the MaxLinear logo on the products sold are all property of MaxLinear, Inc. or one of MaxLinear's subsidiaries in the U.S.A. and other countries. All rights reserved. *Other company trademarks and product names appearing herein are the property of their respective owners.

© 2021 MaxLinear, Inc. All rights reserved.

X-ON Electronics

Largest Supplier of Electrical and Electronic Components

Click to view similar products for [Interface - Specialised category](#):

Click to view products by [MaxLinear manufacturer](#):

Other Similar products are found below :

[CY7C910-51LMB](#) [MEC1632-AUE](#) [RKSAS4](#) [HMC677G32](#) [LPC47N207-JV](#) [FTP-637DSL633R](#) [SM712GX04LF04-BA](#) [MCW1001A-I/SS](#)
[HOA6241-001](#) [SC74HC4066ADTR2G](#) [NCN5120MNTWG](#) [NCN5150DR2G](#) [NCN8025MTTBG](#) [C100N50Z4A](#) [DG407AK/883B](#) [SRT2-ATT01](#) [TDA8035HN/C1/S1J](#) [LTC1694CS5#TRMPBF](#) [DS90UB947TRGCRQ1](#) [SP510ECF-L](#) [NCS2300MUTAG](#) [ADG1404YCPZ-REEL](#)
[HMC677LP5E](#) [HMC677LP5ETR](#) [LTC1756EGN#PBF](#) [LTC1955EUH#PBF](#) [LT3669EUFD-2#PBF](#) [LTC6820HMS#3ZZTRPBF](#)
[MXL1543BCAI](#) [MAX3170CAI+](#) [XL1192D](#) [CP82C59AZ](#) [KTU1109EFAA-TR](#) [CH368L](#) [CH7307C-DEF](#) [LTC1694-1IS5#TRMPBF](#)
[LTC1694CS5#TRPBF](#) [LTC1694IS5#TRM](#) [LTS 25-NP](#) [73S8024RN-20IMF](#) [73S8024RN-IL/F](#) [DS2413P+](#) [DS2413P+T&R](#) [DS28E17Q+](#)
[DS8113-RNG+](#) [MAX13036ATI+](#) [MAX13174ECAG+](#) [MAX216CWN+](#) [MAX3172CAI+](#) [AS8222-HSSM](#)