

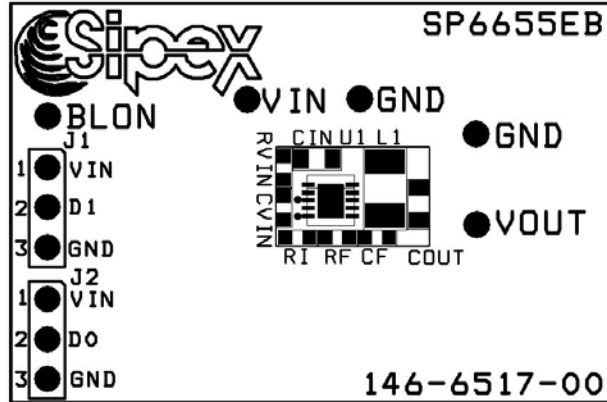

SP6655EB Evaluation Board Manual

- High Efficiency Synchronous Step-Down Converter with up to 98% efficiency
- 400mA Output Current, only 20uA Quiescent Current
- 2.7V-6.5V Input Voltage range, Output Adjustable down to 0.8V
- DFN Package & Ceramic Capacitors for small, low profile Power Supply
- Ideal for PDAs, Digital Cameras, Wireless Modems, Cellular Telephones



DESCRIPTION

The **SP6655 Evaluation Board** is designed to help the user evaluate the performance of the SP6655 for use as a single Li-Ion battery Step-Down DC-DC Converter. The SP6655 operates from 2.7V to 6.5V input, with the highest efficiency in the range 3.0V to 4.2V where the Li-Ion battery has the most energy. The SP6655EB evaluation board is a complete power supply circuit to provide ease of evaluation for the DC/DC Converter performance.

FIGURE 1. SP6655 1.8V OUTPUT EVALUATION BOARD SCHEMATIC

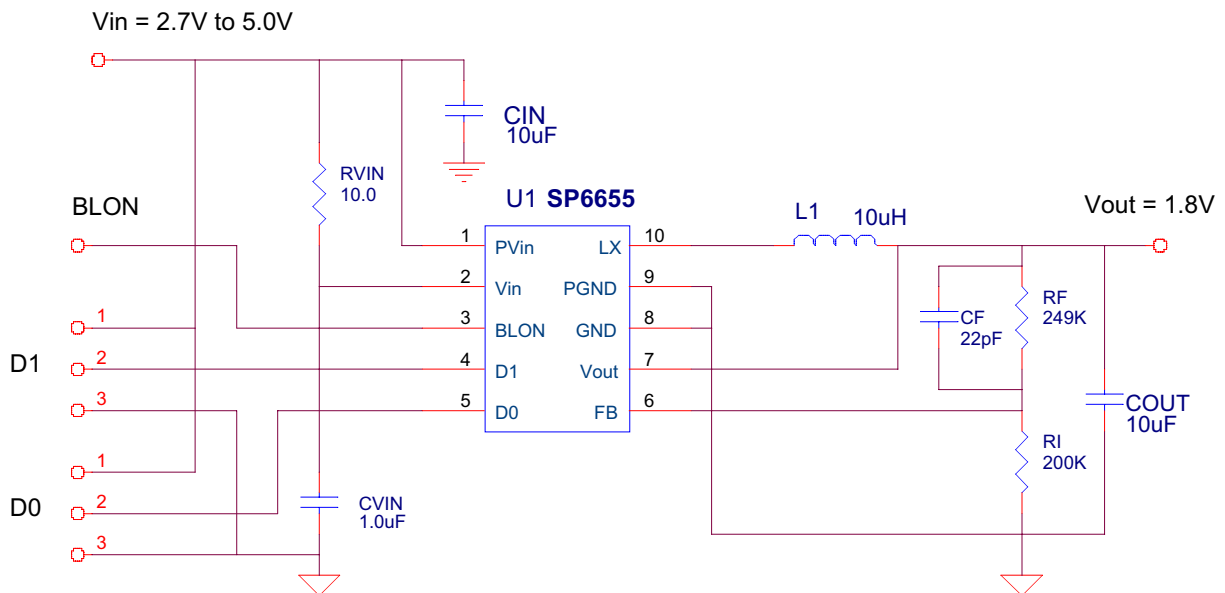

USING THE EVALUATION BOARD

1) Powering up the SP6655 Circuit & Programming the UVLO threshold

The SP6655 Evaluation Board can be powered from a single Li-Ion battery or a +2.7 to +5.0V power supply. Connect with short leads directly to the “Vin” and “Gnd” posts. Note the SP6655 will remain in “shutdown” until D0 or D1 of the Jumpers J1 or J2 are applied to the Vin or position 1 to 2. See Table 1 for UVLO threshold programming and D1 and D0 pin definition.

Table 1. Operating Mode Definition

D1	D0	Definition
0	0	Shutdown. All internal circuitry is disabled and the power switches are opened.
0	1	Device enabled, falling UVLO threshold = 2.70V
1	0	Device enabled, falling UVLO threshold = 2.85V
1	1	Device enabled, falling UVLO threshold = 3.00V

2) VOUT PROGRAMMING

The SP6655 requires 2 feedback resistors to control the output voltage. Connect the appropriate resistors RF and RI (Table 2) from pin 6 SP6655 FB to Vout and to the GND.

For Vout different from that shown in the Table 2, use equation:

$$RF = \left(\frac{V_{out}}{0.8} - 1 \right) \cdot RI$$

Table 2. SP6655UEB BILL OF MATERIALS

Component	Vo = 1.8V
L1	10uH, Murata LQH32CN100K11, 0.3ohm, 0.45A, 1210
CIN	22uF, TDK C2012X5R0J106M, 0.005ohm, 6.3V, X5R, 0805
COU1	22uF, TDK C2012X5R0J106M, 0.005ohm, 6.3V, X5R, 0805
RVIN	10 Ohm 5%, 0603
CVIN	1uF, TDK C1608X5R0J105M, 0.03ohm, .3V, X5R, 0603
RI	200k 1%, 0603
RF	249k 1%, 0603
CF	22pF ceramic, 0603
U1	SP6655ER, 10 pin DFN

Table 3. SP6655 PIN ASSIGNMENT

Pin Name	Pin Description	Pin NO.
PVin	Input voltage power pin. Inductor charging current passes through this pin.	1
Vin	Internal supply voltage. Control circuitry powered from this pin.	2
BLON	Open drain battery low output – need to pullup to supply externally. Vin - Vout below threshold pulls this node to ground. Vin - Vout above threshold, this node is open.	3
D1	Digital mode control input. See Table 1 for definition.	4
D0	Digital mode control input. See Table 1 for definition.	5
FB	External feedback network input connection. Connect a resistor from FB to ground and FB to Vout to control the output voltage. This pin regulates to the internal reference voltage of 0.8V.	6
Vout	Output voltage sense pin. Used for internal timing and BLON circuitry.	7
GND	Internal ground pin. Control circuitry returns current to this pin.	8
PGND	Power ground pin. Synchronous rectifier current returns through this pin.	9
LX	Inductor switching node. Inductor tied between this pin and the output capacitor to create Vout.	10

EVALUATION BOARD LAYOUT

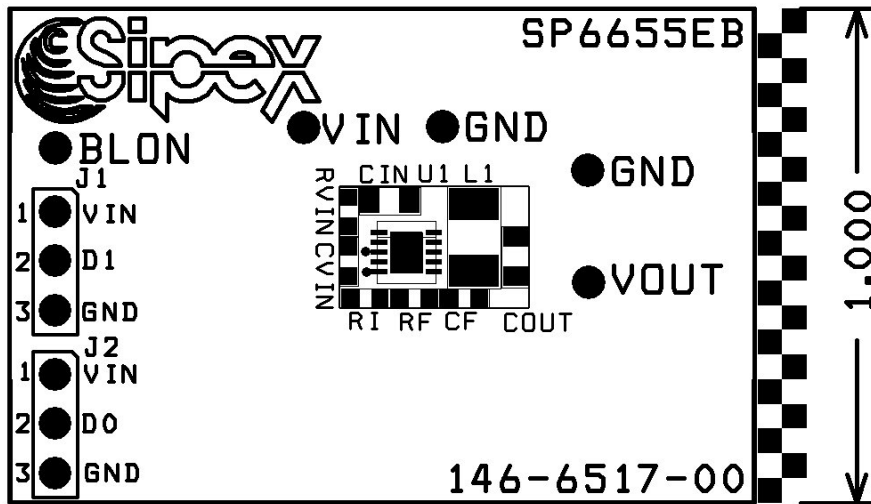

FIGURE 3: SP6655ER COMPONENT PLACEMENT

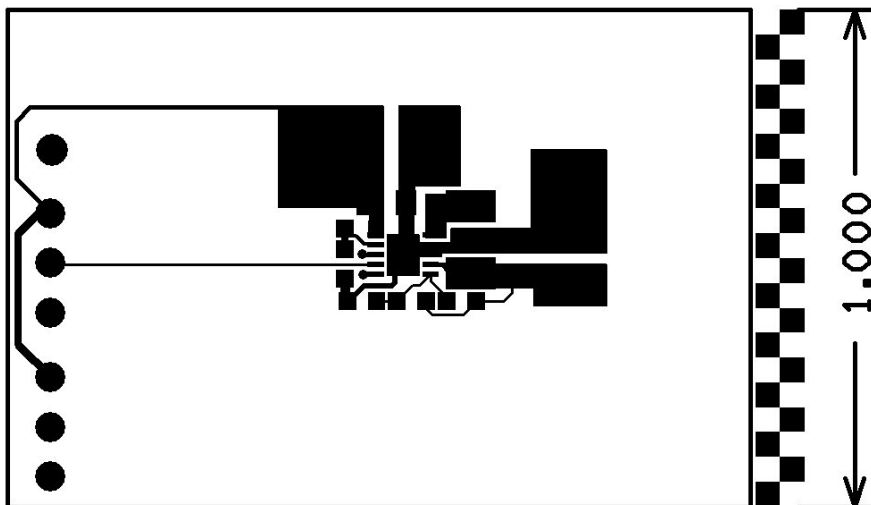

FIGURE 4: SP6655ER PC LAYOUT TOP SIDE

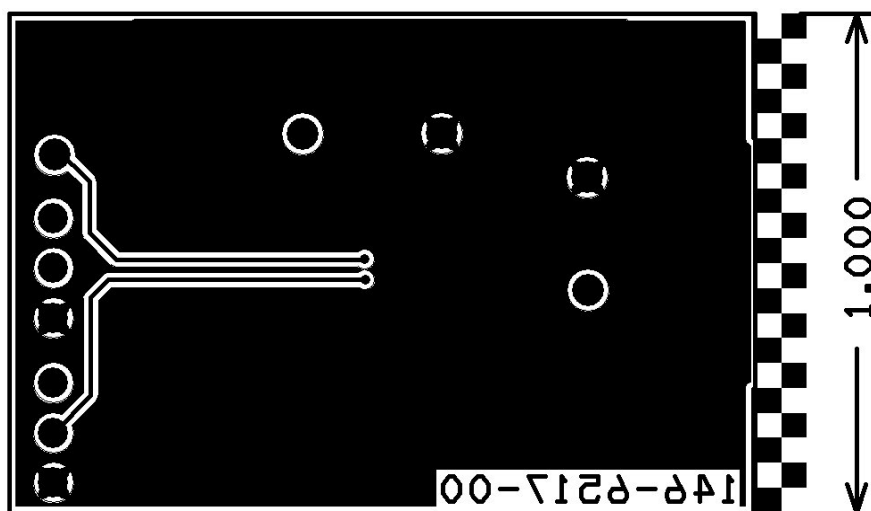

FIGURE 5: SP6655ER PC LAYOUT BOTTOM SIDE

X-ON Electronics

Largest Supplier of Electrical and Electronic Components

Click to view similar products for [Power Management IC Development Tools](#) category:

Click to view products by [Maxlinear](#) manufacturer:

Other Similar products are found below :

[EVAL6482H-DISC](#) [EVAL-AD5522EBUZ](#) [EVAL-ADM1060EBZ](#) [EVAL-ADM1073MEBZ](#) [EVAL-ADM1166TQEBZ](#) [EVAL-ADM1168LQEBZ](#) [EVAL-ADM1171EBZ](#) [EVAL-ADM1276EBZ](#) [EVB-EN5319QI](#) [EVB-EN5365QI](#) [EVB-EN6347QI](#) [EVB-EP5348UI](#) [MIC23158YML EV](#) [MIC23451-AAAYFL EV](#) [MIC5281YMME EV](#) [124352-HMC860LP3E](#) [ADM00513](#) [ADM8611-EVALZ](#) [ADM8612-EVALZ](#) [ADM8613-EVALZ](#) [ADP1046ADC1-EVALZ](#) [ADP1055-EVALZ](#) [ADP122-3.3-EVALZ](#) [ADP130-0.8-EVALZ](#) [ADP130-1.2-EVALZ](#) [ADP130-1.5-EVALZ](#) [ADP130-1.8-EVALZ](#) [ADP160UJZ-REDYKIT](#) [ADP166UJ-EVALZ](#) [ADP1712-3.3-EVALZ](#) [ADP1714-3.3-EVALZ](#) [ADP1715-3.3-EVALZ](#) [ADP1716-2.5-EVALZ](#) [ADP1740-1.5-EVALZ](#) [ADP1752-1.5-EVALZ](#) [ADP1754-1.5-EVALZ](#) [ADP1828LC-EVALZ](#) [ADP1870-0.3-EVALZ](#) [ADP1871-0.6-EVALZ](#) [ADP1873-0.6-EVALZ](#) [ADP1874-0.3-EVALZ](#) [ADP1876-EVALZ](#) [ADP1879-1.0-EVALZ](#) [ADP1882-1.0-EVALZ](#) [ADP1883-0.6-EVALZ](#) [ADP197CB-EVALZ](#) [ADP199CB-EVALZ](#) [ADP2102-1.25-EVALZ](#) [ADP2102-1.2-EVALZ](#) [ADP2102-1.875EVALZ](#)