

3A Ultra Low Dropout Voltage Regulator

Fast Response, Adjustable & Fixed

FEATURES

- Low Dropout Voltage 500mV at 3A Full Load Current
- Adjustable Output Down to 1.25V from ATX Power Supply
- Fixed Output Voltages of 3.3V and 2.5V
- Extremely Tight Load and Line Regulation
- Standard 5-Terminal Low Cost TO-220 and TO-263

APPLICATIONS

- 3.3V to 2.8V ATX Power Supplies
- 3.3V to 2.9V for Portable PENTIUM™ Processor
- 5V to 3.5V VRE Supply
- High efficiency "Green" Computer Systems

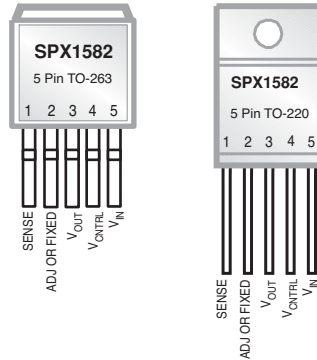

Now Available in Lead Free Packaging

DESCRIPTION

The SPX1582 is a 3A Low Dropout Regulator with extremely low dropout voltage. The adjustable version requires only two external resistors to set the output voltage. The fixed version has a preset output of 3.3V, 2.8V or 2.5V and does not require any external resistors. The SPX1582 features a low dropout of 400mV(Typ.) and offers fast transient response. This device is suitable for Pentium applications requiring 2.8V, 2.5V from 3.3V ATX power supplies, where low current input voltage 1V greater than the output voltage is needed. With an external sense pin the load regulation is less than 1mV. This device is an excellent choice for the use in powering low voltage microprocessors that require a lower dropout, fast transient response to regulate from 3.3V and 5V supplies. The SPX1582 is also an excellent choice as a post regulator for switching supply applications.

The SPX1582 offers protection against over-current faults, reversed input polarity, over temperature operation and positive or negative transient voltages.

The SPX1582 is offered in a 5 pin TO-220 and TO-263 compatible with industry standard 5-terminal regulators. For 5A, 3A and 1.5A ultra low dropout versions refer to SPX1581, SPX1582 and SPX1583 data sheets respectively.

TYPICAL APPLICATIONS CIRCUIT

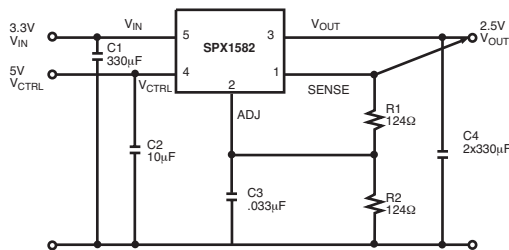

- (1) V_{CTRL} needed when $V_{IN} < 5V$.
- (2) $V_{OUT} = V_{REF} (1 + R_2/R_1) + ADJ \cdot R_2$.
- (3) V_{REF} is measured across adjust to sense.

Adjustable Regulator

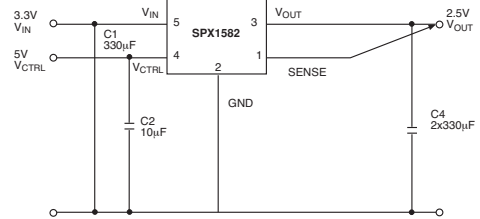

- (1) V_{CTRL} needed when $V_{IN} < 5V$.

Typical Fixed Regulator

ABSOLUTE MAXIMUM RATINGS

Power Dissipation Internally Limited
 Storage Temperature Range -65°C to +150°C
 Operating Junction Temperature Range
 SPX1582 Control Section 0°C to +125°C
 SPX1582 Power Transistor 0°C to +150°C
 Input Supply Voltage 6V

V_{CTRL} Input Voltage 13V

ELECTRICAL CHARACTERISTICS

Electrical characteristics at $V_{OUT} = V_{SENSE}$, $V_{ADJ} = 0V$, $T_A = 25^\circ C$, $C_{CTL} = C_{PWR} = C_{OUT} = 33\mu F$ tantalum cap unless otherwise specified. The \blacklozenge denotes the specifications which apply over full temperature range $-40^\circ C$ to $+85^\circ C$, unless otherwise specified.

PARAMETER	MIN	TYP	MAX	UNITS	CONDITIONS
2.5V Version					
Output Voltage	2.450 2.400	2.5	2.550 2.600	V	$V_{CTRL} = 6.0V$ to $12V$, $V_{IN} = 3.0V$ to $5.0V$, $I_O = 10mA$ \blacklozenge $I_O = 10mA$ to $3A$
2.8V Version					
Output Voltage	2.744 2.688	2.8	2.856 2.912	V	$V_{CTRL} = 6.3V$ to $12V$, $V_{IN} = 3.3V + 0.8V$, $I_O = 10mA$ \blacklozenge $I_O = 10mA$ to $3A$
3.3V Version					
Output Voltage	3.234 3.168	3.3	3.366 3.432	V	$V_{CTRL} = 6.3V$ to $12V$, $V_{IN} = 3.3V + 0.8V$, $I_O = 10mA$ \blacklozenge $I_O = 10mA$ to $3A$
All Voltage Options					
Reference Voltage	1.238	1.25	1.263	V	$V_{CTRL} = 2.75V$, $V_{IN} = 2.00V$, $I_O = 10mA$ $V_{CTRL} = 2.7V$ to $12V$, $V_{IN} = 2.05V$ to $5.5V$, $I_O = 10mA$ to $7A$
Line Regulation		1.0	3.0	mV	$V_{CTRL} = 2.5V$ to $12V$, $V_{IN} = 1.75$ to $5.5V$, $I_O = 10mA$ \blacklozenge $V_{ADJ} = 0V$
Load Regulation (Note 1) 0V		1.0	5.0	mV	\blacklozenge $V_{CTRL} = 2.75V$, $V_{IN} = V_{OUT} + 1.5V$, $I_O = 10mA$ to $3A$, $V_{ADJ} = 0V$
Dropout Voltage Min. V_{CTRL} (Note 2) ($V_{IN} - V_{OUT}$)		1.05	1.18	V	$V_{ADJ} = 0V$ $V_{IN} = 2.05V$, $I_O = 1A$
Dropout Voltage Min. V_{IN} (Note 2) ($V_{IN} - V_{OUT}$)		0.40	0.50	V	$V_{ADJ} = 0V$ $V_{IN} = 2.75V$, $I_O = 3A$
Current Limit	3.1			A	$V_{CTRL} = 2.75V$, $V_{IN} = 2.05V$, $\Delta V_{OUT} = 100mV$, $V_{ADJ} = 0V$
Minimum Load Current		5	10	mA	\blacklozenge $V_{CTRL} = 5V$, $V_{IN} = 3.3V$, $V_{ADJ} = 0V$
Thermal Regulation		0.002	0.02	%/W	30ms Pulse
Ripple Rejection	60	80		dB	$V_{CTRL} = 3.75V$, $V_{IN} = 3.75V$, $I_O = 2.3A$, $V_{ADJ} = 0V$ $T_J = 25$, $V_{RIPPLE} = 1V_{pp}$ at 120Hz
Control Pin Current		60	120	mA	\blacklozenge $V_{ADJ} = 0V$ $V_{CTRL} = 2.75V$, $V_{IN} = 2.05V$, $I_O = 3A$
Adjustble Pin Current		50	120	μA	$V_{CTRL} = 2.75V$, $V_{IN} = 2.05V$, $V_{ADJ} = 0V$, $I_O = 10mA$ \blacklozenge
Thermal Resistance TO-220-5			3	$^\circ C/W$	Junction to Case (θ_{JC})
			29.3	$^\circ C/W$	Junction to Ambient (θ_{JA})
Thermal Resistance TO-263-5			3	$^\circ C/W$	Junction to Case (θ_{JC})
			31.2	$^\circ C/W$	Junction to Ambient (θ_{JA})

Note 1: Low duty cycle pulse testing with Kelvin connections is required in order to maintain accurate data.

Note 2: Dropout voltage is defined as the minimum differential between V_{IN} and V_{OUT} or V_{CTRL} and V_{OUT} required to maintain regulation at V_{OUT} 95% Nominal V_{OUT} .

Note 3: V_{REF} is measured across Adjust pin to Sense pin.

PIN NUMBER	PIN NAME	DESCRIPTION
1	SENSE	Allows Kelvin sense of V_{OUT} at the load. (Positive side of the reference voltage of the device).
2	ADJ	Negative side of the reference voltage for the device. Adding a small bypass capacitor from the ADJ pin to ground will improve the transient response.
3	V_{OUT}	Power output of the device.
4	V_{CTRL}	Supply pin for the control circuitry of the device. The current flow into this pin will be about 1% of the output current. V_{CTRL} must be between 1.0V and 1.3V greater than the output voltage for the device to regulate.
5	V_{IN}	Output load current is supplied through this pin. V_{IN} must be between 0.1V and 0.8V greater than the output voltage for this device to regulate.

Note that TAB is internally connected to Pin 3.

FUNCTIONAL DIAGRAM

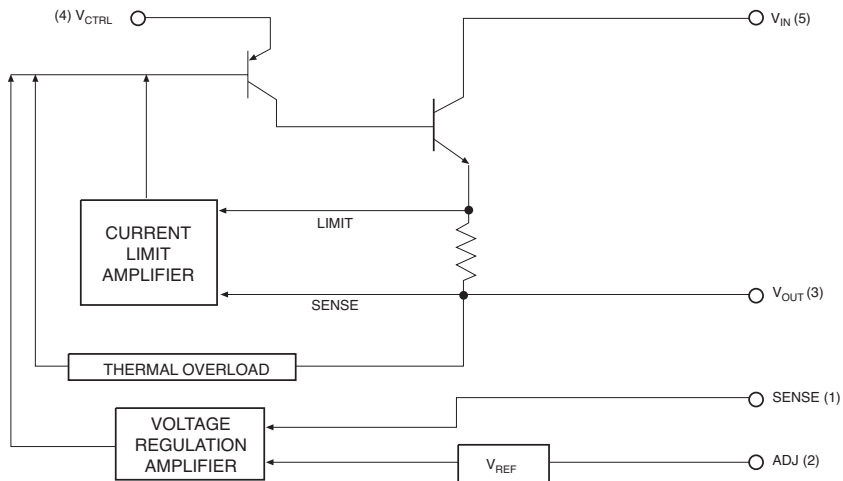

The SPX1582 is designed as a high performance and low cost solution for applications requiring a lower dropout than traditional NPN regulators.

The SPX1582 uses a separate input voltage V_{CTRL} ($V_{CTRL} \geq V_{OUT} + 1.3V$) to minimize the dropout voltage. This allows the 2.5V power for the load to come from a 3.3V system supply. As an added benefit this will reduce the heat dissipation*, and lower heatsink and cooling fan costs.

The SPX1582 can power the 2.5V core voltage for microprocessors such as a PentiumPC™, P55C™, AMD5k86™ and K6™ and the IBM PowerPC™ 603EV and 604EV processors.

A typical application would use 3.3V for V_{IN} and 5.0V for V_{CTRL} from a motherboard power supply to provide a nominal 2.5V output. Using the sense pin provides a Kelvin measurement of output for reducing resistance-associated errors.

Power Up Sequencing

The SPX1582 requires a power up sequence in that V_{IN} must be applied before V_{CTRL} to prevent a latchup condition. If this is not possible, then a 10Ω series resistor should be added to the V_{CTRL} input to prevent the device from entering into latchup if V_{CTRL} is applied before V_{IN} .

Adjustable Regulator Design

1.25V reference voltage is being developed between the SENSE pin and the ADJ pin of the SPX1582. Adding two external resistors (see fig 1.) will allow setting the output voltage from 1.25V to 6V. R_1 is chosen so that this current is specified at a minimum load current of 10mA. R_2 is given by the formula:

$$V_{OUT} = V_{REF} (1 + R_2/R_1) + I_{ADJ} (R_2).$$

The current flowing from the ADJ pin is typically 50μA. This ADJ pin contributes to the final V_{OUT} but is usually neglected. Connecting the sense pin to the top of the resistor divider will improve load regulation.

Lowering Noise

For the fixed voltage device, adding a capacitor at the GND pin will improve transient response. This capacitor is chosen in the range of 1μF to 0.1μF and will depend on the amount of output capacitance in the system.

Controlling Dimension is Inches

POS	INCHES		MILLIMETERS	
	MIN	MAX	MIN	MAX
A	.160	.190	4.06	4.83
b	.025	.040	0.63	1.04
C1	.014	.022	0.36	0.56
D	.560	.590	14.22	14.99
E	.385	.415	9.78	10.54
e	.062	.072	1.57	1.83
e1	.263	.273	6.68	6.93
e3	.050	.040	0.76	1.02
F	.045	.055	1.14	1.40
H1	.234	.258	5.94	6.55
J1	.090	.115	2.29	2.92
ϕ P	.146	.156	3.71	3.96
Q	.103	.113	2.62	2.87
L	.540	.560	13.72	14.22
α	$\frac{3}{7}$	$\frac{7}{7}$	$\frac{3}{7}$	$\frac{7}{7}$
U	.30 REF		7.62 REF	
V	.24 REF		6.10 REF	

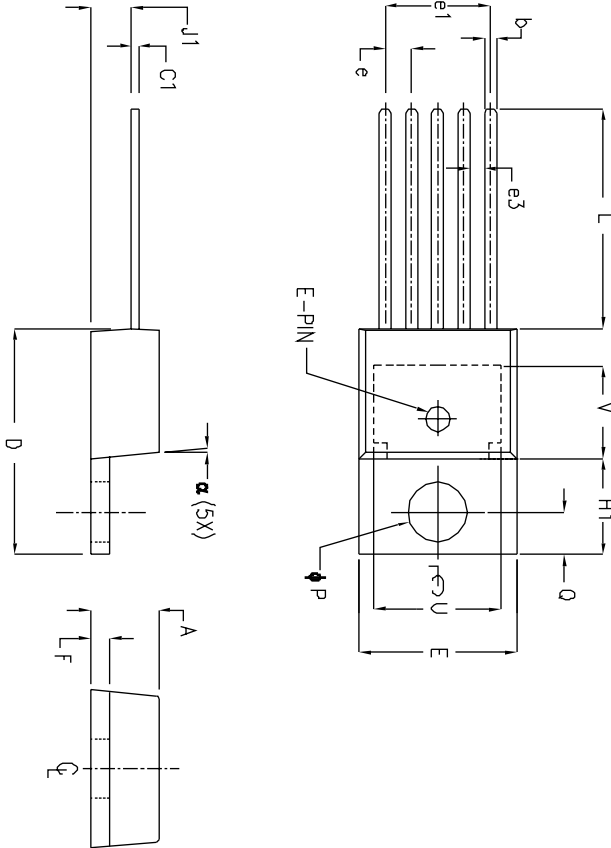

NOTE:
 1. DIMENSION C1 APPLY FOR TIN PLATE FINISH.
 2. FOR SOLDER DIP LEAD FINISH, DIMENSION C1 SHOULD BE .015"-.027"(.38-.69MM).
 3. J1 DIMENSION TO BE COVERED BY FINAL VISUAL OUTGOING SPEC, CSM-220-017 (i.e. Y-AXIS BEND LEAD ALLOWED FOR 1 LEAD THICKNESS.

TO220 5L PKG OUTLINE

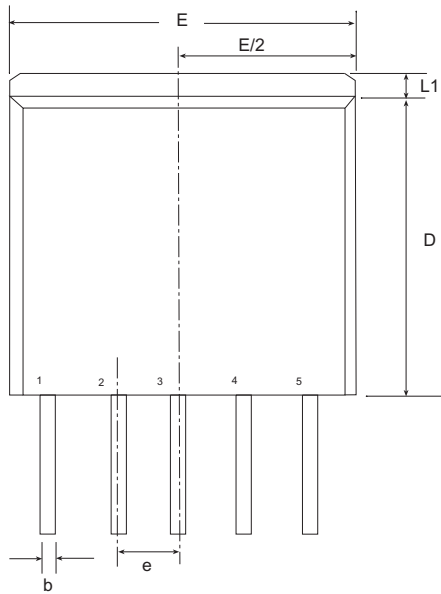

FRONT VIEW

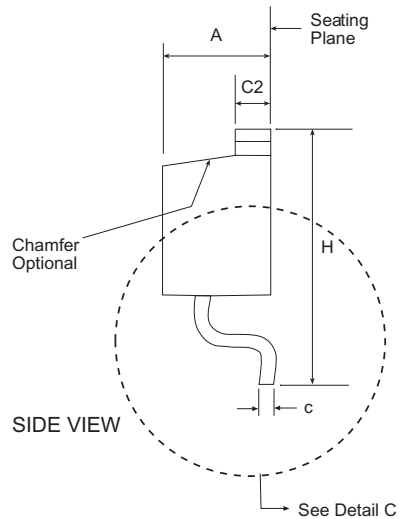

SIDE VIEW

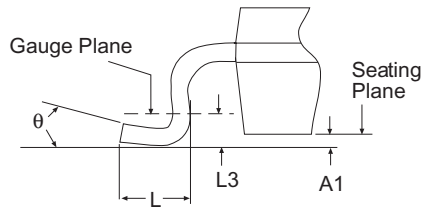

DETAIL C

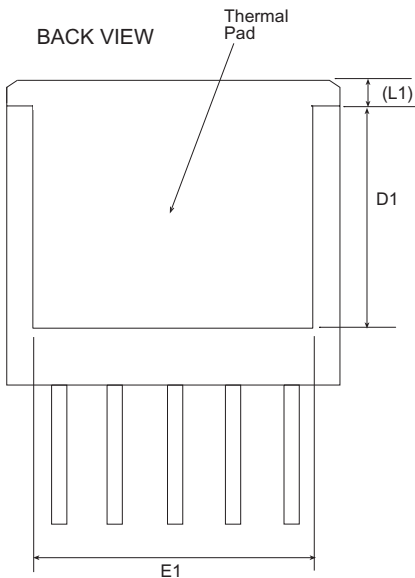

BACK VIEW

5 Pin TO-263 JEDEC TO-263 Variation BA						
SYMBOL	Dimensions in Inches: Controlling Dimension			Dimensions in Millimeters Conversion Factor: 1 Inch = 25.40 mm		
	MIN	NOM	MAX	MIN	NOM	MAX
A	0.160	-	0.190	4.06	-	4.83
A1	0.000	-	0.010	0.00	-	0.25
b	0.020	-	0.039	0.51	-	0.99
c	0.015	-	0.029	0.38	-	0.74
c2	0.045	-	0.065	1.14	-	1.65
D	0.330	-	0.380	8.38	-	9.65
D1	0.270	-	-	6.86	-	-
E	0.380	-	0.420	9.65	-	10.67
E1	0.245	-	-	6.22	-	-
e	.067 BSC			1.702 BSC		
H	0.575	-	0.625	14.61	-	15.88
L	0.070	-	0.110	1.78	-	2.79
L1	-	-	0.066	-	-	1.68
L3	.010 BSC			0.254 BSC		
θ	0°	-	8°	0°	-	8°
SIPEX Pkg Signoff Date/Rev:				JL Jun12-06 / Rev B		

Part Number	Accuracy	Output Voltage	Packages
SPX1582U5	2.0%	Adj	5-Pin TO-220
SPX1582U5-2-5	2.0%	2.5V	5-Pin TO-220
SPX1582U5-2-8	2.0%	2.8V	5-Pin TO-220
SPX1582U5-3-3	2.0%	3.3V	5-Pin TO-220
SPX1582T5	2.0%	Adj	5-Pin TO-263
SPX1582T5/TR	2.0%	Adj	5-Pin TO-263
SPX1582T5-1-5	2.0%	2.5V	5-Pin TO-263
SPX1582T5-1-5/TR.....	2.0%	2.5V	5-Pin TO-263
SPX1582T5-1-8	2.0%	2.5V	5-Pin TO-263
SPX1582T5-1-8/TR.....	2.0%	2.5V	5-Pin TO-263
SPX1582T5-2-5	2.0%	2.5V	5-Pin TO-263
SPX1582T5-2-5/TR.....	2.0%	2.5V	5-Pin TO-263
SPX1582T5-2-8	2.0%	2.8V	5-Pin TO-263
SPX1582T5-2-8/TR.....	2.0%	2.8V	5-Pin TO-263
SPX1582T5-3-3	2.0%	3.3V	5-Pin TO-263
SPX1582T5-3-3/TR.....	2.0%	3.3V	5-Pin TO-263

Available in lead free packaging. To order add "-L" suffix to part number.
 Example: SPX1582T5-3-3/TR = standard; SPX1582T5-L-3-3/TR = lead free.

/TR = Tape and Reel

Pack quantity is 500 for TO-263.



Sipex Corporation

**Headquarters and
 Sales Office**
 233 South Hillview Drive
 Milpitas, CA 95035
 TEL: (408) 934-7500
 FAX: (408) 935-7600

Sipex Corporation reserves the right to make changes to any products described herein. Sipex does not assume any liability arising out of the application or use of any product or circuit described herein; neither does it convey any license under its patent rights nor the rights of others.

X-ON Electronics

Largest Supplier of Electrical and Electronic Components

Click to view similar products for [LDO Voltage Regulators](#) category:

Click to view products by [MaxLinear](#) manufacturer:

Other Similar products are found below :

[AP7363-SP-13](#) [L79M05TL-E](#) [PT7M8202B12TA5EX](#) [TCR3DF185,LM\(CT](#) [MP2013GQ-33-Z](#) [059985X](#) [NCP4687DH15T1G](#) [701326R](#)
[TCR2EN28,LF\(S](#) [NCV8170AXV250T2G](#) [TCR2EN18,LF\(S](#) [AP7315-25W5-7](#) [IFX30081LDVGRNXUMA1](#) [NCV47411PAAJR2G](#)
[AP2113KTR-G1](#) [AP2111H-1.2TRG1](#) [ZLDO1117QK50TC](#) [AZ1117IH-1.8TRG1](#) [TCR3DG12,LF](#) [MIC5514-3.3YMT-T5](#) [MIC5512-1.2YMT-](#)
[T5](#) [MIC5317-2.8YM5-T5](#) [SCD7912BTG](#) [NCP154MX180270TAG](#) [SCD33269T-5.0G](#) [NCV8170BMX330TCG](#) [NCV8170AMX120TCG](#)
[NCP706ABMX300TAG](#) [NCP153MX330180TCG](#) [NCP114BMX075TCG](#) [MC33269T-3.5G](#) [CAT6243-ADJCMT5T](#) [TCR3DG33,LF](#)
[AP2127N-1.0TRG1](#) [TCR4DG35,LF](#) [LT1117CST-3.3](#) [LT1117CST-5](#) [TAR5S15U\(TE85L,F\)](#) [TAR5S18U\(TE85L,F\)](#) [TCR3UG19A,LF](#)
[TCR4DG105,LF](#) [NCV8170AMX360TCG](#) [MIC94310-NYMT-T5](#) [NCV8186BMN175TAG](#) [NCP715SQ15T2G](#) [MIC5317-3.0YD5-T5](#)
[NCV563SQ18T1G](#) [MIC5317-2.8YD5-T5](#) [NCP715MX30TBG](#) [MIC5317-2.5YD5-T5](#)