

GENERAL DESCRIPTION

The SPX1587 is a low power positive-voltage regulator designed to satisfy moderate power requirements with a cost effective, small footprint solution.

This device is an excellent choice for use in battery-powered applications and portable computers. The SPX1587 features very low quiescent current and a low dropout voltage of 1.1V at a full load. As output current decreases, quiescent current flows into the load, increasing efficiency. SPX1587 is available in adjustable or fixed 1.5V, 2.5V, 3.3V and 5.0V output voltages.

The SPX1587 is offered in several 3-pin surface mount packages: TO-252, TO-220 and TO-263. An output capacitor of 10µF ceramic or tantalum provides unconditional stability.

APPLICATIONS

- Desktop PC's Servers
- Powering VGA and Sound Cards
- Adjustable Power Supplies
- Portable Instrumentation

FEATURES

- Guaranteed 3A Output Current
- Three Terminal Adjustable or Fixed 1.5V, 2.5V, 3.3V and 5.0V
- Low Quiescent Current
- Low Dropout Voltage: 1.1V at 3A
- Line Regulation: 0.1%
- Load Regulation: 0.1%
- Stable with 10uF Ceramic Capacitor
- Over Current and Thermal Protection
- Similar to Industry Standard LT1085/LT1585
- RoHS Compliant Lead Free 3-Pin TO-220, TO-252 and TO-263 Packages

FUNCTIONAL DIAGRAM

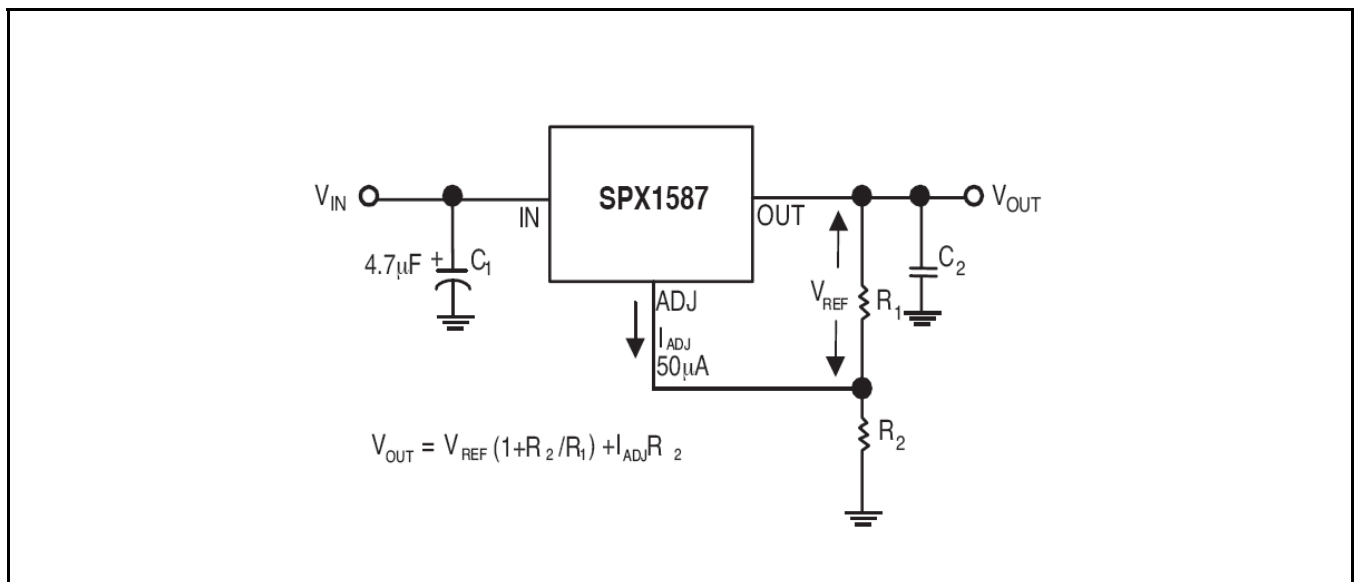

Fig. 1: SPX1587 Functional Diagram (Adjustable version)



ABSOLUTE MAXIMUM RATINGS

These are stress ratings only and functional operation of the device at these ratings or any other above those indicated in the operation sections of the specifications below is not implied. Exposure to absolute maximum rating conditions for extended periods of time may affect reliability.

Input Supply Voltage V_{IN} +10.0V
 Input to Output Voltage +8.8V
 Storage Temperature -65°C to 150°C
 Power Dissipation Internally Limited
 Lead Temperature (Soldering, 5 sec) 260°C
 ESD Rating (HBM - Human Body Model) 2kV

OPERATING RATINGS

Junction Temperature Range -40°C to 125°C
 Thermal Resistance
 TO-220 θ_{JC} 3°C/W
 TO-220 θ_{JA} 29.4°C/W
 TO-263 θ_{JC} 3°C/W
 TO-263 θ_{JA} 31.4°C/W
 TO-252 θ_{JC} 6°C/W
 TO-252 θ_{JA} 50°C/W

ELECTRICAL SPECIFICATIONS

Specifications with standard type are for an Operating Ambient Temperature of $T_A = 25^\circ\text{C}$ only; limits applying over the full Operating Temperature range (-40°C to +85°C) are denoted by a “•”. Minimum and Maximum limits are guaranteed through test, design, or statistical correlation. Typical values represent the most likely parametric norm at $T_A = 25^\circ\text{C}$, and are provided for reference purposes only. Unless otherwise indicated, $V_{IN} = V_{OUT} + 1.5\text{V}$, $T_A = 25^\circ\text{C}$, $C_{IN} = C_{OUT} = 10\mu\text{F}$, $I_{OUT} = 10\text{mA}$.

Parameter	Min.	Typ.	Max.	Units	Conditions
1.5V Version					
Output Voltage SPX1587A	1.485	1.500	1.515	V	$I_{OUT} = 10\text{mA}$, $V_{OUT} = 3.5\text{V}$
	1.470		1.530		• $10\text{mA} \leq I_{OUT} \leq 3\text{A}$, $3.0\text{V} \leq V_{OUT} \leq 10\text{V}$
2.5V Version					
Output Voltage SPX1587	2.450	2.500	2.550	V	$I_{OUT} = 10\text{mA}$, $V_{OUT} = 4.5\text{V}$
	2.425		2.575		• $10\text{mA} \leq I_{OUT} \leq 3\text{A}$, $4.25\text{V} \leq I_{OUT} \leq 10\text{V}$
3.3V Version					
Output Voltage SPX1587A	3.267	3.300	3.333	V	$I_{OUT} = 10\text{mA}$, $V_{OUT} = 5\text{V}$
	3.234		3.366		• $10\text{mA} \leq I_{OUT} \leq 3\text{A}$, $4.75\text{V} \leq V_{OUT} \leq 10\text{V}$
Output Voltage SPX1587	3.234	3.300	3.366	V	$I_{OUT} = 10\text{mA}$, $V_{OUT} = 5\text{V}$
	3.201		3.399		• $10\text{mA} \leq I_{OUT} \leq 3\text{A}$, $4.75\text{V} \leq V_{OUT} \leq 10\text{V}$
5.0V Version					
Output Voltage SPX1587A	4.950	5.000	5.050	V	$I_{OUT} = 10\text{mA}$, $V_{OUT} = 7\text{V}$
	4.900		5.100		• $10\text{mA} \leq I_{OUT} \leq 3\text{A}$, $6.50\text{V} \leq V_{OUT} \leq 10\text{V}$
All Voltage Options					
Reference Voltage SPX1587A	1.238	1.250	1.262	V	$I_{OUT} = 10\text{mA}$, $V_{IN} - V_{OUT} = 2\text{V}$
	1.225		1.275		• $10\text{mA} \leq I_{OUT} \leq 3\text{A}$, $1.50\text{V} \leq V_{IN} - V_{OUT} \leq 10\text{V}$
Reference Voltage SPX1587	1.225	1.250	1.275	V	$I_{OUT} = 10\text{mA}$, $V_{IN} - V_{OUT} = 2\text{V}$
	1.212		1.287		• $10\text{mA} \leq I_{OUT} \leq 3\text{A}$, $1.50\text{V} \leq V_{IN} - V_{OUT} \leq 10\text{V}$
Output Voltage Temperature Stability - SPX1587A		0.3		%	
Output Voltage Temperature Stability - SPX1587		0.5		%	
Line Regulation		0.1	0.2	%	$3.0\text{V} \leq V_{IN} \leq 10\text{V}$, $V_{OUT} = 1.5\text{V}$
					$4.25\text{V} \leq V_{IN} \leq 10\text{V}$, $V_{OUT} = 2.5\text{V}$
					$4.75\text{V} \leq V_{IN} \leq 10\text{V}$, $V_{OUT} = 3.3\text{V}$
					$6.50\text{V} \leq V_{IN} \leq 10\text{V}$, $V_{OUT} = 5.0\text{V}$
Load Regulation		0.1	0.3	%	$10\text{mA} \leq I_{OUT} \leq 3\text{A}$, $V_{OUT} = 1.5\text{V}$
					$10\text{mA} \leq I_{OUT} \leq 3\text{A}$, $V_{OUT} = 2.5\text{V}$
					$10\text{mA} \leq I_{OUT} \leq 3\text{A}$, $V_{OUT} = 3.3\text{V}$
					$10\text{mA} \leq I_{OUT} \leq 3\text{A}$, $V_{OUT} = 5.0\text{V}$

Parameter	Min.	Typ.	Max.	Units	Conditions
Dropout Voltage (note 2)		1.00		V	$I_{OUT}=1A$
		1.05			$I_{OUT}=2A$
		1.10	1.2		$I_{OUT}=3A$
Minimum Load Current (note 4)		4	10	mA	
Quiescent Current		4	10	mA	Fixed Voltage Versions
Adjust Pin Current		50		μA	
			120	μA	•
Current Limit	3.2	5		A	$V_{IN}-V_{OUT}=2V$
Thermal Regulation		0.01	0.1	%/W	25°C, 30ms pulse
Ripple Rejection	60	75		dB	$F_{RIPPLE}=120Hz, V_{IN}-V_{OUT}=2V, V_{RIPPLE}=1V_{PP}$
Long Term Stability		0.03		%	125°C, 1000 hours
RMS Output Noise		0.03		%	% of V_{OUT} , $10Hz \leq f \leq 10kHz$

Note 1: Output temperature coefficient is defined as the worst case voltage change divided by the total temperature range
 Note 2: Dropout voltage is defined as the input to output differential at which the output voltage drops 100mV below its nominal value measured at 1V differential at very low values of programmed output voltage, the minimum input supply voltage of 2V (2.3V over temperature) must be taken into account.
 Note 3: Thermal regulation is defined as the change in output voltage at a time T after a change in power dissipation is applied. Excluding load or line regulation effect.
 Note 4: Adjustable Version Only.

BLOCK DIAGRAM

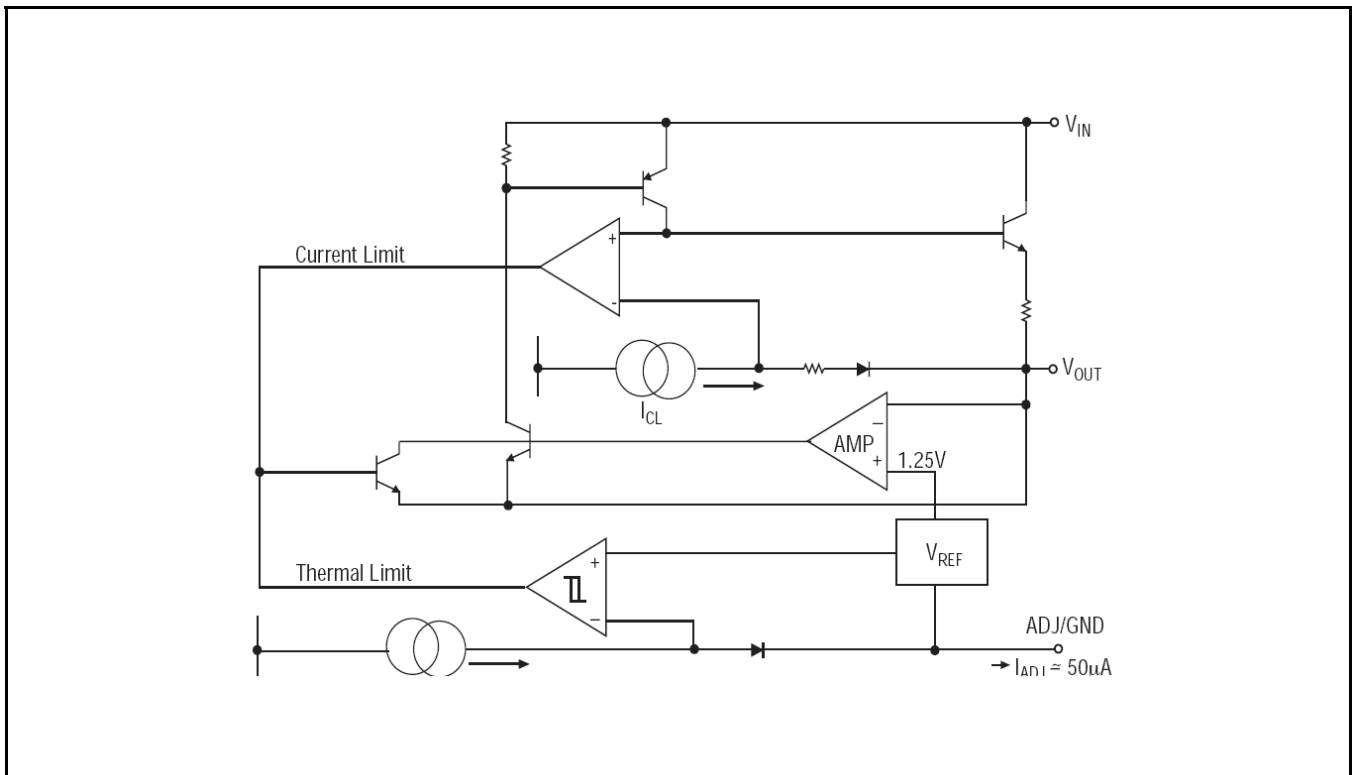

Fig. 2: SPX1587 Block Diagram

PIN ASSIGNMENT

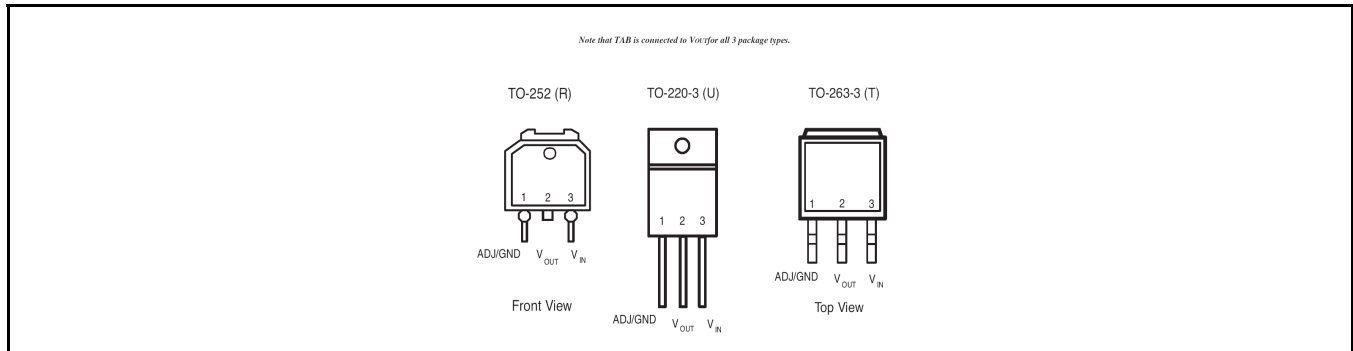

Fig. 3: SPX1587 Pin Assignment

PIN DESCRIPTION

Name	Pin Number	Description
ADJ/GND	1	Adjustable Voltage Pin or Ground signal for fixed voltage versions.
V _{OUT}	2	Output Voltage
V _{IN}	3	Input Voltage
TAB	TAB	Tab is connected to V _{OUT} (pin 2) for all packages

ORDERING INFORMATION

Part Number	Junction Temperature Range	Marking	Package	Packing Quantity	Note 1
SPX1587T-L	-40°C ≤ T _J ≤ +125°C	Sipex SPX1587T YYWWLX	TO263-3	Bulk	Lead Free
SPX1587T-L/TR				500/Tape & Reel	
SPX1587T-L-1-5	-40°C ≤ T _J ≤ +125°C	Sipex SPX1587T 15YYWWLX	TO263-3	Bulk	Lead Free
SPX1587T-L-1-5/TR				500/Tape & Reel	
SPX1587T-L-5-0	-40°C ≤ T _J ≤ +125°C	Sipex SPX1587T 50YYWWLX	TO263-3	Bulk	Lead Free
SPX1587T-L-5-0/TR				500/Tape & Reel	
SPX1587U-L-3-3	-40°C ≤ T _J ≤ +125°C	Sipex SPX1587U 33YYWWLX	TO220-3	Bulk	Lead Free
SPX1587U-L-5-0	-40°C ≤ T _J ≤ +125°C	Sipex SPX1587U 50YYWWLX	TO220-3	Bulk	Lead Free
SPX1587AR-L	-40°C ≤ T _J ≤ +125°C	Sipex SPX1587AR YYWWLX	TO252-3	Bulk	Lead Free
SPX1587AR-L/TR				2K/Tape & Reel	
SPX1587AT-L	-40°C ≤ T _J ≤ +125°C	Sipex SPX1587AT YYWWLX	TO263-3	Bulk	Lead Free
SPX1587AT-L/TR				500/Tape & Reel	
SPX1587AT-L-2-5	-40°C ≤ T _J ≤ +125°C	Sipex SPX1587AT 25YYWWLX	TO263-3	Bulk	Lead Free
SPX1587AT-L-2-5/TR				500/Tape & Reel	
SPX1587AT-L-3-3	-40°C ≤ T _J ≤ +125°C	Sipex SPX1587AT 33YYWWLX	TO263-3	Bulk	Lead Free
SPX1587AT-L-3-3/TR				500/Tape & Reel	
SPX1587AU-L	-40°C ≤ T _J ≤ +125°C	Sipex SPX1587AU YYWWLX	TO220-3	Bulk	Lead Free

“YY” = Year – “WW” = Work Week – “L” = Lead Free Indicator – “X” = Lot Number; when applicable.

TYPICAL PERFORMANCE CHARACTERISTICS

All data taken at $V_{IN} = V_{OUT} + 1.5V$, $T_A = 25^\circ C$, $C_{IN} = C_{OUT} = 10\mu F$, $I_{OUT} = 10mA$ unless otherwise specified - Schematic and BOM from Application Information section of this datasheet.

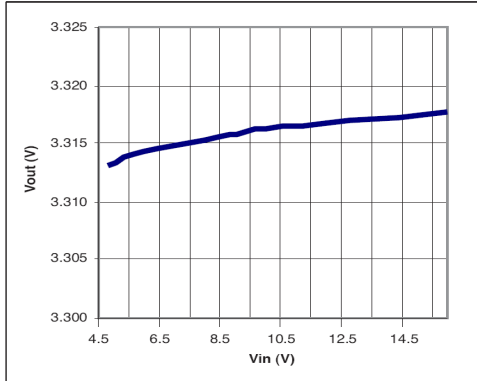

Fig. 4: Line Regulation for SPX1587U-3-3
 $I_{OUT} = 10mA$

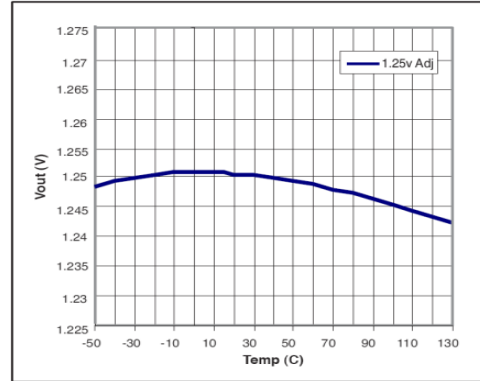

Fig. 5: V_{OUT} versus Temperature
 $V_{IN} = 2.5V$, $I_{OUT} = 10mA$

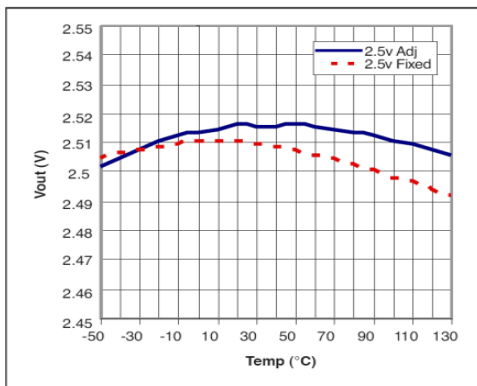

Fig. 6: V_{OUT} versus Temperature
 $V_{IN} = 4.0V$, $I_{OUT} = 10mA$

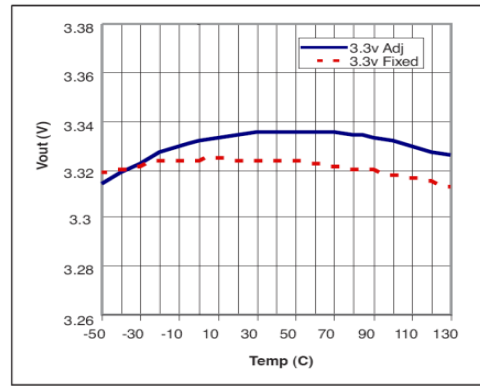

Fig. 7: V_{OUT} versus Temperature
 $V_{IN} = 5.0V$, $I_{OUT} = 10mA$

APPLICATION INFORMATION

OUTPUT CAPACITOR

To ensure the stability of the SPX1587, an output capacitor of at least $10\mu F$ (ceramic or tantalum) or $22\mu F$ (aluminum) is required. The value may change based on the application requirements of the output load or temperature range. The value of ESR can vary based on the type of capacitor used in the applications to guarantee stability. The recommended value for ESR is 0.5Ω or less. A larger value of output capacitance (up to $100\mu F$) can improve the load transient response.

SOLDERING METHODS

The SPX1587 die is attached to the heatsink lead which exits opposite the input, output, and ground pins.

THERMAL CHARACTERISTICS

The SPX1587 features the internal thermal limiting to protect the device during overload conditions. Special care needs to be taken during continuous load conditions such that the maximum junction temperature does not exceed $125^\circ C$. Thermal protection is activated at $>179^\circ C$ and deactivated at $<165^\circ C$.

The thermal interaction from other components in the application can affect the

thermal resistance of the SPX1587. The actual thermal resistance can be determined with experimentation.

The SPX1587 power dissipation is calculated as follows:

$$P_D = (V_{IN} - V_{OUT}) \times I_{OUT}$$

Maximum Junction Temperature range:

$$T_J = T_{A(MAX)} + P_D \times \theta_{JA}$$

Where θ_{JA} is the junction-to-ambient thermal resistance of the package.

Maximum junction temperature must not exceed 125°C.

RIPPLE REJECTION

Ripple rejection can be improved by adding a capacitor between the ADJ pin and ground as shown in Figure 11. When ADJ pin bypassing is used, the value of the output capacitor required increases to its maximum. If the ADJ pin is not bypassed, the value of the output capacitor can be lowered to 22µF for an electrolytic aluminum capacitor or 10µF for a solid tantalum capacitor (Fig 10).

However the value of the ADJ-bypass capacitor should be chosen with respect to the following equation:

$$C = \frac{1}{6.28 \times F_R \times R_1}$$

Where

C = value of the capacitor in Farads (select an equal or larger standard value)

F_R = ripple frequency in Hz

R_1 = value of resistor R1 in Ohms.

If an ADJ-bypass capacitor is used, the amplitude of the output ripple will be independent of the output voltage. If an ADJ-bypass capacitor is not used, the output ripple will be proportional to the ratio of the output voltage to the reference voltage:

$$M = \frac{V_{OUT}}{V_{REF}}$$

Where

M = multiplier for the ripple seen when the ADJ pin is optimally bypassed.

$V_{REF} = 1.25V$

Ripple rejection for the adjustable version is showing in Figure 8.

OUTPUT VOLTAGE

The output of the adjustable regulator can be set to any voltage between 1.25V and 15V. The value of V_{OUT} can be quickly approximated using the formula

$$V_{OUT} = 1.25 \times \frac{R_1 + R_2}{R_1}$$

Small correction to this formula is required depending on the values of resistors R1 and R2, since the adjustable pin current (approx 50µA) flows through R2. When I_{ADJ} is taken into account, the formula becomes

$$V_{OUT} = V_{REF} \times \left(1 + \frac{R_2}{R_1}\right) + I_{ADJ} \times R_2$$

Where

$V_{REF} = 1.25V$

LAYOUT CONSIDERATIONS

Parasitic line resistance can degrade load regulation. In order to avoid this, connect R1 directly to V_{OUT} as illustrated in Figure 13. For the same reason, R2 should be connected to the negative side of the load.

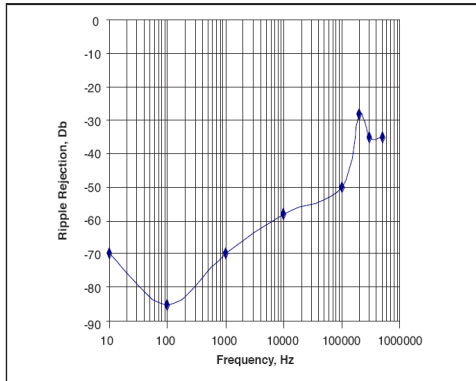

Fig. 8: Ripple Rejection
 $V_{IN}=3.3V$, $V_{OUT}=1.8V(Adj)$, $I_{LOAD}=200mA$

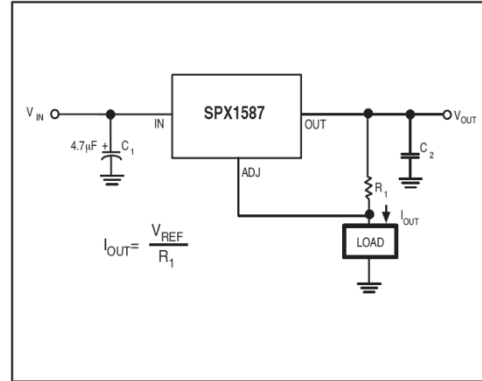

Fig. 9: Current Source

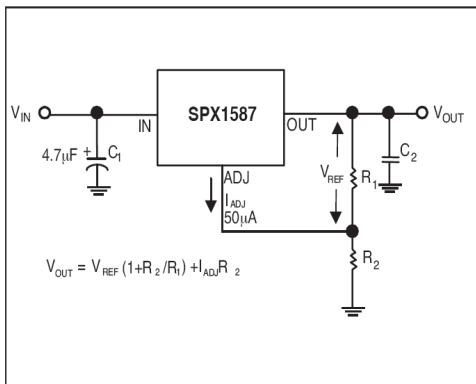

Fig. 10: Typical Adjustable Regulator

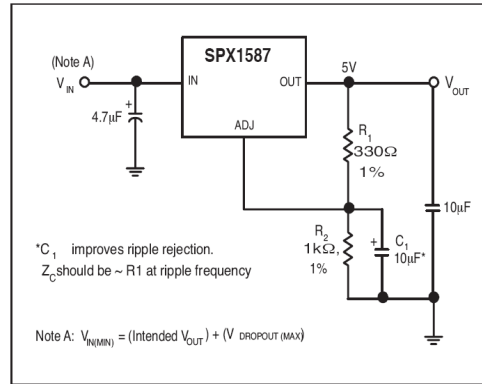

Fig. 11: Improving Ripple Rejection

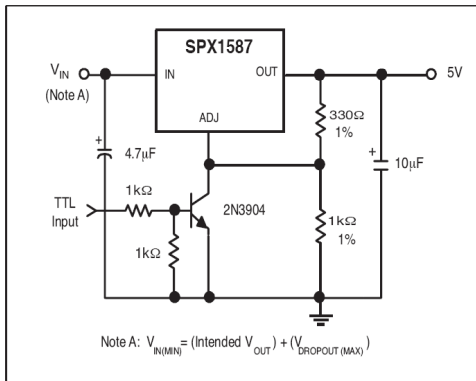

Fig. 12: 5V Regulator With Shutdown

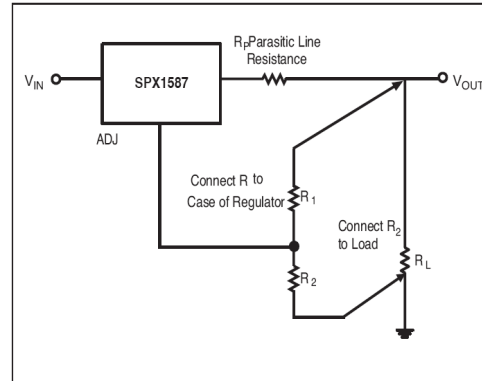
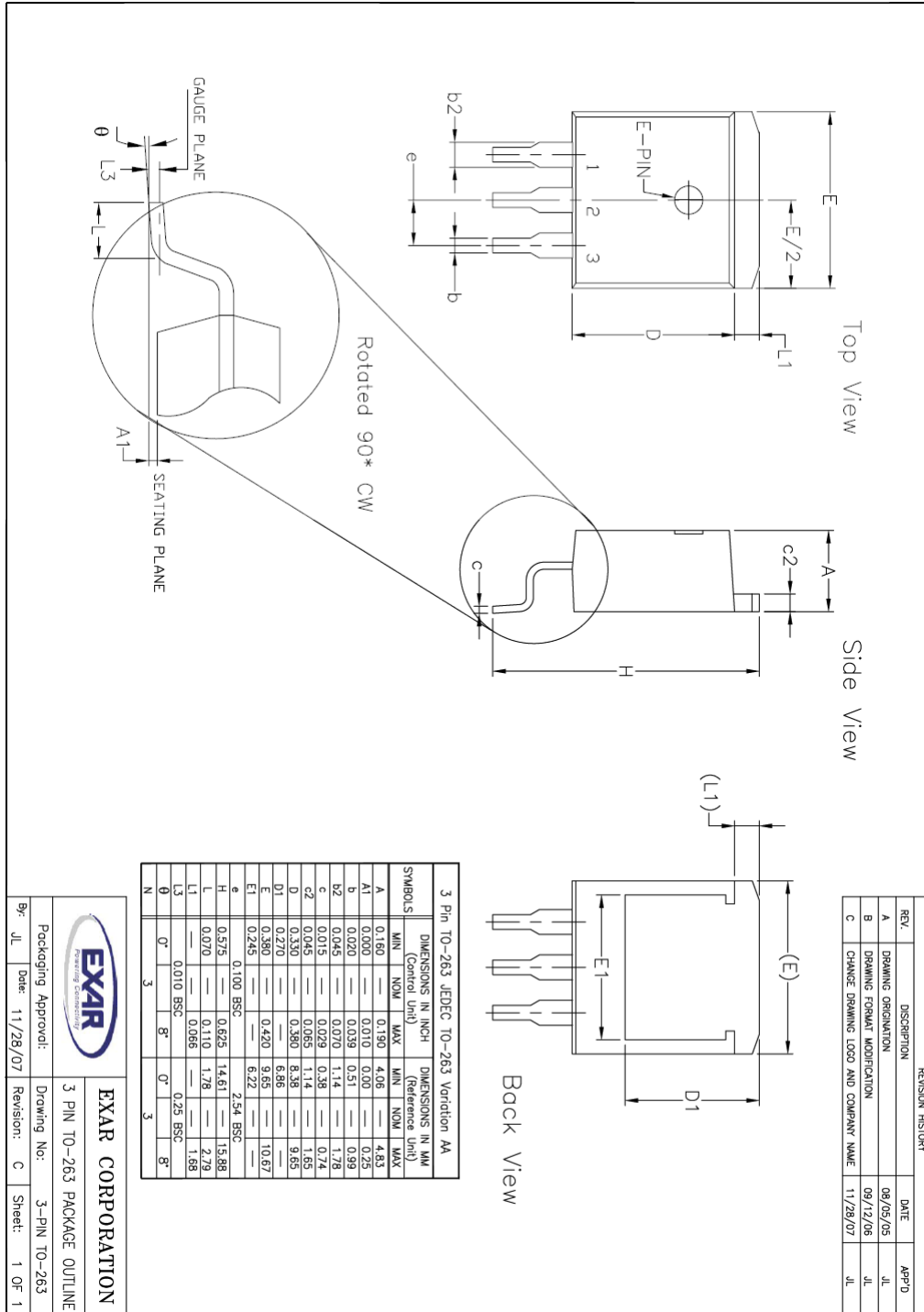

Fig. 13: Recommended Connections for Best Results

PACKAGE SPECIFICATION

3-PIN TO263



3-PIN TO220

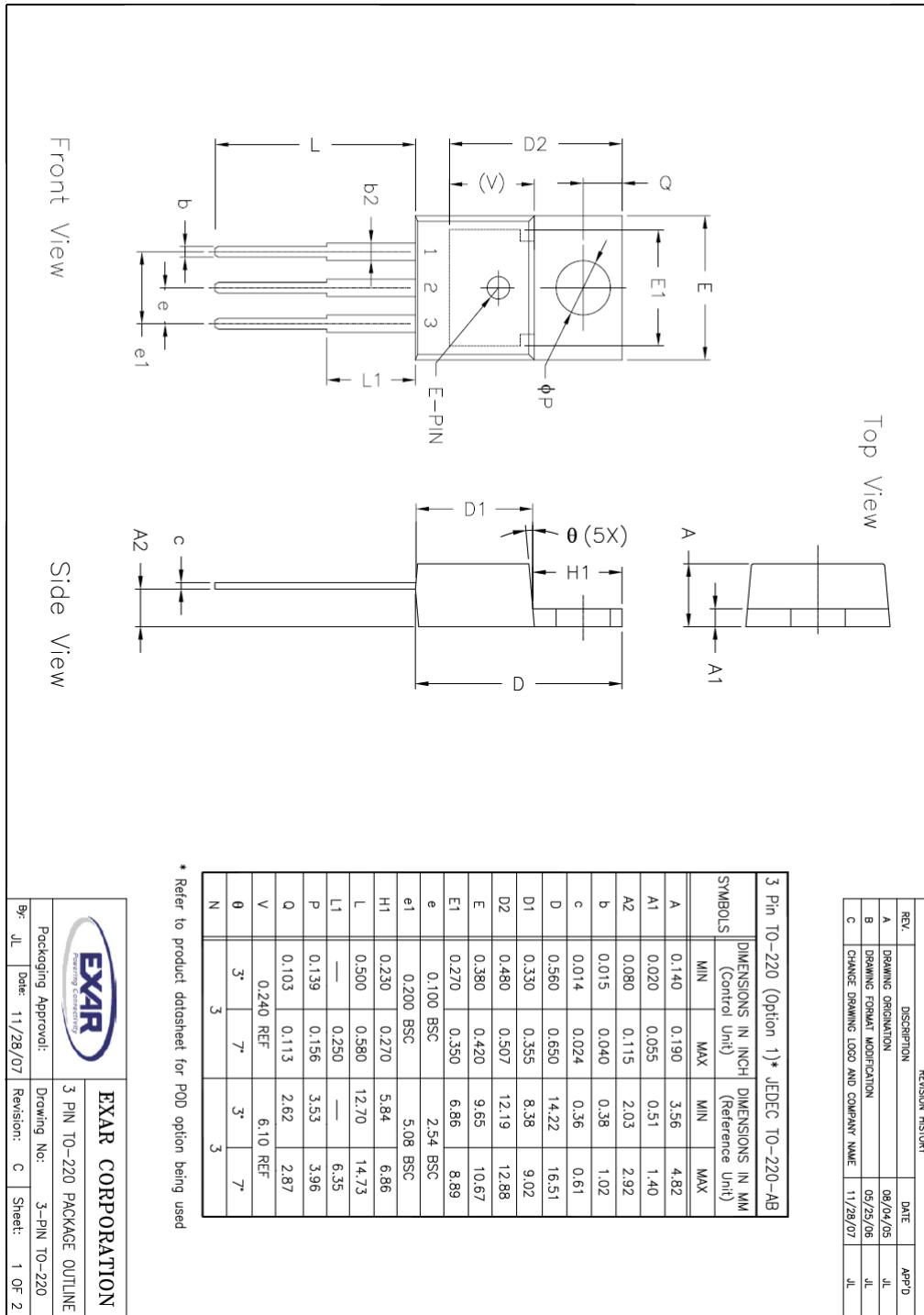

3-PIN TO252

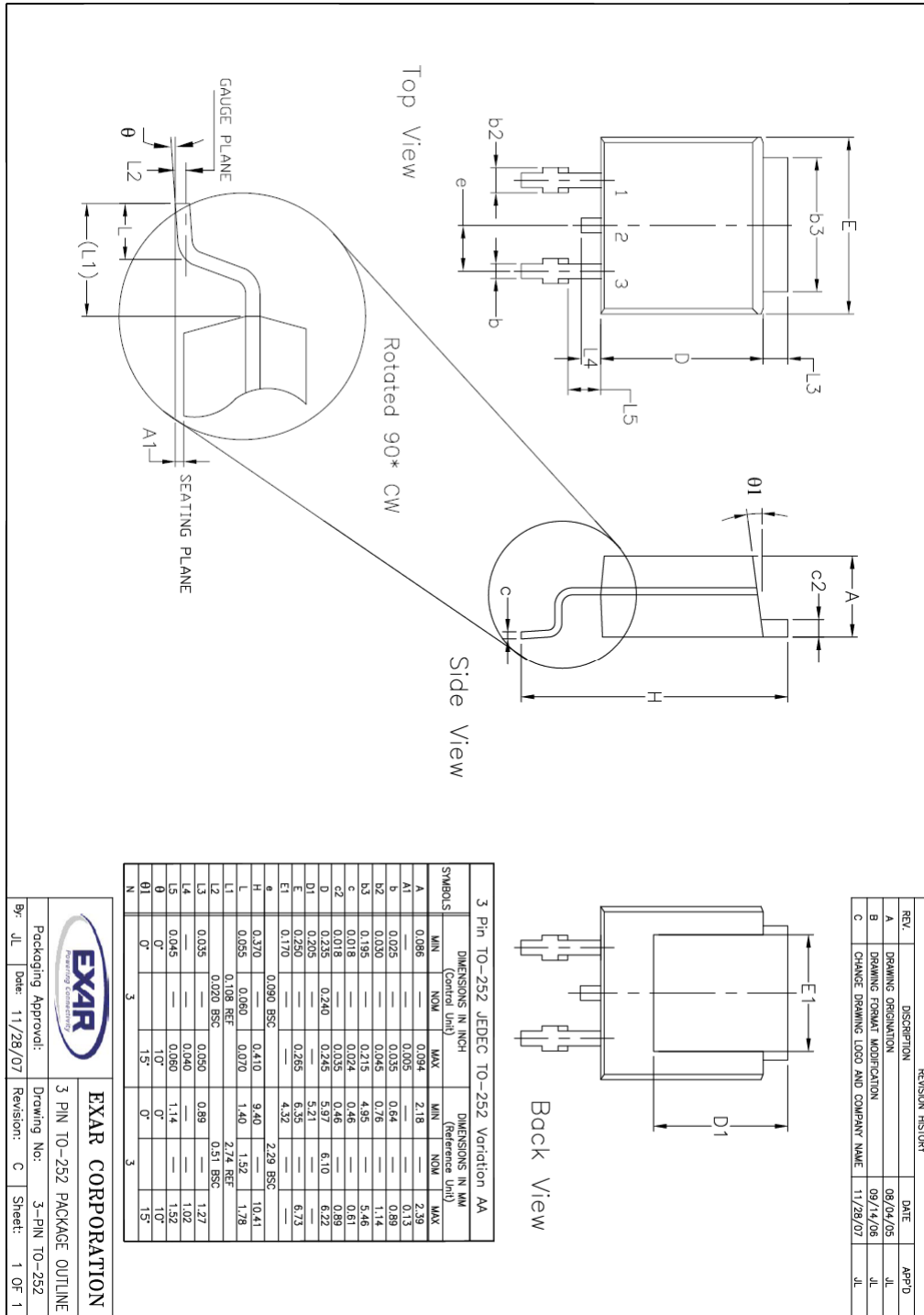

REV.	DESCRIPTION	DATE	APP'D
A	DRAWING ORIGINATOR	09/04/05	JL
B	DRAWING FORMAT MODIFICATION	09/14/06	JL
C	CHANGE DRAWING LOGO AND COMPANY NAME	11/28/07	JL

EXAR CORPORATION
 3 PIN TO-252 PACKAGE OUTLINE

Br: JL Date: 11/28/07 Revision: C Sheet: 1 OF 1



REVISION HISTORY

Revision	Date	Description
2.0.0		Reformat of datasheet Added marking information

FOR FURTHER ASSISTANCE

Email:

customersupport@exar.com

Exar Technical Documentation:

<http://www.exar.com/TechDoc/default.aspx?>

EXAR CORPORATION

HEADQUARTERS AND SALES OFFICES

48720 Kato Road

Fremont, CA 94538 – USA

Tel.: +1 (510) 668-7000

Fax: +1 (510) 668-7030

www.exar.com



NOTICE

EXAR Corporation reserves the right to make changes to the products contained in this publication in order to improve design, performance or reliability. EXAR Corporation assumes no responsibility for the use of any circuits described herein, conveys no license under any patent or other right, and makes no representation that the circuits are free of patent infringement. Charts and schedules contained here in are only for illustration purposes and may vary depending upon a user’s specific application. While the information in this publication has been carefully checked; no responsibility, however, is assumed for inaccuracies.

EXAR Corporation does not recommend the use of any of its products in life support applications where the failure or malfunction of the product can reasonably be expected to cause failure of the life support system or to significantly affect its safety or effectiveness. Products are not authorized for use in such applications unless EXAR Corporation receives, in writing, assurances to its satisfaction that: (a) the risk of injury or damage has been minimized; (b) the user assumes all such risks; (c) potential liability of EXAR Corporation is adequately protected under the circumstances.

Reproduction, in part or whole, without the prior written consent of EXAR Corporation is prohibited.

X-ON Electronics

Largest Supplier of Electrical and Electronic Components

Click to view similar products for [LDO Voltage Regulators](#) category:

Click to view products by [MaxLinear](#) manufacturer:

Other Similar products are found below :

[AP7363-SP-13](#) [L79M05TL-E](#) [PT7M8202B12TA5EX](#) [TCR3DF185,LM\(CT](#) [MP2013GQ-33-Z](#) [059985X](#) [NCP4687DH15T1G](#) [701326R](#)
[TCR2EN28,LF\(S](#) [NCV8170AXV250T2G](#) [TCR2EN18,LF\(S](#) [AP7315-25W5-7](#) [IFX30081LDVGRNXUMA1](#) [NCV47411PAAJR2G](#)
[AP2113KTR-G1](#) [AP2111H-1.2TRG1](#) [ZLDO1117QK50TC](#) [AZ1117IH-1.8TRG1](#) [TCR3DG12,LF](#) [MIC5514-3.3YMT-T5](#) [MIC5512-1.2YMT-](#)
[T5](#) [MIC5317-2.8YM5-T5](#) [SCD7912BTG](#) [NCP154MX180270TAG](#) [SCD33269T-5.0G](#) [NCV8170BMX330TCG](#) [NCV8170AMX120TCG](#)
[NCP706ABMX300TAG](#) [NCP153MX330180TCG](#) [NCP114BMX075TCG](#) [MC33269T-3.5G](#) [CAT6243-ADJCMT5T](#) [TCR3DG33,LF](#)
[AP2127N-1.0TRG1](#) [TCR4DG35,LF](#) [LT1117CST-3.3](#) [LT1117CST-5](#) [TAR5S15U\(TE85L,F\)](#) [TAR5S18U\(TE85L,F\)](#) [TCR3UG19A,LF](#)
[TCR4DG105,LF](#) [NCV8170AMX360TCG](#) [MIC94310-NYMT-T5](#) [NCV8186BMN175TAG](#) [NCP715SQ15T2G](#) [MIC5317-3.0YD5-T5](#)
[NCV563SQ18T1G](#) [MIC5317-2.8YD5-T5](#) [NCP715MX30TBG](#) [MIC5317-2.5YD5-T5](#)