

400mA Low Dropout Voltage Regulator with Shutdown

FEATURES

- Output 3.3V, 5.0V at 400mA Output
- Very Low Quiescent Current, 100 μ A
- Low Dropout Voltage, 420mV at 400mA
- Extremely Tight Load and Line Regulation
- Very Low Temperature Coefficient
- Current & Thermal Limiting
- Error Flag Warns Of Output Dropout
- Logic-Controlled Electronic Shutdown
- Output Programmable From 1.24V to 20V (for SO-8)

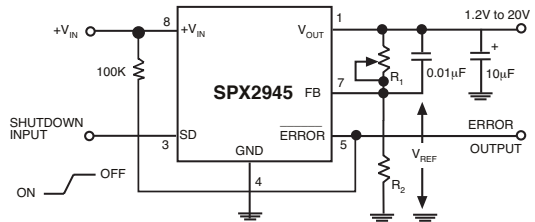

Adjustable Regulator

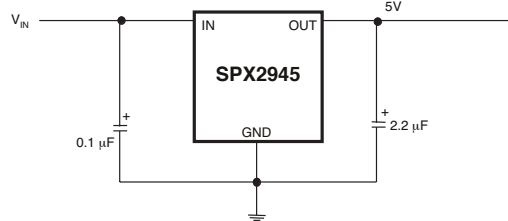

5V Regulator Circuit

Now Available in Lead Free Packaging

DESCRIPTION

The SPX2945 is a low power voltage regulator. This device is an excellent choice for use in battery-powered applications such as cordless telephones, radio control systems, and portable computers. The SPX2945 features very low quiescent current (100 μ A Typ.) and very low dropout voltage. This includes a tight initial tolerance of 1% max and very low output temperature coefficient, making the SPX2945 useful as a low-power voltage reference.

The error flag output feature is used as power-on reset for warning of a low output voltage, due to a falling voltage input of batteries. Another feature is the logic-compatible shutdown input which enables the regulator to be switched on and off. The SPX2945 is offered in 3-pin TO-220 package, SO-8 (same pin out as SPX2951), SOT-223, surface mount 3-Pin TO-252, 3-Pin TO-263 packages and 5-Pin TO-263.

The regulator output voltage (of the 8-pin SO-8) may be pin-strapped for a 3.3V and 5.0V or programmed from 1.24V to 20V with an external pair of resistors. Look for SPX2951 for 150mA and SPX2954 for 250mA applications.

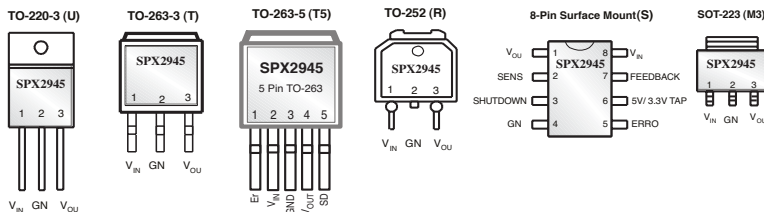

Note: Tab is Ground

ABSOLUTE MAXIMUM RATINGS

Power Dissipation Internally Limited
 Lead Temp. (Soldering, 5 Seconds) 260°C
 Storage Temperature Range -65°C to +150°C
 Operating Junction Temperature Range -40°C to +125°C
 Input Supply Voltage -20V to +26V

Feedback Input Voltage -1.5V to +26V
 Shutdown Input Voltage -0.3V to +26V
 Error Comparator Output -0.3V to +26V
 ESD Rating 2kV Min

ELECTRICAL CHARACTERISTICS

Electrical characteristics at $V_{IN} = V_O + 1V$, $I_O = 1mA$, $C_{OUT} = 2.2\mu F$, $T_A = 25^\circ C$, unless otherwise specified. The ♦ denotes the specifications which apply over full operating temperature range -40°C to +85°C, unless noted.

PARAMETER	CONDITIONS (Note 2)	MIN	TYP	MAX		UNITS
3.3V Version						
Output Voltage	$1mA \leq I_L \leq 400mA$	3.267	3.3	3.333		V
		3.217	3.3	3.382	♦	
5.0V Version						
Output Voltage	$1mA \leq I_L \leq 400mA$	4.950	5.0	5.050		V
		4.880	5.0	5.120	♦	
All Voltage Options						
Output Voltage Temperature Coefficient	(Note1)	20		100	♦	ppm/°C
Line Regulation (Note 3)	$6V \leq V_{IN} \leq 20V$ (Note 4)		1.5	20	♦	mV
Load Regulation (Note 3)	$I_L = 1$ to 400mA		6	20	♦	mV
				30		
Dropout Voltage (Note5)	$I_L = 1mA$		60	100	♦	mV
	$I_L = 400mA$		360	150		
				450	♦	
				700		
Ground Current	$I_L = 1mA$		100	200	♦	μA
				300		
	$I_L = 150mA$		2	4	♦	mA
	$I_L = 300mA$		4	6		
	$I_L = 400mA$		8	12	♦	
				15		
				25	♦	
Current Limit	$V_{OUT} = 0$		330	800	♦	mA
Thermal Regulation			0.05	0.2		%/W
Output Noise, 10Hz to 100kHz, $I_L = 100mA$	$C_L = 2.2\mu F$ $C_L = 33\mu F$		400			μV _{RMS}
			260			
PSRR at 100KHz $I_L = 100mA$	$C_L = 10\mu F$		31			dB
Adjustable 8 Pin Version only						
Reference Voltage		1.210	1.235	1.260		V
Reference Voltage	Over Temperature	1.185		1.285		V
Feedback Pin Bias Current			20	40	♦	nA
				60		
Reference Voltage Temp. Coefficient			20			ppm/°C

ELECTRICAL CHARACTERISTICS: Continued

Electrical characteristics at $V_{IN} = V_O + 1V$, $I_O = 1mA$, $C_{OUT} = 2.2\mu F$, $T_A = 25^\circ C$, unless otherwise specified. ♦ applies over the full operating temperature range.

PARAMETER	CONDITIONS (Note 2)	MIN	TYP	MAX	♦	UNITS
Feedback Pin Bias Current Temperature Coefficient			0.1			nA/°C
Output Leakage Current	$V_{OH}=20V$		0.01	1 2	♦	μA
Output Low Voltage	$V_{IN}=4.5V$ $I_{OL}=400\mu A$		150	250 400	♦	mV
Upper Threshold Voltage	(Note 6)	40 25	60			mV
Lower Threshold Voltage	(Note 6)		75	95 140	♦	mV
Hysteresis	(Note 6)		15			mV
Input Logic Voltage	Low (Regulator ON) High (Regulator OFF)		1.3	0.7 2.0	♦ ♦	V
Shutdown Pin Input Current	$V_S=2.4V$ $V_S=26V$		30 450	50 100 600 750	♦ ♦ ♦	μA
Regulator Output Current in Shutdown	(Note 7)	10 20	3		♦	μA
Thermal Resistance Theta Junction-Ambient θ_{JA}	TO-220-3 TO-263-3 TO-263-5 NSOIC-8 SOT-223 TO-252		29.4 31.4 31.2 128.4 62.3 50		♦ ♦ ♦ ♦ ♦ ♦	°C/W

Note 1: Output or reference voltage temperature coefficients defined as the worst case voltage change divided by the total temperature range.

Note 2: Unless otherwise specified all limits are guaranteed for $T_J = 25^\circ C$, $V_{IN} = 6V$, $I_L = 1mA$ and $C_L = 2.2\mu F$. Additional conditions for the 8-pin versions are feedback tied to 5V/3.3V tap and output tied to output sense ($V_{OUT} = 5V$) and $V_{SHUTDOWN} \leq 0.8V$.

Note 3: Regulation is measured at constant junction temperature, using pulse testing with a low duty cycle. Changes in output voltage due to heating effects are covered under the specification for thermal regulation.

Note 4: Line regulation for the SPX2945 is tested at $150^\circ C$ for $I_L = 1mA$. For $T_J = 125^\circ C$, line regulation is guaranteed by design.

Note 5: Dropout voltage is defined as the input to output differential at which the output voltage drops 100 mV below its nominal value measured at 1V differential at very low values of programmed output voltage, the minimum input supply voltage of 2V (2.3V over temperature) must be taken into account.

Note 6: Comparator thresholds are expressed in terms of a voltage differential at the feedback terminal below the nominal reference voltage measured at 6V input. To express these thresholds in terms of output voltage change, multiply by the error amplifier gain $= V_{OUT}/V_{REF} = (R1 + R2)/R2$. For example, at a programmed output voltage of 5V, the Error output is guaranteed to go low when the output drops by $95mV \times 5V/1.235 = 384mV$. Thresholds remain constant as a percent of V_{OUT} as V_{OUT} is varied, with the dropout warning occurring at typically 5% below nominal, 7.5% guaranteed.

Note 7: $V_{SHUTDOWN} \geq 2V$, $V_{IN} \leq 26V$, $V_{OUT} = 0$, Feedback pin tied to 5V/3.3V Tap.

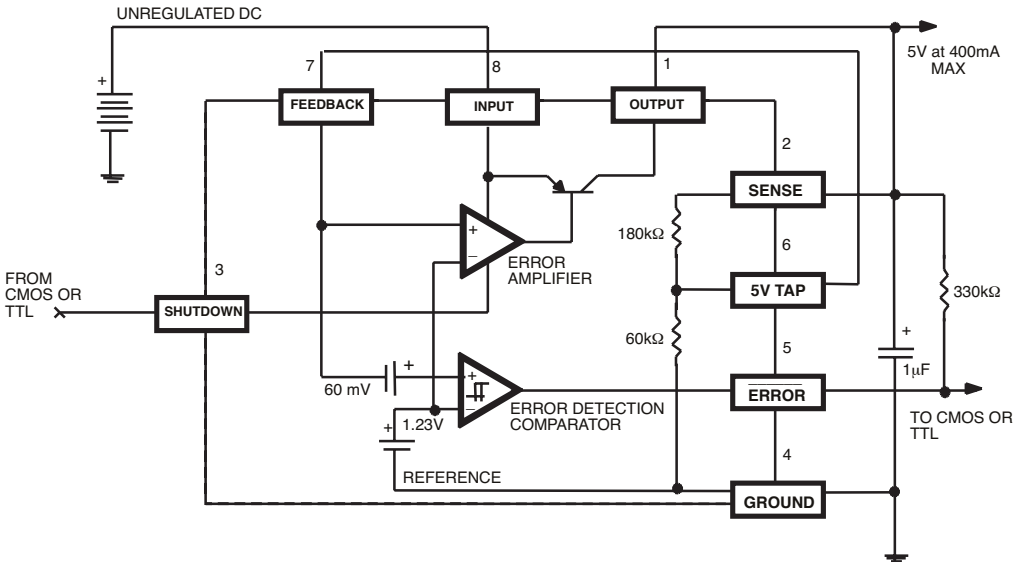

APPLICATION INFORMATION

External Capacitors

The stability of the SPX2945 requires a 2.2µF or greater capacitor between output and ground. Oscillation could occur without this capacitor. Most types of tantalum or aluminum electrolytic works fine here. For operations of below -25°C solid tantalum is recommended since the many aluminum types have electrolytes that freeze at about -30°C. The ESR of about 5Ω or less and resonant frequency above 500kHz are the most important parameters in the value of the capacitor. The capacitor value can be increased without limit.

At lower values of output current, less output capacitance is required for stability. For the currents below 10mA the value of the capacitor can be reduced to 0.5µF and 0.15µF for 1mA. More output capacitance needed for the 8-pin version at voltages below 5V since it runs the error amplifier at lower gain. At worst case 4.7µF or greater must be used for the condition of 250mA load at 1.23V output.

The SPX2945, unlike other low dropout regulators will remain stable and in regulation with no load in addition to the internal voltage divider. This feature is especially important in applications like CMOS RAM keep-alive.

If there is more than 10 inches of wire between the input and the AC filter capacitor, or if a battery is used as the input, then a 0.1µF tantalum or aluminum electrolytic capacitor should be placed from the input to the ground.

Instability can occur if there is stray capacitance to the SPX2945 feedback terminal (pin 7). This could cause more problems when using a higher value of external resistors to set the output voltage.

This problem can be fixed by adding a 100pF capacitor between output and feedback and increasing the output capacitor to at least 3.3µF.

Error Detection Comparator Output

The Comparator produces a logic low output whenever the SPX2945 output falls out of regulation by more than around 5%. This is around 60mV offset divided by the 1.235 reference voltage. This trip level remains 5% below normal regardless of the programmed output voltage of the regulator. Figure 1 shows the timing diagram depicting the ERROR signal and the regulator output voltage as the SPX2945 input is ramped up and down. The ERROR signal becomes low at around 1.3V input, and goes high around 5V input (input voltage at which $V_{OUT} = 4.75$). Since the SPX2945's dropout voltage is load dependent, the input voltage trip point (around 5V) will vary with the load current. The output voltage trip point (approx. 4.75V) does not vary with load.

The error comparator has an open-collector output, which requires an external pull-up resistor. Depending on the system requirements the resistor may be returned to 5V output or other supply voltage. In determining the value of this resistor, note that the output is rated to sink 400 μ A; this value adds to battery drain in a low battery condition. Suggested values range from 100K to 1M Ω . If the output is unused this resistor is not required.

Programming the Output Voltage of SPX2945

The SPX2945 may be pin-strapped for 5V or 3.3V using its internal voltage divider by tying Pin 1 (output) to Pin 2 (sense) and Pin 7 (feedback) to Pin 6 (5V/3.3V Tap).

Also, it may be programmed for any output voltage between its 1.235V reference and its 20V maximum rating. As seen in Figure 2, an external pair of resistors is required.

Refer to the below equation for the programming of the output voltage::

$$V_{OUT} = V_{REF} \times (1 + R_1/R_2) + I_{FB}R_1$$

The V_{REF} is 1.235 and I_{FB} is the feedback bias current, nominally -20nA. The minimum recommended load current of 1 μ A forces an upper limit of 1.2 M Ω on value of R_2 . If no load is presented the I_{FB} produces an error of typically

2% in V_{OUT} , which may be eliminated at room temperature by trimming R_1 . To improve the accuracy choose the value of $R_2 = 100k$; this reduces the error by 0.17% and increases the resistor program current by 12 μ A. Since the SPX2945 typically draws 60 μ A at no load with Pin 2 open-circuited this is a small price to pay.

Reducing Output Noise

It may be an advantage to reduce the AC noise present at the output. One way is to reduce the regulator bandwidth by increasing the size of the output capacitor. This is the only way that noise can be reduced on the 3 lead SPX2945 but is relatively inefficient, as increasing the capacitor from 1 μ F to 220 μ F only decreases the noise from 430 μ V to 160 μ V Vrms for a 100kHz bandwidth at 5V output. Noise could also be reduced fourfold by a bypass capacitor across R_1 , since it reduces the high frequency gain from 4 to unity. Pick

$$C_{BYPASS} \cong 1 / 2\pi R_1 \times 200 \text{ Hz}$$

or choose 0.01 μ F. When doing this, the output capacitor must be increased to 3.3 μ F to maintain stability. These changes reduce the output noise from 430 μ V to 100 μ V Vrms for a 100kHz bandwidth at 5V output. With the bypass capacitor added, noise no longer scales with output voltage so that improvements are more dramatic at higher output voltages.

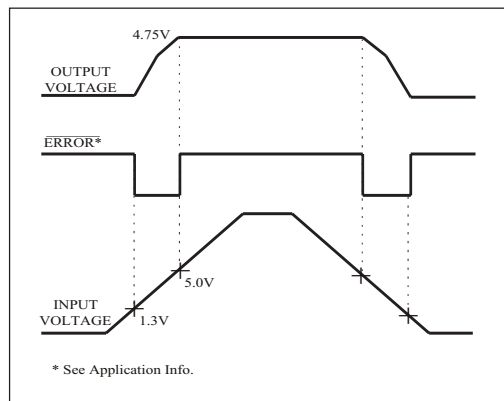
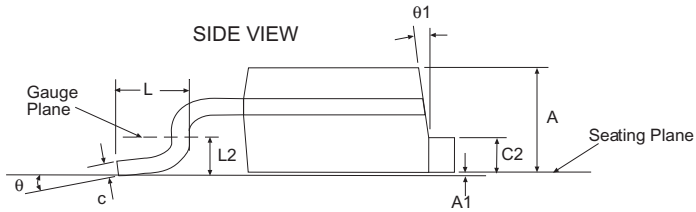
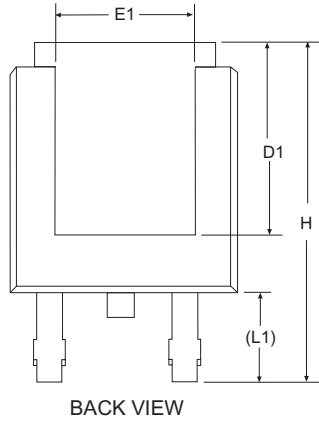
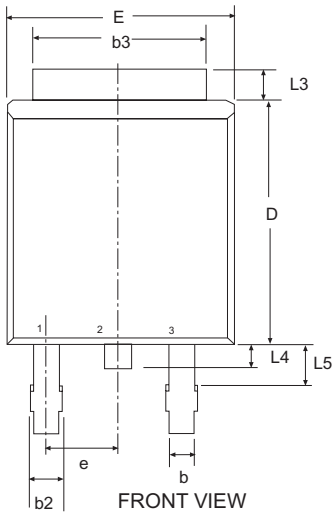
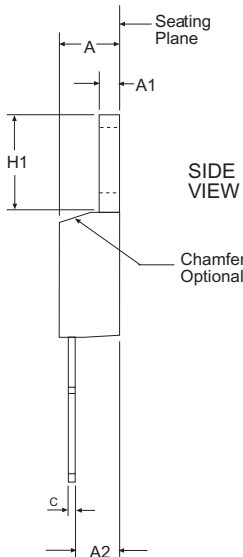
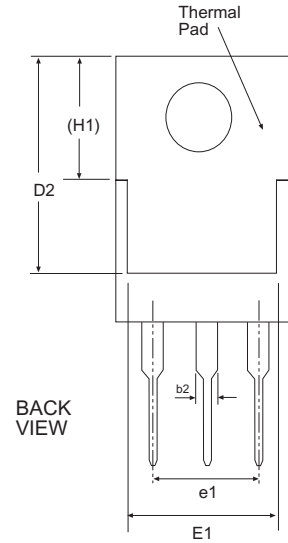
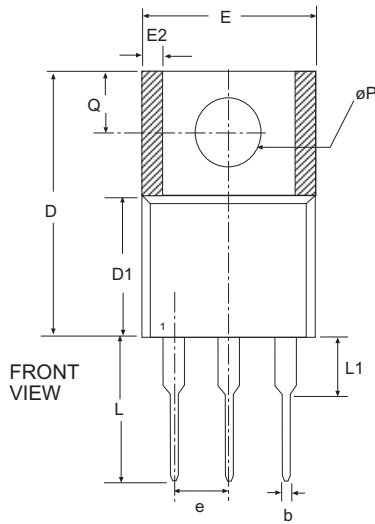

Figure 1. ERROR Output Timing



SYMBOL	3 Pin TO-252			JEDEC TO-252			Variation AA		
	Dimensions in Inches: Controlling Dimension			Dimensions in Millimeters Conversion Factor: 1 Inch = 25.40 mm					
	MIN	NOM	MAX	MIN	NOM	MAX			
A	0.086	-	0.094	2.18	-	2.39			
A1	-	-	0.005	-	-	0.13			
b	0.025	-	0.035	0.64	-	0.89			
b2	0.030	-	0.045	0.76	-	1.14			
b3	0.195	-	0.215	4.95	-	5.46			
c	0.018	-	0.024	0.46	-	0.61			
c2	0.018	-	0.035	0.46	-	0.89			
D	0.235	0.240	0.245	5.97	6.10	6.22			
D1	0.205	-	-	5.21	-	-			
E	0.250	-	0.265	6.35	-	6.73			
E1	0.170	-	-	4.32	-	-			
e	.090 BSC			2.29 BSC					
H	0.370	-	0.410	9.4	-	10.41			
L	0.055	0.060	0.070	1.4	1.52	1.78			
L1	.108 REF			2.74 REF					
L2	.020 BSC			0.51 BSC					
L3	0.035	-	0.050	0.89	-	1.27			
L4	-	-	0.040	-	-	1.02			
L5	0.045	-	0.060	1.14	-	1.52			
ø	0°	-	10°	0°	-	10°			
ø1	0°	-	15°	0°	-	15°			
SIPEX Pkg Signoff Date/Rev:				JL Aug4-05/Rev A					



SYMBOL	3 Pin TO-220			JEDEC TO-220			Variation AB		
	Dimensions in Inches: Controlling Dimension			Dimensions in Millimeters: Conversion Factor: 1 Inch = 25.40 mm					
	MIN	NOM	MAX	MIN	NOM	MAX	MIN	NOM	MAX
A	0.140	-	0.190	3.56	-	4.83			
A1	0.020	-	0.055	0.51	-	1.27			
A2	0.080	-	0.115	2.03	-	2.79			
b	0.015	0.027	0.040	0.25	0.51	1.02			
b2	0.045	0.057	0.070	1.14	1.45	1.78			
c	0.014	-	0.024	0.25	-	0.51			
D	0.560	-	0.650	14.22	-	16.51			
D1	0.330	-	0.355	8.38	-	8.89			
D2	0.480	-	0.507	12.19	-	12.70			
E	0.380	-	0.420	9.65	-	10.67			
E1	0.270	-	0.350	6.86	-	8.89			
E2	-	-	0.030	-	-	0.76			
e	.100 BSC			2.54 BSC					
e1	.200 BSC			5.08 BSC					
H1	0.230	-	0.270	5.84	-	6.86			
L	0.500	-	0.580	12.70	-	14.73			
L1	-	-	0.250	-	-	6.35			
ϕP	0.139	-	0.161	3.30	-	4.06			
Q	0.100	-	0.135	2.54	-	3.30			
SIPEX Pkg Signoff Date/Rev:				JL Aug4-05 / Rev A					

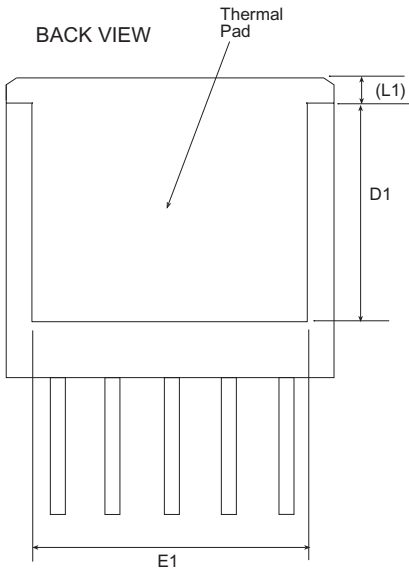
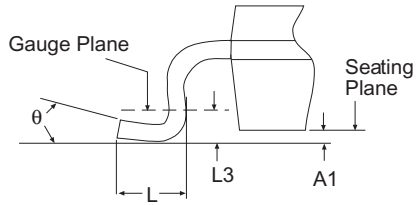
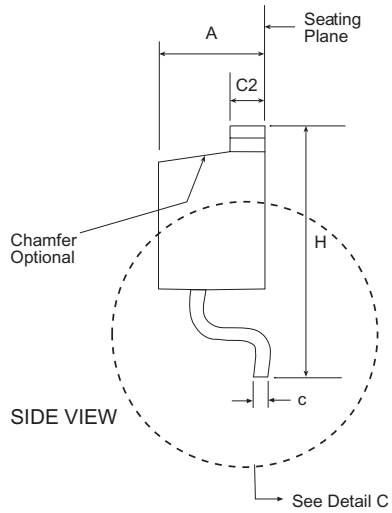
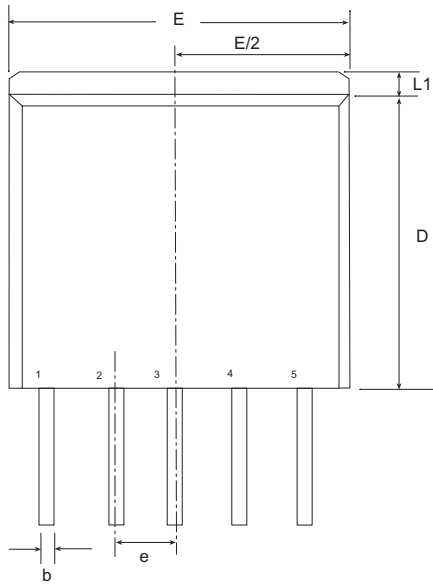

5 Pin TO-263 JEDEC TO-263			Variation BA			
SYMBOL	Inches Controlling Dimension			Millimeters Conversion Factor: 1 Inch = 25.40 mm		
	MIN	NOM	MAX	MIN	NOM	MAX
A	0.160	-	0.190	4.06	-	4.83
A1	0.000	-	0.010	0.00	-	0.25
b	0.020	-	0.039	0.51	-	0.99
c	0.015	-	0.029	0.38	-	0.74
c2	0.045	-	0.065	11.43	-	5.84
D	0.330	-	0.380	8.38	-	9.65
D1	0.270	-	-	6.86	-	-
E	0.380	-	0.420	9.65	-	10.67
E1	0.245	-	-	6.22	-	-
e	.067 BSC			17.02 BSC		
H	0.575	-	0.625	14.61	-	15.88
L	0.070	-	0.110	1.78	-	2.79
L1	-	-	0.066	-	-	1.68
L3	.010 BSC			2.54 BSC		
θ	0°	-	8°	0°	-	8°
SIPEX Pkg Signoff Date/Rev:				JL Jan18-06/Rev A		

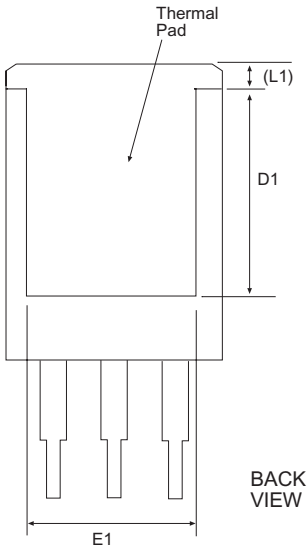
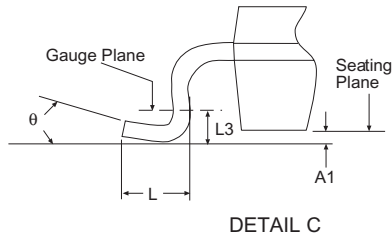
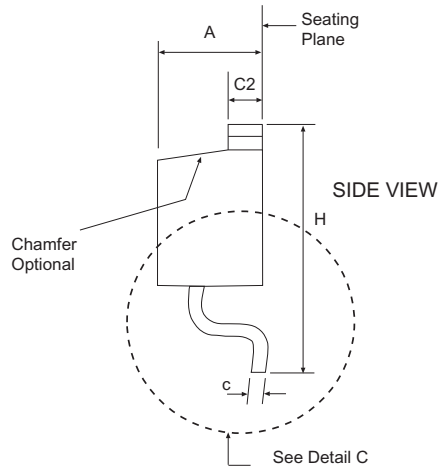
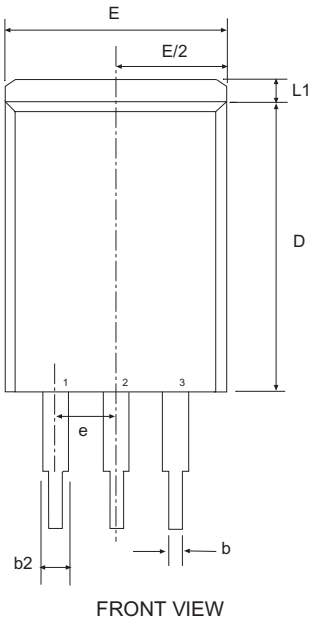

3 Pin TO-263 JEDEC TO-263			Variation AA			
SYMBOL	Inches Controlling Dimension			Millimeters Conversion Factor: 1 Inch = 25.40 mm		
	MIN	NOM	MAX	MIN	NOM	MAX
A	0.160	-	0.190	4.06	-	4.83
A1	0.000	-	0.010	0.00	-	0.25
b	0.020	-	0.039	0.51	-	0.99
b2	0.045	-	0.070	1.14	-	1.78
c	0.015	-	0.029	0.38	-	0.74
c2	0.045	-	0.065	1.14	-	1.65
D	0.330	-	0.380	8.38	-	9.65
D1	0.270	-	-	6.86	-	-
E	0.380	-	0.420	9.65	-	10.67
E1	0.245	-	-	6.22	-	-
e	.100 BSC			2.54 BSC		
H	0.575	-	0.625	14.61	-	15.88
L	0.070	-	0.110	1.78	-	2.79
L1	-	-	0.066	-	-	1.68
L3	.010 BSC			0.25 BSC		
θ	0°	-	8°	0°	-	8°
SIPEX Pkg Signoff Date/Rev:				JL Aug5-05 / Rev A		

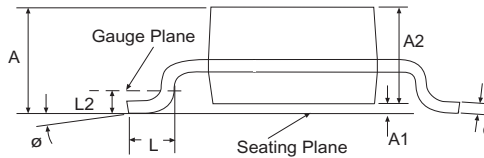
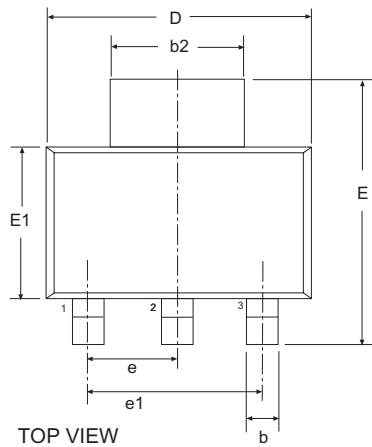

FRONT VIEW

		3 Pin SOT-223		JEDEC TO-261		Variation AA	
SYMBOL	Millimeters Controlling Dimension			Inches Conversion Factor: 1 Inch = 25.40 mm			
	MIN	NOM	MAX	MIN	NOM	MAX	
A	-	-	1.80	-	-	0.071	
A1	0.02	-	0.10	0.001	-	0.004	
A2	1.50	1.60	1.70	0.060	0.063	0.067	
b	0.66	0.76	0.84	0.026	0.030	0.033	
b2	2.90	3.00	3.10	0.114	0.118	0.122	
c	0.23	0.30	0.35	0.010	0.012	0.014	
D	6.30	6.50	6.70	0.248	0.256	0.264	
E	6.70	7.00	7.30	0.264	0.276	0.287	
E1	3.30	3.50	3.70	0.130	0.138	0.146	
e	2.30 BASIC			0.091 BASIC			
e1	4.60 BASIC			0.182 BASIC			
L	0.75	-	-	0.030	-	-	
L2	0.25 BASIC			0.010 BASIC			
ø	0°	-	10°	0°	-	10°	
SIPEX Pkg Signoff Date/Rev:				JL Aug8-05/Rev A			

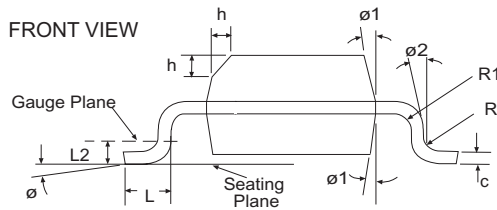
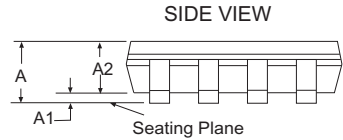
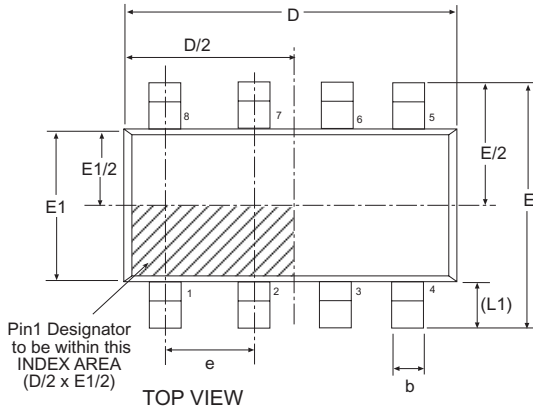

8 Pin NSOIC		JEDEC MS-012		Variation AA		
SYMBOL	Dimensions in Millimeters: Controlling Dimension			Dimensions in Inches Conversion Factor: 1 Inch = 25.40 mm		
	MIN	NOM	MAX	MIN	NOM	MAX
A	1.35	-	1.75	0.053	-	0.069
A1	0.10	-	0.25	0.004	-	0.010
A2	1.25	-	1.65	0.049	-	0.065
b	0.31	-	0.51	0.012	-	0.020
c	0.17	-	0.25	0.007	-	0.010
E	6.00 BSC			0.236 BSC		
E1	3.90 BSC			0.154 BSC		
e	1.27 BSC			0.050 BSC		
h	0.25	-	0.50	0.010	-	0.020
L	0.40	-	1.27	0.016	-	0.050
L1	1.04 REF			0.041 REF		
L2	0.25 BSC			0.010 BSC		
R	0.07	-	-	0.003	-	-
R1	0.07	-	-	0.003	-	-
ϕ	0°	-	8°	0°	-	8°
$\phi 1$	5°	-	15°	5°	-	15°
$\phi 2$	0°	-	-	0°	-	-
D	4.90 BSC			0.193 BSC		
SIPLEX Pkg Signoff Date/Rev:				JL Aug16-05 / Rev A		

ORDERING INFORMATION

Ordering No.	Accuracy	Output Voltage	Packages
SPX2945M3-3-3	1%	3.3V	3-Pin SOT-223
SPX2945M3-3-3/TR	1%	3.3V	3-Pin SOT-223
SPX2945M3-5-0	1%	5.0V	3-Pin SOT-223
SPX2945M3-5-0/TR	1%	5.0V	3-Pin SOT-223
SPX2945S-3-3	1%	3.3V	8-Pin NSOIC
SPX2945S-3-3/TR	1%	3.3V	8-Pin NSOIC
SPX2945S-5-0	1%	5.0V	8-Pin NSOIC
SPX2945S-5-0/TR	1%	5.0V	8-Pin NSOIC
SPX2945R-3-3	1%	3.3V	3-Pin TO-252
SPX2945R-3-3/TR	1%	3.3V	3-Pin TO-252
SPX2945R-5-0	1%	5.0V	3-Pin TO-252
SPX2945R-5-0/TR	1%	5.0V	3-Pin TO-252
SPX2945T-3-3	1%	3.3V	3-Pin TO-263
SPX2945T-3-3/TR	1%	3.3V	3-Pin TO-263
SPX2945T-5-0	1%	5.0V	3-Pin TO-263
SPX2945T-5-0/TR	1%	5.0V	3-Pin TO-263
SPX2945T5-3-3	1%	3.3V	5-Pin TO-263
SPX2945T5-3-3/TR	1%	3.3V	5-Pin TO-263
SPX2945T5-5-0	1%	5.0V	5-Pin TO-263
SPX2945T5-5-0/TR	1%	5.0V	5-Pin TO-263
SPX2945U-3-3	1%	3.3V	3-Pin TO-220
SPX2945U-5-0	1%	5.0V	3-Pin TO-220

Available in lead free packaging. To order add "-L" suffix to part number.

Example: SPX2954S-5-0/TR = standard; SPX2954S-L-5-0/TR = lead free

/TR = Tape and Reel

Pack quantity is 500 for TO-263, 2,000 for TO-252, and 2,500 for SOT223 or NSOIC.



Solved By Sipex™

Sipex Corporation

**Headquarters and
Sales Office**
233 South Hillview Drive
Milpitas, CA 95035
TEL: (408) 934-7500
FAX: (408) 935-7600

Sipex Corporation reserves the right to make changes to any products described herein. Sipex does not assume any liability arising out of the application or use of any product or circuit described herein; neither does it convey any license under its patent rights nor the rights of others.

X-ON Electronics

Largest Supplier of Electrical and Electronic Components

Click to view similar products for [LDO Voltage Regulators](#) category:

Click to view products by [MaxLinear](#) manufacturer:

Other Similar products are found below :

[AP7363-SP-13](#) [L79M05TL-E](#) [PT7M8202B12TA5EX](#) [TCR3DF185,LM\(CT](#) [MP2013GQ-33-Z](#) [059985X](#) [NCP4687DH15T1G](#) [701326R](#)
[TCR2EN28,LF\(S](#) [NCV8170AXV250T2G](#) [TCR2EN18,LF\(S](#) [AP7315-25W5-7](#) [IFX30081LDVGRNXUMA1](#) [NCV47411PAAJR2G](#)
[AP2113KTR-G1](#) [AP2111H-1.2TRG1](#) [ZLDO1117QK50TC](#) [AZ1117IH-1.8TRG1](#) [TCR3DG12,LF](#) [MIC5514-3.3YMT-T5](#) [MIC5512-1.2YMT-](#)
[T5](#) [MIC5317-2.8YM5-T5](#) [SCD7912BTG](#) [NCP154MX180270TAG](#) [SCD33269T-5.0G](#) [NCV8170BMX330TCG](#) [NCV8170AMX120TCG](#)
[NCP706ABMX300TAG](#) [NCP153MX330180TCG](#) [NCP114BMX075TCG](#) [MC33269T-3.5G](#) [CAT6243-ADJCMT5T](#) [TCR3DG33,LF](#)
[AP2127N-1.0TRG1](#) [TCR4DG35,LF](#) [LT1117CST-3.3](#) [LT1117CST-5](#) [TAR5S15U\(TE85L,F\)](#) [TAR5S18U\(TE85L,F\)](#) [TCR3UG19A,LF](#)
[TCR4DG105,LF](#) [NCV8170AMX360TCG](#) [MIC94310-NYMT-T5](#) [NCV8186BMN175TAG](#) [NCP715SQ15T2G](#) [MIC5317-3.0YD5-T5](#)
[NCV563SQ18T1G](#) [MIC5317-2.8YD5-T5](#) [NCP715MX30TBG](#) [MIC5317-2.5YD5-T5](#)