

5V Micropower Voltage Reference

FEATURES

- Trimmed Bandgap 1%
- Wide Operating Current 50µA to 20mA
- Extended Temperature Range ... -40°C to +85°C
- Dynamic Impedance 1Ω max
- Offered in Small SOT-23, TO-92, NSOIC, and SOT-89
- Low Cost Solution

APPLICATIONS

- Battery Operated Equipment
- Adjustable Supplies
- Switching Power Supplies
- Error Amplifiers
- Single Supply Amplifier

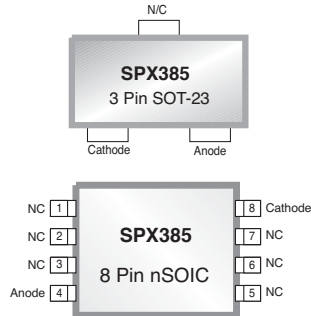

Now Available in Lead Free Packaging

- Monitors / VCR / TV
- Personal Computers
- Power use meter

DESCRIPTION

The SPX385-5.0 is a micropower 2-terminal band-gap voltage reference with a very wide operating current range from 50µA to 20mA that provides a stable voltage.

The SPX385-5.0 is available in SOT-23, TO-92, NSOIC, and SOT-89 packages with an operating temperature range of -40°C to 85°C. A 1.2 and 2.5 volt device are also available - SPX385-1.2, SPX385-2.5.

BLOCK DIAGRAM

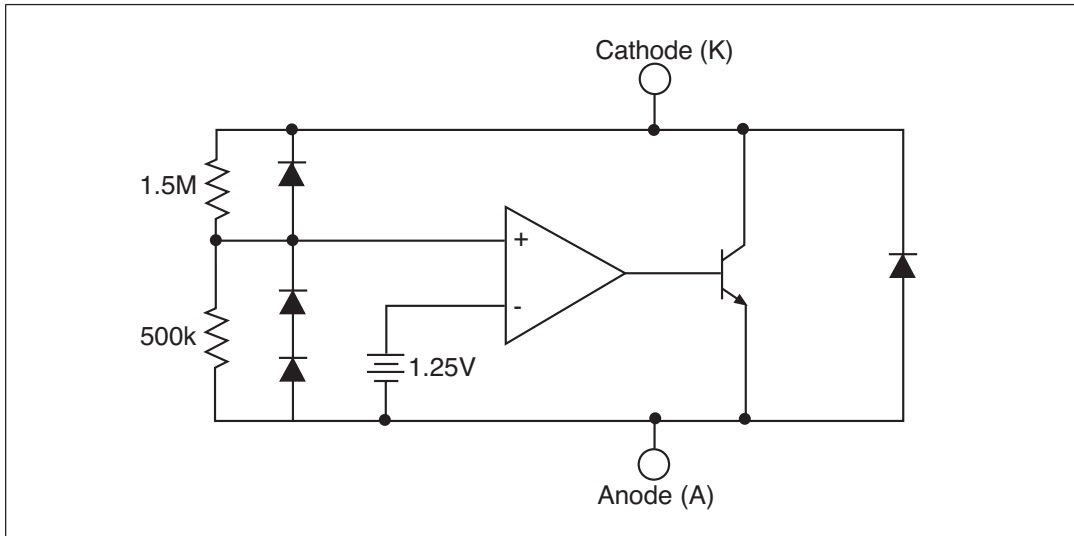

Figure 1: Block Diagram

ABSOLUTE MAXIMUM RATINGS

Stresses greater than those listed under ABSOLUTE MAXIMUM RATINGS may cause permanent damage to the device. This is a stress rating only and functional operation of the device at these or any other conditions above those indicated in the operational sections of this specification is not implied. Exposure to absolute maximum rating conditions for extended periods may affect reliability.

Reverse Current (I_{KA})	30mA
Forward Current (I_{AK})	10mA
Operating Temperature Range (T_A)	-40 to +85°C
Junction Temperature (T_J)	150°C
Storage Temperature (T_{STG})	- 65 to 150°C
Lead Temperature (Soldering 10 sec.), T_L	300°C

ELECTRICAL CHARACTERISTICS

$I_{IN} = 100\mu A$, $T_A = 25^\circ C$, unless otherwise specified. The \blacklozenge denotes the specifications which apply over the full operating temperature range.

PARAMETER	MIN.	TYP.	MAX		UNIT	CONDITIONS
Reference Voltage	4.90 4.95	5.00 5.00	5.10 5.05	\blacklozenge	V	2% 1%
Dynamic Output Impedance		0.6	1.0	\blacklozenge \blacklozenge	Ω	$F = 20\text{Hz}$ $I_R = 100\mu A$
Reference Voltage Change with I_R		10	20	\blacklozenge	mV	$20\mu A \leq I_R \leq 20\text{mA}$
Temperature Coefficient		30	50	\blacklozenge	ppm/ $^\circ C$	Note 1
Minimum Operating Current	30		50	\blacklozenge	μA	
Output Wideband Noise		120		\blacklozenge	μV_{rms}	$10\text{Hz} \leq f \leq 10\text{kHz}$
Long Term Stability		60		\blacklozenge	ppm	$T = 1000\text{Hr};$ $T_A = 25^\circ C \pm 0.1^\circ C$
Operating Temperature	-40		+85		$^\circ C$	

Note 1. Three-point measurement guarantees the error band over the specified temperature range.

*CALCULATING AVERAGE TEMPERATURE COEFFICIENT (TC)

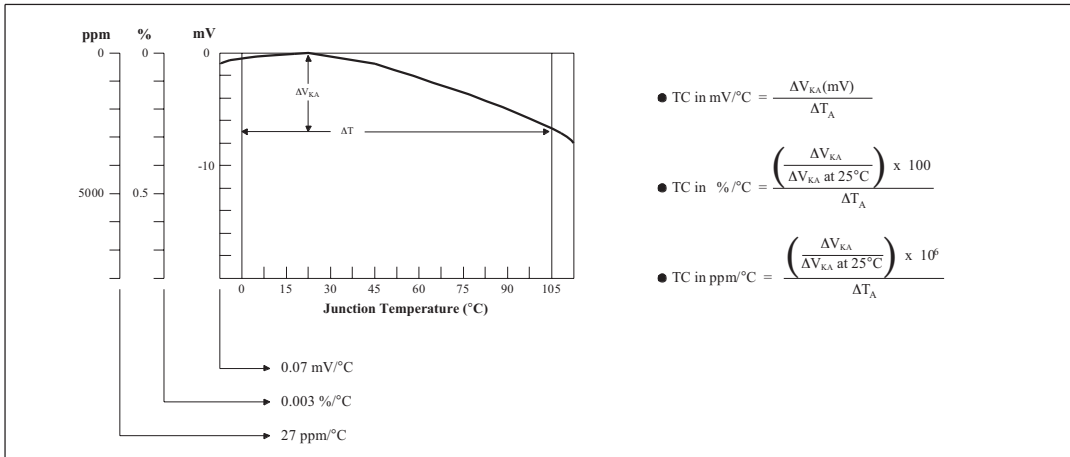

Figure 2. V_{KA} vs. Temperature

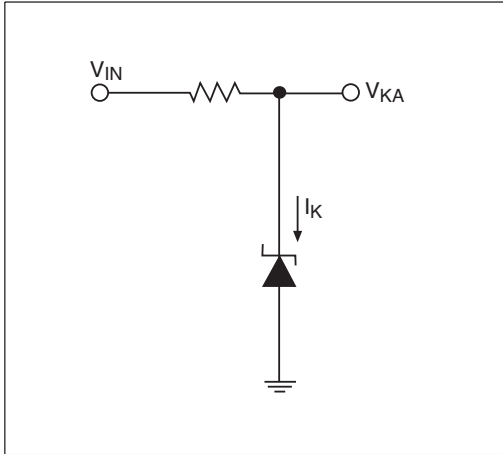

Figure 1. Improving Regulation of Adjustable Regulators

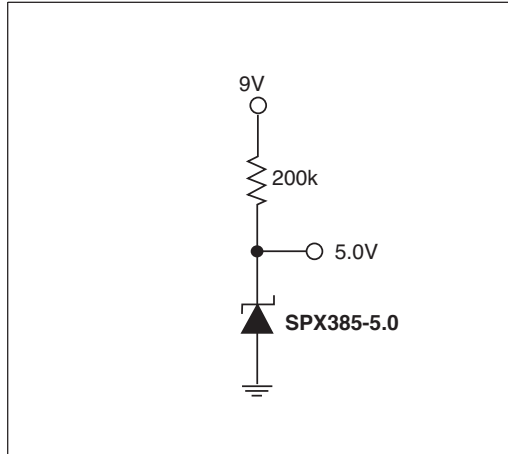

Figure 2. Micropower Reference from 9V Battery

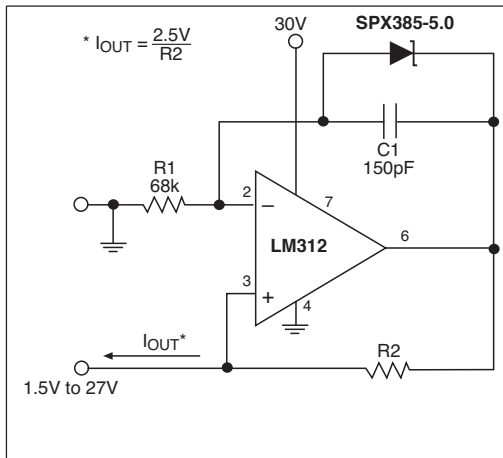

Figure 3. Precision $I_{\mu A}$ to 1mA Current Source

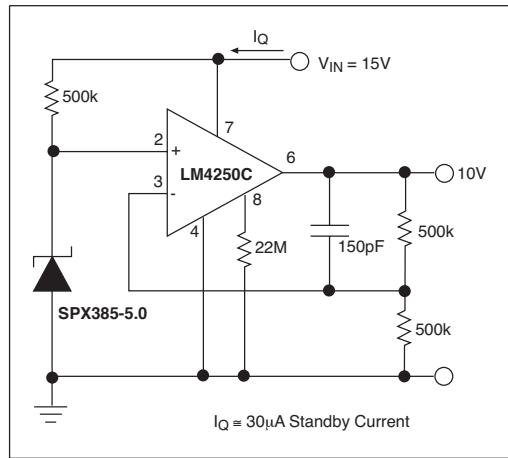
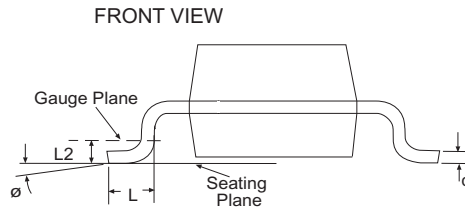
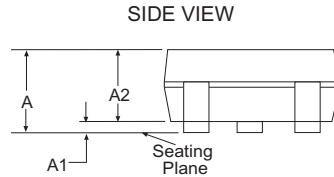
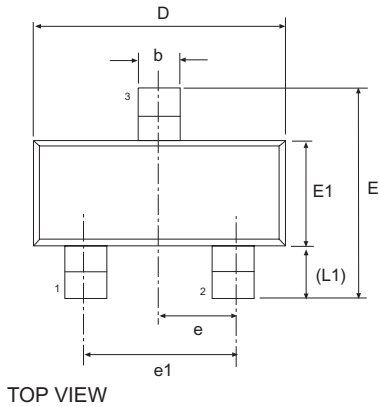
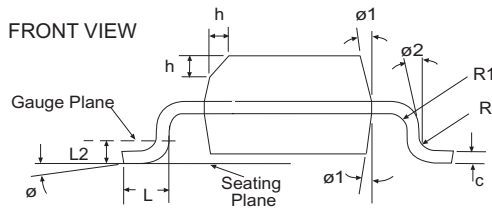
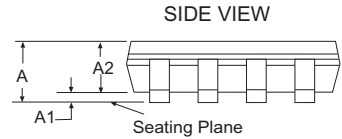
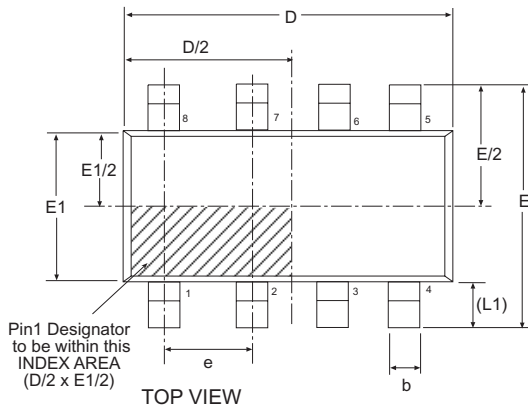

Figure 4. Precision Micropower 10V Reference



3 Pin SOT-23		JEDEC TO-236		Variation AB		
SYMBOL	Dimensions in Millimeters: Controlling Dimension			Dimensions in Inches Conversion Factor: 1 Inch = 25.40 mm		
	MIN	NOM	MAX	MIN	NOM	MAX
b	0.30	-	0.50	0.012	-	0.020
c	0.08	-	0.20	0.003	-	0.008
D	2.80	2.90	3.04	0.110	0.114	0.120
E	2.10	-	2.64	0.083	-	0.104
E1	1.20	1.30	1.40	0.047	0.051	0.055
e	0.95 BSC			0.038 BSC		
e1	1.90 BSC			0.075 BSC		
L	0.40	0.50	0.60	0.016	0.020	0.024
L1	0.54 REF			0.021 REF		
L2	0.25 BSC			0.010 BSC		
Ø	0°	-	8°	0°	-	8°
A	0.89	-	1.12	0.035	-	0.044
A1	0.01	-	0.10	0.000	-	0.004
A2	0.88	0.95	1.02	0.035	0.037	0.040
SIPEX Pkg Signoff Date/Rev:				JL Oct25-05 / Rev A		



8 Pin NSOIC		JEDEC MS-012		Variation AA		
SYMBOL	Dimensions in Millimeters: Controlling Dimension			Dimensions in Inches Conversion Factor: 1 Inch = 25.40 mm		
	MIN	NOM	MAX	MIN	NOM	MAX
A	1.35	-	1.75	0.053	-	0.069
A1	0.10	-	0.25	0.004	-	0.010
A2	1.25	-	1.65	0.049	-	0.065
b	0.31	-	0.51	0.012	-	0.020
c	0.17	-	0.25	0.007	-	0.010
E	6.00 BSC			0.236 BSC		
E1	3.90 BSC			0.154 BSC		
e	1.27 BSC			0.050 BSC		
h	0.25	-	0.50	0.010	-	0.020
L	0.40	-	1.27	0.016	-	0.050
L1	1.04 REF			0.041 REF		
L2	0.25 BSC			0.010 BSC		
R	0.07	-	-	0.003	-	-
R1	0.07	-	-	0.003	-	-
ϕ	0°	-	8°	0°	-	8°
$\phi 1$	5°	-	15°	5°	-	15°
$\phi 2$	0°	-	-	0°	-	-
D	4.90 BSC			0.193 BSC		
SIPEX Pkg Signoff Date/Rev:				JL Aug16/05 / Rev A		

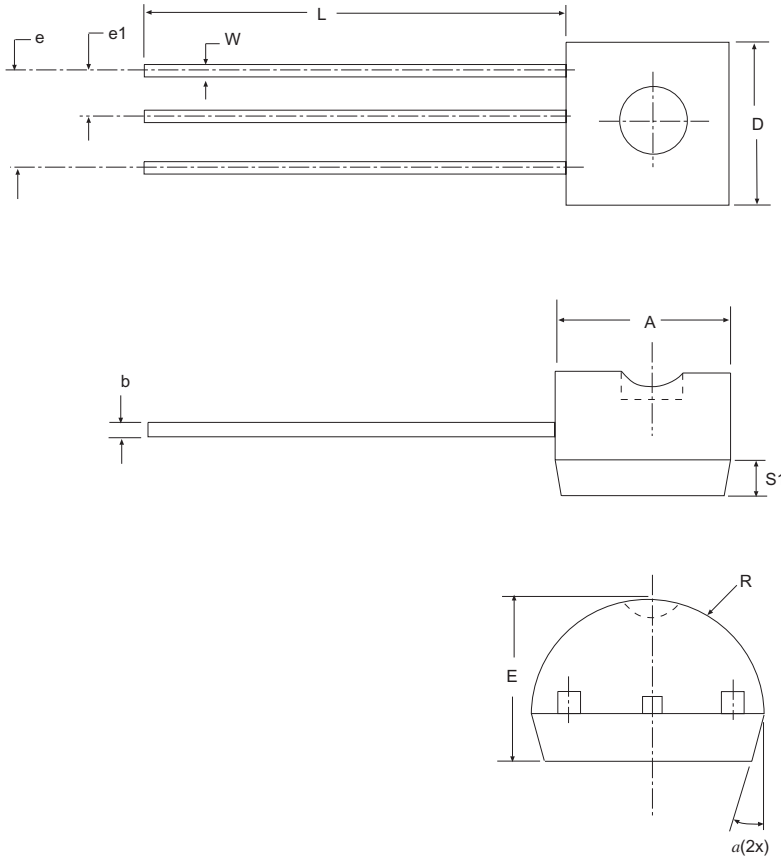

3 Pin TO-92						
SYMBOL	Dimensions in Inches: Controlling Dimension			Dimensions in Millimeters Conversion Factor: 1 Inch = 25.40 mm		
	MIN	NOM	MAX	MIN	NOM	MAX
A	0.170	-	0.195	4.32	-	4.95
b	0.014	-	0.020	0.36	-	0.51
E	0.130	-	0.155	3.30	-	3.94
e	0.095	-	0.105	2.41	-	2.67
e1	0.045	-	0.055	1.14	-	1.40
L	0.500	-	0.610	12.70	-	15.49
R	0.085	-	0.095	2.16	-	2.41
S1	0.045	-	0.060	1.14	-	1.52
W	0.016	-	0.022	0.41	-	0.56
D	0.175	-	0.195	4.45	-	4.95
α	4°	-	6°	4°	-	6°

SIPEX Pkg Signoff Date/Rev: JL Sept23-05 / RevA

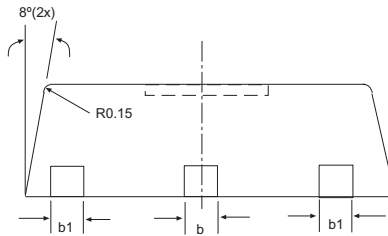
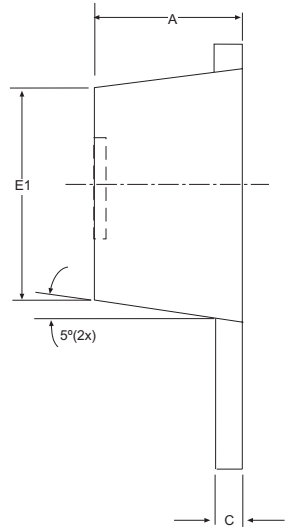
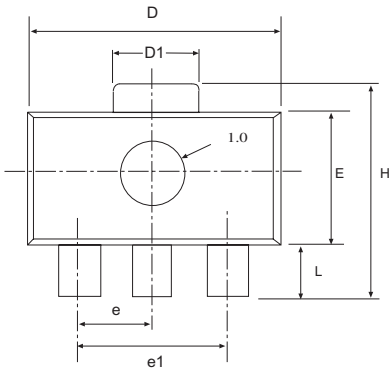

3 Pin SOT-89		JEDEC TO-243			Variation AA		
SYMBOL	Dimensions in Millimeters: Controlling Dimension			Dimensions in Inches Conversion Factor: 1 Inch = 25.40 mm			
	MIN	NOM	MAX	MIN	NOM	MAX	
A	1.40	-	1.60	0.055	-	0.063	
B	0.44	-	0.56	0.017	-	0.022	
B1	0.36	-	0.48	0.014	-	0.019	
C	0.35	-	0.44	0.014	-	0.017	
D	4.40	-	4.60	0.173	-	0.181	
D1	1.62	-	1.83	0.064	-	0.072	
E	2.29	-	2.60	0.090	-	0.102	
E1	2.13	-	2.29	0.084	-	0.090	
e	1.50 BSC			0.059 BSC			
e1	3.00 BSC			0.118 BSC			
H	3.94	-	4.25	0.155	-	0.167	
L	0.89	-	1.20	0.035	-	0.047	
SIPEX Pkg Signoff Date/Rev:				JL Feb2-06/ RevA			

Part Number	Accuracy	Output Voltage	Package Type
SPX385AM-5-0	1.0%	5.0V	3 Pin SOT-23
SPX385AM-5-0/TR	1.0%	5.0V	3 Pin SOT-23
SPX385AM1-5-0	1.0%	5.0V	3 Pin SOT-89
SPX385AM1-5-0/TR	1.0%	5.0V	3 Pin SOT-89
SPX385AN-5-0	1.0%	5.0V	3 Pin TO-92
SPX385AN-5-0/TR	1.0%	5.0V	3 Pin TO-92
SPX385AS-5-0	1.0%	5.0V	8 Pin NSOIC
SPX385AS-5-0/TR	1.0%	5.0V	8 Pin NSOIC
SPX385BM-5-0	2.0%	5.0V	3 Pin SOT-23
SPX385BM-5-0/TR	2.0%	5.0V	3 Pin SOT-23
SPX385BM1-5-0	2.0%	5.0V	3 Pin SOT-89
SPX385BM1-5-0/TR	2.0%	5.0V	3 Pin SOT-89
SPX385BN-5-0	2.0%	5.0V	3 Pin TO-92
SPX385BN-5-0/TR	2.0%	5.0V	3 Pin TO-92
SPX385BS-5-0	2.0%	5.0V	8 Pin NSOIC
SPX385BS-5-0/TR	2.0%	5.0V	8 Pin NSOIC
SPX385M-5-0	2.0%	5.0V	3 Pin SOT-23
SPX385M-5-0/TR	2.0%	5.0V	3 Pin SOT-23
SPX385N-5-0	2.0%	5.0V	3 Pin TO-92
SPX385N-5-0/TR	2.0%	5.0V	3 Pin TO-92
SPX385S-5-0	2.0%	5.0V	8 Pin NSOIC
SPX385S-5-0/TR	2.0%	5.0V	8 Pin NSOIC

Available in lead free packaging. To order add "-L" suffix to part number.
 Example: SPX385BS-5-0/TR = standard; SPX385BS-L-5-0/TR = lead free

/TR = Tape and Reel

Pack quantity is 2,000 for TO-92 and 2,500 NSOIC, SOT-23, SOT-89.



ANALOG EXCELLENCE

Sipex Corporation

Sipex Corporation

**Headquarters and
 Sales Office:**
 233 Hillview Dr
 Milpitas, CA 95035
 TEL: (408) 934-7500
 FAX: (408) 935-7600

Sipex Corporation reserves the right to make changes to any products described herein. Sipex does not assume any liability arising out of the application or use of any product or circuit described herein; neither does it convey any license under its patent rights nor the rights of others.

X-ON Electronics

Largest Supplier of Electrical and Electronic Components

Click to view similar products for [Voltage References](#) category:

Click to view products by [MaxLinear](#) manufacturer:

Other Similar products are found below :

[REF01J/883](#) [5962-8686103XC](#) [NCV431BVDMR2G](#) [LT6654AMPS6-2.048#TRMPBF](#) [SCV431AIDMR2G](#) [LT1019AIS8-2.5](#)
[LT6654AMPS6-3.3#TRM](#) [SC431ILPRAG](#) [AP432AQG-7](#) [LM4040B25QFTA](#) [NJM2823F-TE1](#) [TL431-A](#) [MCP1502T-18E/CHY](#) [MCP1502T-40E/CHY](#) [TL4050B25QDBZR](#) [TL431ACZ](#) [KA431SLMF2TF](#) [KA431SMF2TF](#) [KA431SMFTF](#) [LM4041C12ILPR](#) [LM4120AIM5-2.5/NOP](#)
[LM431SCCMFX](#) [TS3330AQPR](#) [LM285BXXMX-1.2/NOPB](#) [LM385BM-2.5/NOPB](#) [LM4040BIM3-4.1](#) [LM4040CIM3-10.0](#) [LM4040CIM3X-2.0/NOPB](#) [LM4041BSD-122GT3](#) [LM4041QDIM3-ADJ/NO](#) [LM4050QAEM3X4.1/NOPB](#) [LM4051BIM3-ADJ/NOPB](#) [LM4051CIM3X-1.2/NOPB](#) [LM4132DMF-1.8/NOPB](#) [LM4132EMF-2.0/NOPB](#) [LM4140CCMX-1.2/NOPB](#) [LM431CIM](#) [LM385M-2.5/NOPB](#) [LM4030AMF-4.096/NOPB](#) [LM4040D30ILPR](#) [LM4051CIM3X-ADJ/NOPB](#) [AP432YG-13](#) [AS431ANTR-G1](#) [AS431BZTR-E1](#) [AN431AN-ATRG1](#)
[AP431IBNTR-G1](#) [AS431ARTR-G1](#) [AS431BNTR-G1](#) [TL431AIZ](#) [AZ431AN-ATRG1](#)