



Introduction

The XR22404 evaluation board is for the Exar USB 2.0 4-Port hub in both the 28 pin SSOP and 24 pin QFN packages. This manual is intended to guide users to use various functions and configurations of the hub device. Either the 28 pin SSOP package or 24 pin QFN package EVB can be ordered as shown in Table 1. Note that there are two revisions of the PCB, Rev. 1.0 and Rev. 1.1. The Rev. 1.0 requires rework to add a 10k pull-up resistor to be added on the EXT_RST# signal as noted in the schematic. The Rev. 1.1 PCB also added I²C programming headers such that the optional EEPROM can be programmed directly on the PCB as well as an in-rush current limiting circuit on VBUS power.

Table 1: Ordering Information

Device Ordering Part Number	Evaluation Board Ordering Part Number	Device Package	Device Location
XR22404CG28-F	XR22404CG28EVB	SSOP 28	U1
XR22404CL24-F	XR22404CL24EVB	QFN 24	U2

Board Layout and Outline

Evaluation Board outline

Figure 1 shows the topography of the evaluation board. Either U1 or U2 will be installed depending upon the version of the evaluation board.

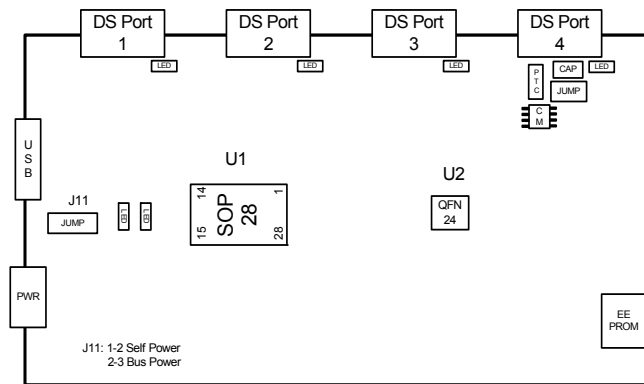
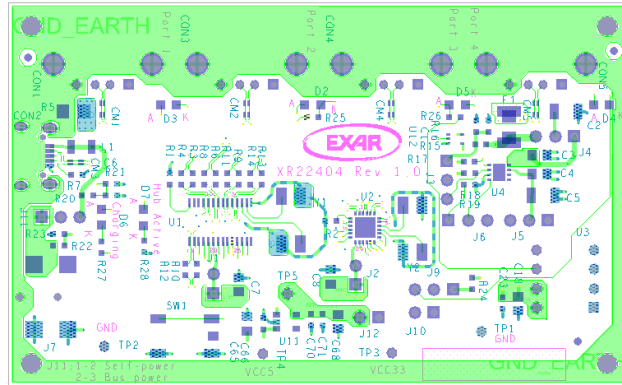

Figure 1: XR22404 PCB Outline

Evaluation Board Layout



Evaluation Board Picture

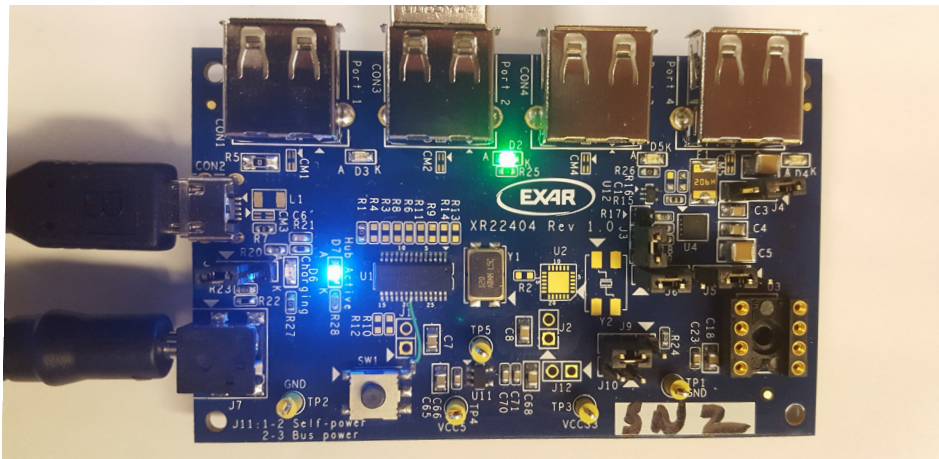

Figure 2: XR22404 PCB

Hardware Configuration

This section describes the default board settings, when shipped from the factory, and jumper settings that may be used to reconfigure operation.

Differences between XR22404CG28EVB and XR22404CL24EVB

The XR22404 is available in two packages, a 28 pin SSOP and a 24 pin QFN. The two versions of the evaluation board may use the same bare PCB, but with different components assembled, which includes either the 28 or 24 pin package. In order to avoid trace stubs on high speed USB (480 MHz) nets, 0 ohm resistors are installed from the upstream and all four downstream USB ports to connect to the QFN24 device for the XR22404CL24EVB. These resistors are not installed for the SSOP28 EVB.

Power Configurations

The XR22404 EVB may operate in either bus powered or self-powered modes. The power mode must be selected by jumper J11. If self-powered, the device uses the 5V supplied by the external 5V DC input to J11 power jack. When bus powered, the XR22404 may not be capable of providing sufficient power to all downstream ports. By USB specification each downstream port may draw 100 mA maximum and the hub itself may draw an additional 100 mA when bus powered.

The XR22404 EVB has global power monitoring and ganged power control. All four downstream ports power is combined and monitored by a single monitor circuit. Power to the downstream ports of the XR22404 EVB is monitored by a resettable PTC fuse, by an XRP2527 USB power monitor, or by both the fuse and the power monitor devices. Over-current conditions detected by either XRP2527 current monitors or PTC fuses are signaled to the OVC# pin of the device, and power out pins (PWR#) are deasserted to then power down all downstream ports. The PTC fuse has a current trip of ~2A at ambient temperature of ~21 deg. C, and the XRP2527 current monitor has a current trip of ~1.1A.

The XR22404 EVB may be also be used to charge downstream devices only when the XR22404 is self-powered. Downstream ports may be used as Charging Downstream Ports (CDPs) when the USB host is connected. In this mode, ports may also be used in normal hub operation to connect peripheral devices. When the USB host is not connected, downstream ports may be used for charging as Dedicated Charging Ports (DCPs). In this mode ports may not be used for normal hub operation when connecting peripheral devices.

Table 2 defines the jumper settings on the XR22404 EVB, the default settings and settings required to enable charging mode.

Table 2: Jumper Settings and components for PCB Power

Jumper	Description	Default
J11	J11 must be installed either pin 1-2 when the XR22404 is self-powered or pin 2-3 when the device is bus powered.	By default J11 is installed pin 2-3 for bus powered mode. For battery charging, must be installed pin 1-2.
J12	To power the device from 3.3V instead of 5V, the top surface trace across jumper J1 for the XR22404CG28EVB or J2 for the XR22404-CL24EVB should be cut and J12 may then be installed. NOTE: Damage to the XR22404 device may occur if J12 is installed without removing 5V power to the device from J1 or J2.	J12 is not installed by default.
J3, J4	J3 and J4 are used to select whether the PTC fuse only or current monitor (XRP2527) device is used for downstream port over-current protection.	By default J3 is installed from pin 2-3 and J4 is installed pin 1-2 for XRP2527 over-current monitor protection. Default settings may also be used for battery charging.
J5	If J3 is installed pin 2-3, J5 selects whether XRP2527 over-current monitor only (J5 pin 2-3) or PTC fuse and current monitor device (J5 pin 1-2) protects downstream ports.	By default, J5 is installed pin 2-3 for XRP2527 over-current monitor only. Default setting may also be used for battery charging.
J6	When J6 is installed from pin 2-3, the XRP2527 current monitors use USB 2.0 default trip voltage. If installed pin 1-2, the current monitors trip at the value established by the resistance of the RSET pin to ground using formula $ILIM (trip\ current) = \sim 108.7 / RSET\ resistance\ (kOhms)$.	By default, J6 is installed pin 2-3. Default setting may also be used for battery charging.
J9	J9 selects normal hub operation port and hub activity indicators or charging mode.	By default J9 is installed pin 2-3 for normal hub operation and LED activity indicators. Must be installed pin 1-2 to enable charging mode.

Uninstalled components on XR22404CG28EVB and XR22404CL24EVB

Both XR22404 EVBs have a number of components that are not installed. These components have a variety of purposes and some may be installed after cutting the surface “shorting traces” which short across the pins of the devices when they are not installed.

Table 3: Uninstalled Components

Uninstalled Components	
J1 & J2	By default are not installed. For power measurements, an ammeter may be installed by cutting either the surface trace on J1 (when using the SSOP28 device) or J2 (when using the QFN24 device). J1 or J2 can then be installed or an ammeter in series can be used for power measurements.
CM1 - CM5	Common Mode chokes on upstream and 4 downstream ports for EMI purposes.
R3, R4, R6, R8 - R14	Not installed on XR22404CG28EVB to prevent stubs on high speed USB traces.
C1, R16	Test purposes only.
Y1 / Y2 and R1 / R2	For the XR22404CG28EVB Y2 and R2 are not installed. For the XR22404CL24EVB Y1 and R1 are not installed.

LED Indicators

Each USB port of the XR22404 EVBs has green activity indicators. The upstream port has a single blue LED to indicate any hub activity. The LED is lit when the hub is connected to a USB host. However, if there are no downstream ports connected, following device enumeration and a short period of inactivity, the hub will be placed in suspend state and the hub activity LED will not be lit. The 4 downstream ports have green LEDs for port activity.

EEPROM

As documented in the XR22404 datasheet, an EEPROM can be used to configure the hub descriptors reported to the USB host.

XR22404 Evaluation Board Bill of Materials

The Bill of Materials for the two versions of the XR22404 evaluation boards are in the following tables. The XR22404-CL24EVB BOM is in Table 4 and XR22404CG28EVB in Table 5. Several component part numbers marked "DNI" may typically be not installed on the Exar evaluation boards. However, these may be used on customer PCBs for EMI or other purposes as desired.

Table 4: XR22404CG28EVB BOM (Rev. 1.0 PCB)

Item	Qty	Ref. Des	Description	Part Number
1	5	CM1, CM2, CM3, CM4, CM5	Common Mode Choke Surface Mount	744230900_DNI
2	4	CON1, CON3, CON4, CON5	USB Conn, Receptable, A-type	61400416021
3	1	CON2	Connector, USB_MICRO_ B	885012107014
4	1	C1	Ceramic Capacitor, 10nF/25V 0603	885012206065_DNI
5	2	C2, C5	Ceramic Capacitor, 47uF/16V 1210	885012109011
6	4	C3, C4, C65, C68	Ceramic Capacitor, 1uF/16V, 0805	885012207051
7	8	C6, C19, C21, C22, C23, C66, C70, C71	Ceramic Capacitor, 100nF/25V 0603	885012206071
8	2	C7, C18	Ceramic Capacitor, 10uF/16V 0805	885012107014
9	4	D2, D3, D4, D5	LED, Green, 0805	150080GS75000
10	1	D7	LED, Blue, 0805	150080BS75000
11	1	F1	PTC Resettable, 2A 8V 1812	MF-MSMF200-2
12				
13	6	J3, J4, J5, J6, J9, J11	3 Positions Header, 0.100" (2.54mm)	61300311121
14	2	J1, J2, J10	2 Positions Header, 0.100" (2.54mm)	61300211121_DNI
15	1	J7	Connector, Power Jack, DC RA SMD	694103107102
16	1	L1	Ferrite Bead, 2.5A 600 Ohm 1206 Surface Mount	74279221601
17	3	R1, R25, R26	Resistor, 2.7 kOhm, 1%, 0603	
18	2	R5, R15	Resistor, 0 Ohm, 0603	
19	11	R3, R4, R6, R7, R8, R9, R10, R11, R12, R13, R14	Resistor, 0 Ohm, 0603	DNI
20	1	R16	Resistor, 100 kOhm, 5%, 0603	DNI
21	5	R17, R18, R20, R23, R24	Resistor, 10 kOhm, 5%, 0603	
22	2	R19, R21	Resistor, 100 kOhm, 5%, 0603	
23	1	R22	Resistor, 5.1 kOhm, 5%, 0603	
24	1	R28	Resistor, 470 Ohm, 5%, 0603	
25	1	SW1	Switch, SPST-NO	431481031816
26	5	TP1, TP2, TP3, TP4, TP5	Test Point PC Mini .040"D Yellow	36-5004-ND
27	1	U1	IC, USB 2.0 Hub, 4 Port	XR22404CG28-F
28	1	U3	IC EEPROM 2KBIT 400KHZ 8DIP	24LC02B/P

Table 4: XR22404CG28EVB BOM (Rev. 1.0 PCB)

Item	Qty	Ref. Des	Description	Part Number
29	1	U4	USB Current Monitor, DFN8 2x3	XRP2527IHB-1-F
30	1	U11	LDO 5V to 3.3V	SP6260GEK-L/TR_DNI
31	1	U12	Inverter IC 1 Channel Schmitt Trigger SC-70	M74VHC1GT14DFT1G
32	1	Y1	12MHz \pm 20ppm Crystal 18pF -20°C ~ 70°C 4-SMD	ABMM-12.000MHZ-B2-T

Note: Part numbers marked _DNI are not installed.

Table 5: XR22404CL24EVB BOM (Rev. 1.1 PCB)

Item	Qty	Ref. Des	Description	Part Number
1	5	CM1, CM2, CM3, CM4, CM5	Common Mode Choke Surface Mount	744230900_DNI
2	4	CON1, CON3, CON4, CON5	USB Conn, Receptable, A-type	61400416021
3	1	CON2	Connector, USB_MICRO_ B	885012107014
4	1	C1	Ceramic Capacitor, 10nF/25V 0603	885012206065_DNI
5	3	C2, C5, C73	Ceramic Capacitor, 47uF/16V 1210	885012109011
6	4	C3, C4, C65, C68	Ceramic Capacitor, 1uF/16V, 0805	885012207051
7	9	C6, C19, C21, C22, C23, C66, C70, C71, C72	Ceramic Capacitor, 100nF/25V 0603	885012206071
8	1	C18	Ceramic Capacitor, 10uF/16V 0805	885012107014
9	4	D2, D3, D4, D5	LED, Green, 0805	150080GS75000
10	1	D7	LED, Blue, 0805	150080BS75000
11	1	F1	PTC Resettable, 2A 8V 1812	MF-MSMF200-2
12	6	J1, J2, J12, J13, J15, J17	2 Positions Header, 0.100" (2.54mm)	61300211121
13	7	J3, J4, J5, J6, J9, J11, J16	3 Positions Header, 0.100" (2.54mm)	61300311121
15	1	J7	Connector, Power Jack, DC RA SMD	694103107102
16	1	Q1	MOSFET P-Ch 12V 4.1A SOT23-3	SI2333DS-T1-E3
17	1	R30	Resistor, 40.2 kOhm, 5%, 0603	
18	4	R2, R25, R26	Resistor, 2.7 kOhm, 1%, 0603	
19	12	R3, R4, R5, R6, R8, R9, R10, R11, R12, R13, R14, R15	Resistor, 0 Ohm, 0603	
20	1	R7	Resistor, 0 Ohm, 0603	DNI
21	1	R16	Resistor, 100 kOhm, 5%, 0603	DNI
22	6	R17, R18, R20, R23, R24, R29	Resistor, 10 kOhm, 5%, 0603	
23	2	R19, R21	Resistor, 100 kOhm, 5%, 0603	
24	1	R22	Resistor, 5.1 kOhm, 5%, 0603	
25	1	R28	Resistor, 470 Ohm, 5%, 0603	

Table 5: XR22404CL24EVB BOM (Rev. 1.1 PCB)

Item	Qty	Ref. Des	Description	Part Number
26	1	SW1	Switch, SPST-NO	431481031816
27	5	TP1, TP2, TP3, TP4, TP5	Test Point PC Mini .040"D Yellow	36-5004-ND
28	1	U2	IC, USB 2.0 Hub, 4 Port	XR22404CL24-F
29	1	U3	IC EEPROM 2KBIT 400KHZ 8DIP	24LC02B/P
30	1	U4	USB Current Monitor, DFN8 2x3	XRP2527IHB-1-F
31	1	U11	LDO 5V to 3.3V	SP6260GEK-L/TR_DNI
32	1	U12	Inverter IC 1 Channel Schmitt Trigger SC-70	M74VHC1GT14DFT1G
33	1	Y2	12MHz \pm 20ppm Crystal 18pF -20°C ~ 70°C 4-SMD	ABMM-12.000MHZ-B2-T

Note: Part numbers marked _DNI are not installed.

Revision History

Revision	Date	Description
1A	August 2016	Initial release

For Further Assistance:

Email: UARTtechsupport@exar.com

Exar Technical Documentation: <http://www.exar.com/techdoc/>

Exar Corporation Headquarters and Sales Offices
48720 Kato Road Tel: +1 (510) 668-7000
Fremont, CA 95438 - USA Fax: +1 (510) 668-7001



NOTICE

EXAR Corporation reserves the right to make changes to the products contained in this publication in order to improve design, performance or reliability. EXAR Corporation assumes no responsibility for the use of any circuits described herein, conveys no license under any patent or other right, and makes no representation that the circuits are free of patent infringement. Charts and schedules contained herein are only for illustration purposes and may vary depending upon a user's specific application. While the information in this publication has been carefully checked; no responsibility, however, is assumed for inaccuracies.

EXAR Corporation does not recommend the use of any of its products in life support applications where the failure or malfunction of the product can reasonably be expected to cause failure of the life support system or to significantly affect its safety or effectiveness. Products are not authorized for use in such applications unless EXAR Corporation receives, in writing, assurances to its satisfaction that: (a) the risk of injury or damage has been minimized; (b) the user assumes all such risks; (c) potential liability of EXAR Corporation is adequately protected under the circumstances.

Reproduction, in part or whole, without the prior written consent of EXAR Corporation is prohibited.

X-ON Electronics

Largest Supplier of Electrical and Electronic Components

Click to view similar products for [Interface Development Tools](#) category:

Click to view products by [MaxLinear](#) manufacturer:

Other Similar products are found below :

[ADP5585CP-EVALZ](#) [CHA2066-99F](#) [AS8650-DB](#) [416100120-3](#) [XR18910ILEVB](#) [XR21B1421IL28-0A-EVB](#) [EVAL-ADM2491EEBZ](#)
[MAXREFDES23DB#](#) [MAX13235EEVKIT](#) [DFR0257](#) [XR22404CG28EVB](#) [ZLR964122L](#) [ZLR88822L](#) [DC327A](#) [PIM511](#) [PIM536](#) [PIM517](#)
[DEV-17512](#) [STR-FUSB3307MPX-PPS-GEVK](#) [ZSSC3240KIT](#) [P0551](#) [MAX9121EVKIT](#) [PIM532](#) [ZSC31010KITV2P1](#) [UMFT4233HPEV](#)
[MIKROE-2335](#) [XR20M1172G28-0B-EB](#) [SI871XSOIC8-KIT](#) [1764](#) [1833](#) [1862](#) [EVB-USB82514](#) [ATA6628-EK](#) [EVAL-CN0313-SDPZ](#) [2264](#)
[MCP23X17EV](#) [PS081-EVA-HR MODULE](#) [237](#) [SMA2RJ45EVK/NOPB](#) [FR12-0002](#) [MAFR-000455-001](#) [BOB-13263](#) [ORG4572-R01-UAR](#)
[CPC5622-EVAL-600R](#) [SKYFR-000743](#) [SKYFR-000827](#) [SKYFR-000982](#) [MIKROE-2750](#) [292](#) [DFR0065](#)