

Description

The [XR33180](#), [XR33181](#), [XR33183](#) and [XR33184](#) are high performance RS-485/RS-422 receivers designed to meet the increasing system requirements found in today's high performance serial communication applications.

The receiver includes enhanced failsafe circuitry, guaranteeing a logic-high receiver output when the receiver inputs are open, shorted, or undriven. The XR33180/81/83/84 (XR3318x) receiver input impedance is at least $48\text{k}\Omega$ (1/4 unit load), allowing more than 128 devices on the bus. The bus pins are ESD protected and pass IEC61000 level 4 ($\pm 15\text{kV}$).

This is a wide supply (3.0V to 5.5V) device that operates at a maximum data rate of 52Mbps and comes in very small 5-pin and 6-pin TSOT23 packages, making this standalone receiver ideal for high speed point-to-point RS-485 applications where space is a concern.

The XR3318x offers several pinout options to maximize performance in different applications while maintaining a minimum pin count. The XR33180 is available in a 5-pin TSOT23 package with the receiver always enabled. The XR33181 is available in a 6-pin TSOT23 package and offers a active high receiver enable pin while the XR33183 has the same pinout but with active low enable pin. The XR33184 is available in a 6-pin TSOT23 package with a I/O logic supply pin to ease the interface to MCU's or FPGA's that run off of different supply voltages. The V_L supply pin allows the XR33184 to interface to other devices running off of supplies from ranging from 1.65V to V_{CC} .

All XR3318x options operate up to a max data rate of 52Mbps, and have excellent propagation delay and skew characteristics making them a good choice for clock fanout or clock distribution systems.

Typical Application

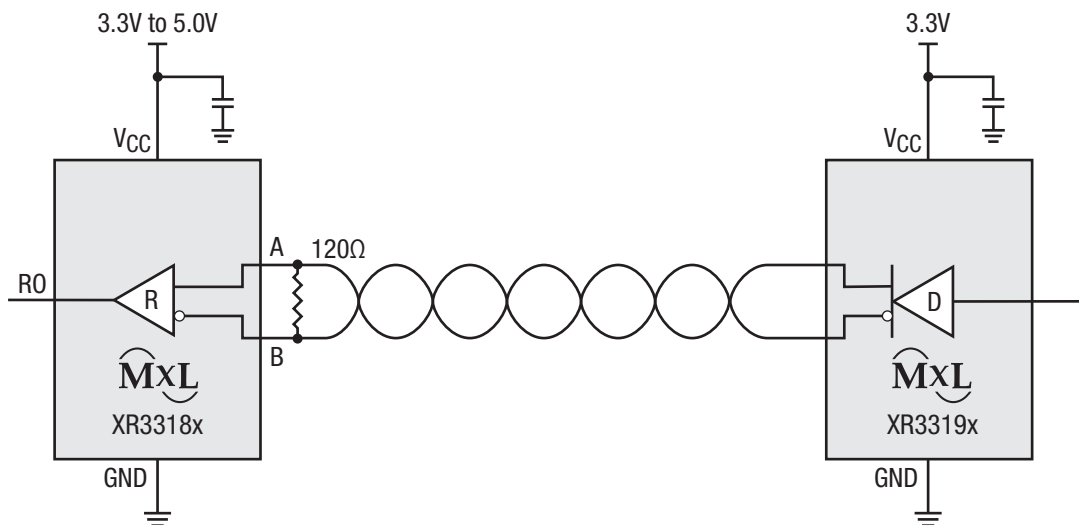

Figure 1. Typical Application

FEATURES

- Max 52Mbps data rate
- Wide 3.0V to 5.5V supply operation
- Robust Electrostatic Discharge (ESD) protection for RS-485 bus pins
 - $\pm 15\text{kV}$ human body model
 - $\pm 15\text{kV}$ IEC61000-4-2 air discharge
 - $\pm 8\text{kV}$ IEC61000-4-2 contact discharge
- Enhanced receiver failsafe protection for open, shorted, or terminated but idle data lines
- -40°C to 125°C ambient operating temperature range
- Lead-free (RoHS 6) TSOT23-5 and TSOT23-6 packaging
- Absolute minimum pin count option, XR33180 (5-pin TSOT23)
- Tri-state RO options, XR33181 and XR33183
- Adjustable I/O supply option to help interfacing to lower voltage logic, XR33184

APPLICATIONS

- Clock distribution
- Robotic control
- Space constrained systems
- Security camera networks
- Industrial and process control equipment

Absolute Maximum Ratings

Stresses beyond those listed under Absolute Maximum Ratings may cause permanent damage to the device. Exposure to any Maximum Rating condition for extended periods may affect device reliability and lifetime.

Supply voltage (V_{CC}) -0.3V to 7.0V

Junction temperature 150°C

Input Voltages

EN and \overline{EN} -0.3V to 7.0V

Output Voltage

RO (XR33180/81/83) -0.3V to ($V_{CC} + 0.3V$)

RO (XR33184) -0.3V to ($V_L + 0.3V$)

Receiver Input Voltages

A, B $\pm 18V$

Transient voltage pulse, through $100\Omega^{(1)}$ $\pm 100V$

ESD Ratings

HBM - Human Body Model (A and B pins) $\pm 15kV$

HBM - Human Body Model (all other pins) $\pm 4kV$

IEC61000-4-2 Air Gap Discharge $\pm 15kV$

IEC61000-4-2 Contact Discharge $\pm 8kV$

NOTE:

1. Refer to Figure 3.

Operating Conditions

Operating temperature range -40°C to 125°C

V_{CC} supply range 3.0V to 5.5V

Thermal Information

5-pin TSOT23 θ_{JA} 185.5°C/W

5-pin TSOT23 θ_{JC} 61.6°C/W

6-pin TSOT23 θ_{JA} 167.3°C/W

6-pin TSOT23 θ_{JC} 61.6°C/W

Electrical Characteristics

Specifications are at $T_A = 25^\circ C$, $V_{CC} = 3.0V$ to $5.5V$ unless otherwise noted. Typical values represent the most likely parametric norm at $T_A = 25^\circ C$, and are provided for reference purposes only.

Symbol	Parameter	Conditions	Min	Typ	Max	Units
Supply						
V_{CC}	Supply voltage range		3.0		5.5	V
V_L	I/O supply voltage range	$V_L \leq V_{CC}$	1.65		V_{CC}	V
I_{CC}	Supply current	No Load, XR33180/81/83/84		2.5	5	mA
I_L	I/O supply	No Load, XR33184			10	μA
Receiver DC Characteristics						
V_{TH}	Receiver differential threshold voltage, $V_A - V_B$	$-7V \leq V_{CM} \leq 12V$	-200	-125	-50	mV
ΔV_{OH}	Receiver input hysteresis	$V_{CM} = 0V$		25		mV
R_{IN}	Receiver input resistance	$-7V \leq V_{CM} \leq 12V$	48			k Ω
$I_{A,B}$	Input current, A and B	$V_{OUT} = 12V, V_{CC} = 0V$ or $5.5V$			250	μA
		$V_{OUT} = -7V, V_{CC} = 0V$ or $5.5V$	-200			μA

Electrical Characteristics

Specifications are at $T_A = 25^\circ\text{C}$, $V_{CC} = 3.0\text{V}$ to 5.5V unless otherwise noted. Typical values represent the most likely parametric norm at $T_A = 25^\circ\text{C}$, and are provided for reference purposes only.

Symbol	Parameter	Conditions	Min	Typ	Max	Units
Logic Inputs/Outputs						
V_{IH}	Logic high input thresholds, EN and \overline{EN}	XR33181/83	2			V
V_{IL}	Logic low input thresholds, EN and \overline{EN}	XR33181/83			0.4	V
I_{ENLEAK}	Enable pin leakage	XR33181/83	-10		10	μA
V_{OH}	Receiver output high voltage, RO	$I_{OUT} = -4\text{mA}$, XR33180/81/83	$V_{CC} - 0.4$			V
V_{OL}	Receiver output low voltage, RO	$I_{OUT} = 4\text{mA}$, XR33180/81/83			0.4	V
V_{OH}	Receiver output high voltage, RO	$3.0\text{V} \leq V_L \leq 5.5\text{V}$, $I_{OUT} = -4\text{mA}$ $1.65\text{V} \leq V_L \leq 3.0\text{V}$, $I_{OUT} = -1\text{mA}$, XR33184	$V_L - 0.4$			V
V_{OL}	Receiver output low voltage, RO	$3.0\text{V} \leq V_L \leq 5.5\text{V}$, $I_{OUT} = 4\text{mA}$ $1.65\text{V} \leq V_L \leq 3.0\text{V}$, $I_{OUT} = 1\text{mA}$, XR33184			0.4	V
I_{OSC}	Receiver output short-circuit current	$0\text{V} \leq V_{RO} \leq V_L$	-120		120	mA
I_{OZR}	High-Z receiver output current	$0\text{V} \leq V_{OUT} \leq V_{CC}$, XR33180/81/83 $0\text{V} \leq V_{OUT} \leq V_L$, XR33184	-1		1	μA
Thermal Characteristics						
T_{TS}	Thermal shutdown temperature			168		$^\circ\text{C}$
T_{TSH}	Thermal shutdown hysteresis			15		$^\circ\text{C}$
Receiver AC Characteristics						
t_{RPLH}	Receiver propagation delay, low to high	$C_L = 15\text{pF}$, $V_{ID} = \pm 2\text{V}$, V_{ID} rise and fall times $< 15\text{ns}$, Figure 4			15	ns
t_{RPHL}	Receiver propagation delay, high to low				15	ns
$ t_{RPLH} - t_{RPHL} $	Receiver propagation delay skew				2	ns
	Propagation delay matching, device to device ⁽¹⁾	Part to part comparisons must have the same supply conditions and temperature difference $\leq 30^\circ\text{C}$ (max)			8	ns
	Maximum data rate ⁽¹⁾	$C_L = 15\text{pF}$, Duty Cycle 40 to 60%	52			Mbps
t_{RZH}	Receiver enable to output high	$C_L = 15\text{pF}$, $R_L = 1\text{K}\Omega$, Figure 5			500	ns
t_{RZL}	Receiver enable to output low				500	ns
t_{RHZ}	Receiver disable from output high				500	ns
t_{RLZ}	Receiver disable from output low				500	ns

NOTE:

1. Guaranteed by design.

Pin Configuration

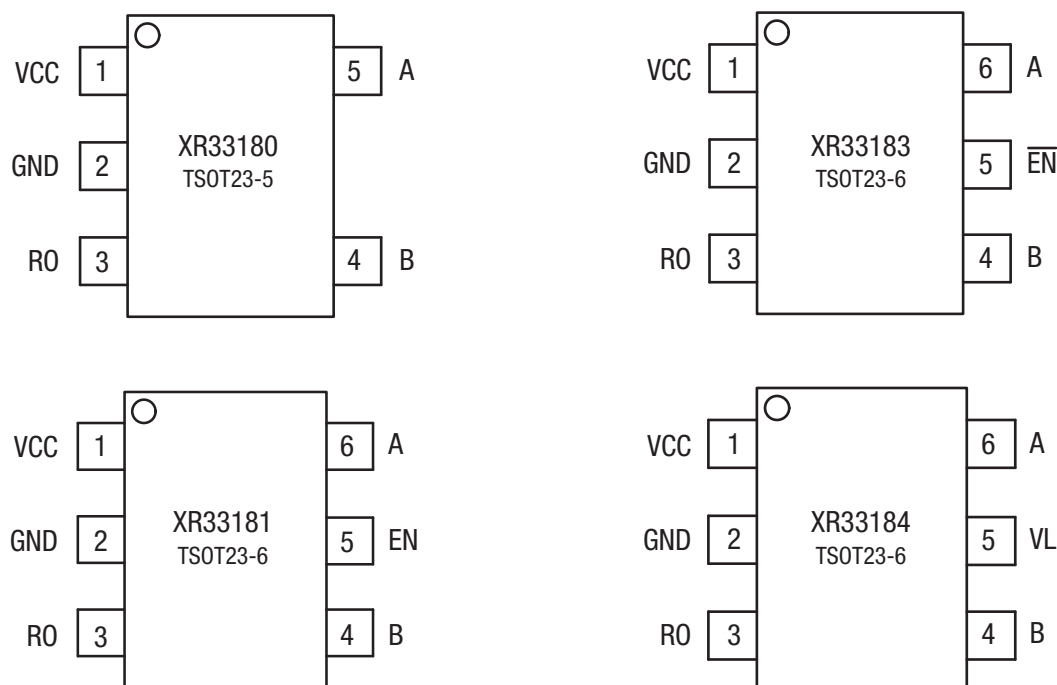

Pin Functions

Pin Number				Pin Name	Type	Description
XR33180	XR33181	XR33183	XR33184			
1	1	1	1	VCC	Supply	Power supply, bypass with 0.1 μ f capacitor
2	2	2	2	GND	Supply	Ground
3	3	3	3	RO	Output	Receiver output: if $(V_A - V_B) \geq -50\text{mV}$, RO is high if $(V_A - V_B) \leq -200\text{mV}$, RO is low
4	4	4	4	B	Bus Input	$\pm 15\text{KV}$ ESD protected, RS-485/RS-422 inverting receiver input
-	5	-	-	EN	Input	Receiver output enable: when EN is low, RO is disabled, high impedance when EN is high, RO is enabled
-	-	5	-	$\overline{\text{EN}}$	Input	Receiver output enable: when $\overline{\text{EN}}$ is high, RO is disabled, high impedance when $\overline{\text{EN}}$ is low, RO is enabled
-	-	-	5	VL	Supply	Logic interface power supply
5	6	6	6	A	Bus Input	$\pm 15\text{KV}$ ESD protected, RS-485/RS-422 non-inverting receiver input

Pin Functions (Continued)

Receiving		
Inputs		Output
\overline{RE}	$V_A - V_B$	RO
0	$\geq -50\text{mV}$	1
0	$\leq -200\text{mV}$	0
0	Open/shorted/idle	1
1	X	High-Z

Functional Block Diagrams

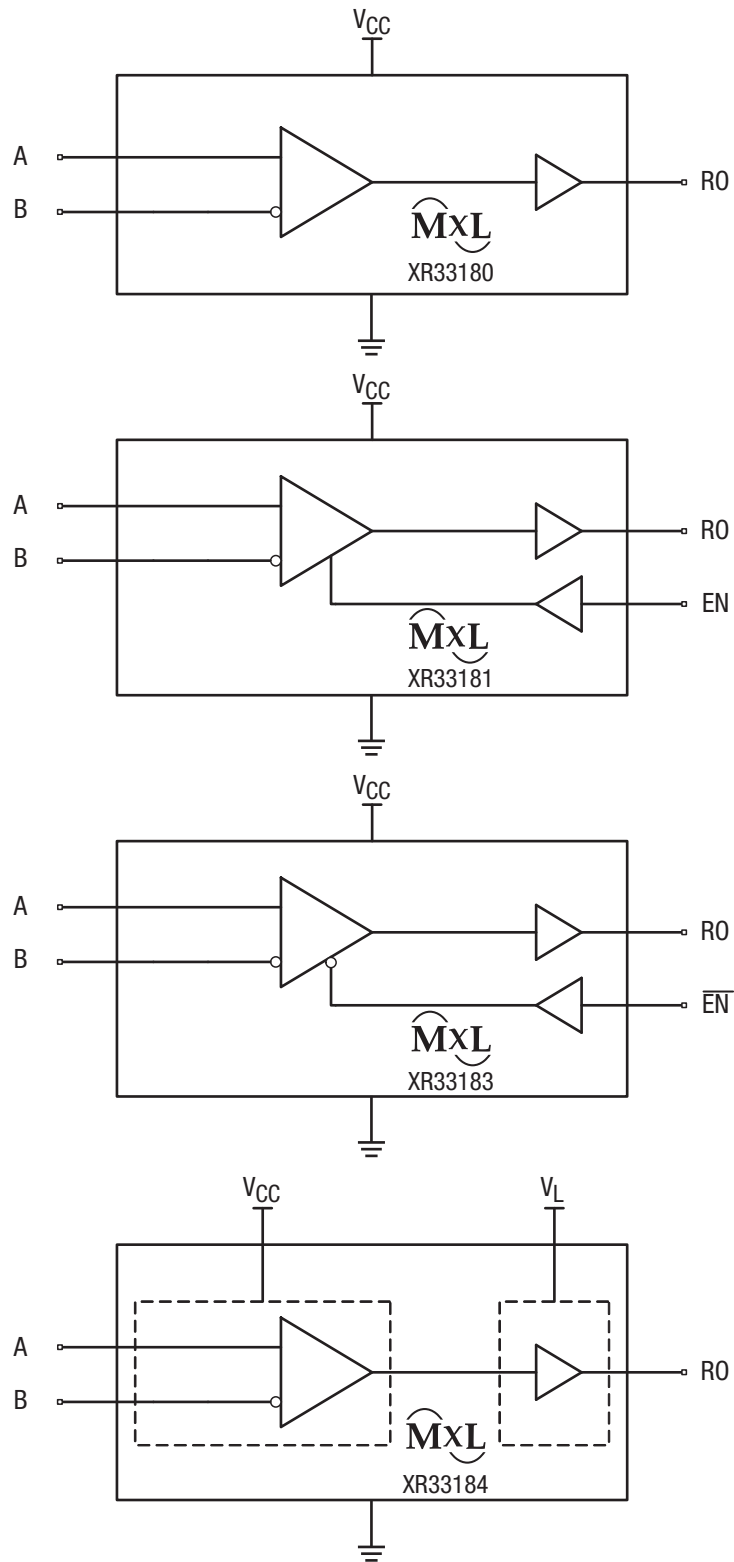

Figure 2. Functional Block Diagrams

Applications Information

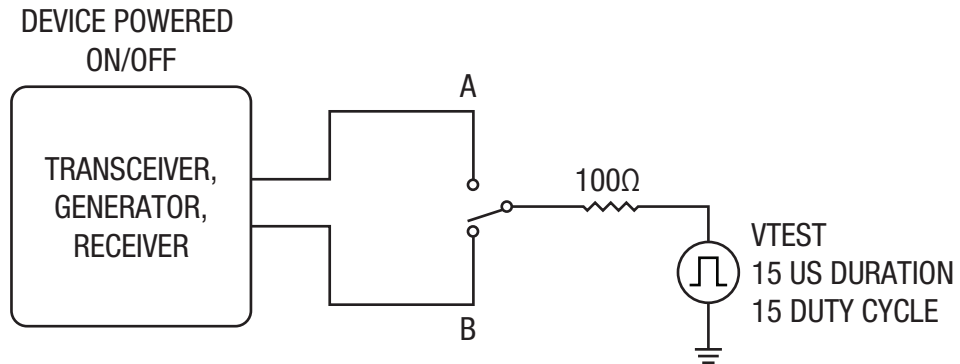

Figure 3. Transient Overvoltage Test Circuit

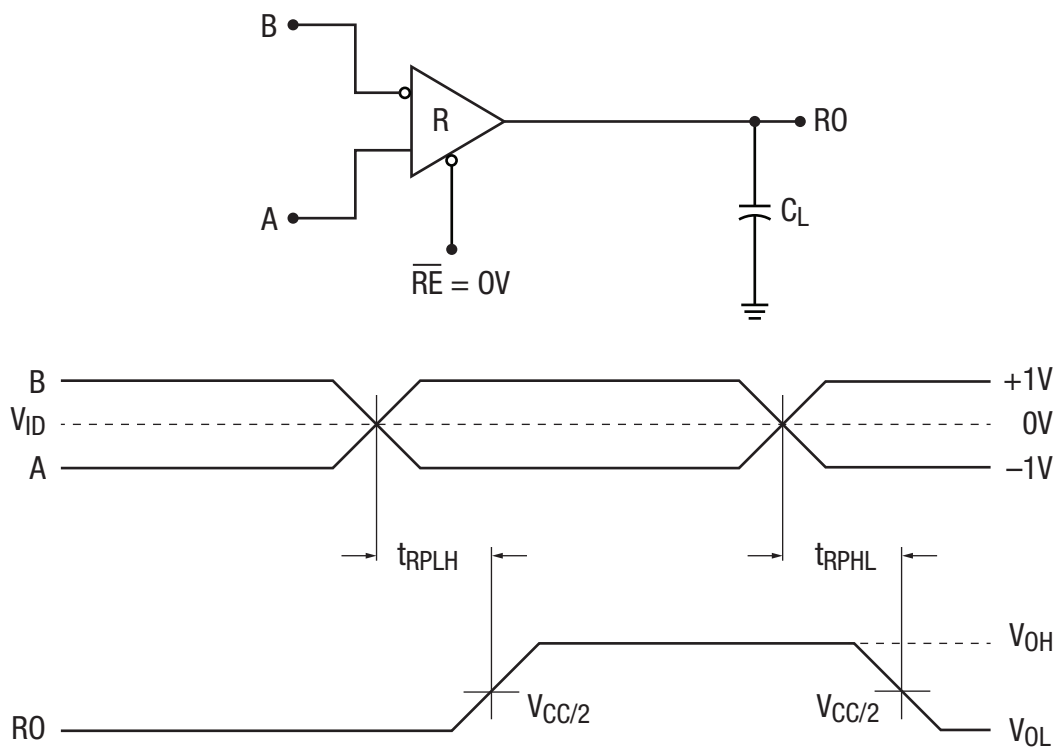

Figure 4. Receiver Propagation Delay Test Circuit and Timing Diagram

Applications Information (Continued)

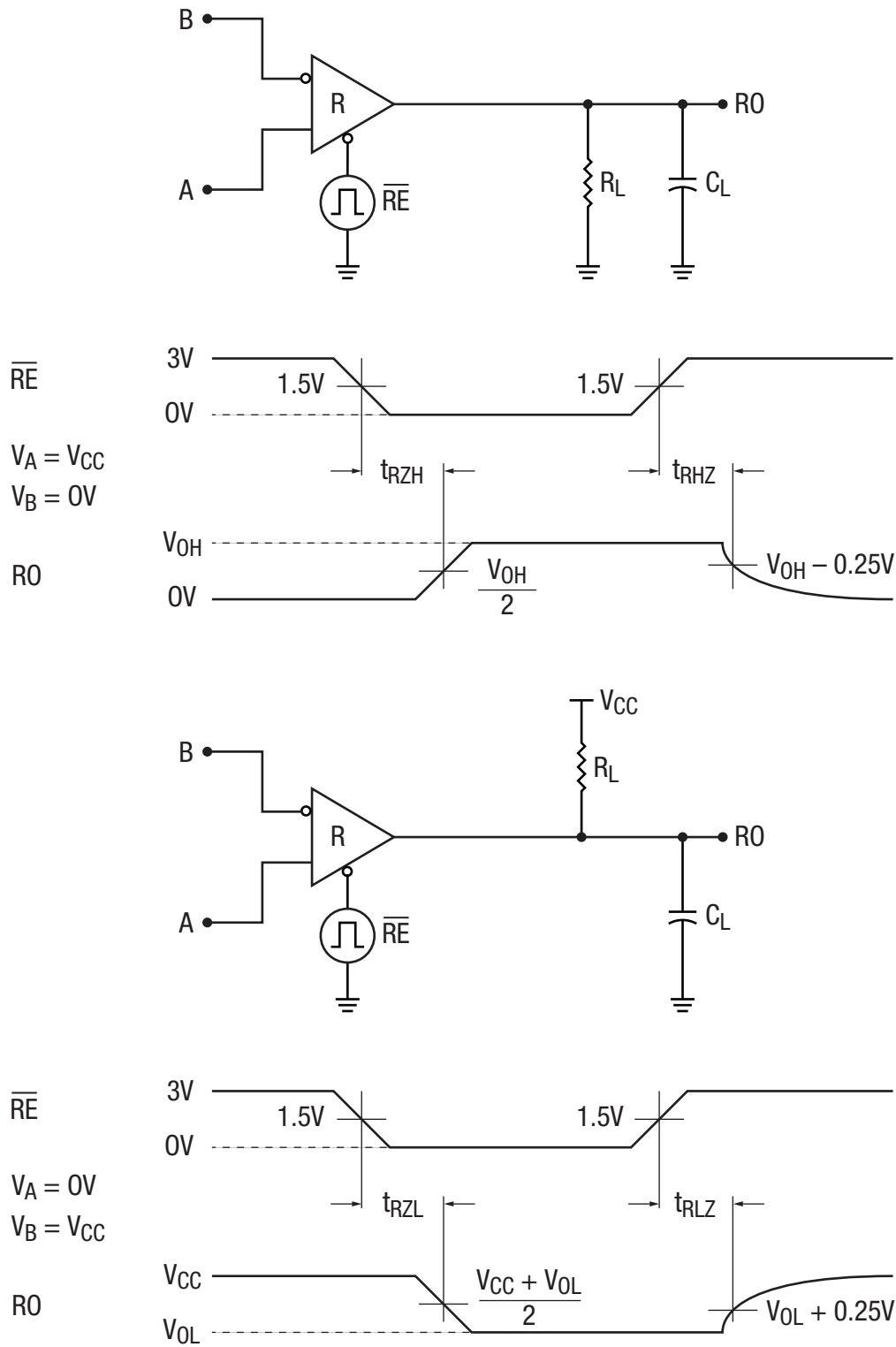

Figure 5. Receiver Enable and Disable Test Circuits and Timing Diagrams

Applications Information (Continued)

The XR3318x RS-485/RS-422 device is part of MaxLinear's high performance serial interface product line. The analog bus pins can survive direct shorts up to $\pm 18V$ and are protected against ESD events up to $\pm 15kV$.

Enhanced Failsafe

Ordinary RS-485 differential receivers will be in an indeterminate state whenever the data bus is not being actively driven. The enhanced failsafe feature of the XR3318x guarantees a logic-high receiver output when the receiver inputs are open, shorted or when they are connected to a terminated transmission line with all drivers disabled. In a terminated bus with all transmitters disabled, the receivers' differential input voltage is pulled to 0V by the termination. The XR3318x interprets 0V differential as a logic high with a minimum 50mV noise margin while maintaining compliance with the RS-485 standard of $\pm 200mV$. Although the XR3318x does not need failsafe biasing resistors, it can operate without issue if biasing is used.

$\pm 15kV$ ESD Protection

ESD protection structures are incorporated on all pins to protect against electrostatic discharges encountered during handling and assembly. The receiver inputs of the XR3318x have extra protection against static electricity. MaxLinear uses state-of-the-art structures to protect these pins against ESD of $\pm 15kV$ without damage. The ESD structures withstand high ESD in all states: normal operation and powered down. After an ESD event, the XR3318x keeps operating without latch-up or damage.

ESD protection can be tested in various ways. The receiver inputs of the XR3318x are characterized for protection to the following limits:

- $\pm 15kV$ HBM (Human Body Model), bus pins
- $\pm 15kV$ IEC 61000-4-2 air discharge, bus pins
- $\pm 8kV$ IEC 61000-4-2 contact discharge, bus pins
- $\pm 4kV$ using the Human Body Model, all other pins

ESD Test Conditions

ESD performance depends on a variety of conditions. Contact MaxLinear for a reliability report that documents test setup, methodology and results.

Maximum Number of Receivers on the Bus

The standard RS-485 receiver input impedance is $12k\Omega$ (1 unit load). A standard driver can drive up to 32 unit loads. The XR3318x receiver has a 1/4th unit load receiver input impedance of $48K\Omega$, allowing up to 128 receivers to be connected in parallel on a communication line. Any combination of the XR33180/81/83/84's and other RS-485 receivers up to a total of 32 unit loads may be connected to the line.

Product Selector Guide

Part Number	Data Rate	Receiver Enable	Nodes On Bus	V_L Pin	Package
XR33180	52Mbps	No	128	No	5-pin TSOT23
XR33181		Yes (active high)		No	6-pin TSOT23
XR33183		Yes (active low)		No	
XR33184		No		Yes	

Mechanical Dimensions

5-Pin TSOT23

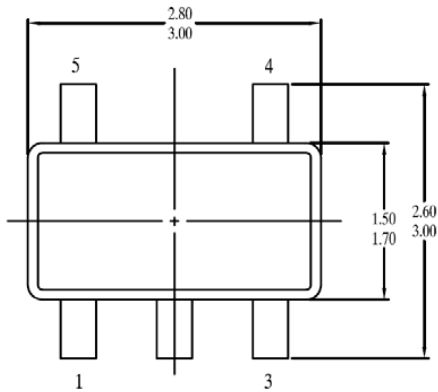

TOP VIEW

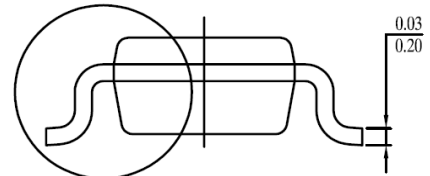

SEE DETAIL "A"

SIDE VIEW-1

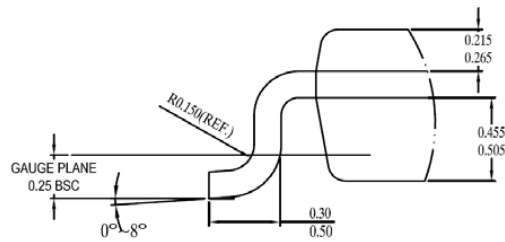

DETAIL "A"

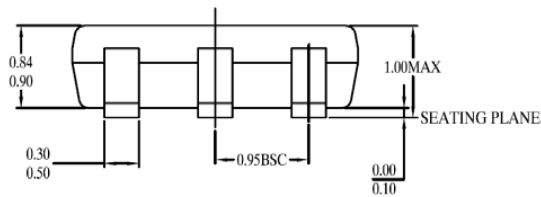

SIDE VIEW - 2

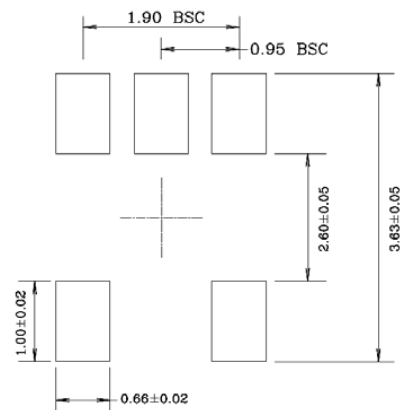

TYPICAL RECOMMENDED LAND PATTERN

1. All dimensions are in Millimeters
2. Dimensions and tolerance per Jeduc MO-193

Drawing No. : POD - 00000076

Revision: A.1

Mechanical Dimensions (Continued)

6-Pin TSOT23

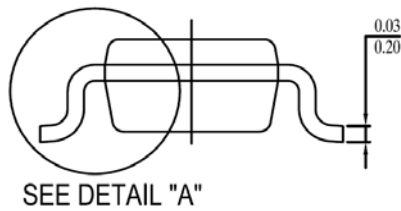
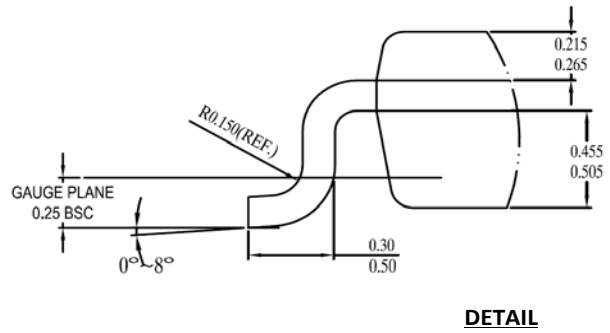
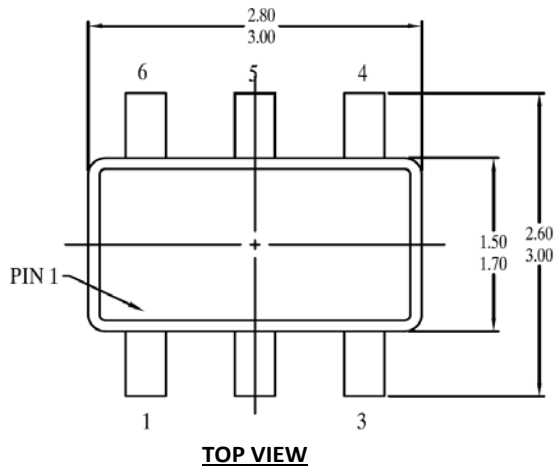

SIDE VIEW-1

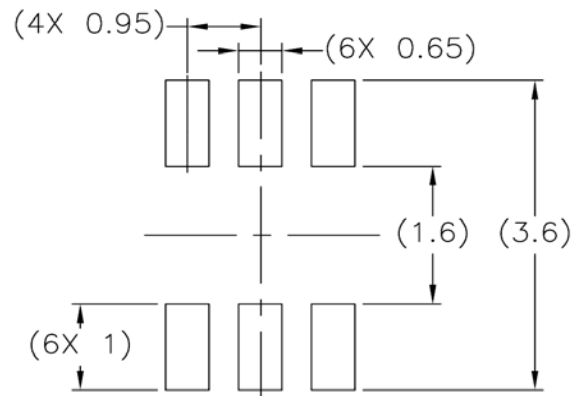
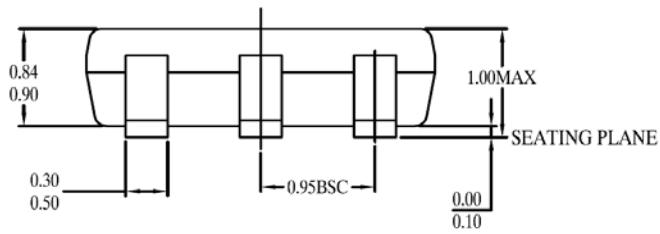

1. All dimensions are in Millimeters
2. Dimensions and tolerance per Jedec MO-193

Drawing No. : POD - 0000077

Revision: A.1

Ordering Information⁽¹⁾

Part Number	Additional Feature	Operating Temperature Range	Lead-Free	Package	Packaging Method
XR33180ESBTR	-	-40°C to 125°C	Yes ⁽²⁾	5-pin TSOT23	Tape and Reel
XR33181ESBTR	Active High Enable			6-pin TSOT23	
XR33183ESBTR	Active Low Enable				
XR33184ESBTR	Logic Level Supply, V _L				
XR33180ESBEVB	Evaluation Board				
XR33181ESBEVB					
XR33183ESBEVB					
XR33184ESBEVB					

NOTE:

1. Refer to www.exar.com/XR33180, www.exar.com/XR33181, www.exar.com/XR33183, www.exar.com/XR33184 for most up-to-date Ordering Information.
2. Visit www.exar.com for additional information on Environmental Rating.

Revision History

Revision	Date	Description
1A	June 2016	Initial Release
1B	August 2016	Update tape and reel quantity in Ordering Information table
1C	February 2018	Update to MaxLinear logo. Update format and Ordering Information format. Moved ESD ratings to page 2.



Corporate Headquarters:
 5966 La Place Court
 Suite 100
 Carlsbad, CA 92008
 Tel.: +1 (760) 692-0711
 Fax: +1 (760) 444-8598
www.maxlinear.com

High Performance Analog:
 1060 Rincon Circle
 San Jose, CA 95131
 Tel.: +1 (669) 265-6100
 Fax: +1 (669) 265-6101
 Email: serialtechsupport@exar.com
www.exar.com

The content of this document is furnished for informational use only, is subject to change without notice, and should not be construed as a commitment by MaxLinear, Inc.. MaxLinear, Inc. assumes no responsibility or liability for any errors or inaccuracies that may appear in the informational content contained in this guide. Complying with all applicable copyright laws is the responsibility of the user. Without limiting the rights under copyright, no part of this document may be reproduced into, stored in, or introduced into a retrieval system, or transmitted in any form or by any means (electronic, mechanical, photocopying, recording, or otherwise), or for any purpose, without the express written permission of MaxLinear, Inc.

MaxLinear, Inc. does not recommend the use of any of its products in life support applications where the failure or malfunction of the product can reasonably be expected to cause failure of the life support system or to significantly affect its safety or effectiveness. Products are not authorized for use in such applications unless MaxLinear, Inc. receives, in writing, assurances to its satisfaction that: (a) the risk of injury or damage has been minimized; (b) the user assumes all such risks; (c) potential liability of MaxLinear, Inc. is adequately protected under the circumstances.

MaxLinear, Inc. may have patents, patent applications, trademarks, copyrights, or other intellectual property rights covering subject matter in this document. Except as expressly provided in any written license agreement from MaxLinear, Inc., the furnishing of this document does not give you any license to these patents, trademarks, copyrights, or other intellectual property.

Company and product names may be registered trademarks or trademarks of the respective owners with which they are associated.

© 2016 - 2018 MaxLinear, Inc. All rights reserved

X-ON Electronics

Largest Supplier of Electrical and Electronic Components

Click to view similar products for [Interface Development Tools](#) category:

Click to view products by [MaxLinear](#) manufacturer:

Other Similar products are found below :

[ADP5585CP-EVALZ](#) [CHA2066-99F](#) [AS8650-DB](#) [416100120-3](#) [XR18910ILEVB](#) [XR21B1421IL28-0A-EVB](#) [EVAL-ADM2491EEBZ](#)
[MAXREFDES23DB#](#) [MAX13235EEVKIT](#) [DFR0257](#) [XR22404CG28EVB](#) [ZLR964122L](#) [ZLR88822L](#) [DC327A](#) [PIM511](#) [PIM536](#) [PIM517](#)
[DEV-17512](#) [STR-FUSB3307MPX-PPS-GEVK](#) [ZSSC3240KIT](#) [P0551](#) [MAX9121EVKIT](#) [PIM532](#) [ZSC31010KITV2P1](#) [UMFT4233HPEV](#)
[MIKROE-2335](#) [XR20M1172G28-0B-EB](#) [SI871XSOIC8-KIT](#) [1764](#) [1833](#) [1862](#) [EVB-USB82514](#) [ATA6628-EK](#) [EVAL-CN0313-SDPZ](#) [2264](#)
[MCP23X17EV](#) [PS081-EVA-HR MODULE](#) [237](#) [SMA2RJ45EVK/NOPB](#) [FR12-0002](#) [MAFR-000455-001](#) [BOB-13263](#) [ORG4572-R01-UAR](#)
[CPC5622-EVAL-600R](#) [SKYFR-000743](#) [SKYFR-000827](#) [SKYFR-000982](#) [MIKROE-2750](#) [292](#) [DFR0065](#)