



40V, 3/5/8A Synchronous Step Down COT Regulator

February 2015

Rev. 1A

GENERAL DESCRIPTION

The XR76203, XR76205 and XR76208 are synchronous step-down regulators combining the controller, drivers, bootstrap diode and MOSFETs in a single package for point-of-load supplies. The XR76203, XR76205 and XR76208 have load current ratings of 3A, 5A and 8A respectively. A wide 5V to 40V input voltage range allows for single supply operation from industry standard 24V ±10%, 18V-36V, and rectified 18VAC and 24VAC rails.

With a proprietary emulated current mode Constant On-Time (COT) control scheme, the XR76203, XR76205 and XR76208 provide extremely fast line and load transient response using ceramic output capacitors. They require no loop compensation, simplifying circuit implementation and reducing overall component count. The control loop also provides 0.07% load and 0.15% line regulation and maintains constant operating frequency. A selectable power saving mode allows the user to operate in discontinuous conduction mode (DCM) at light current loads thereby significantly increasing the converter efficiency.

A host of protection features, including over-current, over-temperature, short-circuit and UVLO, helps achieve safe operation under abnormal operating conditions.

The XR76203/5/8 are available in a RoHS-compliant, green/halogen-free space-saving QFN 5x5mm package.

EVALUATION BOARD MANUAL

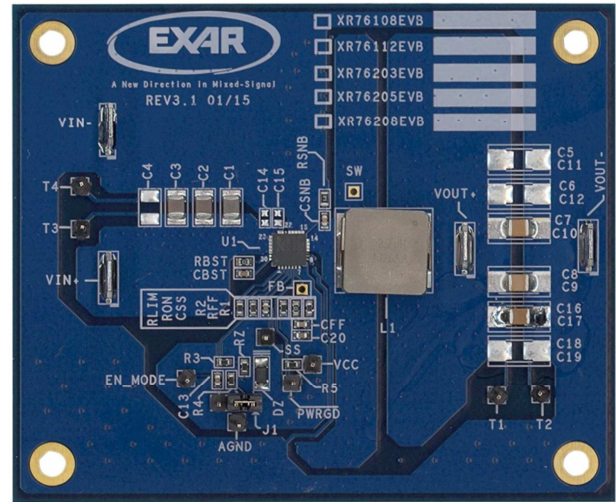

FEATURES

- Controller, drivers, bootstrap diode, MOSFETs integrated in one package
• 3/5/8A Step Down Regulator
- Wide 5V to 40V Input Voltage Range
- ≥0.6V Adjustable Output Voltage
• Proprietary Constant On-Time Control
- No Loop Compensation Required
- Ceramic Output Cap. Stable operation
- Programmable 200ns-2µs On-Time
- Constant 400kHz-600kHz freq.
- Selectable CCM or CCM/DCM Operation
• 30-pin 5x5mm QFN package

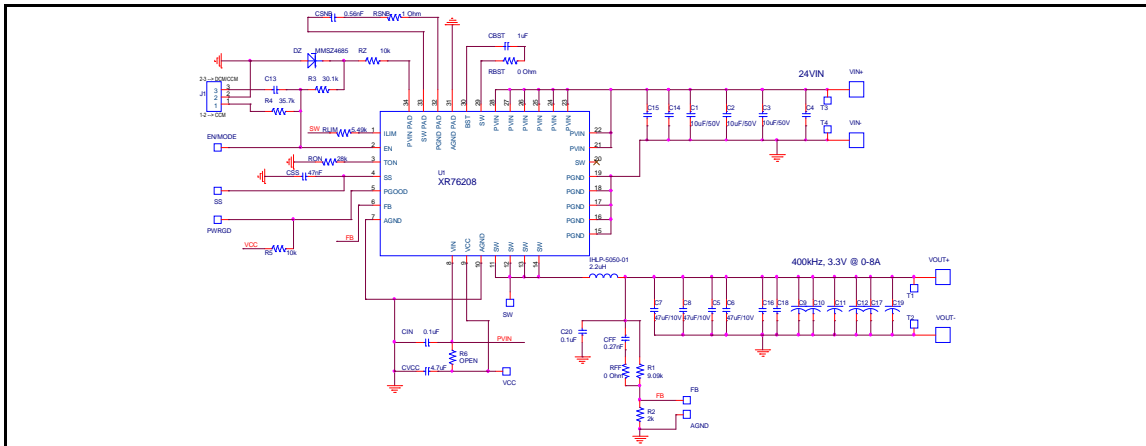

Fig. 1: XR76208 Evaluation Board Schematics



40V, 3/5/8A Synchronous Step Down COT Regulator

PIN ASSIGNMENT

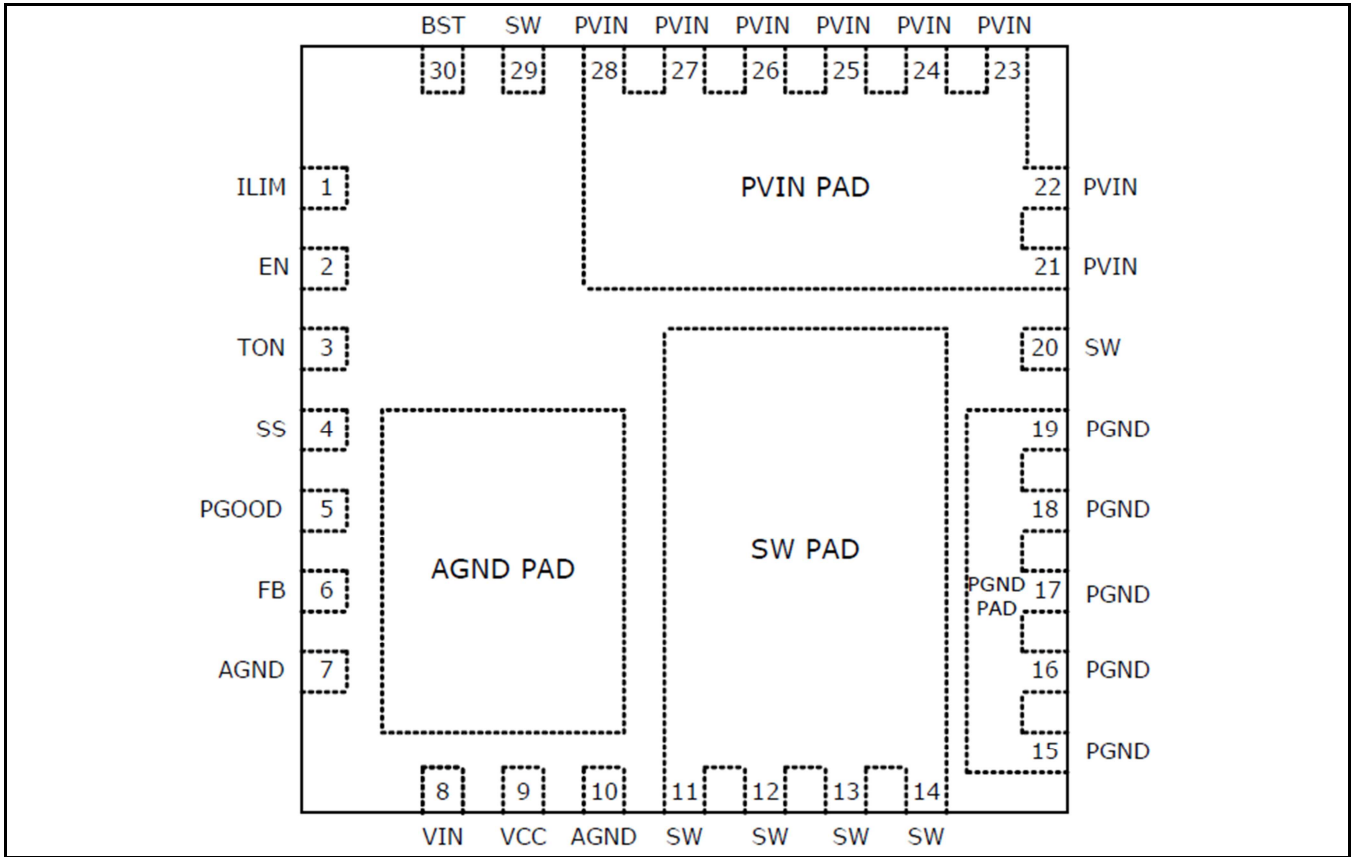

Fig. 2: XR76203/5/8 Pin Assignment

**40V, 3/5/8A Synchronous Step Down COT Regulator****PIN DESCRIPTION**

Pin No.	Pin Name	Type	Description
1	ILIM	A	Over-current protection programming. Connect with a resistor to SW.
2	EN/MODE	I	Precision enable pin. Pulling this pin above 1.9V will turn the regulator on and it will operate in CCM. If the voltage is raised above 3.0V then the regulator will operate in DCM/CCM depending on load
3	TON	A	Constant on-time programming pin. Connect with a resistor to AGND.
4	SS	A	Soft-Start pin. Connect an external capacitor between SS and AGND to program the soft-start rate based on the 10uA internal source current.
5	PGOOD	O, OD	Power-good output. This open-drain output is pulled low when V _{OUT} is outside the regulation.
6	FB	A	Feedback input to feedback comparator. Connect with a set of resistors to V _{OUT} and AGND in order to program V _{OUT} .
7, 10, AGND Pad	AGND	A	Signal ground for control circuitry. Connect AGND Pad with a short trace to pins 7 and 10.
8	VIN	A	Supply input for the regulator's LDO. Normally it is connected to PVIN.
9	VCC	A	The output of regulator's LDO. For operation using a 5V rail, VCC should be shorted to VIN.
11-14, 20, 29, SW Pad	SW	PWR	Switch node. Drain of the low-side N-channel MOSFET. Source of the high-side MOSFET is wire-bonded to the SW Pad. Pins 20 and 29 are internally connected to SW pad.
15-19, PGND Pad	PGND	PWR	Ground of the power stage. Should be connected to the system's power ground plane. Source of the low-side MOSFET is wire-bonded to PGND Pad.
21-28, PVIN Pad	PVIN	PWR	Input voltage for power stage. Drain of the high-side N-channel MOSFET.
30	BST	A	High-side driver supply pin. Connect a bootstrap capacitor between BST and pin 29.

Type: A = Analog, I = Input, O = Output, I/O = Input/Output, PWR = Power, OD = Open-Drain

ORDERING INFORMATION

Refer to XR76203/5/8 datasheet and/or www.exar.com for exact and up to date ordering information.

**40V, 3/5/8A Synchronous Step Down COT Regulator**

USING THE EVALUATION BOARD**POWERING UP**

Connect the VIN+/VIN- with short/thick leads to power supply. Use test pins T4 and T4 to monitor VIN+ and VIN- respectively. Connect VOUT+/VOUT- with short/thick leads to an electronic load. Use test pins T1 and T2 to monitor VOUT+ and VOUT- respectively. Apply 24V using the power supply. The XR76203/5/8EVB should power up and regulate the output at 3.3V. Input voltage range is from 5V to 40V. Maximum rated current for XR76203/5/8 is 3/5/8A respectively.

JUMPER J1

If the jumper is set to right side the regulator will operate in “forced CCM”.

If the Jumper is set to the left side the regulator will operate in DCM at light load.

PROGRAMMING THE OUTPUT VOLTAGE

V_{OUT} can be programmed by changing R1 according to:

$$R1 = R2 \times \left(\frac{V_{OUT}}{0.6} - 1 \right)$$



40V, 3/5/8A Synchronous Step Down COT Regulator

XR76203 EVALUATION BOARD SCHEMATICS

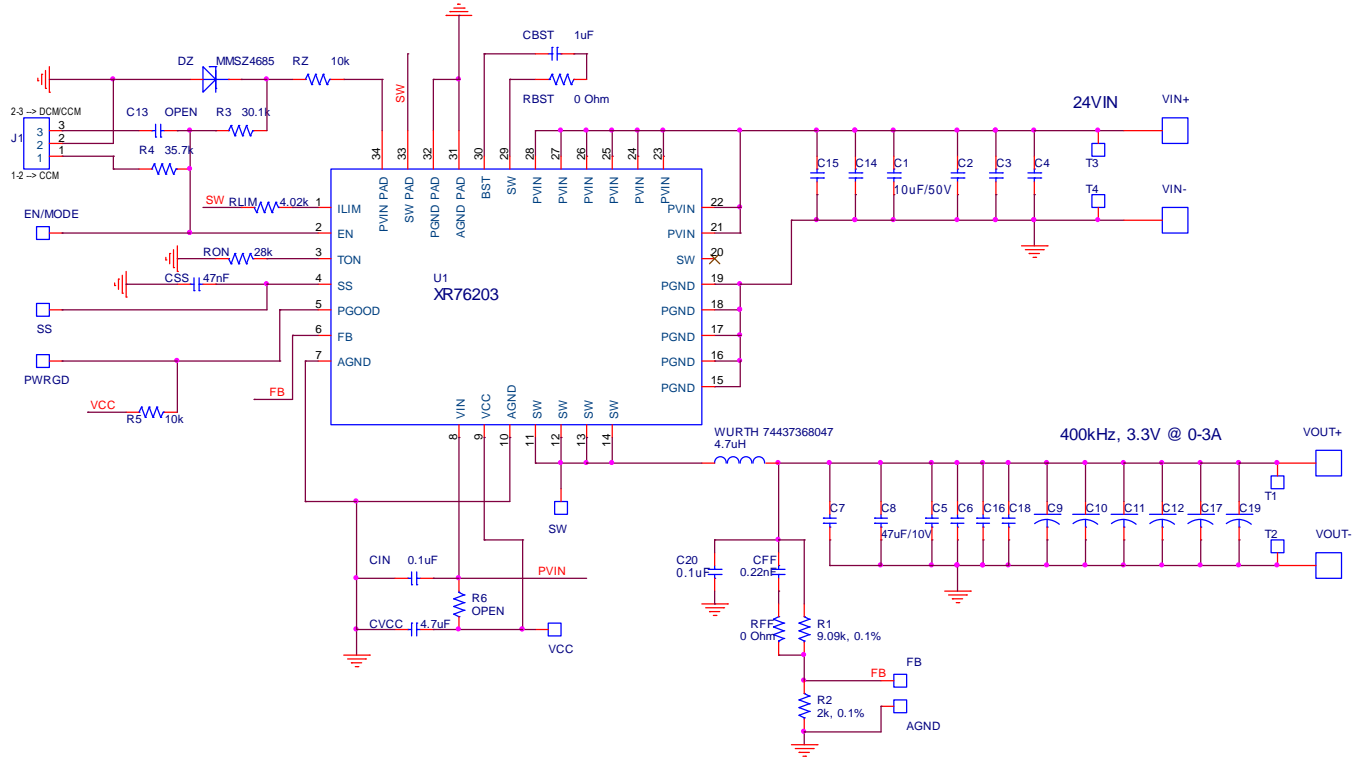



40V, 3/5/8A Synchronous Step Down COT Regulator

XR76203EVB BILL OF MATERIAL

Reference Designator	Qty.	Manufacturer	Manufacturer Part Number	Size	Component
PCB	1	Exar	XR76203		XR76203 Evaluation kit
U1	1	Exar	XR76203		40V, 3A COT Regulator
L1	1	Würth Elektronik	74437368047	11x10mm	Power Inductor 4.7uH, 7.0A, 15.0 mOhm
DZ	1	ON SEMI	MMSZ4685T1G	SOD-123	Diode Zener 3.6V, 500MW,
C1	1	MURATA	GRM32E71H106KA12L	1210	CERAMIC CAP. 10uF, 50V, X7R, 10%
C8	1	MURATA	GRM32ER71A476KE15L	1210	CERAMIC CER, 47uF, 10V, X7R, 10%
CVCC	1	MURATA	GRM21BR71C475KA73L	0805	CERAMIC CAP , 4.7uF, 16V, X7R, 10%
CIN, C20	2	MURATA	GRM188R71H104KA93D	0603	CERAMIC CAP., 0.1uF, 50V, X7R, 10%
CBST	1	MURATA	GRM188R71C105KA12D	0603	CERAMIC CAP., 1.0 uF, 16V, X7R, 10%
CFF	1	MURATA	GRM188R71H221KA01D	0603	CERAMIC CAP. , 220 pF, 50V, X7R, 10%
CSS	1	MURATA	GRM188R71H473KA61D	0603	CERAMIC CAP. 0.047uF, 50V,X7R,10%
R1	1	PANASONIC	ERJ-3EKF9091V	0603	Resistor 9.09K Ohm, 1/10W,1%,SMD
R5,RZ	2	PANASONIC	ERJ-3EKF1002V	0603	Resistor 10.0K Ohm, 1/10W,1%,SMD
R3	1	PANASONIC	ERJ-3EKF3012V	0603	Resistor 30.1K Ohm, 1/10W,1%,SMD
R4	1	PANASONIC	ERJ-3EKF3572V	0603	Resistor 35.7K Ohm, 1/10W, 1%, SMD
RFF, RBST	2	PANASONIC	ERJ-3GEY0R00V	0603	Resistor 0.00 Ohm, Jumper, 1/10W, SMD
R2	1	PANASONIC	ERA-3YEB202V	0603	Resistor 2.0K Ohm, 1/10W, 0.1%, SMD
RLIM	1	PANASONIC	ERJ-3EKF4021V	0603	Resistor 4.02K Ohm, 1/10W,1%,SMD
RON	1	PANASONIC	ERJ-3EKF2802V	0603	Resistor 28.0K Ohm, 1/10W,1%, SMD
J1	1	Würth Elektronik	61300311121		3-PIN CONNECTOR
VIN+, VOUT+, VIN-, VOUT- T1,T2,T3,T4,SS,VCC,PWR GD, AGND, EN MODE	4	Würth Elektronik	7471287		CONNECTOR BLADE TERMINAL
	9	Würth Elektronik	61300111121		SINGLE Test Point Post



40V, 3/5/8A Synchronous Step Down COT Regulator

XR76205 EVALUATION BOARD SCHEMATICS

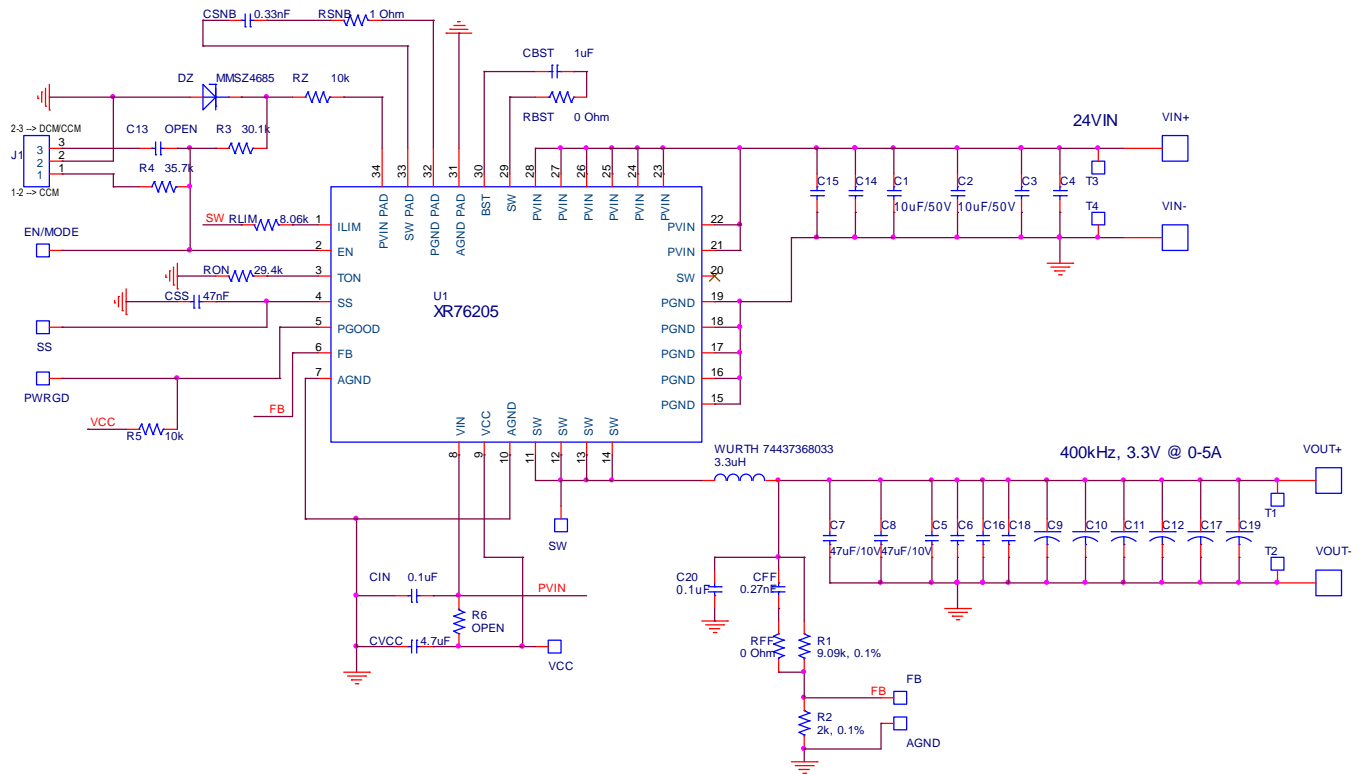



40V, 3/5/8A Synchronous Step Down COT Regulator

XR76205EV B BILL OF MATERIAL

Reference Designator	Qty.	Manufacturer	Manufacturer Part Number	Size	Component
PCB	1	Exar	XR76205		XR76205 Evaluation Kit
U1	1	Exar	XR76205		40V, 5A COT Regulator
L1	1	Würth Elektronik	74437368033	11x10mm	Power Inductor 3.3uH, 8.0A, 11.8mOhm
DZ	1	ON SEMI	MMSZ4685T1G	SOD-123	Diode Zener 3.6V, 500MW,
C1, C2	2	MURATA	GRM32E71H106KA12L	1210	CERAMIC CAP. 10uF, 50V, X7R, 10%
C7, C8	2	MURATA	GRM32ER71A476KE15L	1210	CERAMIC CER, 47uF, 10V, X7R, 10%
CVCC	1	MURATA	GRM21BR71C475KA73L	0805	CERAMIC CAP , 4.7uF, 16V, X7R, 10%
CIN, C20	2	MURATA	GRM188R71H104KA93D	0603	CERAMIC CAP., 0.1uF, 50V, X7R, 10%
CBST	1	MURATA	GRM188R71C105KA12D	0603	CERAMIC CAP., 1.0 Uf, 16V, X7R, 10%
CFF	1	MURATA	GRM188R71H271KA01D	0603	CERAMIC CAP. , 270 pF, 50V, X7R, 10%
CSNB	1	MURATA	GRM188R71H331KA01D	0603	CERAMIC CAP. 0.33 nF, 50V,X7R,10%
CSS	1	MURATA	GRM188R71H473KA61D	0603	CERAMIC CAP. 0.047uF, 50V,X7R,10%
R1	1	PANASONIC	ERJ-3EKF9091V	0603	Resistor 9.09K Ohm, 1/10W,1%,SMD
R5,RZ	2	PANASONIC	ERJ-3EKF1002V	0603	Resistor 10.0K Ohm, 1/10W,1%,SMD
R3	1	PANASONIC	ERJ-3EKF3012V	0603	Resistor 30.1K Ohm, 1/10W,1%,SMD
R4	1	PANASONIC	ERJ-3EKF3572V	0603	Resistor 35.7K Ohm, 1/10W, 1%, SMD
RFF, RBST	2	PANASONIC	ERJ-3GEY0R00V	0603	Resistor 0.00 Ohm, Jumper, 1/10W, SMD
R2	1	PANASONIC	ERA-3YEB202V	0603	Resistor 2.0K Ohm, 1/10W, 0.1%, SMD
RLIM	1	PANASONIC	ERJ-3EKF8061V	0603	Resistor 8.06K Ohm, 1/10W,1%,SMD
RON	1	PANASONIC	ERJ-3EKF2942V	0603	Resistor 29.4K Ohm, 1/10W,1%, SMD
RSNB	1	PANASONIC	ERJ-6RQF1R0V	0805	Resistor 1.0 Ohm,1/8W,1%,SMD
J1	1	Würth Elektronik	61300311121		3-PIN CONNECTOR
VIN+, VOUT+, VIN-,VOUT- T1,T2,T3,T4,SS,VCC,PWR GD, AGND, EN_MODE	4	Würth Elektronik	7471287		CONNECTOR BLADE TERMINAL
	9	Würth Elektronik	61300111121		SINGLE Test Point Post



40V, 3/5/8A Synchronous Step Down COT Regulator

XR76208 EVALUATION BOARD SCHEMATICS

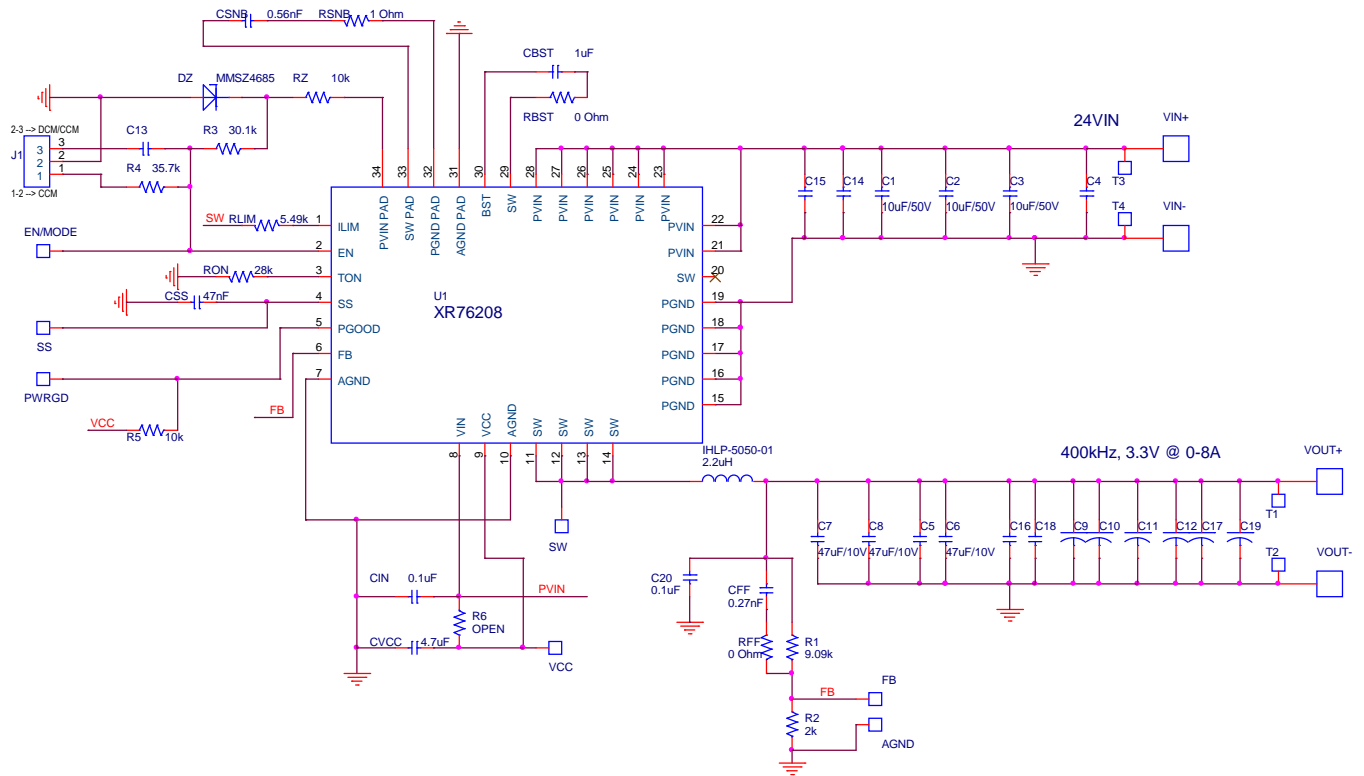



40V, 3/5/8A Synchronous Step Down COT Regulator

XR76208EVB BILL OF MATERIAL

Reference Designator	Qty.	Manufacturer	Manufacturer Part Number	Size	Component
PCB	1	Exar	XR76208		XR76208 Evaluation kit
U1	1	Exar	XR76208		40V, 8A COT Regulator
L1	1	Vishay	IHLP5050FDER2R2M01	12.9x13.2mm	Inductor High Current 2.2uH, 22A, 4.2 mOhm
DZ	1	ON SEMI	MMSZ4685T1G	SOD-123	Diode Zener 3.6V, 500MW,
C1, C2, C3	3	MURATA	GRM32E71H106KA12L	1210	CERAMIC CAP. 10uF, 50V, X7R, 10%
C6,C7, C8	3	MURATA	GRM32ER71A476KE15L	1210	CERAMIC CER, 47uF, 10V, X7R, 10%
CVCC	1	MURATA	GRM21BR71C475KA73L	0805	CERAMIC CAP , 4.7uF, 16V, X7R, 10%
CIN, C20	2	MURATA	GRM188R71H104KA93D	0603	CERAMIC CAP., 0.1uF, 50V, X7R, 10%
CBST	1	MURATA	GRM188R71C105KA12D	0603	CERAMIC CAP., 1.0 Uf, 16V, X7R, 10%
CFF	1	MURATA	GRM188R71H271KA01D	0603	CERAMIC CAP. , 270 pF, 50V, X7R, 10%
CSNB	1	MURATA	GRM188R71H561KA01D	0603	CERAMIC CAP. 0.56 nF, 50V,X7R,10%
CSS	1	MURATA	GRM188R71H473KA61D	0603	CERAMIC CAP. 0.047uF, 50V,X7R,10%
R1	1	PANASONIC	ERJ-3EKF9091V	0603	Resistor 9.09K Ohm, 1/10W,1%,SMD
R5,RZ	2	PANASONIC	ERJ-3EKF1002V	0603	Resistor 10.0K Ohm, 1/10W,1%,SMD
R3	1	PANASONIC	ERJ-3EKF3012V	0603	Resistor 30.1K Ohm, 1/10W,1%,SMD
R4	1	PANASONIC	ERJ-3EKF3572V	0603	Resistor 35.7K Ohm, 1/10W, 1%, SMD
RFF, RBST	2	PANASONIC	ERJ-3GEY0R00V	0603	Resistor 0.00 Ohm, Jumper, 1/10W, SMD
R2	1	PANASONIC	ERA-3YEB202V	0603	Resistor 2.0K Ohm, 1/10W, 0.1%, SMD
RLIM	1	PANASONIC	ERJ-3EKF5491V	0603	Resistor 5.49K Ohm, 1/10W,1%, SMD
RON	1	PANASONIC	ERJ-3EKF2802V	0603	Resistor 28.0K Ohm, 1/10W,1%, SMD
RSNB	1	PANASONIC	ERJ-6RQF1R0V	0805	Resistor 1.0 Ohm,1/8W,1%,SMD
J1	1	Würth Elektronik	61300311121		3-PIN CONNECTOR
VIN+, VOUT+, VIN-,VOUT- T1,T2,T3,T4,SS,VCC,PWR GD, AGND, EN MODE	4	Würth Elektronik	7471287		CONNECTOR BLADE TERMINAL
	9	Würth Elektronik	61300111121		SINGLE Test Point Post



EVALUATION BOARD LAYOUT

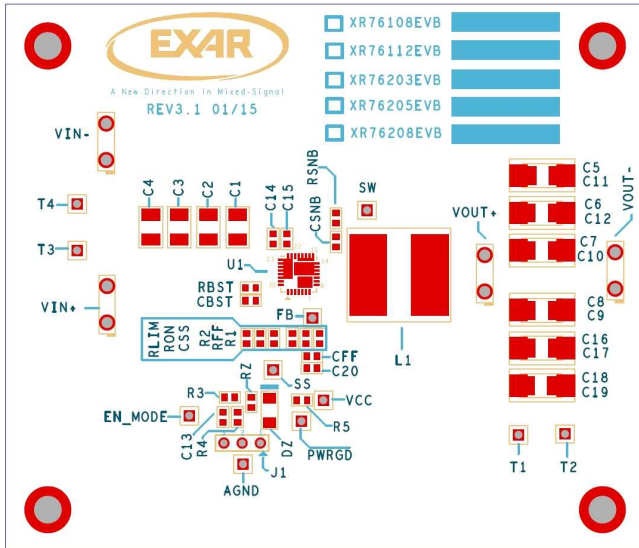

Fig. 3: Top components

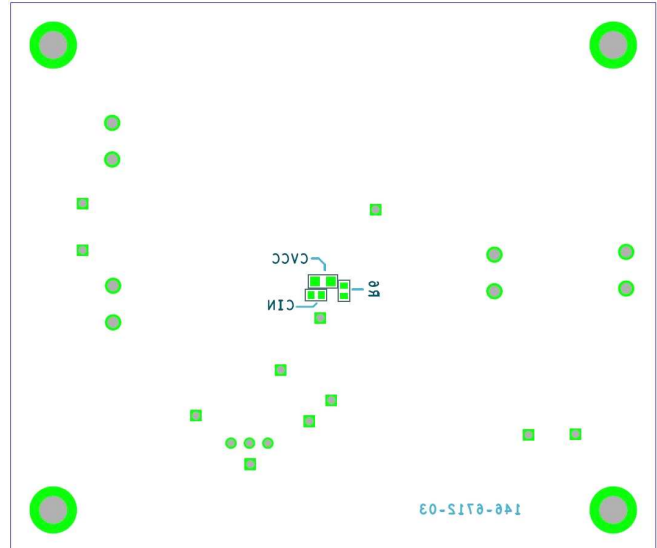

Fig. 4: Bottom components

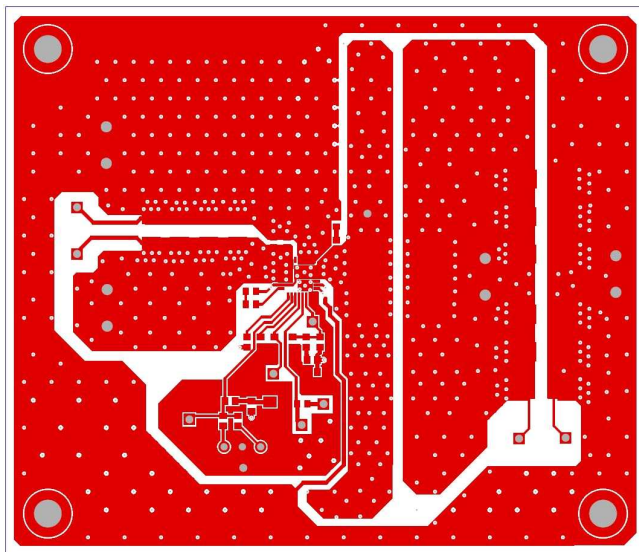

Fig. 5: Top

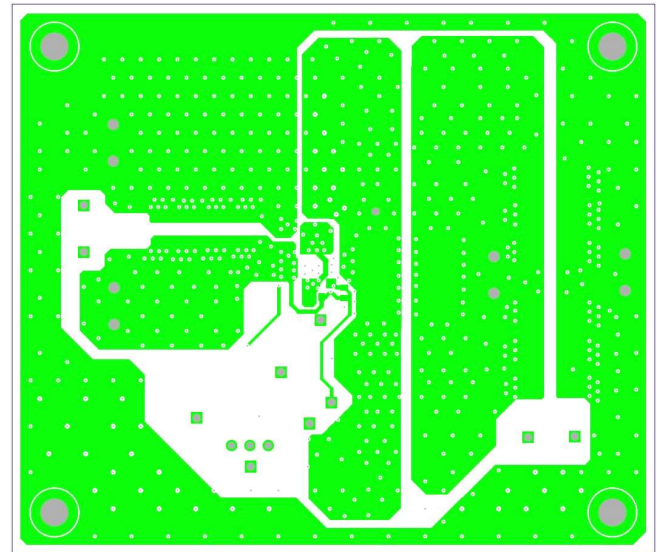

Fig. 6: Bottom



40V, 3/5/8A Synchronous Step Down COT Regulator

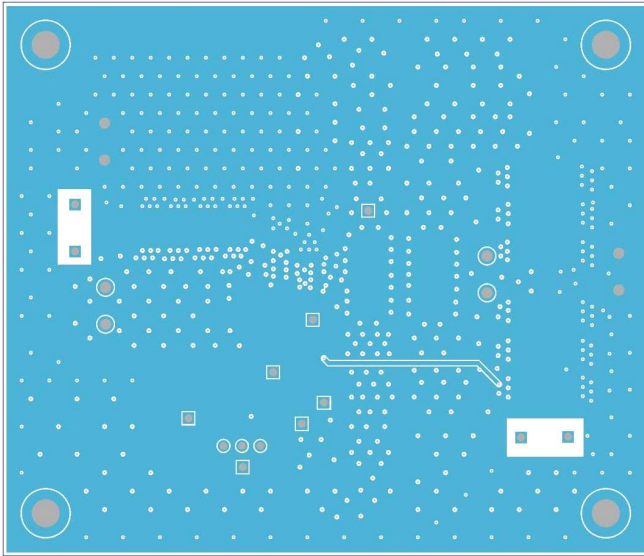

Fig. 7: Layer 2, GND 1

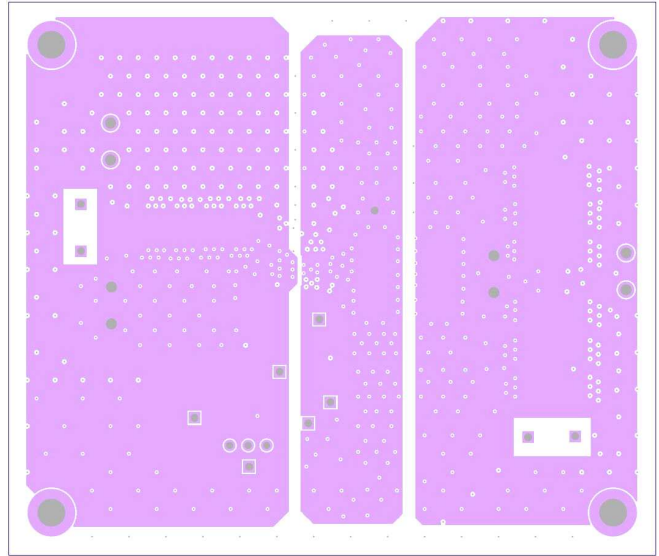

Fig. 8: Layer 3, VCC1

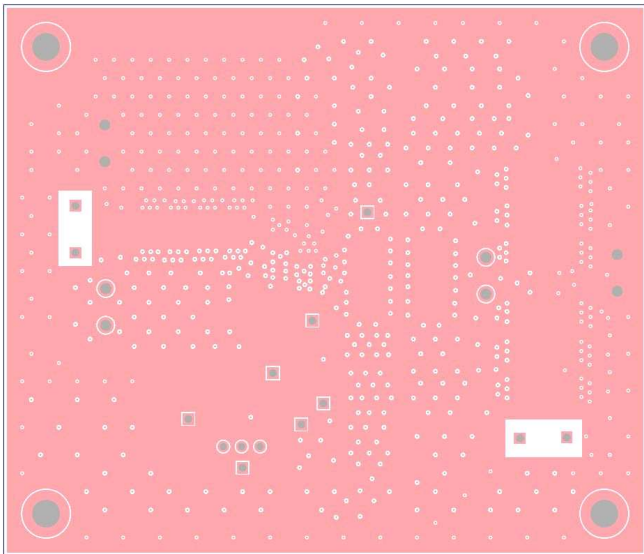

Fig. 9: Layer 4, GND 2

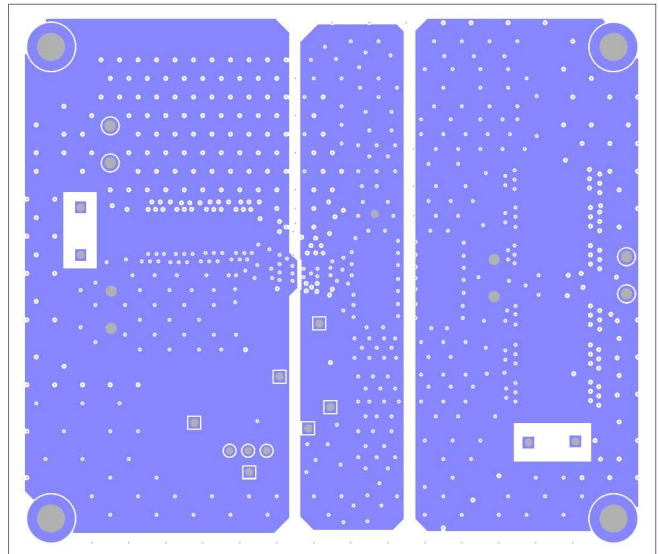

Fig. 10: Layer 5, VCC2



40V, 3/5/8A Synchronous Step Down COT Regulator

DOCUMENT REVISION HISTORY

Revision	Date	Description
1A	02/20/15	Initial release of document

BOARD REVISION HISTORY

Board Revision	Date	Description
REV 3.1	02/20/15	Initial release of evaluation board

FOR FURTHER ASSISTANCE

Email:

customersupport@exar.com

powertechsupport@exar.com

Exar Technical Documentation:

<http://www.exar.com/TechDoc/>

EXAR CORPORATION

HEADQUARTERS AND SALES OFFICES

48720 Kato Road

Fremont, CA 94538 – USA

Tel.: +1 (510) 668-7000

Fax: +1 (510) 668-7030

www.exar.com



NOTICE

EXAR Corporation reserves the right to make changes to the products contained in this publication in order to improve design, performance or reliability. EXAR Corporation assumes no responsibility for the use of any circuits described herein, conveys no license under any patent or other right, and makes no representation that the circuits are free of patent infringement. Charts and schedules contained herein are only for illustration purposes and may vary depending upon a user's specific application. While the information in this publication has been carefully checked; no responsibility, however, is assumed for inaccuracies.

EXAR Corporation does not recommend the use of any of its products in life support applications where the failure or malfunction of the product can reasonably be expected to cause failure of the life support system or to significantly affect its safety or effectiveness. Products are not authorized for use in such applications unless EXAR Corporation receives, in writing, assurances to its satisfaction that: (a) the risk of injury or damage has been minimized; (b) the user assumes all such risks; (c) potential liability of EXAR Corporation is adequately protected under the circumstances.

Reproduction, in part or whole, without the prior written consent of EXAR Corporation is prohibited.

X-ON Electronics

Largest Supplier of Electrical and Electronic Components

Click to view similar products for [Power Management IC Development Tools](#) category:

Click to view products by [MaxLinear](#) manufacturer:

Other Similar products are found below :

[EVAL-ADM1168LQEBZ](#) [EVB-EP5348UI](#) [MIC23451-AAAYFL EV](#) [MIC5281YMME EV](#) [DA9063-EVAL](#) [ADP122-3.3-EVALZ](#) [ADP130-0.8-EVALZ](#) [ADP130-1.2-EVALZ](#) [ADP130-1.5-EVALZ](#) [ADP130-1.8-EVALZ](#) [ADP1712-3.3-EVALZ](#) [ADP1714-3.3-EVALZ](#) [ADP1715-3.3-EVALZ](#) [ADP1716-2.5-EVALZ](#) [ADP1740-1.5-EVALZ](#) [ADP1752-1.5-EVALZ](#) [ADP1828LC-EVALZ](#) [ADP1870-0.3-EVALZ](#) [ADP1871-0.6-EVALZ](#) [ADP1873-0.6-EVALZ](#) [ADP1874-0.3-EVALZ](#) [ADP1882-1.0-EVALZ](#) [ADP199CB-EVALZ](#) [ADP2102-1.25-EVALZ](#) [ADP2102-1.875EVALZ](#) [ADP2102-1.8-EVALZ](#) [ADP2102-2-EVALZ](#) [ADP2102-3-EVALZ](#) [ADP2102-4-EVALZ](#) [ADP2106-1.8-EVALZ](#) [ADP2147CB-110EVALZ](#) [AS3606-DB](#) [BQ24010EVM](#) [BQ24075TEVM](#) [BQ24155EVM](#) [BQ24157EVM-697](#) [BQ24160EVM-742](#) [BQ24296MEVM-655](#) [BQ25010EVM](#) [BQ27411EVM-G1A](#) [BQ3055EVM](#) [NCV891330PD50GEVB](#) [ISLUSBI2CKIT1Z](#) [LM2744EVAL](#) [LM2854EVAL](#) [LM3658SD-AEV/NOPB](#) [LM3658SDEV/NOPB](#) [LM3691TL-1.8EV/NOPB](#) [LM4510SDEV/NOPB](#) [LM5033SD-EVAL](#)