



XR77XXEVB-XCM-V80 XR77XX Configuration Module

April 2016

Rev. 1.0.0

GENERAL DESCRIPTION

The XR77XXEVB-XCM-V80 (Exar Configuration Module or XCM) is a board that is designed to act as a USB to I²C bridge for communication between a PC running PowerArchitect™ 4 configuration and design software and one of Exar's Universal PMICs. The PMIC can either be on an Exar evaluation board or on a customer board. On the right opposite side of the XCM is a 10-pin connector which is used to connect to the user's system board in order to communicate to any of the supported PMICs.

The XCM includes a μ C with on-board flash so that when powered from the system board, it can act as a boot loader without the need to have a PC connected.

This board is compatible with: XR77103, XRP7704, XRP7708, XRP7740, XRP7713, and XRP7714.

EVALUATION BOARD MANUAL



FEATURES

- **USB to I²C Communication for Programmable PMIC Devices**
- **Boot Loader Functionality**
 - Avoids programming the NVM until final configuration known
- **Powered by USB or System Board**
- **Enables Rapid Prototyping**

EVALUATION BOARD SCHEMATICS

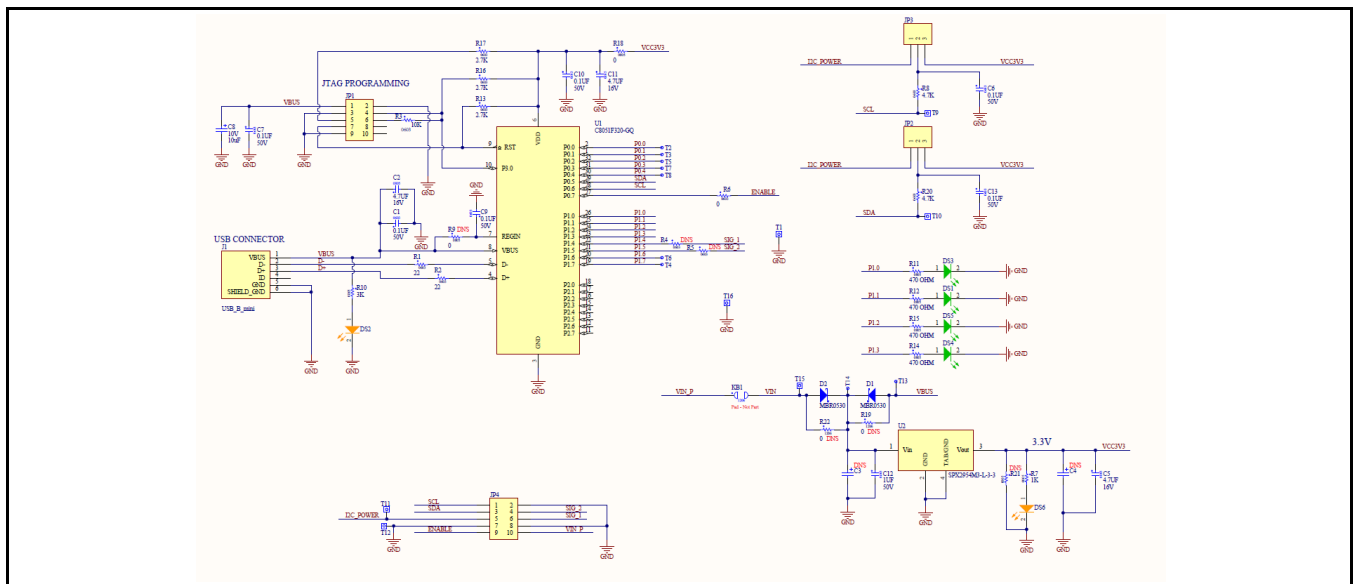

Figure 1: XR77XXEVB-XCM-V80 Evaluation Board Schematics

PIN ASSIGNMENT

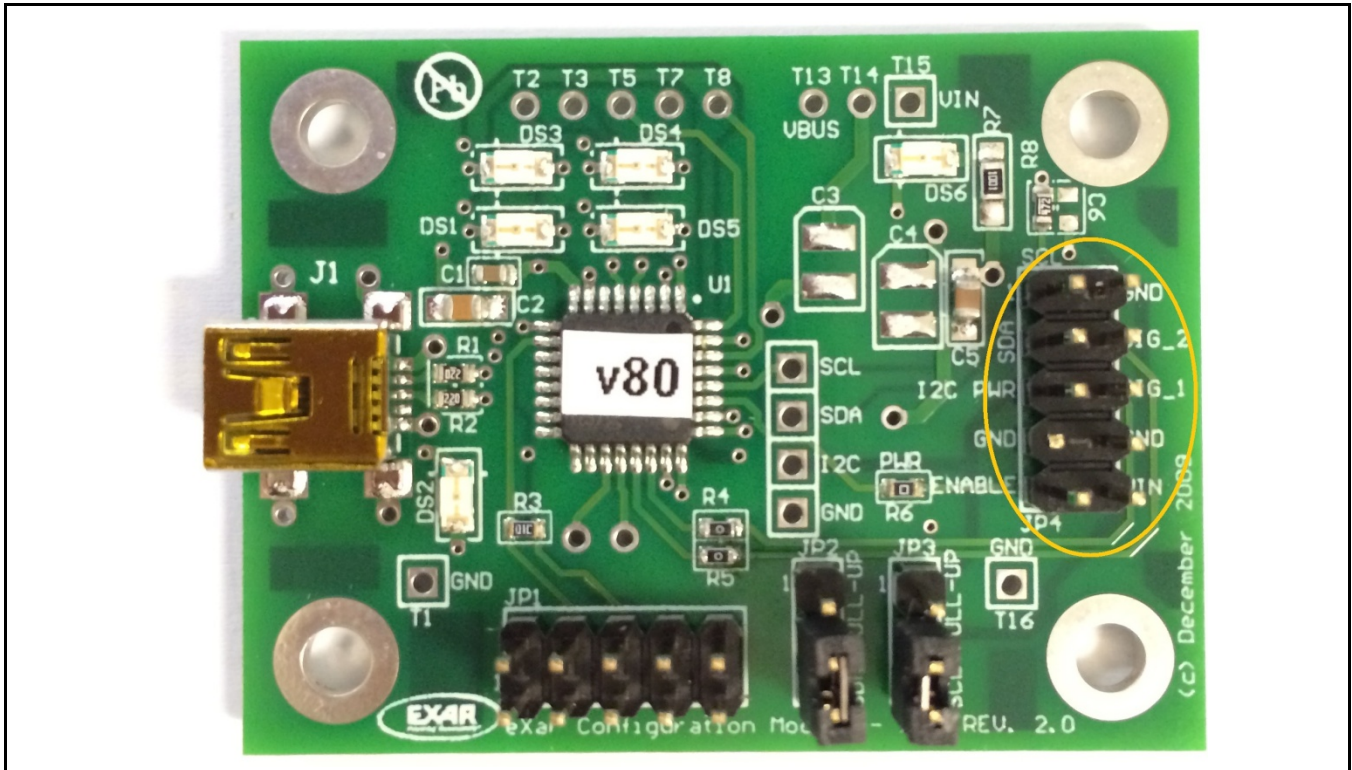

Figure 2: XR77XXEVB-XCM-V80 JP4 Pin Assignment

PIN DESCRIPTION

Name	Pin Number	Description
SCL	JP4 PIN1	I2C Clock
GND	JP4 PIN2	Ground
SDA	JP4 PIN3	I2C Data
Sig_2	JP4 PIN4	General purpose signal 2
I ² C Power	JP4 PIN5	Connect to the preferred IO voltage. Only required when a voltage other than 3.3V is desired.
Sig_1	JP4 PIN6	General purpose signal 1
GND	JP4 PIN7	Ground
GND	JP4 PIN8	Ground
ENABLE	JP4 PIN9	Connects to the EN pin of the XRP77XX. This is an input to the XCM board.
VIN	JP4 PIN10	Can connect to voltages from 4.5V to 30V

ORDERING INFORMATION

Part Number	Description
XR77XXEVB-XCM-V80	Exar Configuration Module for Power Architect 4 Support



USING THE EVALUATION BOARD

OPERATING ASSUMPTIONS

The following are the basic assumptions for the operation of the XCM.

- Only one I²C Master is active at any time on the customer board. The user must ensure that only 1 master is active on the I²C lines at the same time. This could entail Host in Reset, Host communication lines disabled, etc.
- The user must connect the appropriate signals to from the system board to the XCM JP4. At a minimum; SDA, SCL, and GND must be connected.
- VIN and ENABLE must also be connected, if the customer wants the XCM board to operate in "Standalone Mode" (not supported with XR77103).

Using I²C Communication

The XCM has an on board linear regulator to provide power to the μ C and provides power to the I²C lines. The I²C bus pull-up resistors are 4.7kohm. By changing the position of the jumpers on JP2 and JP3, the pull-up resistors can be connected to either the 3.3V provided on the XCM or to the I²C Power connected to JP4 Pin 5. In Figure 2 the jumpers are configured to use the on board 3.3V. Moving them to the other position connects the pull-up resistors to the external I²C Power.

IMPORTANT: When using the XCM with XRP7713EVB or XRP7714EVB demo boards, the jumpers should be configured to use the 3.3V provided on the XCM. When using with the XR77103EVB board, the jumpers should be removed since the I²C bus pull-up resistors are installed on the XR77103EVB.

If the system board already has pull-up resistors, then the jumpers can simply be removed. This is the most likely scenario for a system intended to interact with the programmable features of the PMIC device on the system board.

COMMUNICATION WITH THE XCM

If the XCM is connected to the PC before starting the PowerArchitect™ 4 software, the software should recognize the presence of the board automatically. If the board is connected after the software is started, the user will need to click on "File", then "Board Search" for the software to find the board.

Once the board is identified, the software will add a tab called "XCM" as shown in Figure 3.

This feature is not available for XR77103 device.

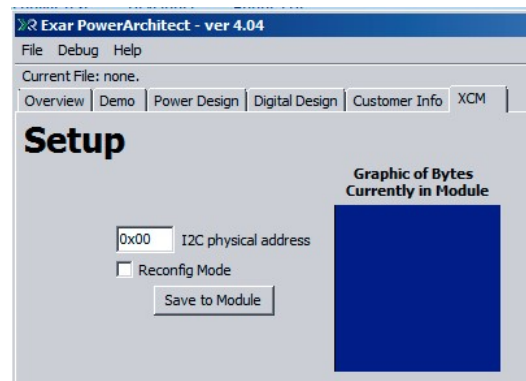

Figure 3: PowerArchitect™ 4 XCM Tab

LED INDICATORS:

There are 6 LEDs on the board.

There are four LEDs grouped in the upper left hand corner of the board as shown in Figure 3.

These are defined as:

DS3: USB Operation

GUI is communicating to XCM (solid on when USB is connected)

DS4: Reconfig Mode

The XCM will boot load the supported device with the stored configuration the ENABLE pin transitions from Low to High (not available for XR77103).

DS1: USB Activity

Flashes based upon the USB activity between the XCM and the PC.



DS5: I2C Activity

Flashes based upon the I²C activity between the XCM and the PMIC.

DS3: USB Power

There is a fifth LED just to the right of the USB connector, which will be on permanently as long as USB power is applied to the XCM.

DS6: 3.3V Power

The sixth LED is in the upper right hand corner. This indicates the LDO is generating 3.3V and the μ C is powered.

OPERATING THE XCM

Here are the two basic operating modes of the XCM.

- **Pass Through Mode:** The XCM is getting its power from the USB, and the PowerArchitect™ 4 GUI is operational. In this mode, the “USB Operating” LED DS3 will be on.
- **Standalone Mode:** The XCM is getting its power from VIN of the Customer Board; the GUI is not operational. In this mode, the XCM acts as a boot loader to the supported device (not available for XR77103).

PASS THROUGH MODE

When in USB Mode, the XCM supports pass-thru mode from the PC running PowerArchitect™ 4 to the supported device on the designer’s system board. This operation allows writes/reads to either the shadow registers or Non-Volatile Memory of the supported device

- XCM receives commands from the GUI (over USB), and translates them via I²C.
- The GUI has the option to write a given configuration to NVM or Shadow Registers of the supported device.
- XCM also supports reads from the supported device shadow and NVM registers for display in PowerArchitect™ 4.

STANDALONE MODE

This mode is not supported for XR77103.

The XCM allows the GUI to save a configuration into Flash on the XCM. In order to enable the boot loader functionality, the “Reconfig Mode” box must be checked. When there is a stored configuration on the XCM flash, the GUI will indicate the presence of that information in the “Graphic of Bytes” box. To store a configuration to the XCM, click the “Same to Module” button.

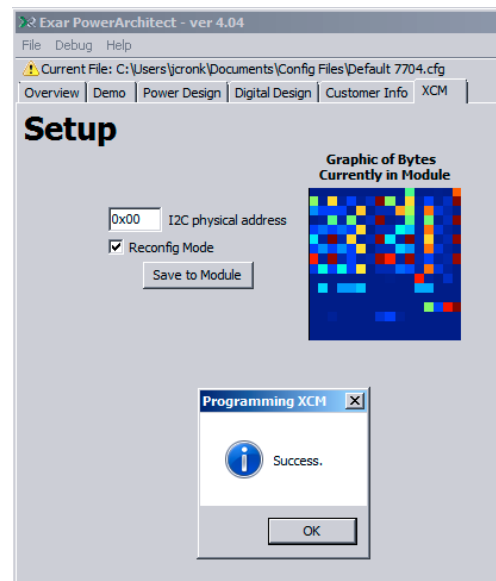

Figure 5: XCM Loaded for Standalone Mode

Note that only one configuration can be stored in the XCM. When storing the configuration onto the XCM, a “Success” window will pop up. After clicking “OK” there can be a noticeable delay in the software.

Powering the XCM

In order to operate, the XCM must have power provided either by connecting the VIN pin on JP4 to a power source from the system board or from USB power.

The XCM’s on board linear regulator has a maximum input voltage of 30V, so whatever voltage source is powering the PMIC device on the system board can be connected to the XCM.



Downloading the Configuration

The XCM will download the configuration stored on the XCM FLASH memory on every reset of the supported device. It does by monitoring the ENABLE Pin for a LOW to HIGH transition (this is not supported for XR77103).

The XCM automatically downloads the saved Flash configuration into the supported device shadow registers via I²C. The register data is loaded in a specific order to prevent mis-operation of the supported device. The XCM first configures Fault Ignore settings, downloads channel information, and finally configures the channel and GPIO enables.

One could imagine the result, if the channel was enabled before the control loop PID coefficients were loaded.

NVM Programming

When in Standalone Mode, the primary intention for the XCM is to act as a boot loader into the shadow RAM. However, by installing a jumper between pins 2-4 on JP1, the XCM will program the NVM. There are no diagnostics in this mode. If a device's NVM has already been programmed, it cannot be re-programmed. If a changed configuration is attempted to be programmed into a previously programmed part, erroneous behavior is highly likely. The reason for including this function is for the developer who has concluded their evaluation and wishes to quickly program the NVM of the PMIC device on additional systems (not available for XR77103).

XR77103 support

Power Architect™ 4.24 or later makes use of the Sig_1 and Sig_2 signals to poll for PGOOD status from XR77103 and control the nWR pin during XR77103 NVM programming respectively. More information on the Power Architect™ XR77103 support is available in "Power Architect 4 Quick Start Guide".

WHEN THINGS DO NOT WORK

The following are potential issues that may cause improper or no operation.

- SCL, SDA, or GND are swapped.
- Check that the I2C pull-up resistor jumpers on JP2 and JP3 are in place. Or correctly configured for your system.
- If you made your own ribbon cable with a 10 pin connector and accidentally attach it reversed, you just tied VIN to SCL and damaged the μ C. Time for a new XCM.
- You are using 2 foot long wires hanging loose creating an inductive loop which is blocking the I2C communication. Twisting them together should reduce the inductance.
- You can communicate to the part when it is not operating, but when you turn on the switching channels, communication stops. This is difficult to fix because the most likely cause is ground bounce caused by poor grounding practices. See ANP-32, "Practical Layout Guidelines for Universal PMIC Controllers"
- Another possibility if communication is not working is a long ground loop causing noise. One could put an isolator on the I2C line, but using a notebook computer with the power adapter disconnected works as well.



XR77XXEVB-XCM-V80

XR77XX Configuration Module

EVALUATION BOARD SCHEMATICS

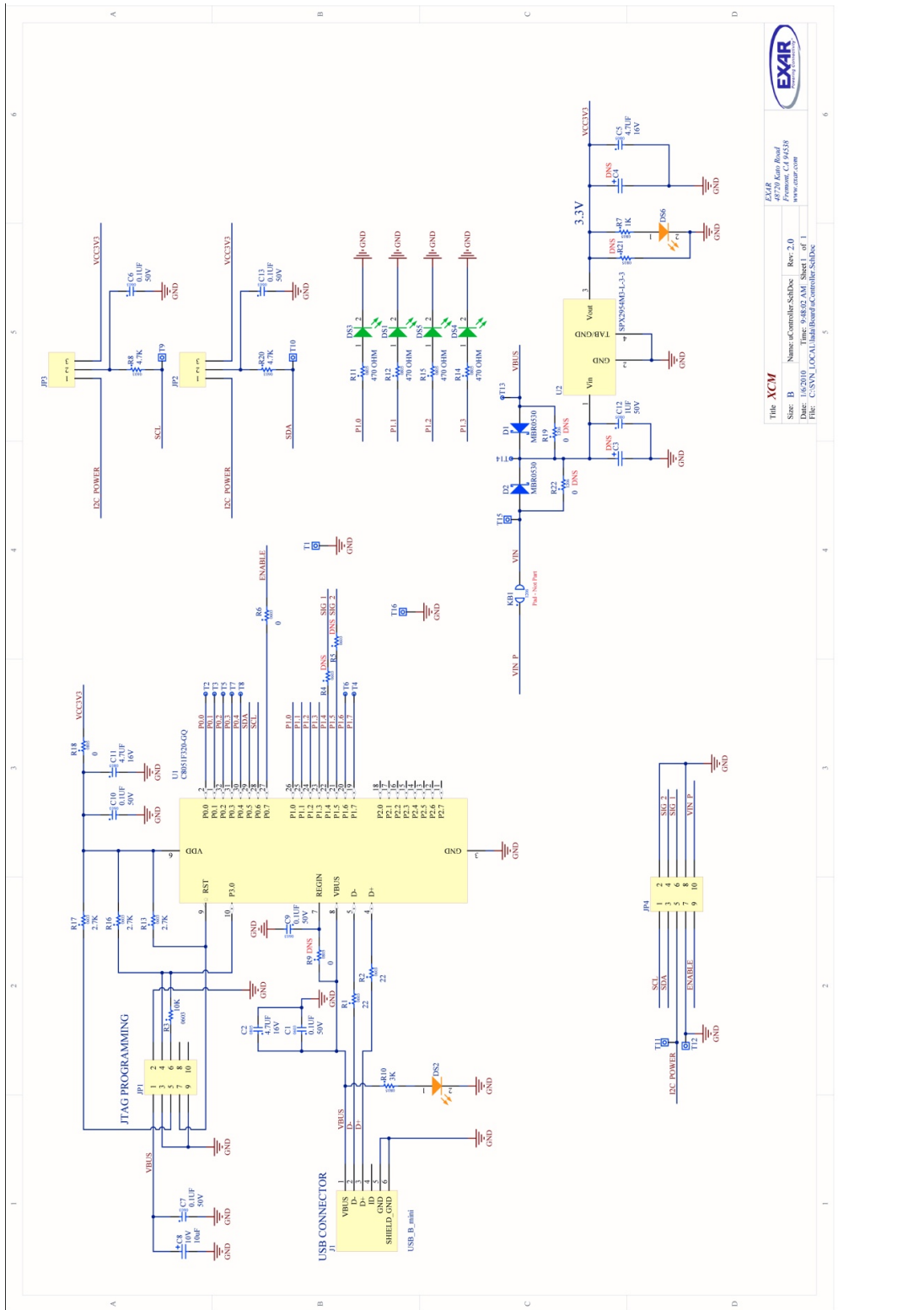



XR77XXEVB-XCM-V80

XR77XX Configuration Module

BILL OF MATERIAL

Ref.	Qty	Manufacturer	Part Number	Size	Component
	1				PCB REV2.0
U1	1	Silicon Laboratories	C8051F320-GQ	LQFP-32	IC 8051 MCU 16K FLASH 32LQFP
U2	1	EXAR	SPX2954M3-L-3-3	SOT-223	IC REG LDO 3.3V SOT-223
D1, D2	2	Fairchild	MBR0530T1	SOD-323	DIODE SCHOTTKY 500mA 30V
DS2, DS6	2	Würth Elektronik	150120EAS75000	1206p	LED AMBER SMD
DS1, DS3, DS4, DS5	4	Würth Elektronik	150120EVS75000	1206p	LED GREEN SMD
C1, C7, C9, C10	4	MURATA	GRM188R71H104K	0603	Cap, .1uF, 50V, X7R, 10%, 0603 SMD
C2, C5, C11	3	MURATA	GRM21BR71C475KA73	0805	C_Chip_4.7uF_16V_X7R_0805 SMD
C8	1	Vishay	293D106X9010B2TE3	B TANT CAP	Cap, Tantalum 10uF 10V, CASE B
C12	1	MURATA	GRM21BR71H105KA12L	0805	Cap, Ceramic, 1uF 50V, X7R, 10% 0805
R1, R2	2	PANASONIC	ERJ-3EKF22R0V	0603	Res 22 OHM 1% 0603 SMD
R3	1	ROHM	MCR03EZPFX1002	0603	RES 10K 1/10W 1% 0603
R4, R5, R6	3	PANASONIC	ERJ-3GEY0R00V	0603	Res 0 OHM 0603 SMD
R7	1	PANASONIC	ERJ-6ENF1001V	0805	RES 1K OHM 1/8W 5% 0805 SMD
R10	1	PANASONIC	ERJ-6GEYJ302V	0805	RES 3K OHM 1/8W 5% 0805 SMD
R11, R12, R14, R15	4	PANASONIC	ERJ-6GEYJ471V	0805	RES 470 OHM 1/8W 5% 0805
R8, R20	2	PANASONIC	ERJ-3EKF4701V	0603	RES 4.7K OHM 1/10W 1% 0603 SMD
R18	1	PANASONIC	ERJ-6GEY0R00V	0805	Res 0 OHM 0805 SMD
R13, R16, R17	3	PANASONIC	ERJ-3EKF2701V	0603	RES 2.7K OHM 1/10W 1% 0603 SMD
KB1	1	PANASONIC	ERJ-8GEY0R00V	1206	Res 0 OHM 1206 SMD
J1	1	Würth Elektronik	65100516121	USB_B_mini	CONN RECEPT MINIUSB R/A 5POS SMD
JP1, JP4	2	Würth Elektronik	61308021121	HDR2X5	CONN Header 5x2, 0.1 inch
JP2, JP3	2	Würth Elektronik	61304011121	HDR1X3	CONN HEADER 3POS 0.1 VERT GOLD
T9, T10, T11, T12	4				TEST POINT



XR77XXEVB-XCM-V80

XR77XX Configuration Module

EVALUATION BOARD LAYOUT

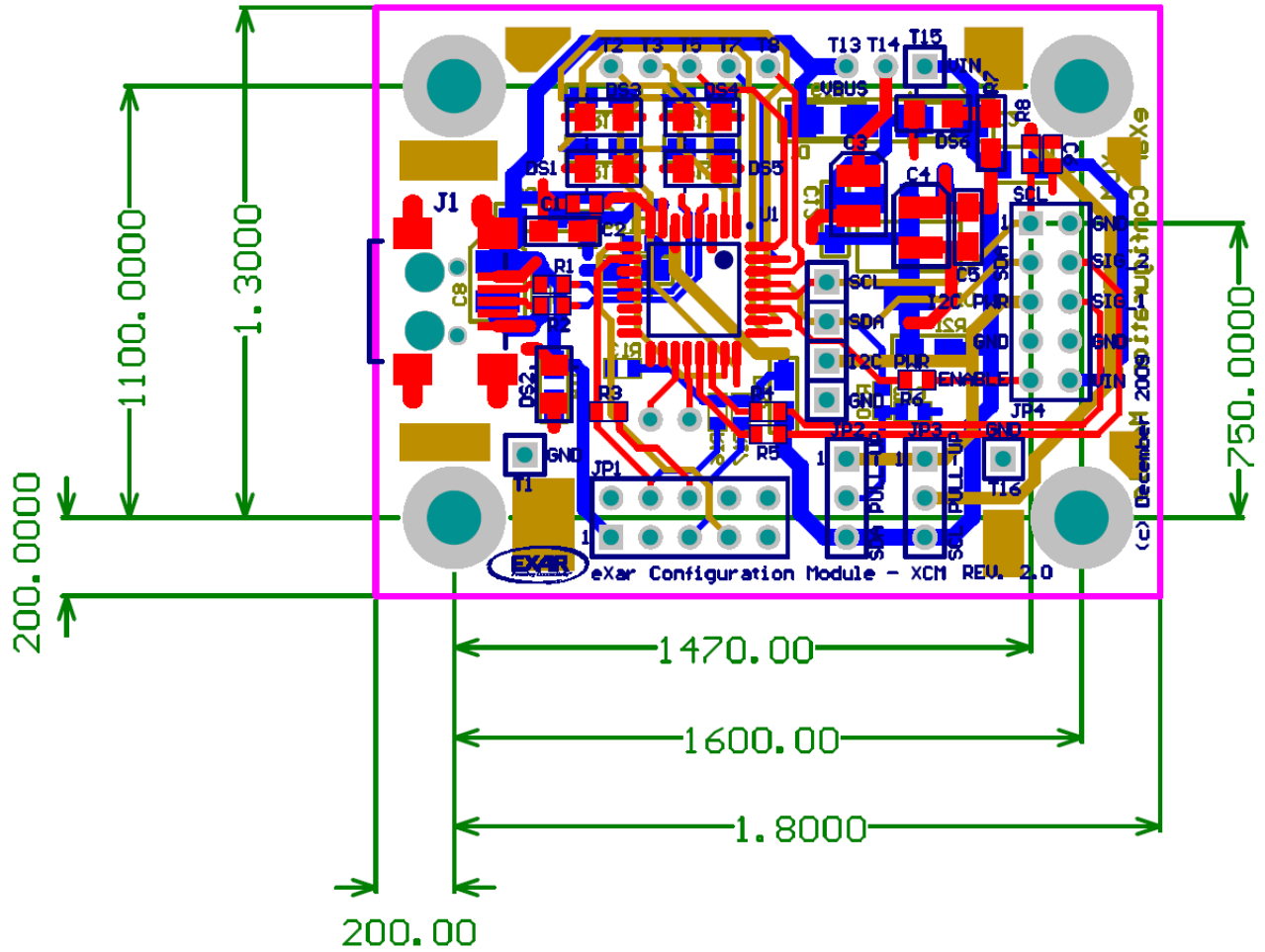



XR77XXEVB-XCM-V80

XR77XX Configuration Module

DOCUMENT REVISION HISTORY

Revision	Date	Description
1.0.0	04/26/2016	Initial release of document

BOARD REVISION HISTORY

Board Revision	Date	Description
2.0	Dec 2009	Initial release of evaluation board

FOR FURTHER ASSISTANCE

Email:

customersupport@exar.com

powertechsupport@exar.com

Exar Technical Documentation:

www.exar.com/technical-documentation



EXAR CORPORATION

HEADQUARTERS AND SALES OFFICES

48720 Kato Road

Fremont, CA 94538 – USA

Tel.: +1 (510) 668-7000

Fax: +1 (510) 668-7030

www.exar.com

NOTICE

EXAR Corporation reserves the right to make changes to the products contained in this publication in order to improve design, performance or reliability. EXAR Corporation assumes no responsibility for the use of any circuits described herein, conveys no license under any patent or other right, and makes no representation that the circuits are free of patent infringement. Charts and schedules contained here in are only for illustration purposes and may vary depending upon a user's specific application. While the information in this publication has been carefully checked; no responsibility, however, is assumed for inaccuracies.

EXAR Corporation does not recommend the use of any of its products in life support applications where the failure or malfunction of the product can reasonably be expected to cause failure of the life support system or to significantly affect its safety or effectiveness. Products are not authorized for use in such applications unless EXAR Corporation receives, in writing, assurances to its satisfaction that: (a) the risk of injury or damage has been minimized; (b) the user assumes all such risks; (c) potential liability of EXAR Corporation is adequately protected under the circumstances.

Reproduction, in part or whole, without the prior written consent of EXAR Corporation is prohibited.

X-ON Electronics

Largest Supplier of Electrical and Electronic Components

Click to view similar products for [Power Management IC Development Tools](#) category:

Click to view products by [MaxLinear](#) manufacturer:

Other Similar products are found below :

[EVB-EP5348UI](#) [MIC23451-AAAYFL EV](#) [MIC5281YMME EV](#) [124352-HMC860LP3E](#) [DA9063-EVAL](#) [ADP122-3.3-EVALZ](#) [ADP130-0.8-EVALZ](#) [ADP130-1.8-EVALZ](#) [ADP1740-1.5-EVALZ](#) [ADP1870-0.3-EVALZ](#) [ADP1874-0.3-EVALZ](#) [ADP199CB-EVALZ](#) [ADP2102-1.25-EVALZ](#) [ADP2102-1.875EVALZ](#) [ADP2102-1.8-EVALZ](#) [ADP2102-2-EVALZ](#) [ADP2102-3-EVALZ](#) [ADP2102-4-EVALZ](#) [AS3606-DB](#) [BQ25010EVM](#) [BQ3055EVM](#) [ISLUSBI2CKIT1Z](#) [LM2734YEVAL](#) [LP38512TS-1.8EV](#) [EVAL-ADM1186-1MBZ](#) [EVAL-ADM1186-2MBZ](#) [ADP122UJZ-REDYKIT](#) [ADP166Z-REDYKIT](#) [ADP170-1.8-EVALZ](#) [ADP171-EVALZ](#) [ADP1853-EVALZ](#) [ADP1873-0.3-EVALZ](#) [ADP198CP-EVALZ](#) [ADP2102-1.0-EVALZ](#) [ADP2102-1-EVALZ](#) [ADP2107-1.8-EVALZ](#) [ADP5020CP-EVALZ](#) [CC-ACC-DBMX-51](#) [ATPL230A-EK](#) [MIC23250-S4YMT EV](#) [MIC26603YJL EV](#) [MIC33050-SYHL EV](#) [TPS60100EVM-131](#) [TPS65010EVM-230](#) [TPS71933-28EVM-213](#) [TPS72728YFFEVM-407](#) [TPS79318YEQEV](#) [ISL85033EVAL2Z](#) [UCC28810EVM-002](#) [XILINXPWR-083](#)