



MXD8113H9

SP3T LNA for LTE mid-high band RX

This document contains information that is confidential and proprietary to Maxscend Microelectronics Company Limited (Maxscend) and may not be reproduced in any form without express written consent of Maxscend. No transfer or licensing of technology is implied by this document.

General Description

The MXD8113H9 is an FEM integrated with SP3T, LNA. The high linearity performance and low noise figure makes the device an ideal choice for LTE receiving applications.

The MXD8113H9 FEM is provided in a compact Quad Flat No-Lead (QFN) 1.15mm x 1.15mm x 0.45mm package. A functional block diagram is shown in Figure 1. The pin configuration and package are shown in Figure 2. Signal pin assignments and functional pin descriptions are provided in Table 1.

Applications

- LTE high-mid band receiving

Features

- Broadband frequency range: 1.7 to 2.7 GHz
- High Gain
 - 13dB gain at 1.7GHz to 2.3GHz
 - 12dB gain at 2.3GHz to 2.7GHz
- Low noise figure
 - 0.9dB noise figure at 1.7GHz to 2.3GHz
 - 1.1dB noise figure at 2.3GHz to 2.7GHz
- Input 1dB compression point -4dBm
- Operation current 6.5mA
- Small, LGA (9-pin, 1.15mm x 1.15mm x 0.45mm) package , MSL1

Functional Block Diagram and Pin Function

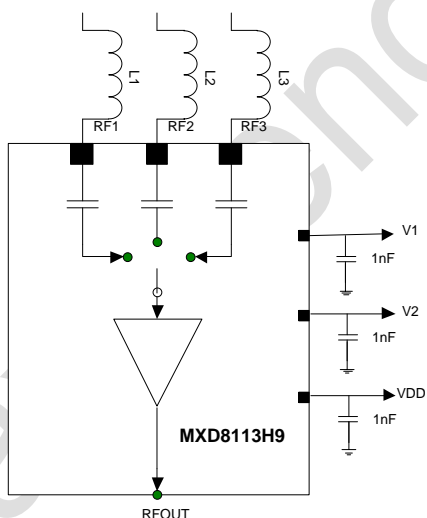

Figure 1. Functional Block Diagram

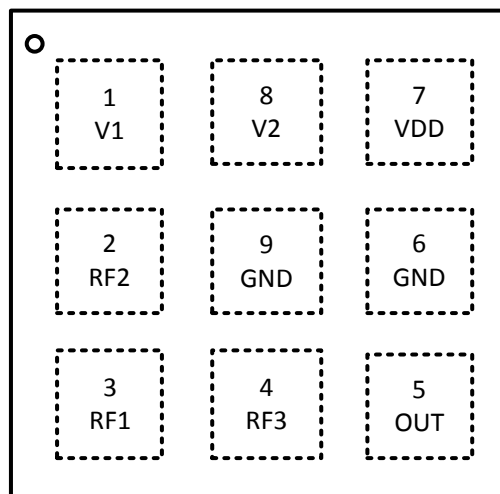

Figure 2. Pin-out (Top View)

Table 1. Pin Description

Pin No.	Name	Description	Pin No.	Name	Description
1	V1	Digital control 1#	6	GND	Ground
2	RF2	RF-Port 2	7	VDD	Power Supply
3	RF1	RF-Port 1	8	V2	Digital control 2#
4	RF3	RF-Port 3	9	GND	Ground
5	OUT	RF output			

Table 2 Input matching inductance

Component	Matching Band	Vendor	Type	Part Number & value
L1/L2/L3	1700MHz – 2300MHz	Murata	Wired inductor, high Q	LQW15AN6N2, 6.2nH
		various	Ceramic inductor, low Q	5.6nH
	2300MHz – 2700MHz	Murata	Wired inductor, high Q	LQW15AN5N1, 5.1nH
		various	Ceramic inductor, low Q	4.9nH

Truth Table
Table 3.

V1	V2	Active Path
1	0	RF1 active
0	1	RF2 active
1	1	RF3 active
0	0	Power down

Note: "1" = 1.0 V to 3.00 V. "0" = -0 V to +0.3 V.

Recommended Operation Range
Table 4.

Parameters	Symbol	Min	Typ	Max	Units
Operation Frequency	f1	1700	-	2700	MHz
Power supply	V _{DD}	2.5	2.8	3.0	V
Switch Control Voltage High	V _{CTL_H}	1.6	1.8	3.0	V
Switch Control Voltage Low	V _{CTL_L}	0	0	0.3	V

Specifications

Table 5. Electrical Specifications

Parameter	Symbol	Specification			Units	Test Condition
		Min.	Typical	Max.		
DC Specifications						
Control voltage: Low	V_{CTL_L}	0	0	0.3	V	
High	V_{CTL_H}	1.60	+1.8	3.00	V	
Supply voltage	V_{DD}	2.5	2.8	3.0	V	
Supply current	I_{DD}		6.5		mA	$V_{DD} = 2.8\text{ V}$
Power down current	I_{PD}		1		uA	
RF Specifications						
Power gain	G	11 10	13 12	14.5 13.5	dB dB	1700 to 2300MHz 2300 to 2700MHz
Noise figure	nf	- -	0.9 1.1	1.4 1.6	dB dB	1700 to 2300MHz 2300 to 2700MHz
Input Return loss	S11	-	-10	-6	dB	1700 to 2700MHz
Output Return loss	S22	-	-10	-6	dB	1700 to 2700MHz
Isolation(active gain - inactive gain)	ISO	25	30	-	dB	1700 to 2700MHz
Input 1 dB compression point	P1dB	-7 -4	-4 -1	- -	dBm dBm	1700 to 2300MHz 2300 to 2700MHz
Switching on time		-	2	3	us	50% VCTL to 10/90% RF
Switching off time		-	2	3	us	50% VCTL to 90/10% RF
Startup time		-	3	4	us	Shutdown state to any RF switch state

Absolute Maximum Ratings

Table 6. Maximum ratings

Parameters	Symbol	Minimum	Maximum	Units
Supply voltage	V_{DD}	+2.5	+3.3	V
Digital control voltage	V_{CTL}	0	+3.0	V
RF input power	P_{IN}	-	+10	dBm
Operating temperature	T_{OP}	-35	+90	°C
Storage temperature	T_{STG}	-55	+150	°C
Electrostatic discharge: Human Body Model (HBM), Class 1C	ESD	-	1500	V
Charged device model (CDM), Class III			1000	V

Note: Exposure to maximum rating conditions for extended periods may reduce device reliability. There is no damage to device with only one parameter set at the limit and all other parameters set at or below their nominal value. Exceeding any of the limits listed here may result in permanent damage to the device.

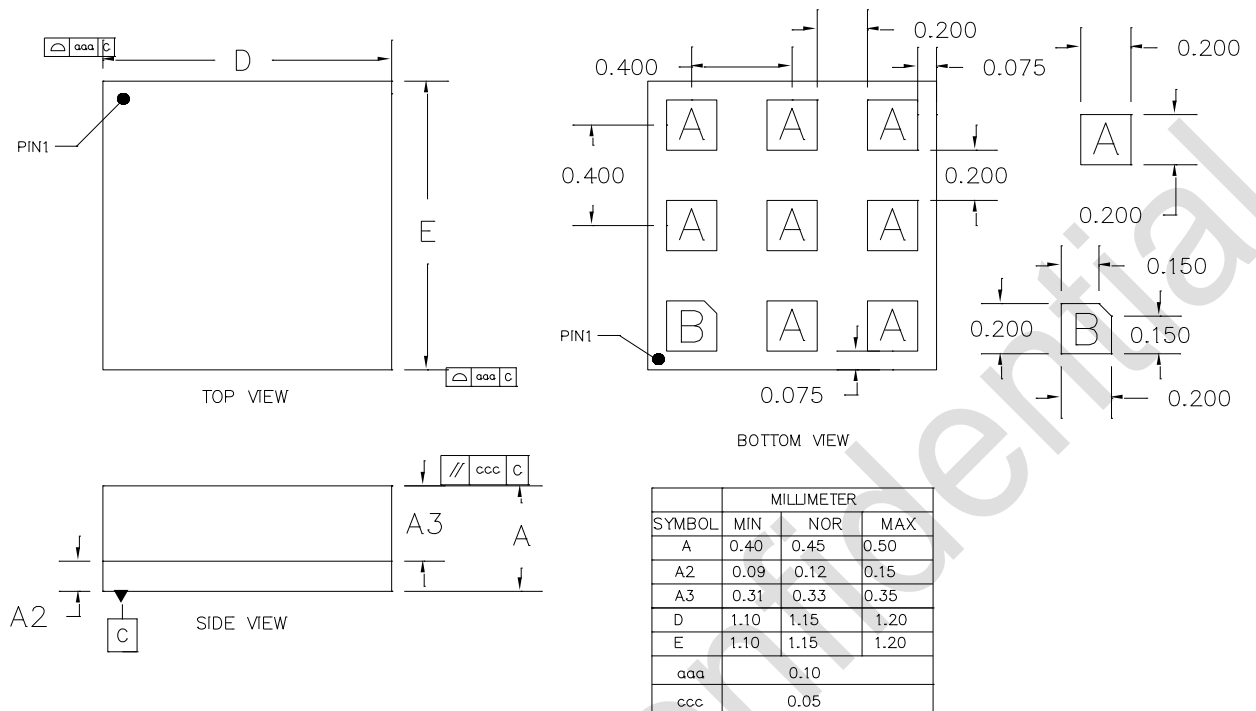
Package Outline Dimension

Figure 4. Package outline dimension

Marking Specification

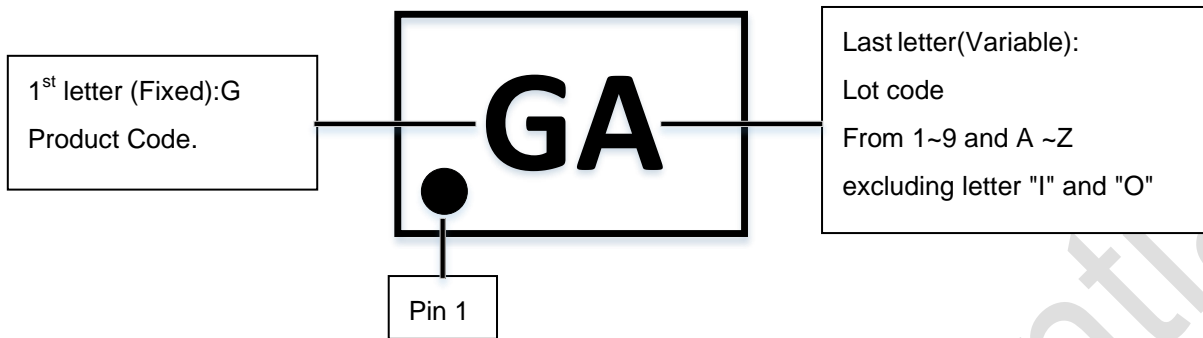
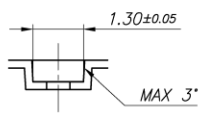
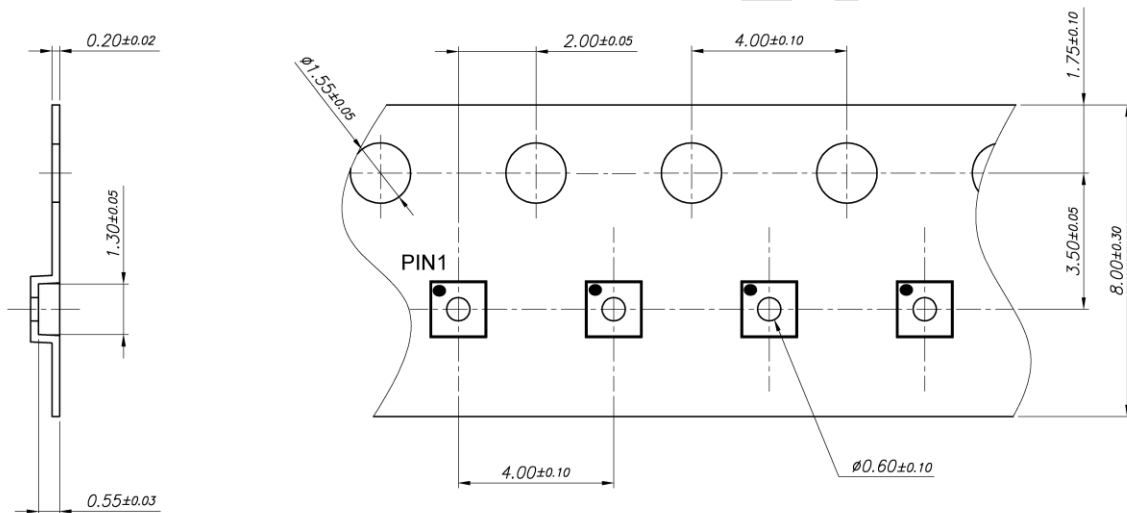

Figure 5. Marking specification (Top View)

Tape and Reel Dimensions



NOTES:

1. 10 sprocket hole pitch cumulative tolerance ± 0.2
2. Camber not to exceed 1mm in 250mm
3. Material: PolyCarbonate
4. K_0 measured from a plane on the inside bottom of the pocket to the top surface of the carrier.
5. Pocket position relative to sprocket hole measured as true position of pocket, not pocket hole.
6. Pocket center and pocket hole center must be same position.
7. ESD : 10E5 ~ 10E9

Figure 6. Tape and reel dimensions

Reflow Chart

Figure 7. Recommended Lead-Free Reflow Profile

Table 7. Reflow condition

Profile Parameter	Lead-Free Assembly, Convection, IR/Convection
Ramp-up rate ($T_{S_{max}}$ to T_P)	3°C/second max.
Preheat temperature ($T_{S_{min}}$ to $T_{S_{max}}$)	150°C to 200°C
Preheat time (t_s)	60 - 180 seconds
Time above T_L , 217°C (t_L)	60 - 150 seconds
Peak temperature (T_P)	260°C
Time within 5°C of peak temperature(t_p)	20 - 40 seconds
Ramp-down rate	6°C/second max.
Time 25°C to peak temperature	8 minutes max.

ESD Sensitivity

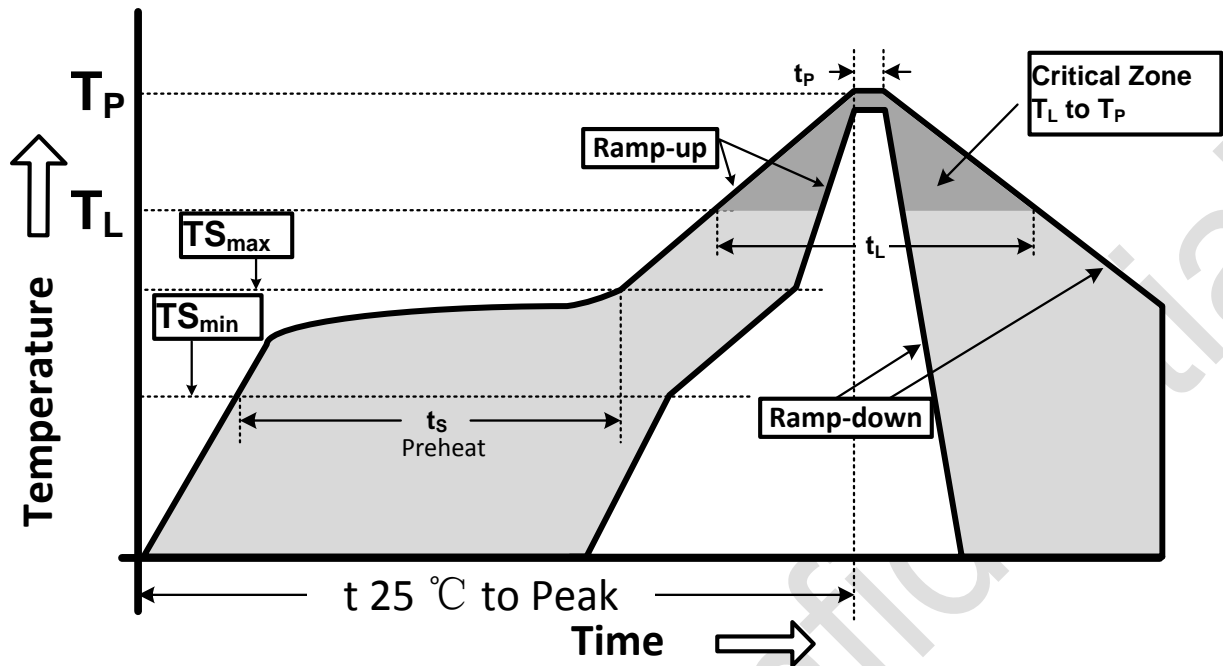
Integrated circuits are ESD sensitive and can be damaged by static electric charge. Proper ESD protection techniques should be used when handling these devices.

RoHS Compliant

This product does not contain lead, mercury, cadmium, hexavalent chromium, polybrominated biphenyls (PBB) and polybrominated diphenyl ethers (PBDE), and are considered RoHS compliant.

1.02

X-ON Electronics

Largest Supplier of Electrical and Electronic Components

Click to view similar products for [Operational Amplifiers - Op Amps](#) category:

Click to view products by [Maxscend](#) manufacturer:

Other Similar products are found below :

[OPA2991IDSGR](#) [OPA607IDCKT](#) [007614D](#) [633773R](#) [635798C](#) [635801A](#) [702115D](#) [709228FB](#) [741528D](#) [NCV33072ADR2G](#)
[SC2902DTBR2G](#) [SC2903DR2G](#) [SC2903VDR2G](#) [LM258AYDT](#) [LM358SNG](#) [430227FB](#) [430228DB](#) [460932C](#) [AZV831KTR-G1](#) [409256CB](#)
[430232AB](#) [LM2904DR2GH](#) [LM358YDT](#) [LT1678IS8](#) [042225DB](#) [058184EB](#) [070530X](#) [SC224DR2G](#) [SC239DR2G](#) [SC2902DG](#)
[SCYA5230DR2G](#) [714228XB](#) [714846BB](#) [873836HB](#) [MIC918YC5-TR](#) [TS912BIYDT](#) [NCS2004MUTAG](#) [NCV33202DMR2G](#)
[M38510/13101BPA](#) [NTE925](#) [SC2904DR2G](#) [SC358DR2G](#) [LM358EDR2G](#) [AZV358MTR-G1](#) [AP4310AUMTR-AG1](#) [HA1630D02MMEL-E](#)
[NJM358CG-TE2](#) [HA1630S01LPEL-E](#) [LM324AWPT](#) [HA1630Q06TELL-E](#)