



MXDLN02C

FM Low Noise Amplifier

This document contains information that is confidential and proprietary to Maxscend Microelectronics Company Limited (Maxscend) and may not be reproduced in any form without express written consent of Maxscend. No transfer or licensing of technology is implied by this document.

General Description

MXDLN02C low current, high gain, low noise amplifier (LNA) is dedicated to FM receive. This product achieved excellent noise figure of 1.3dB and 23dB gain.

MXDLN02C works under a 2.5V to 3.3V single power supply while consumes 10 mA current, in power down (PD) mode, the power consumption will be reduced to less than 0.1uA.

MXDLN02C uses a small 2.1mmx2.3mmx0.95mm SOT363 6-pin package.

Features

- Low noise figure: 1.3 dB
- High gain: 23dB
- PD current less than 0.1uA
- Single supply voltage range 2.5V to 3.3V
- Small package 2.1mmx2.3mmx0.95mm
- Low cost BOM
- Lead-Free and RoHS-Compliant

Applications

Cell Phone with FM
Portable audio device

Pin Configuration and function block diagram (Top view)

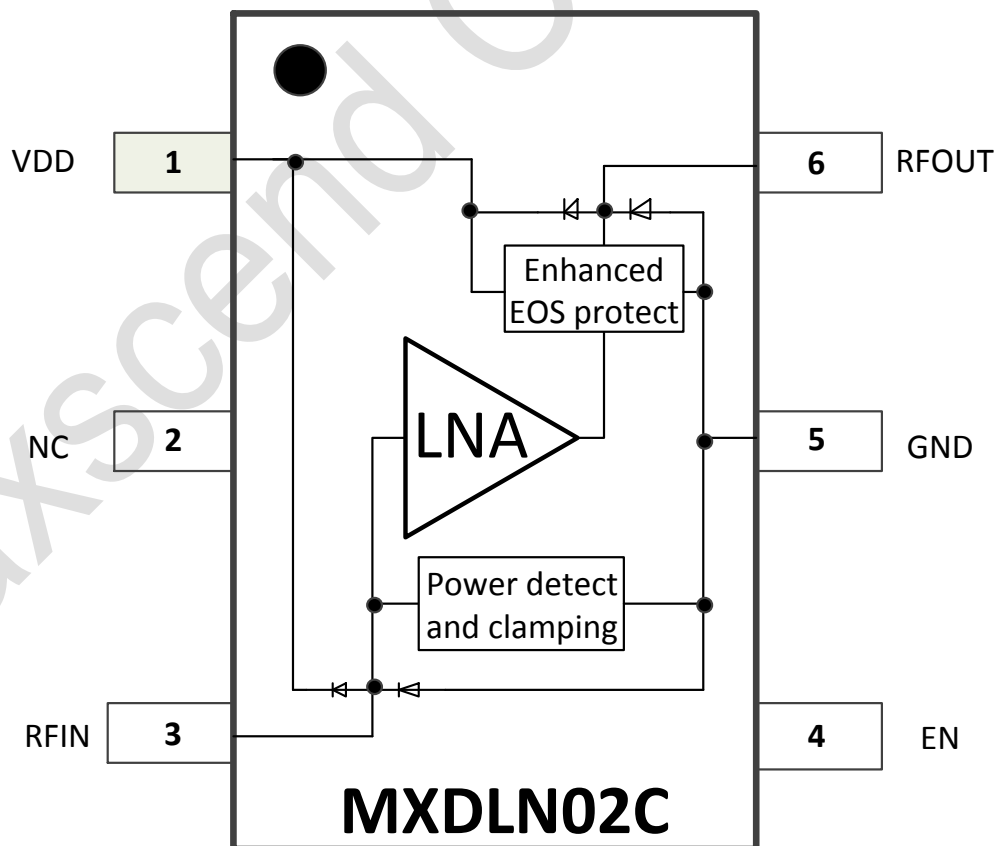


Figure 1 MXDLN02C pin configuration and function block diagram

Application circuit

Application A: Internal antenna;

Application B: Separated antenna, matching to 50 Ohm.

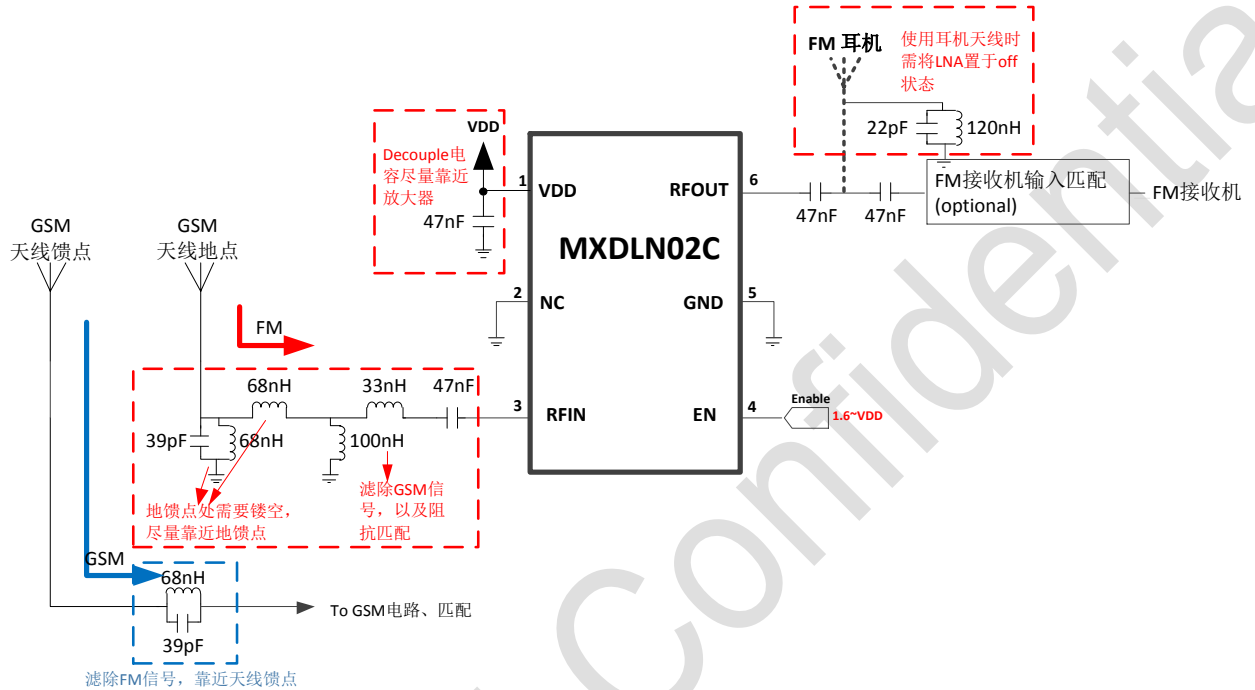


Figure 2 Application A: Internal antenna sharing with GSM

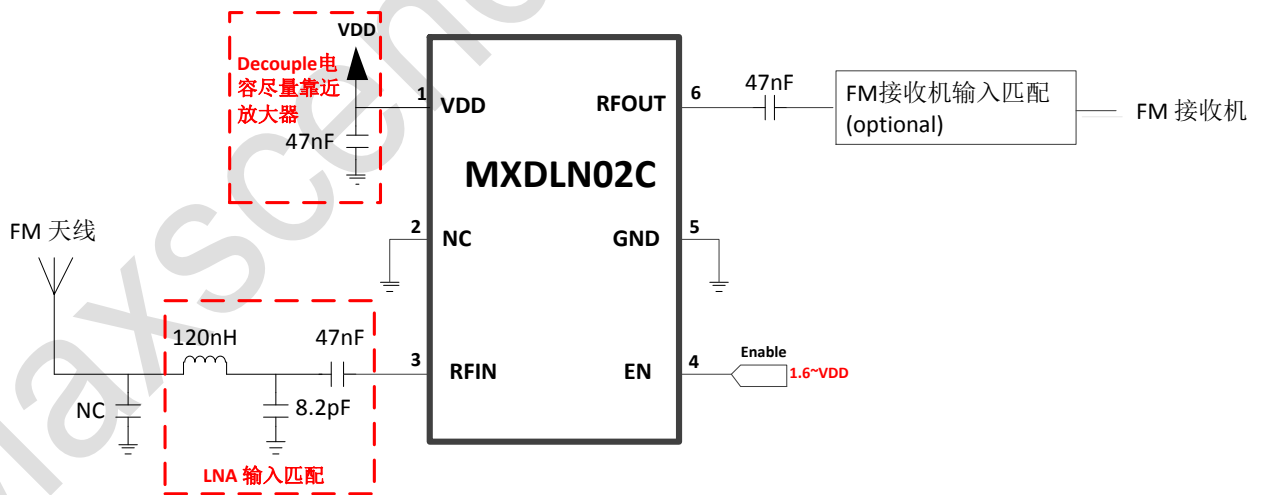


Figure 3 Application B: Separated antenna

Pin Descriptions

Table 1. Pin Descriptions

Pin	Pin Name	I/O	Pin Description
1	VDD	AP	Power supply
2	NC	-	-
3	RFIN	AI	LNA input from antenna
4	EN	DI	Pull high enable, pull low into power down mode
5	GND	AG	Analog VSS
6	RFOUT	AO	LNA output

Note: *DI* (digital input), *DO* (digital output), *DIO* (digital bidirectional), *AI* (analog input), *AO* (analog output), *AIO* (analog bidirectional), *AP* (analog power), *AG* (analog ground)

Absolute Maximum Ratings

Table 2.

Parameters	Range	Units
Power supply	-0.3 ~ 3.8	V
Other Pin to GND	-0.3~VDD+0.3	V
Maximum RF Input Power	25	dBm
Operation Temperature Range	-40~85	°C
Junction Temperature	150	°C
Storage temperature Range	-65~160	°C
Lead Temperature (soldering)	260	°C
Soldering Temperature (reflow)	260	°C
Human Body Mode ESD	-2000~+2000	V
Charge Device Mode ESD	-500~+500	V

Specifications

DC Characteristics

Typically $T_A=25^{\circ}\text{C}$ VDD=2.8V, VEN=1.8V, unless otherwise noted

Table 3.

Parameters	Condition	Min	Typ	Max	Units
Supply Voltage		2.5	2.8	3.3	V
Supply Current	EN=High		10		mA
EN Input High		1.6	1.8	VDD	V
EN Input Low		0	0	0.3	V

AC Characteristics

 Typically $T_A=25^{\circ}\text{C}$ $V_{DD}=2.8\text{V}$, $V_{EN}=1.8\text{V}$, all data measured on Maxscend's EVB, unless otherwise noted

Table 4. AC Specifications, no any matching network, 50 Ohm port

Parameters	Conditions	Min	Typ	Max	Units
RF Frequency Range		50		150	MHz
Operation Current			10		mA
Power Down Current				0.1	μA
Power Gain	Note1		23		dB
Input Power 1-dB Compression Point			-20		dBm
Noise Figure	Note1		1.3		dB
Input Return Loss	Note1		-3.2		dB
Output Return Loss	Note1		-4.5		dB
Reverse Isolation	Note1		-50		dB
Stability	Note1	2			N/A

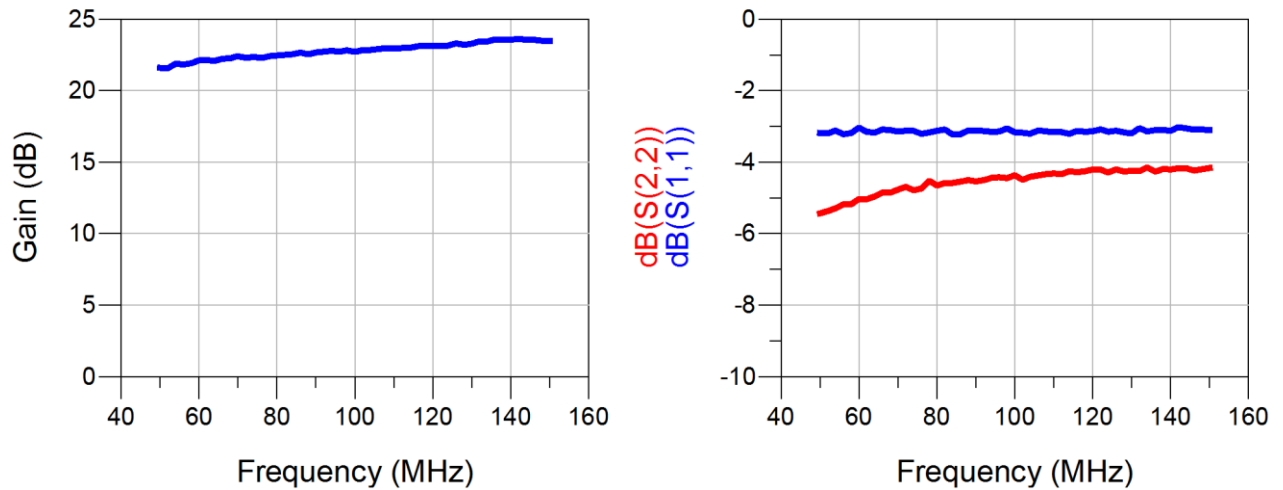
Note1: measuring at 50 Ohm load


Figure 4 Power Gain & Input/output return loss

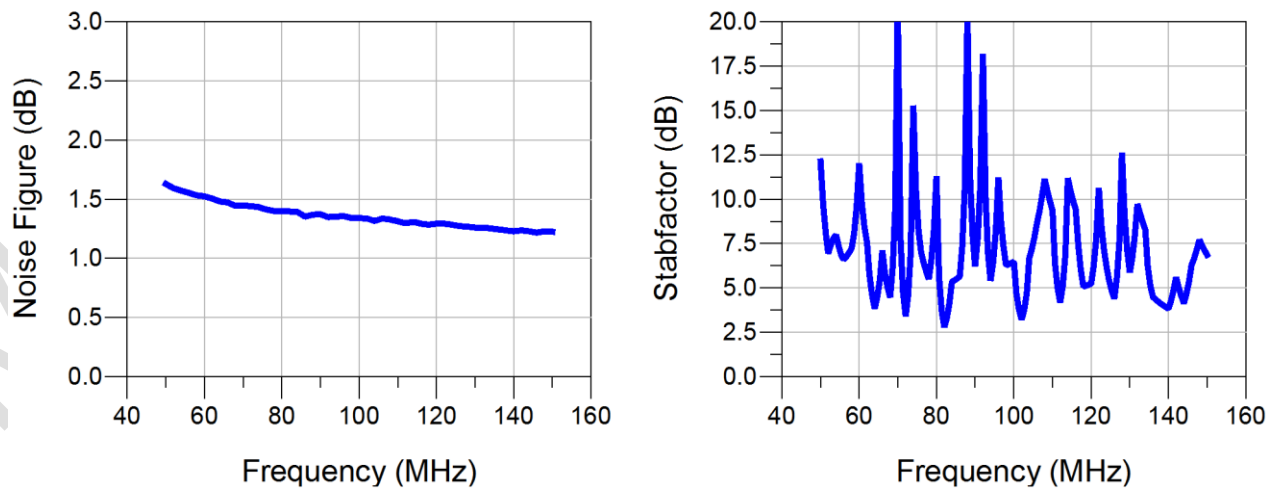


Figure 5 Noise Figure & Stability factor

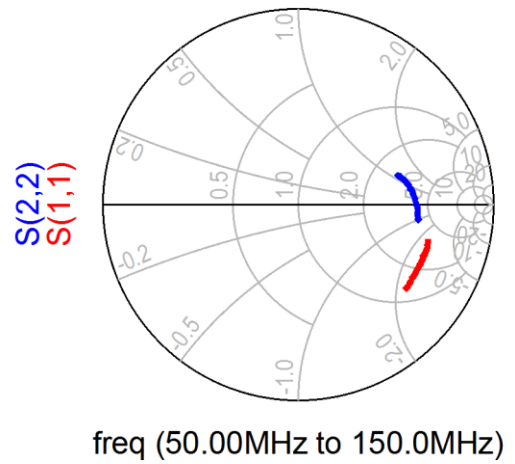
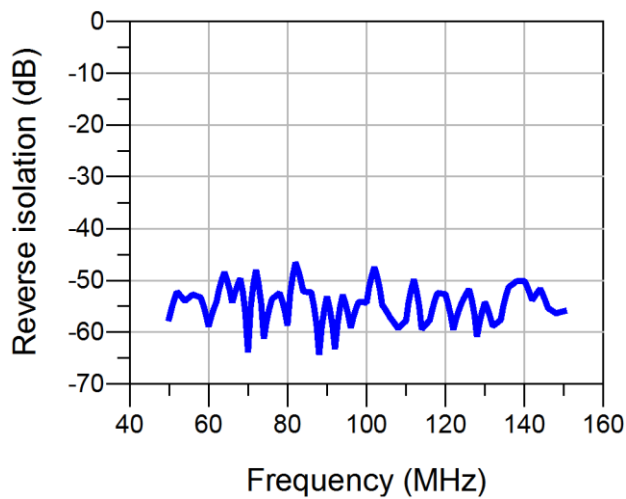


Figure 6 Reverse isolation & Smith chart

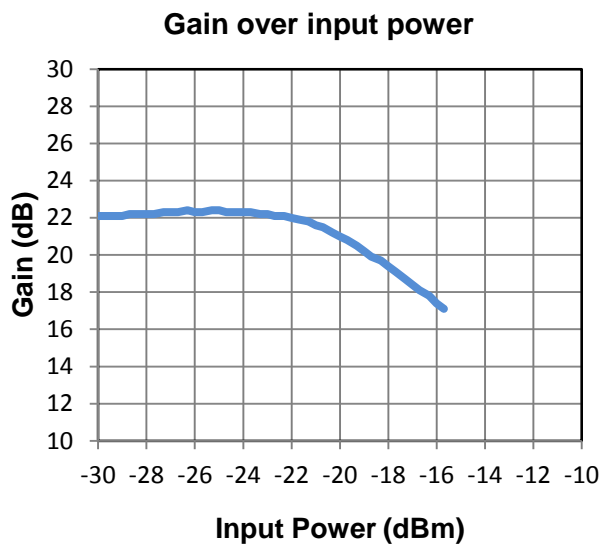
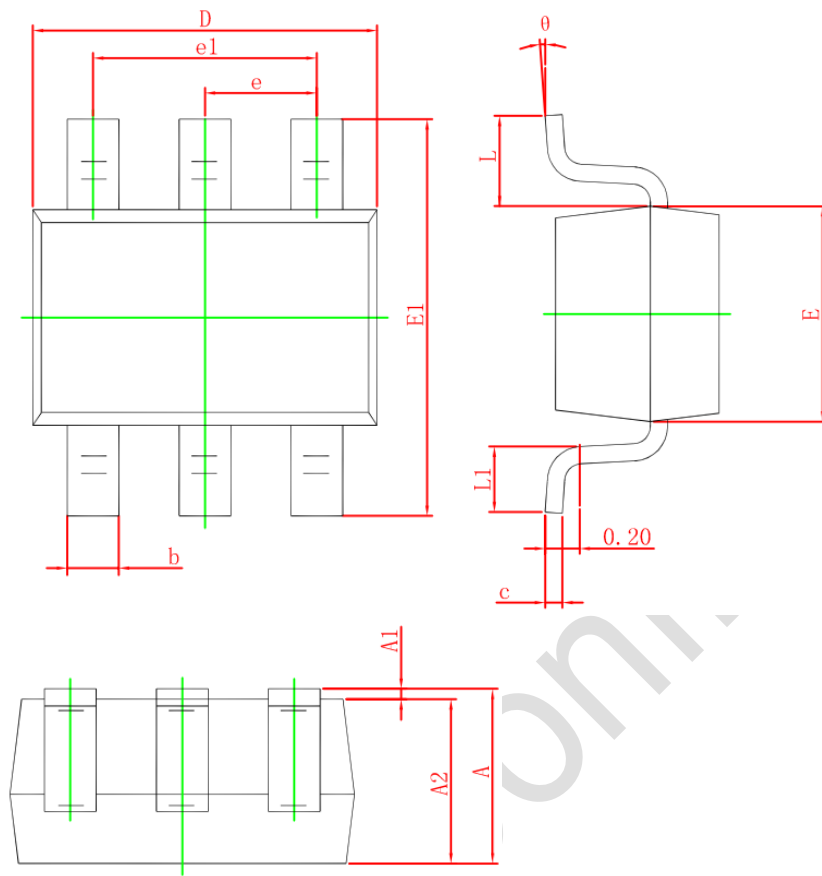


Figure 7 Gain curve over input power

Package Outline Dimensions


Symbol	Dimensions In Millimeters		Dimensions In Inches	
	Min.	Max.	Min.	Max.
A	0.900	1.100	0.035	0.043
A1	0.000	0.100	0.000	0.004
A2	0.900	1.000	0.035	0.039
b	0.150	0.350	0.006	0.014
c	0.080	0.150	0.003	0.006
D	2.000	2.200	0.079	0.087
E	1.150	1.350	0.045	0.053
E1	2.150	2.450	0.085	0.096
e	0.650 TYP.		0.026 TYP.	
e1	1.200	1.400	0.047	0.055
L	0.525 REF.		0.021 REF.	
L1	0.260	0.460	0.010	0.018
θ	0°	8°	0°	8°

Figure 8 MXDLN02C outline dimension

Reflow Chart

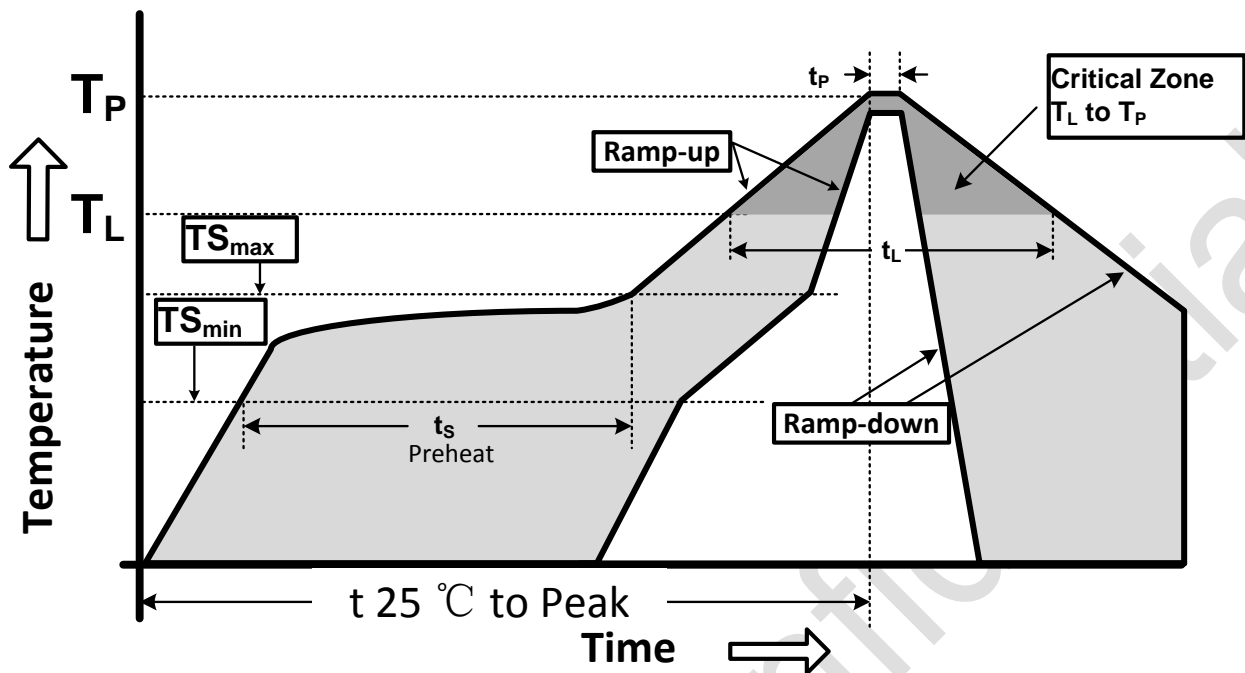


Figure 9 Recommended Lead-Free Reflow Profile

Table 5. Reflow condition

Profile Parameter	Lead-Free Assembly, Convection, IR/Convection
Ramp-up rate (TS_{max} to T_p)	3°C/second max.
Preheat temperature (TS_{min} to TS_{max})	150°C to 200°C
Preheat time (t_s)	60 - 180 seconds
Time above T_L , 217°C (t_L)	60 - 150 seconds
Peak temperature (T_p)	260°C
Time within 5°C of peak temperature(t_p)	20 - 40 seconds
Ramp-down rate	6°C/second max.
Time 25°C to peak temperature	8 minutes max.

ESD Sensitivity

Integrated circuits are ESD sensitive and can be damaged by static electric charge. Proper ESD protection techniques should be used when handling these devices.

RoHS Compliant

This product does not contain lead, mercury, cadmium, hexavalent chromium, polybrominated biphenyls (PBB) and polybrominated diphenyl ethers (PBDE), and are considered RoHS compliant.

1.5.1

X-ON Electronics

Largest Supplier of Electrical and Electronic Components

Click to view similar products for [Operational Amplifiers - Op Amps](#) category:

Click to view products by [Maxscend](#) manufacturer:

Other Similar products are found below :

[LM358SNG](#) [430227FB](#) [AZV831KTR-G1](#) [LT1678IS8](#) [042225DB](#) [058184EB](#) [SC2902DG](#) [UPC822G2-A](#) [UPC258G2-A](#) [MIC918YC5-TR](#)
[NCS5651MNTXG](#) [NCV33202DMR2G](#) [NJM324E](#) [NTE925](#) [5962-9080901MCA*](#) [AP4310AUMTR-AG1](#) [HA1630D02MMEL-E](#)
[HA1630S01LPEL-E](#) [SCY33178DR2G](#) [NJU77806F3-TE1](#) [NCV5652MUTWG](#) [NCV20034DR2G](#) [LM2902EDR2G](#) [NTE778S](#) [NTE871](#)
[NTE924](#) [NTE937](#) [MCP6V16UT-E/OT](#) [MCP6V17T-E/MS](#) [MCP6V19T-E/ST](#) [SCY6358ADR2G](#) [LTC2065IUD#PBF](#) [NCS20282FCTTAG](#)
[UPC4741G2-E1-A](#) [LM4565FVT-GE2](#) [EL5420CRZ-T7A](#) [TSV791IYLT](#) [TSV772IQ2T](#) [AS324AMTR-E1](#) [TLV2772QPWR](#) [NJM4556AM-TE1](#) [NJM2068M-TE1](#) [AS324MTR-E1](#) [AS358MMTR-G1](#) [MCP6232T-EMNY](#) [MCP662-E/MF](#) [TLC081AIP](#) [TLC082AIP](#) [TLE2074ACDW](#)
[TLV07IDR](#)