



MXDLN14TP

**SiGe Low Noise Amplifier
for Dual-Band GNSS Applications**

Rev 1.2

This document contains information that is confidential and proprietary to Maxscend Microelectronics Company Limited (Maxscend) and may not be reproduced in any form without express written consent of Maxscend. No transfer or licensing of technology is implied by this document.

General Description

MXDLN14TP high gain, Dual-Band low noise amplifier (LNA) is dedicated to GPS, GLONASS Galileo and Beidou standards. This product has an extremely low noise figure of 0.5dB, 18.2dB gain and excellent linearity.

MXDLN14TP works under a 1.6V to 3.6V single power supply while consumes 3.3 mA current, in power down (PD) mode, the power consumption will be reduced to less than 1uA.

MXDLN14TP uses a small 1.1mm x 0.7mm x 0.45mm LGA 6-pin package.

Applications

Automotive Navigation
 Personal Navigation Device (PND)
 Cell Phone with GPS
 MID/PAD with GPS

Features

- High Gain:
 - 18.0dB @ 1176.45MHz
 - 18.2dB @ 1227.6MHz
 - 17.5dB @ 1575.42MHz
- Low noise figure:
 - 0.60dB @ 1176.45MHz
 - 0.60dB @ 1227.6MHz
 - 0.50dB @ 1575.42MHz
- Low operation current 3.3mA & PD current less than 1uA
- Single supply voltage range 1.6V to 3.6V
- Small package 1.1mmx0.7mmx0.45mm , MSL1
- Low cost BOM
- Lead-Free and RoHS-Compliant

Pin Configuration/Application Diagram (Top view)

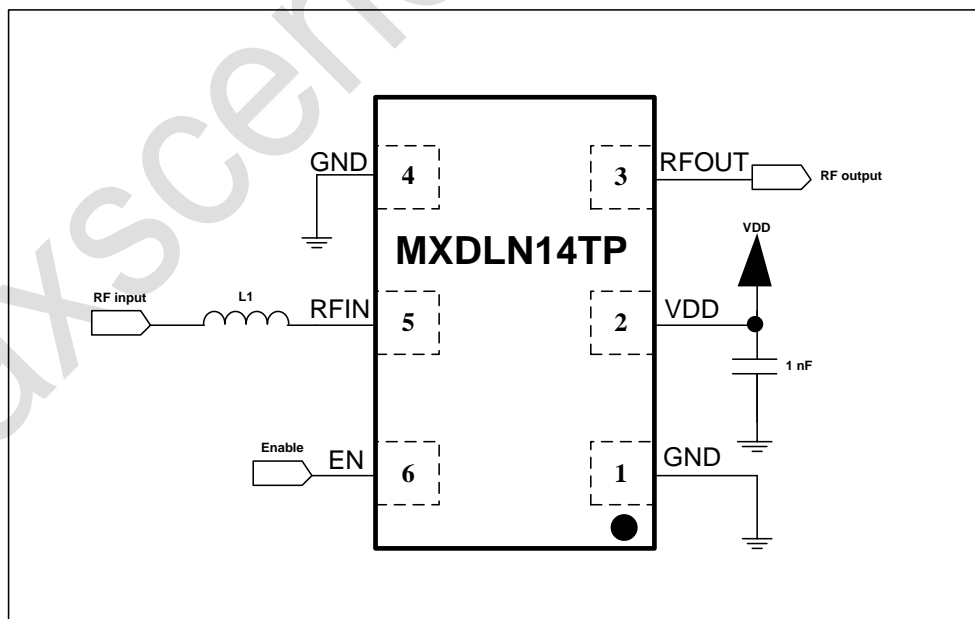

Figure 1.MXDLN14TP application circuit

Table 1.

Component	Matching Band	Vendor	Type	Part Number & value
L1	1160-1300MHz	Murata	Wired inductor, high Q	LQW15AN12N, 12nH
		various	Ceramic inductor, low Q	11nH
L1	1550-1615MHz	Murata	Wired inductor, high Q	LQW15AN6N8, 6.8nH
		various	Ceramic inductor, low Q	6.2nH

Absolute Maximum Ratings

Table 2.

Parameters	Range	Units
Power supply	-0.3 ~ 4.0	V
Other Pin to GND	-0.3~VDD+0.3	V
Maximum RF Input Power	25	dBm
Operation Temperature Range	-40~90	°C
Junction Temperature	150	°C
Storage temperature Range	-65~160	°C
Lead Temperature (soldering)	260	°C
Soldering Temperature (reflow)	260	°C
Human Body Mode ESD	-2000~+2000	V
Machine Mode ESD	-150~+150	V
Charge Device Mode ESD	-1000~+1000	V

Specifications

DC Characteristics

$T_A = -40 \sim +90^\circ\text{C}$, Typically $T_A = 25^\circ\text{C}$ VDD=2.8V, unless otherwise noted

Table 3.

Parameters	Condition	Min	Typ	Max	Units
Supply Voltage		1.6	2.8	3.6	V
Supply Current	VDD=1.6~3.6V EN=High,	-	3.3	-	mA
	EN=Low	0	0.01	1	uA
EN Input High		1.0	1.8	VDD	V
EN Input Low		0	0	0.3	V

AC Characteristics
 $T_A = -40 \sim +90^\circ\text{C}$, typically $T_A = 25^\circ\text{C}$ $V_{DD} = 2.8\text{V}$, all data measured on Maxscend's EVB, unless otherwise noted

Table 4.

Parameters	Conditions	Min	Typ	Max	Units
RF Frequency Range	None	1160	1176.45	1215	MHz
Power Gain		-	18.0	-	dB
Noise Figure		-	0.6	1.0	dB
Input Return Loss	Note1	-	-9	-5	dB
Output Return Loss	Note1	-	-9	-5	dB
Reverse Isolation	Note1	-	-29	-24	dB
Stability	Note2	1.5	-	-	
Input Power 1-dB Compression Point	1176MHz	-13	-9.5	-	dBm
Input In-Band IP3	Note3	-7	-2	-	dBm
Output In-Band IP3	Note4	-2	3	-	dBm

 $T_A = -40 \sim +90^\circ\text{C}$, typically $T_A = 25^\circ\text{C}$ $V_{DD} = 1.8\text{V}$, all data measured on Maxscend's EVB, unless otherwise noted

Table 5.

Parameters	Conditions	Min	Typ	Max	Units
RF Frequency Range	None	1160	1176.45	1215	MHz
Power Gain		-	17.8	-	dB
Noise Figure		-	0.6	1.0	dB
Input Return Loss	Note1	-	-9	-5	dB
Output Return Loss	Note1	-	-9	-5	dB
Reverse Isolation	Note1	-	-29	-24	dB
Stability	Note2	1.5	-	-	
Input Power 1-dB Compression Point	1176MHz	-16	-12.5	-	dBm
Input In-Band IP3	Note3	-9	-4	-	dBm
Output In-Band IP3	Note4	-4	1	-	dBm

Note1: sweep power -30dBm, 1176.45MHz

Note2: frequency range 500MHz-5GHz

Note3: $f_1 = 1175.45\text{ MHz}$, $f_2 = 1176.45\text{ MHz}$, -25dBm

Note4: $f_1 = 1800\text{ MHz}$, $f_2 = 2400\text{ MHz}$, $pin = -20\text{ dBm}$ at f_1 , $pin = -65\text{ dBm}$ at f_2

AC Characteristics

T_A=-40~+90°C, typically T_A=25°C VDD=2.8V, all data measured on Maxscend's EVB, unless otherwise noted

Table 6.

Parameters	Conditions	Min	Typ	Max	Units
RF Frequency Range	None	1215	1227.6	1300	MHz
Power Gain		-	18.2	-	dB
Noise Figure		-	0.6	1.0	dB
Input Return Loss	Note1	-	-10	-5	dB
Output Return Loss	Note1	-	-10	-5	dB
Reverse Isolation	Note1	-	-28	-23	dB
Stability	Note2	1.5	-	-	
Input Power 1-dB Compression Point	1227MHz	-13	-9.5	-	dBm
Input In-Band IP3	Note3	-7	-2	-	dBm
Output In-Band IP3	Note4	-2	3	-	dBm

T_A=-40~+90°C, typically T_A=25°C VDD=1.8V, all data measured on Maxscend's EVB, unless otherwise noted

Table 7.

Parameters	Conditions	Min	Typ	Max	Units
RF Frequency Range	None	1215	1227.6	1300	MHz
Power Gain		-	18.0	-	dB
Noise Figure		-	0.6	1.0	dB
Input Return Loss	Note1	-	-10	-5	dB
Output Return Loss	Note1	-	-10	-5	dB
Reverse Isolation	Note1	-	-28	-23	dB
Stability	Note2	1.5	-	-	
Input Power 1-dB Compression Point	1227MHz	-16	-12.5	-	dBm
Input In-Band IP3	Note3	-9	-4	-	dBm
Output In-Band IP3	Note4	-4	1	-	dBm

Note1: sweep power -30dBm, 1227.6MHz

Note2: frequency range 500MHz-5GHz

Note3: f₁ = 1226.6 MHz, f₂ = 1227.6 MHz, -25dBm

Note4: f₁=1800MHz, f₂=2400MHz, pin= -20dBm at f₁, pin= -65dBm at f₂

T_A=-40~+90°C, typically T_A=25°C VDD=2.8V, all data measured on Maxscend's EVB, unless otherwise noted

Table 8.

Parameters	Conditions	Min	Typ	Max	Units
RF Frequency Range	None	1550	1575.42	1615	MHz
Power Gain		-	17.5	-	dB
Noise Figure		-	0.5	0.9	dB
Input Return Loss	Note1	-	-15	-10	dB
Output Return Loss	Note1	-	-15	-10	dB
Reverse Isolation	Note1	-	-26	-21	dB
Stability	Note2	1.5	-	-	
Input Power 1-dB Compression Point	1575MHz	-11	-7	-	dBm
Input In-Band IP3	Note3	-5	0	-	dBm
Output In-Band IP3	Note4	0	5	-	dBm

T_A=-40~+90°C, typically T_A=25°C VDD=1.8V, all data measured on Maxscend's EVB, unless otherwise noted

Table 9.

Parameters	Conditions	Min	Typ	Max	Units
RF Frequency Range	None	1550	1575.42	1615	MHz
Power Gain		-	17.3	-	dB
Noise Figure		-	0.5	0.9	dB
Input Return Loss	Note1	-	-15	-10	dB
Output Return Loss	Note1	-	-15	-10	dB
Reverse Isolation	Note1	-	-26	-21	dB
Stability	Note2	1.5	-	-	
Input Power 1-dB Compression Point	1575MHz	-13.5	-10	-	dBm
Input In-Band IP3	Note3	-7	-2	-	dBm
Output In-Band IP3	Note4	-2	3	-	dBm

Note1: sweep power -30dBm, 1575.42MHz

Note2: frequency range 500MHz-5GHz

Note3: f1 = 1574.42 MHz, f2 = 1575.42 MHz, -25dBm

Note4: f1=1713MHz, f2=1851MHz, pin= -20dBm at f1, pin= -65dBm at f2

Pin Descriptions

Table 10.

Pin	Pin Name	I/O	Pin Description
1	GND	AG	Analog VSS
2	VDD	AP	Power supply
3	RFOUT	AO	LNA output
4	GND	AG	Analog VSS
5	RFIN	AI	LNA input from antenna
6	EN	DI	Pull high enable, pull low into power down mode

Note: DI (digital input), DO (digital output), DIO (digital bidirectional), AI (analog input), AO (analog output), AIO (analog bidirectional), AP (analog power), AG (analog ground),

Outline Dimensions

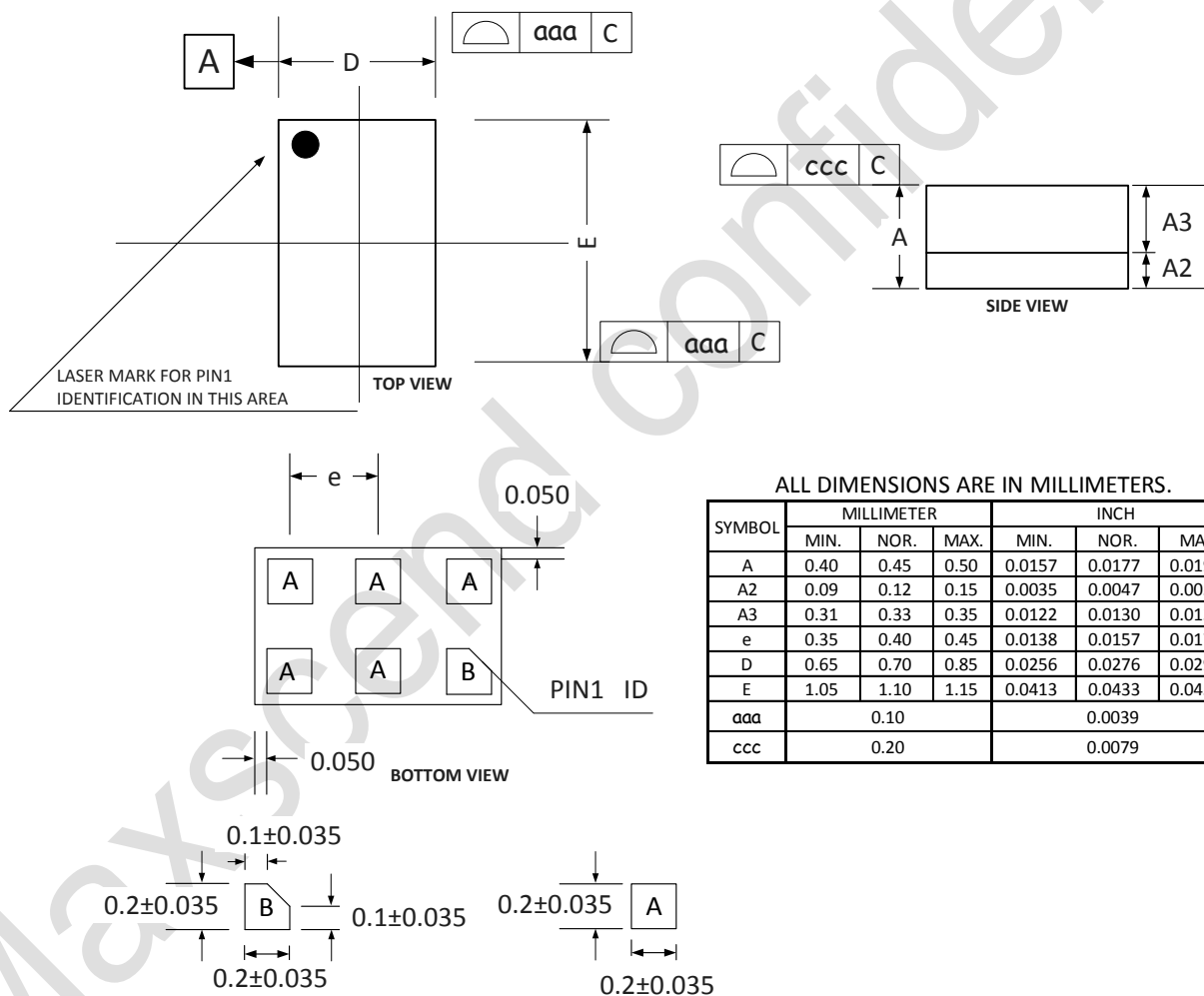

Figure 2. MXDLN14TP outline dimension

Marking Specification

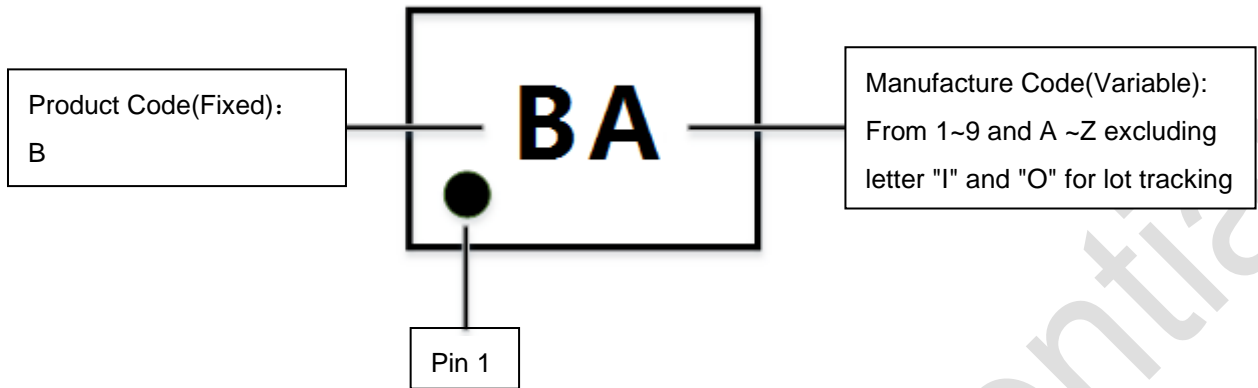

Figure 3. Marking specification (Top View)

Tape and Reel Dimensions

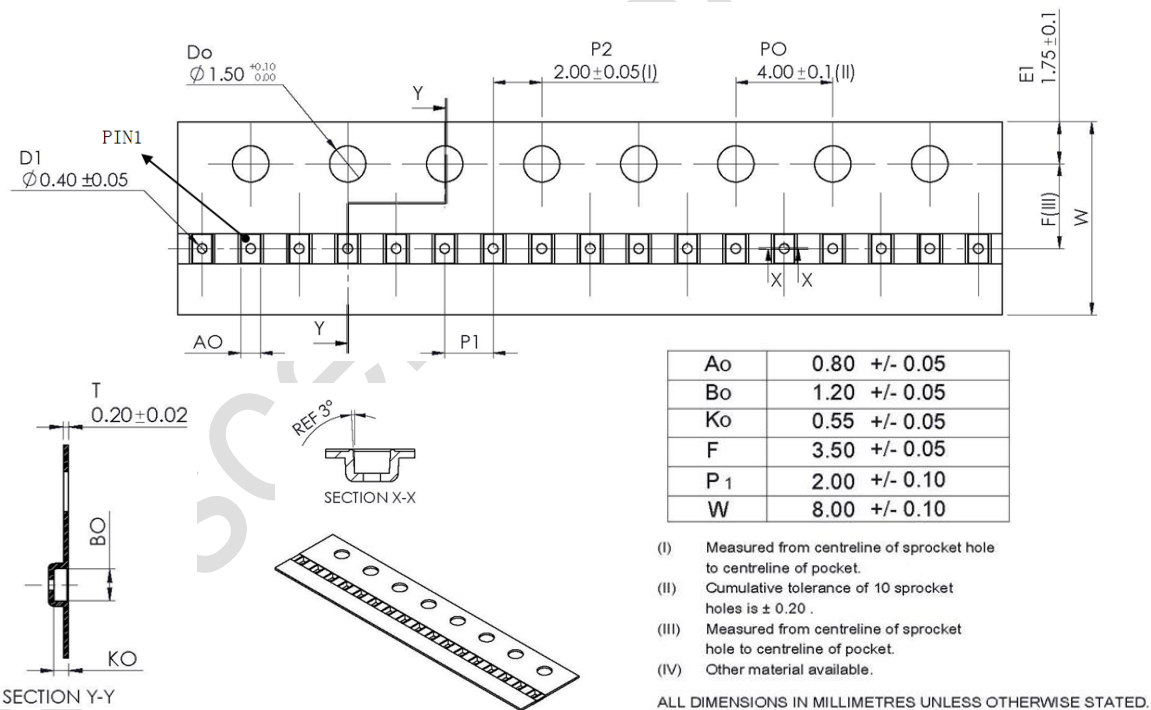

Figure 4. Tape and reel dimensions

Reflow Chart

Figure 5. Recommended Lead-Free Reflow Profile

Table 11.

Profile Parameter	Lead-Free Assembly, Convection, IR/Convection
Ramp-up rate (TS_{max} to T_p)	3°C/second max.
Preheat temperature (TS_{min} to TS_{max})	150°C to 200°C
Preheat time (t_s)	60 - 180 seconds
Time above T_L , 217°C (t_L)	60 - 150 seconds
Peak temperature (T_p)	260°C
Time within 5°C of peak temperature (t_p)	20 - 40 seconds
Ramp-down rate	6°C/second max.
Time 25°C to peak temperature	8 minutes max.

ESD Sensitivity

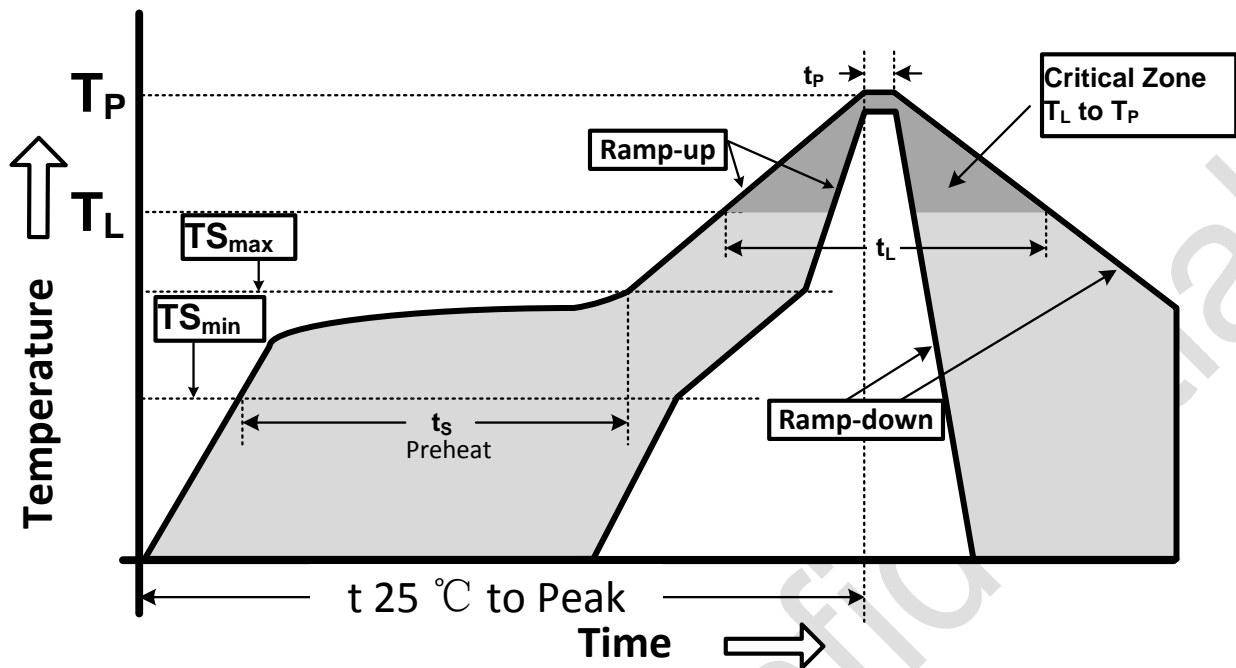
Integrated circuits are ESD sensitive and can be damaged by static electric charge. Proper ESD protection techniques should be used when handling these devices.

RoHS Compliant

This product does not contain lead, mercury, cadmium, hexavalent chromium, polybrominated biphenyls (PBB) and polybrominated diphenyl ethers (PBDE), and are considered RoHS compliant.

X-ON Electronics

Largest Supplier of Electrical and Electronic Components

Click to view similar products for [Operational Amplifiers - Op Amps](#) category:

Click to view products by [Maxscend](#) manufacturer:

Other Similar products are found below :

[OPA2991IDSGR](#) [OPA607IDCKT](#) [007614D](#) [633773R](#) [635798C](#) [635801A](#) [702115D](#) [709228FB](#) [741528D](#) [NCV33072ADR2G](#)
[SC2902DTBR2G](#) [SC2903DR2G](#) [SC2903VDR2G](#) [LM258AYDT](#) [LM358SNG](#) [430227FB](#) [430228DB](#) [460932C](#) [AZV831KTR-G1](#) [409256CB](#)
[430232AB](#) [LM2904DR2GH](#) [LM358YDT](#) [LT1678IS8](#) [042225DB](#) [058184EB](#) [070530X](#) [SC224DR2G](#) [SC239DR2G](#) [SC2902DG](#)
[SCYA5230DR2G](#) [714228XB](#) [714846BB](#) [873836HB](#) [MIC918YC5-TR](#) [TS912BIYDT](#) [NCS2004MUTAG](#) [NCV33202DMR2G](#)
[M38510/13101BPA](#) [NTE925](#) [SC2904DR2G](#) [SC358DR2G](#) [LM358EDR2G](#) [AZV358MTR-G1](#) [AP4310AUMTR-AG1](#) [HA1630D02MMEL-E](#)
[NJM358CG-TE2](#) [HA1630S01LPEL-E](#) [LM324AWPT](#) [HA1630Q06TELL-E](#)