



# MEA-1575-TM-TNC

GPS timing antenna  
Part #: 100-00167-01

## Description

MEA-1575-TM-TNC is a very rugged GPS timing outdoor antenna solution by Maxtena covering GPS L1/GLONASS L1, Beidou B1, Galileo E1, AND QZSS L1 frequency bands. The antenna is ideal for professional precision timing applications. This antenna allows wideband coverage and achieves superior out of band rejection with a high gain of 40dB. The MEA-1575-TM-TNC provides exceptional circular polarized signal reception exceptional multipath rejection and a wide voltage input range of 2.5 to 10 VDC. It is ideal for various outdoor GPS Timing installations.

The MEA-1575-TM-TNC is equipped with a TNC female connector and is ideal for any global GNSS time synchronization application that requires an externally mounted antenna. The antenna is designed with rugged waterproof housing (IP67 compliant) and is ideal for the most demanding environmental challenges. It can be mounted through a hole or L-Bracket.

## Electrical Specifications

Parameter	Specification
Frequency Range	1559 to 1606 MHz
Gain	5dBic @ 100mm Zenith
V.S.W.R	< 1.5:1
Radiation	Omni-Directional
Polarization	R.H.C.P.
Gain with LNA	40dBi
Impedance	50 Ω
Out-of-Band Rejection	< 1500 MHz: > 50 dB > 1650 MHz: > 50 dB

## Mechanical Specifications

Parameter	Specification
Antenna Dimensions	Φ 66.5mmx76.4 mm
Weight	0.6 kg
Operating Temperature	-45 °C to +80 °C
Antenna Radome Material	UV Resistance ABS
Connector	TNC Female
IP Rating	IP 67
Mount Type	Through hole/L-Bracket (not included) Pole mounting via clamp (included)
Pole Mount Dia.	2.0 to 2.75 in. (50 to 70mm)
Antenna Color	WHITE
ROHS Compliant	RoHS 2011/65/EU



## Features

- High bandwidth for GNSS coverage: GPS L1/GLONASS L1, Beidou B1, Galileo E1, AND QZSS L1 frequency bands
- Low VSWR
- High Gain Performance
- High out of band rejection
- Outdoor use
- Designed for harsh environment  
40dB LNA Gain
- Wide voltage input range: 2.5 to 10 VDC
- IP67 Compliant
- Filtering RF Jamming environment

## Applications

- Timing applications
- Military and security
- Utility electric grid synchronization
- Positive train control (PTC) networks
- Public safety communications
- Fixed installations

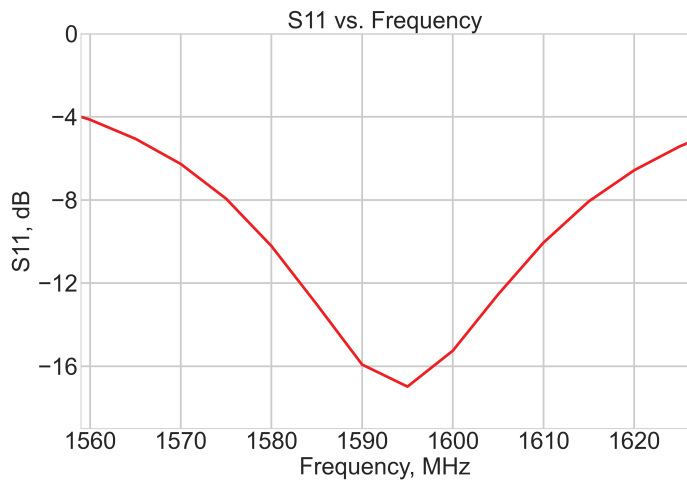

Maxtena Inc.  
7361 Calhoun Place, Suite 102  
Rockville, MD 20855  
1-877-629-8362  
info@maxtena.com  
[www.maxtena.com](http://www.maxtena.com)

D

C

B

A

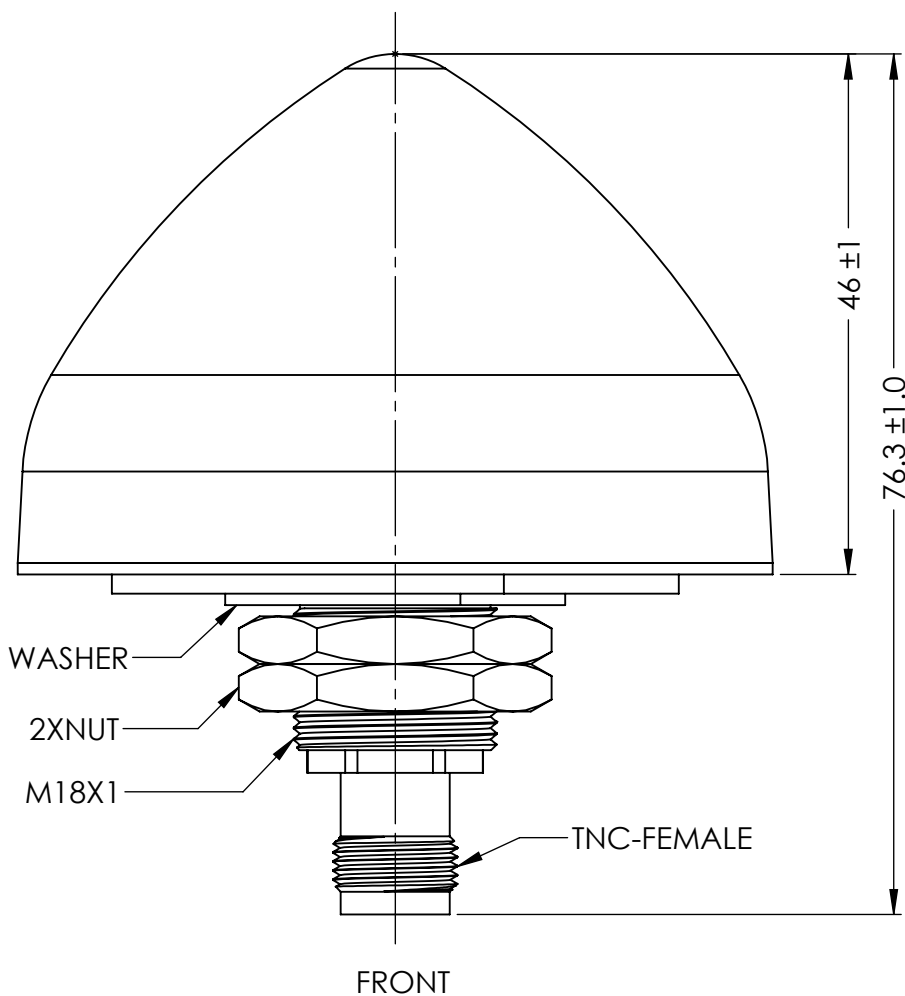

∅66.5 ±1.0

NOTES:

1. FREQUENCY: 1575.42~1602 MHz
2. POLARIZATION: RHCP
3. GAIN: 5 dBic @100MM ZENITH
4. VSWR: <1.5:1 (TYPICAL)
5. IMPEDANCE: 50 OHM
6. AXIAL RATION: 4dB @90DEGREE
7. CONNECTOR: TNC-FEMALE
8. IP RATING: IP67
9. OPERATING TEMPERATURE: -45°C ~ +80°C

ITEM 100-00167-01 REVISION HISTORY

REV	DESCRIPTION	DATE	BY
A	INITIAL RELEASE	2021-03-15	QZ

PROPRIETARY AND CONFIDENTIAL

THE INFORMATION CONTAINED IN THIS DRAWING IS THE SOLE PROPERTY OF MAXTENA, INC. ANY REPRODUCTION IN PART OR AS A WHOLE WITHOUT THE WRITTEN PERMISSION OF MAXTENA, INC IS PROHIBITED.

## X-ON Electronics

Largest Supplier of Electrical and Electronic Components

*Click to view similar products for [Antennas](#) category:*

*Click to view products by [Maxtena](#) manufacturer:*

Other Similar products are found below :

[000-16050](#) [001-0001](#) [001-0002](#) [001-0002](#) [001-0011](#) [001-0014](#) [001-0016](#) [001-0021](#) [001-0022](#) [001-0023](#) [001-0034](#) [0433AT62A0020E](#) [0600-00012](#) [0600-00019](#) [0600-00020](#) [0600-00024](#) [0600-00025](#) [0600-00028](#) [0600-00030](#) [0600-00039](#) [0600-00040](#) [0600-00048](#) [0600-00057](#) [0600-00060](#) [0830AT54A2200E](#) [0868AT43A0020E](#) [090-03390-202](#) [0900AD47A2450E](#) [0900AD54B2450E](#) [0900AT43A0070E](#) [0915AT43A0026E](#) [1000146](#) [1000418](#) [1000423](#) [1001011](#) [1001013](#) [1001039](#) [1001312](#) [1001388](#) [1001430](#) [1001932FT-AA10L0150](#) [1001932FT-AA10L0200](#) [1001932PT-AA10L0100](#) [1002089](#) [1002232](#) [1002289F0-AA10L0200](#) [1002292](#) [1002295](#) [1002298](#) [1002427](#)