



MEA-LWIG-SM

5G NR, 2.4/5.0/6.0 GHz ISM, Iridium and GNSS Screw Mount

Part #: 100-00164-01

Description

The MEA-LWIG-SM Screw Mount Antenna is a 4-in-1 low profile antenna solution, with a very high-performance ideal for maintaining constant network connectivity. The MEA-LWIG-SM covers all 5G NR, ISM, Iridium and GPS/GLONASS/QZSS/Galileo standard frequencies. This is an ideal antenna for telematics systems, remote surveillance, asset tracking and any IOT system applications. The high performance and low profile make this antenna ideal for the most challenging installations. This screw mount antenna is easy to install with maximum durability offering IP67 rated housing and anti-rotation mounting. The MEA-LWIG-SM has four cables with a SMA-Male standard connectors, 3m standard cable length and is fully customizable by offering additional connector types, cable lengths and cable types.

Cable 1:

Parameter	Specification
Frequency Range:	617-960 MHz
Return Loss:	-7.4 dB
VSWR:	3.3:1
Efficiency:	19.7 %
Peak Gain:	-1.7 dBi
Average Gain:	-8.5 dB
Frequency Range:	1427-2690 MHz
Return Loss:	-9.7 dB
VSWR:	2.3:1
Efficiency:	17.5 %
Peak Gain:	-1.7 dBi
Average Gain:	-8.6 dB
Frequency Range:	3300-5000 MHz
Return Loss:	-11.2 dB
VSWR:	2.1:1
Efficiency:	13.3 %
Peak Gain:	-1.3 dBi
Average Gain:	-9.4 dB
Frequency Range:	5150-5925 MHz
Return Loss:	-14.2 dB
VSWR:	1.7:1
Efficiency:	15.9 %
Peak Gain:	0.6 dBi
Average Gain:	-8.2 dB
Impedance	50 Ω
Polarization	Linear
Radiation Pattern	Omni-Directional
Max. Input Power	25 W

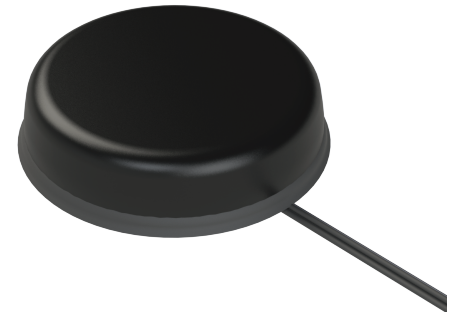

Features

- 4in1 antenna (5G NR, 2.4/5.0/6.0 GHz ISM, Iridium and GPS/GLONASS/QZSS/Galileo)
- Screw Mount
- Anti-Rotation Mechanism
- Customizable Cable and Connector
- Dimensions \varnothing 146 x 31.5 mm
- IK09, IP67, IP69K

Applications

- IoT applications
- Telematic
- Navigation
- Satellite Communications
- LTE applications

Table 2:

Parameter	Specification
Frequency Range:	2410-2490 MHz
Return Loss:	-16.7 dB
VSWR:	1.4:1
Efficiency:	30.5 %
Peak Gain:	1.2 dBi
Average Gain:	-5.2 dB
Frequency Range:	4920-5925 MHz
Return Loss:	-14.0 dB
VSWR:	1.6:1
Efficiency:	13.8 %
Peak Gain:	0.0 dBi
Average Gain:	-8.9 dB
Frequency Range:	5925-7125 MHz
Return Loss:	-7.9 dB
VSWR:	2.5:1
Efficiency:	52.1 %
Peak Gain:	5.2 dBi
Average Gain:	-3.0 dB
Impedance	50 Ω
Polarization	Linear
Radiation Pattern	Omni-Directional
Max. Input Power	10 W

Table 3:

Parameter	Specification
Frequency Range	1616 - 1627 MHz
Patch Size	36 x 36 x 4 mm
Return Loss	-18.8 dB
VSWR	1.2:1
Efficiency	76 %
Peak Gain	4.5 dBic
Average Gain	-1.1 dB
Impedance	50 Ω
Axial Ratio	≤ 3 dB
Radiation Pattern	Hemispherical
Polarization	RHCP

Table 4:

Parameter	Specification	
Frequency Range	1575.42 MHz	1598-1606 MHz
Passive Gain	3.6 dBi	
Impedance	50 Ω	
Patch Size	25 x 25 x 4 mm	
Radiation Pattern	Hemispherical	
Voltage Range	1.5 - 3.6 V	
Active Gain	28 dB @ 2.7 V	
Noise Figure	1.8 dB @ 2.7 V	
Current Consumption	9 mA @ 2.7 V	
Power Consumption	24.3 mW @ 2.7 V	
Saw Filter Type	Pre-Filter	

Mechanical Specification

Parameter	Specification
Antenna Dimensions	\varnothing 146 x 31.5 mm
Operating Temperature	-40°C to 85°C
Connector Type	SMA-Male Standard / SMA-Male-RP Standard
Mounting Type	Screw Mount
Random	ABS
Radome color	Black
Substance Compliance	RoHS
Certificates	IK09, IP67, IP69K

*Mounted on Ground Plane of 30 x 30 cm

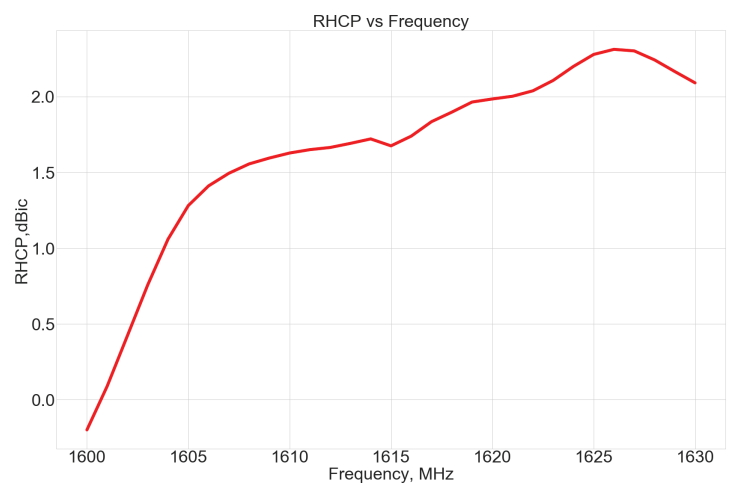
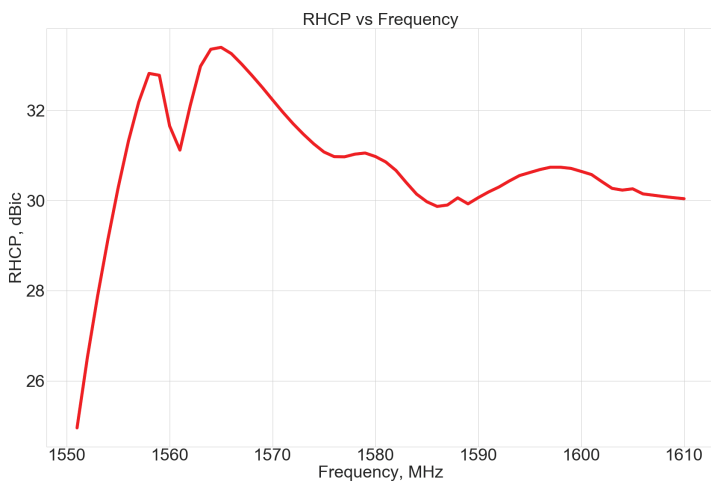

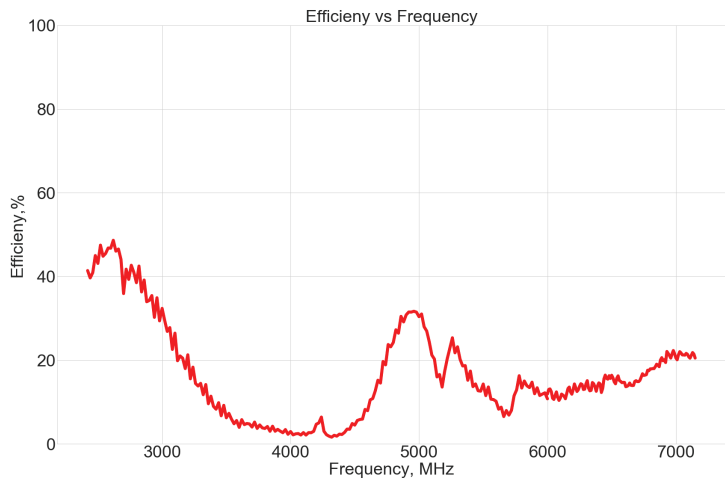
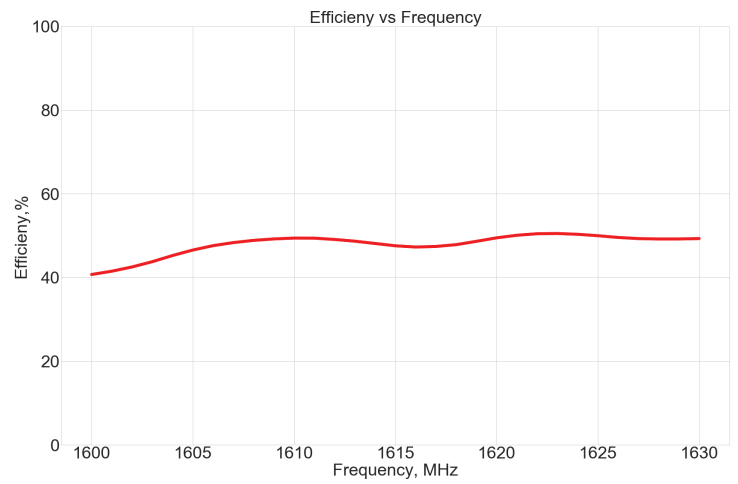
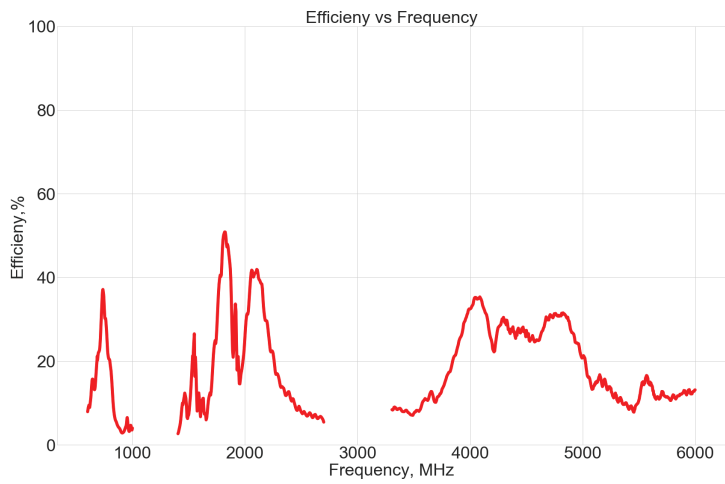
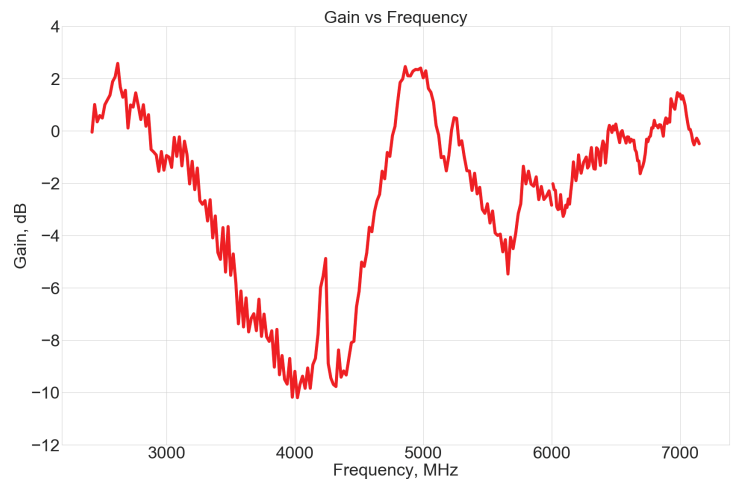
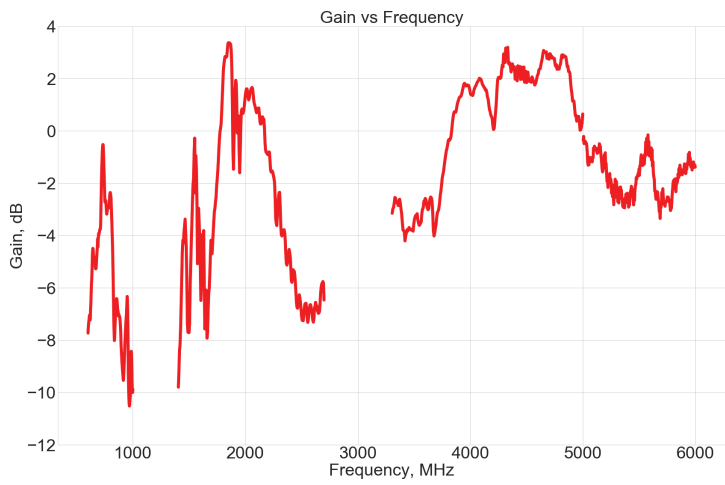

Maxtena Inc.
 7361 Calhoun Place, Suite 102
 Rockville, MD 20855
 1-877-629-8362
 info@maxtena.com
 www.maxtena.com

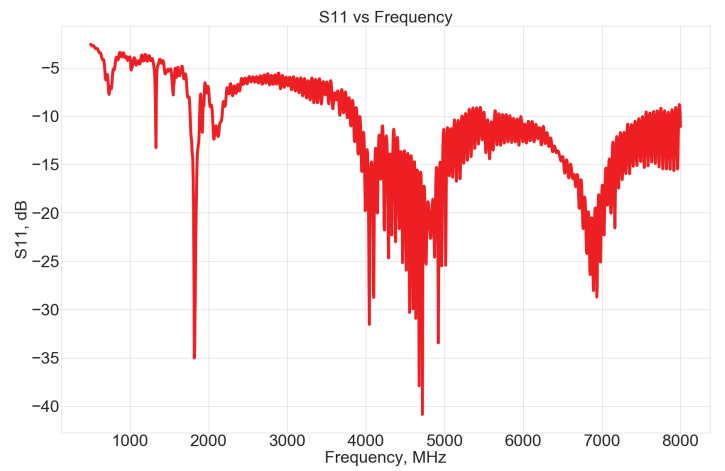
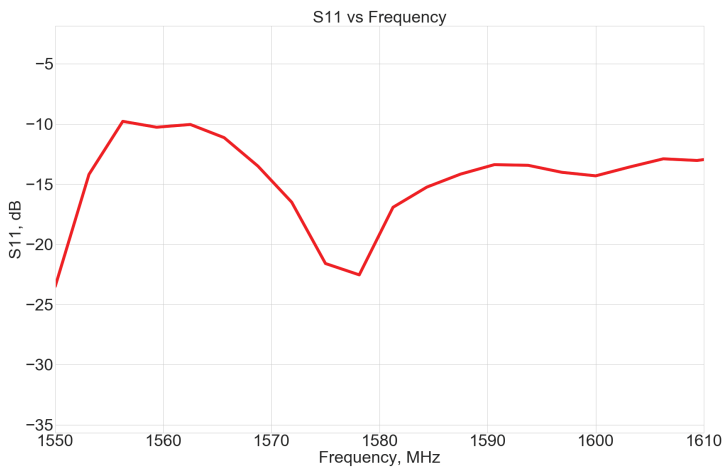
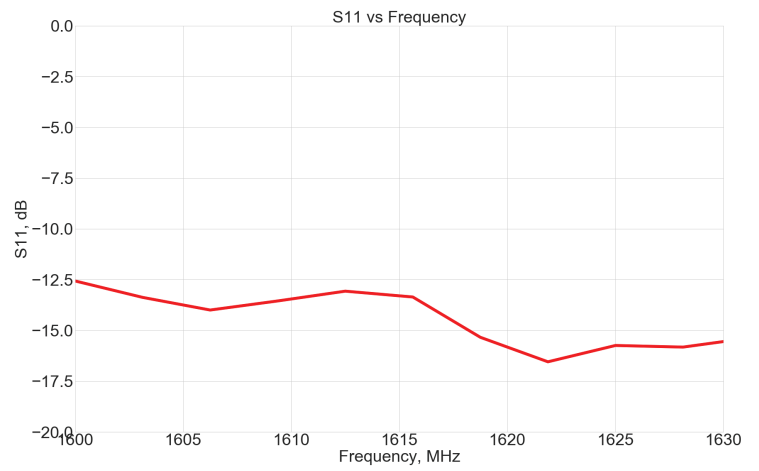
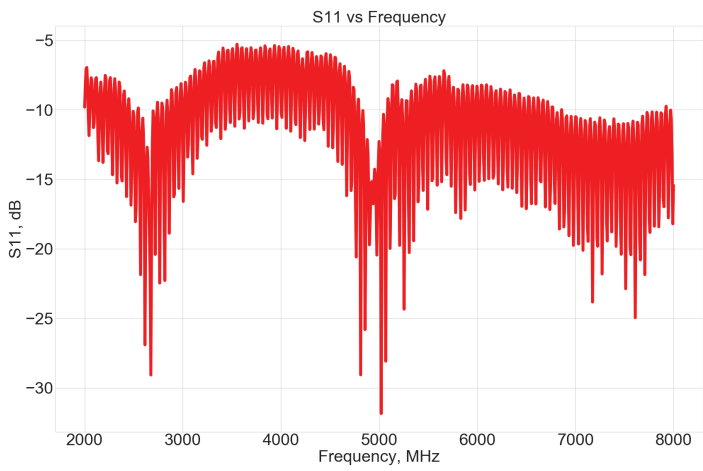

Maxtena Inc.
 7361 Calhoun Place, Suite 102
 Rockville, MD 20855
 1-877-629-8362
 info@maxtena.com
 www.maxtena.com

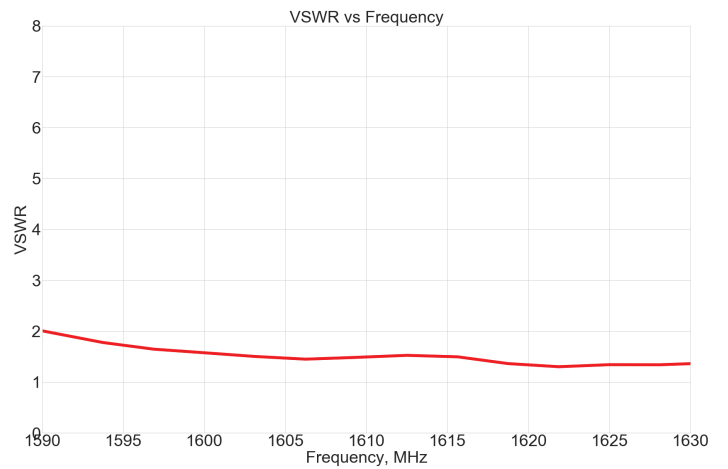
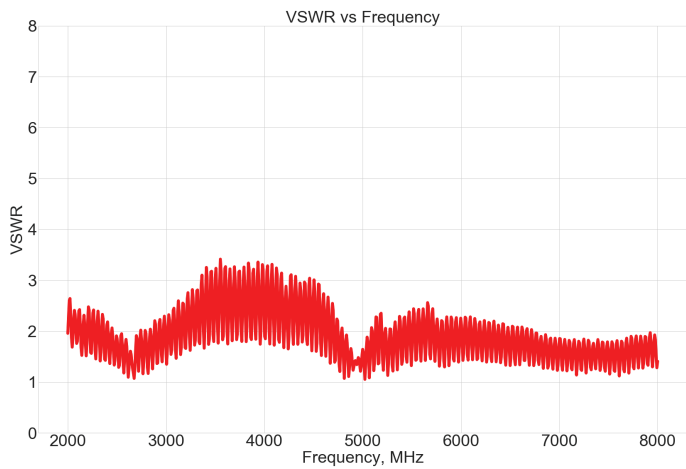
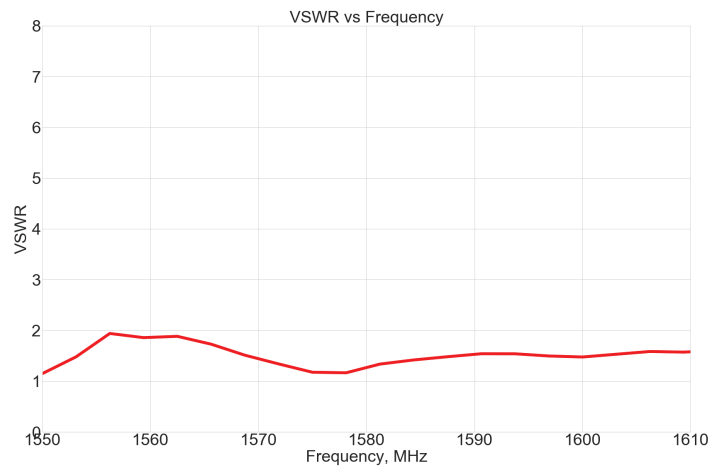
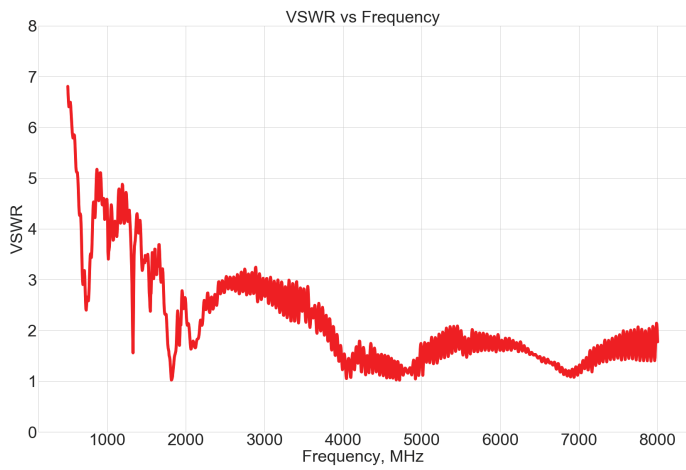

Maxtena Inc.
 7361 Calhoun Place, Suite 102
 Rockville, MD 20855
 1-877-629-8362
 info@maxtena.com
 www.maxtena.com

NOTES:

1. FREQUENCY:
 - CABLE 1 (5G NR): 617-960 MHz; 1427-2690 MHz; 3300-5000 MHz; 5150-5925 MHz
 - CABLE 2 (2.4/5.0/6.0 GHz ISM): 2410-2490 MHz; 4920-7125 MHz
 - CABLE 3 (IRIDIUM): 1616-1627 MHz
 - CABLE 4 (GPS/GLONASS/QZSS/GALILEO): 1575-1606 MHz
2. DIMENSIONS ARE AFTER MOUNTING
3. CUSTOMIZABLE CABLE AND CONNECTORS
4. MATERIALS:
 - RADOME: BLACK ABS
 - ANTENNA BASE: ZAMAK
 - GASKET: TPE
5. MECHANICAL:
 - MOUNTING TYPE: SCREW MOUNT
 - OPERATING TEMPERATURE: -40°C ~ +85°C
 - STORAGE TEMPERATURE: -40°C ~ +85°C
 - CERTIFICATES: IK09, IP67, IP69K

D

C

B

A

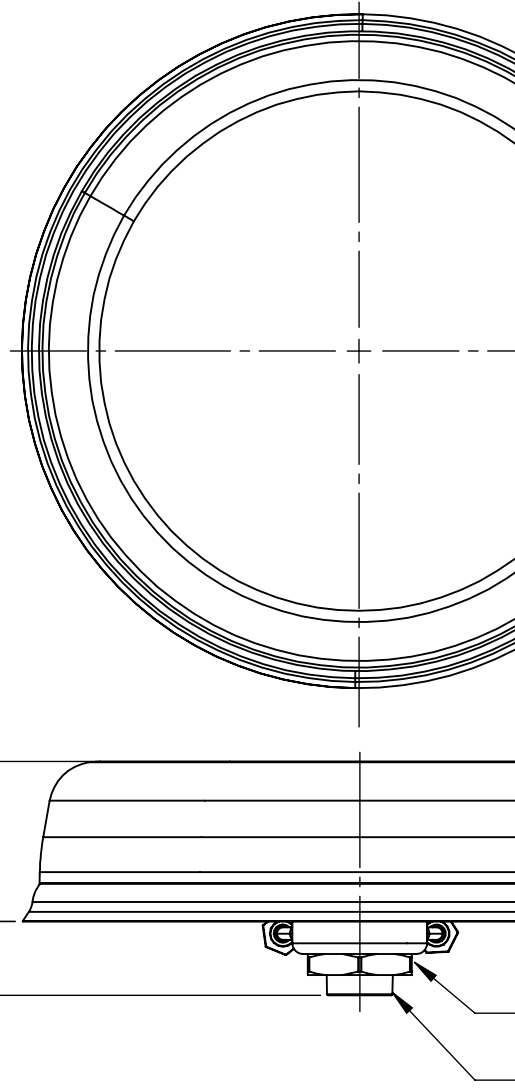

100-00164 CONFIGURATION TABLE			
DASH NO	CABLE TYPE	CABLE LENGTH	CONNECTOR TYPE
-01	CABLE 1: LMR100	200 cm	SMA-MALE GO
	CABLE 2: LMR100	200 cm	SMA-MALE GO
	CABLE 3: LMR100	200 cm	SMA-MALE GO
	CABLE 4: LMR100	200 cm	SMA-MALE GO
-02	CABLE 1: LMR100	180 cm / 6 ft	SMA-MALE GO
	CABLE 2: LMR100	180 cm / 6 ft	SMA-MALE GO
	CABLE 3: LMR100	180 cm / 6 ft	SMA-MALE GO
	CABLE 4: LMR100	180 cm / 6 ft	SMA-MALE GO

ITEM 100-00164 REVISION HISTORY			
REV	DESCRIPTION	DATE	BY
A	INITIAL RELEASE	2021-06-22	SZ

PROPRIETARY AND CONFIDENTIAL

THE INFORMATION CONTAINED IN THIS DRAWING IS THE SOLE PROPERTY OF MAXTENA, INC. ANY REPRODUCTION IN PART OR AS A WHOLE WITHOUT THE WRITTEN PERMISSION OF MAXTENA, INC IS PROHIBITED.

X-ON Electronics

Largest Supplier of Electrical and Electronic Components

Click to view similar products for [Antennas](#) category:

Click to view products by [Maxtena](#) manufacturer:

Other Similar products are found below :

[000-16050](#) [001-0001](#) [001-0002](#) [001-0002](#) [001-0011](#) [001-0014](#) [001-0016](#) [001-0021](#) [001-0022](#) [001-0023](#) [001-0034](#) [0433AT62A0020E](#) [0600-00012](#) [0600-00019](#) [0600-00020](#) [0600-00024](#) [0600-00025](#) [0600-00028](#) [0600-00030](#) [0600-00039](#) [0600-00040](#) [0600-00048](#) [0600-00057](#) [0600-00060](#) [0830AT54A2200E](#) [0868AT43A0020E](#) [090-03390-202](#) [0900AD47A2450E](#) [0900AD54B2450E](#) [0900AT43A0070E](#) [0915AT43A0026E](#) [1000146](#) [1000418](#) [1000423](#) [1001011](#) [1001013](#) [1001039](#) [1001312](#) [1001388](#) [1001430](#) [1001932FT-AA10L0150](#) [1001932FT-AA10L0200](#) [1001932PT-AA10L0100](#) [1002089](#) [1002232](#) [1002289F0-AA10L0200](#) [1002292](#) [1002295](#) [1002298](#) [1002427](#)