



MPA-258-L1-L5

GPS L1 L5 MICROSTRIP ANTENNA

Part #: 189-00057-01

Description

The MPA-258-L1-L5 is a high gain antenna customized for GPS L1 L5 frequencies. The MPA-258-L1-L5 is a multiband high-performance antenna for high precision GPS and L1 L5 accuracy and positioning. MPA-258-L1-L5 designed for embedded applications which feature GPS L1+L5 such as asset tracking and IOT solutions. The MPA-258-L1-L5 utilizes a special advanced wide-band dual-stacked ceramic patch antenna which leads to higher upper hemisphere efficiency and a lower axial ratio as compared to regular patch antennas. This allows the antenna to be superior and a top choice for demanding GPS L1+L5 multiband/multifrequency antenna requirements.



Electrical Specifications

Parameter	Specification	
Range Of Receiving Frequency	1575.42 ± 1.023 MHz	1176.45 ± 12 MHz
Center Frequency	1575 ± 3 MHz	1175 ± 3 MHz
Bandwidth	≥ 22 MHz	≥ 3 MHz
Gain at Zenith	1.8 dB i typ.	0.5 dB i typ.
Return Loss	-10 dB	
VSWR	≤ 1.8	
Polarization	RHCP	
Impedance	50 Ω	

Features

- GPS L1 L5 frequency
- Dual stacked patch
- Thru-Hole Mount
- Compact size
- Ceramic Material
- Advanced Ceramic Materials
- High Performance
- Dimensions 25 x 25 x 8 mm

Mechanical Specification

Parameter	Specification
Antenna Dimensions	25 x 25 x 8 mm
Operating Temperature	-40°C to 105°C

Applications

- IoT applications
- RTK
- Agriculture
- Navigation
- Security
- Autonomous Vehicles
- Transportation

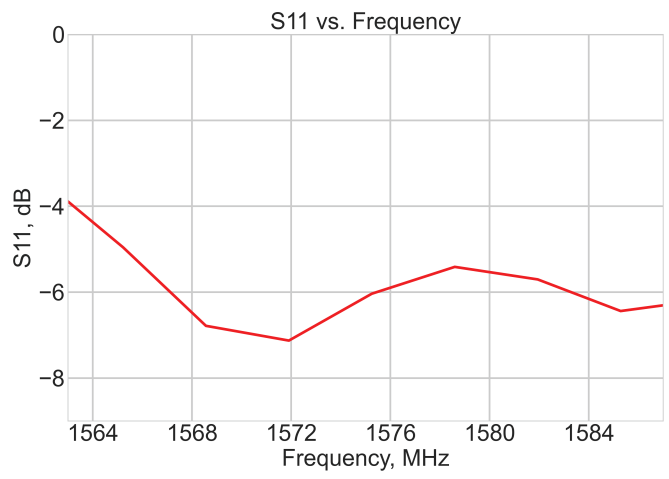
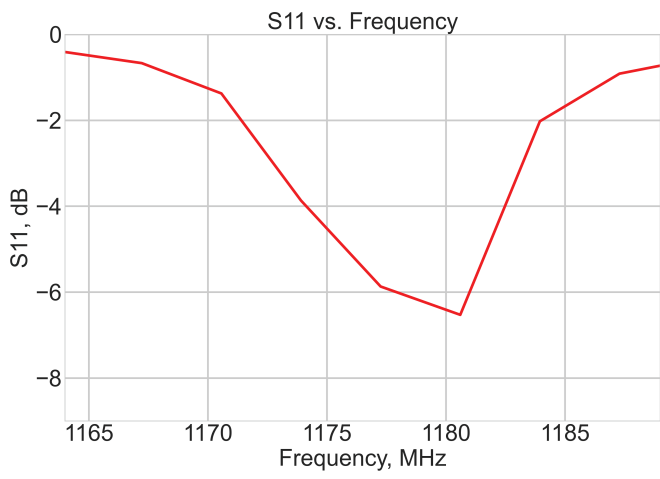

D

C

B

A

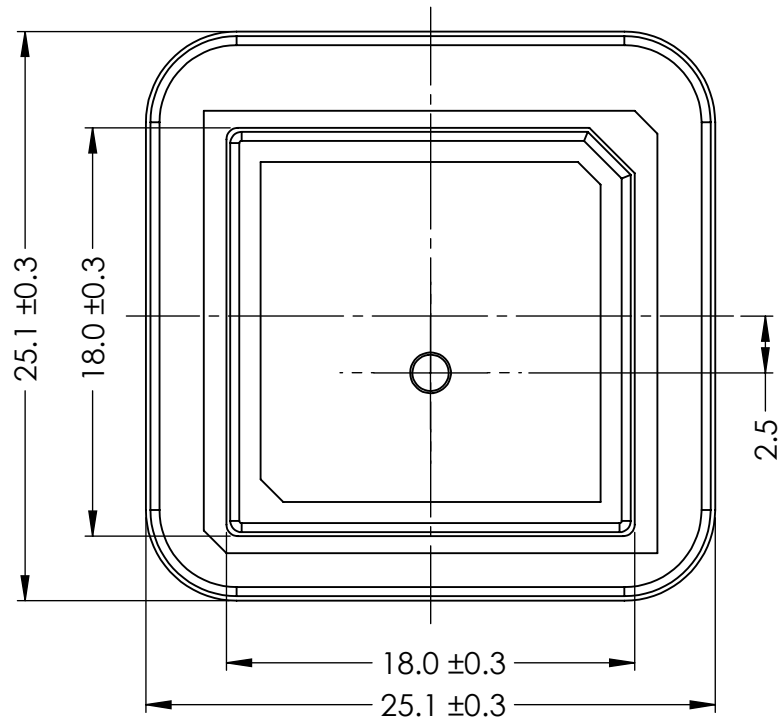

NOTES:

1. CENTER FREQUENCY:
L1: 1575MHz +- 3MHz; L2:1227MHz +- 3MHz (WITH 75X75MM GND PLANE)
2. BANDWIDTH:
L1: 20MHz MIN; L2: 8MHz MIN(RETURN LOSS@-6dB)
3. VSWR: 1.8MAX(CENTER FREQUENCY)
4. GAIN AT ZENITH:
L1: 1.8 dBi TYP. L5: 0.5dBi TYP.
5. POLARIZATION: RHCP
6. IMPEDANCE: 50OHM
7. OPERATING TEMPERATURE: -40°C TO +105°C
8. STORAGE TEMPERATURE: -40°C TO +105°C
9. DOUBLE-SIDE ADHESIVE ON THIS SURFACE FOR INDUSTRIAL USE

ITEM 189-00057-01 REVISION HISTORY

REV	DESCRIPTION	DATE	BY
A	INITIAL RELEASE	2021-03-03	QZ

PROPRIETARY AND CONFIDENTIAL

THE INFORMATION CONTAINED IN THIS DRAWING IS THE SOLE PROPERTY OF MAXTENA, INC. ANY REPRODUCTION IN PART OR AS A WHOLE WITHOUT THE WRITTEN PERMISSION OF MAXTENA, INC IS PROHIBITED.

X-ON Electronics

Largest Supplier of Electrical and Electronic Components

Click to view similar products for [Antennas](#) category:

Click to view products by [Maxtena](#) manufacturer:

Other Similar products are found below :

[GAN30084EU](#) [930-033-R](#) [GW17.07.0250E](#) [1513563-1](#) [EXE902SM](#) [APAMPG-117](#) [MAF94383](#) [W3908B0100](#) [W6102B0100](#) [YE572113-](#)
[30RSMM](#) [108-00014-50](#) [66089-2406](#) [A09-F8NF-M](#) [A09-F5NF-M](#) [RGFRA1903041A1T](#) [W3593B0100](#) [W3921B0100](#) [SIMNA-868](#) [SIMNA-](#)
[915](#) [SIMNA-433](#) [W1044](#) [W1049B090](#) [WTL2449CQ1-FRSMM](#) [CPL9C](#) [EXB148BN](#) [0600-00060](#) [TRA9020S3PBN-001](#) [GD5W-28P-NF](#)
[MA9-7N](#) [GD53-25](#) [GD5W-21P-NF](#) [EXB144SM](#) [C37](#) [MAF94051](#) [GD35-17P-NF](#) [P1744](#) [MA9-5N](#) [EXD420PL](#) [B1322NR](#) [QWFTB120](#)
[MAF94271](#) [MAF94300](#) [GPSMB301](#) [FG4403](#) [AO-AGSM-OM54](#) [5200232](#) [MIKROE-2349](#) [WCM.01.0111](#) [MIKROE-2393](#) [MIKROE-2352](#)