

FEATURES AND BENEFITS*

- Up to 500,000 duty cycles or 10 year life
- Low internal resistance
- High power performance
- 310F and 350F capacitance values
- Radial terminals for PCB mounting

TYPICAL APPLICATIONS

- Wind turbine pitch control
- Automotive subsystems
- Small UPS systems
- Consumer and industrial electronics
- Medical equipment
- Portable tools



PRODUCT SPECIFICATIONS

ELECTRICAL

	BCAP0310	BCAP0350
Rated Capacitance ¹	310 F	350 F
Minimum Capacitance, initial ¹	310 F	350 F
Maximum ESR _{DC} , initial ¹	2.2 mΩ	3.2 mΩ
Test Current for Capacitance and ESR _{DC} ¹	31 A	35 A
Rated Voltage	2.70 V	2.70 V / 2.50 V
Absolute Maximum Voltage ²	2.85 V	2.85 V
Absolute Maximum Current	250 A	170 A
Leakage Current at 25°C, maximum ³	0.45 mA	0.30 mA

TEMPERATURE

Operating temperature range (Cell case temperature)		
Minimum	-40°C	-40°C
Maximum	65°C	65°C / 70°C
Storage temperature range (Stored uncharged)		
Minimum	-40°C	-40°C
Maximum	70°C	70°C

PHYSICAL

Mass, typical	60 g	60 g
Terminals	Radial Tab	Radial Tab
Vibration	IEC 60068.2.6, SAE J2380	IEC 60068.2.6, SAE J2380
Shock	IEC 60068.2.27, SAE J2464	IEC 60068.2.27, SAE J2464

POWER & ENERGY

	BCAP0310	BCAP0350
Usable Specific Power, P _d ⁴	6,600 W/kg	4,600 W/kg
Impedance Match Specific Power ⁵	14,000 W/kg	9,500 W/kg
Specific Energy, E _{max} ⁶	5.2 Wh/kg	5.9 Wh/kg
Stored Energy ^{7,11}	0.31 Wh	0.35 Wh

*Results may vary. Additional terms and conditions, including the limited warranty, apply at the time of purchase. See the warranty details and enclosed information for applicable operating and use requirements.

PRODUCT SPECIFICATIONS (Cont'd)

SAFETY

Short Circuit Current, typical
(Current possible with short circuit from rated voltage. Do not use as an operating current.)

BCAP0310

1,200 A

BCAP0350

840 A

Certifications

UL810a, RoHS

UL810a, RoHS

TYPICAL CHARACTERISTICS

THERMAL CHARACTERISTICS

Thermal Resistance (R_{ca} , Case to Ambient), typical⁸

10.9°C/W

10.9°C/W

Thermal Capacitance (C_{th}), typical⁸

60 J/°C

60 J/°C

Maximum Continuous Current
($\Delta T = 15^\circ\text{C}$)⁸

25 A_{RMS}21 A_{RMS}

Maximum Continuous Current
($\Delta T = 40^\circ\text{C}$)⁸

41 A_{RMS}34 A_{RMS}

LIFE

DC Life at High Temperature¹
(at Rated Voltage & Maximum Operating Temperature)

1,500 hours

1,500 hours

Capacitance Change
(% decrease from minimum initial value)

20%

20%

ESR Change
(% increase from maximum initial value)

100%

100%

Projected DC Life at 25°C¹
(held continuously at Rated Voltage)

10 years

10 years

Capacitance Change
(% decrease from minimum initial value)

20%

20%

ESR Change
(% increase from maximum initial value)

100%

100%

Projected Cycle Life at 25°C^{1,9,10}

500,000 cycles

500,000 cycles

Capacitance Change
(% decrease from minimum initial value)

20%

20%

ESR Change
(% increase from maximum initial value)

100%

100%

Test Current

31 A

35 A

Shelf Life

(Stored uncharged at 25°C)

4 years

4 years

ESR AND CAPACITANCE VS TEMPERATURE

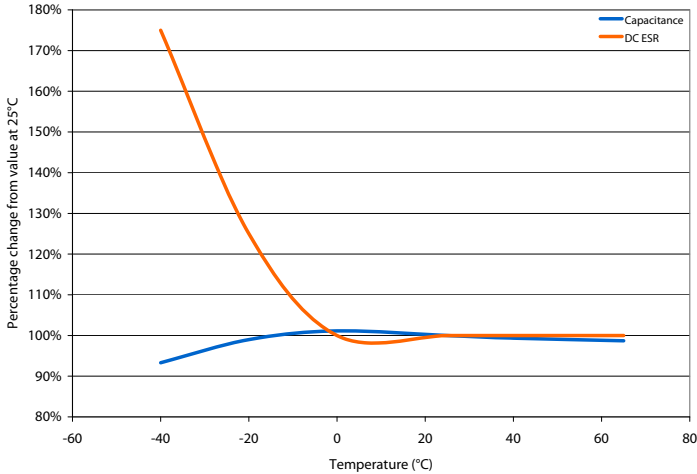

NOTES

1. Capacitance and ESR_{DC} measured at 25°C using specified test current per waveform below.
2. Absolute maximum voltage, non-repeated. Not to exceed 1 second.
3. After 72 hours at rated voltage. Initial leakage current can be higher.

4. Per IEC 62391-2, $P_d = \frac{0.12V^2}{ESR_{DC} \times \text{mass}}$

5. $P_{max} = \frac{V^2}{4 \times ESR_{DC} \times \text{mass}}$

6. $E_{max} = \frac{1/2 CV^2}{3,600 \times \text{mass}}$

7. $E_{stored} = \frac{1/2 CV^2}{3,600}$

8. $\Delta T = I_{RMS}^2 \times ESR \times R_{ca}$

9. Cycle using specified test current per waveform below.

10. Cycle life varies depending upon application-specific characteristics. Actual results will vary.
11. Per United Nations material classification UN3499, all Maxwell ultracapacitors have less than 10 Wh capacity to meet the requirements of Special Provisions 361. Both individual ultracapacitors and modules composed of those ultracapacitors shipped by Maxwell can be transported without being treated as dangerous goods (hazardous materials) under transportation regulations.

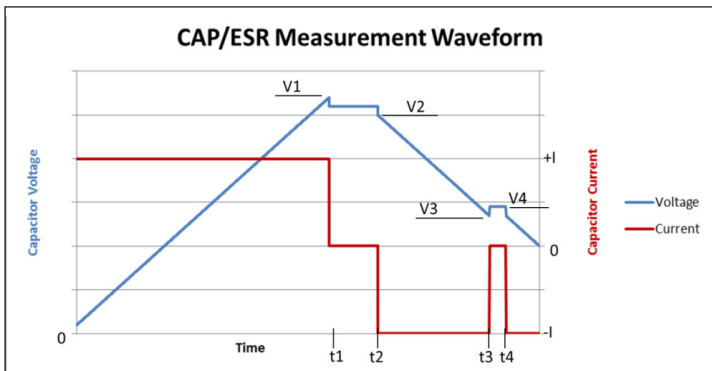

$V1 = V_{rated}$ $t2 - t1 = 15 \text{ seconds}$ $\text{Capacitance} = I \times (t3 - t2) / (V2 - V3)$
 $V3 = 0.5 \times V_{rated}$ $t4 - t3 = 5 \text{ seconds}$ $\text{ESR} = (V4 - V3) / I$

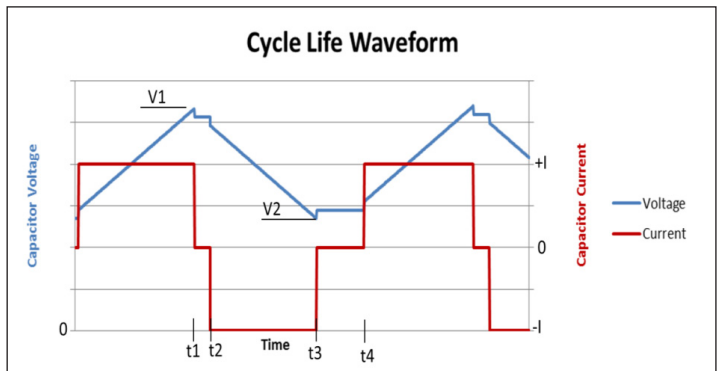

$V1 = V_{rated}$ $t2 - t1 = 5 \text{ seconds (I=0)}$
 $V2 = 0.5 \times V_{rated}$ $t4 - t3 = 15 \text{ seconds (I=0)}$

MOUNTING RECOMMENDATIONS

Do not reverse polarity. Please refer to document number 1008238, available at maxwell.com for soldering recommendations.

MARKINGS

Products are marked with the following information: Rated capacitance, rated voltage, product number, name of manufacturer, positive terminal, warning marking, serial number.

BCAP0350 E270 T11

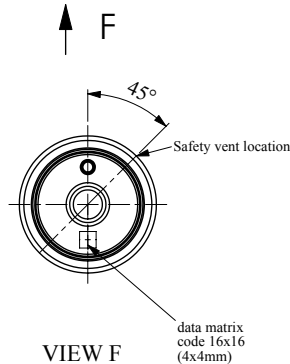
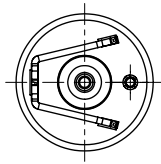
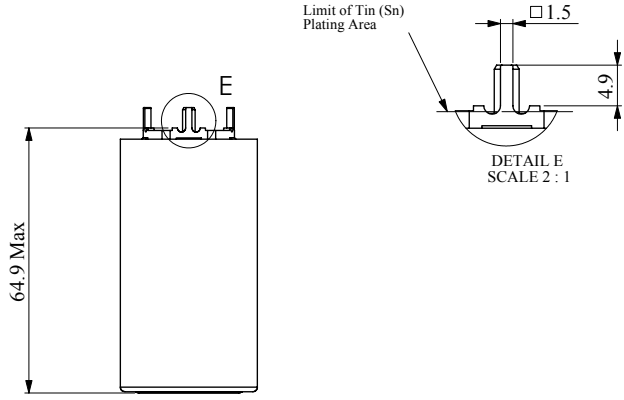
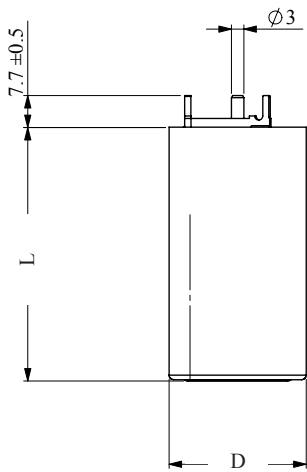

Board drillings
Board thickness : 1.5 to 3.2 mm

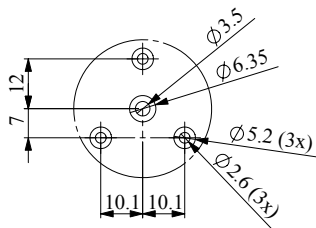

Part Description	Dimensions (mm)		Package Quantity
	L (max)	D (max)	
BCAP0350 E270 T11	61.5	33.3	250

Product dimensions are for reference only unless otherwise identified. Product dimensions and specifications may change without notice. Please contact Maxwell Technologies directly for any technical specifications critical to application.

BCAP0310 P270 T10

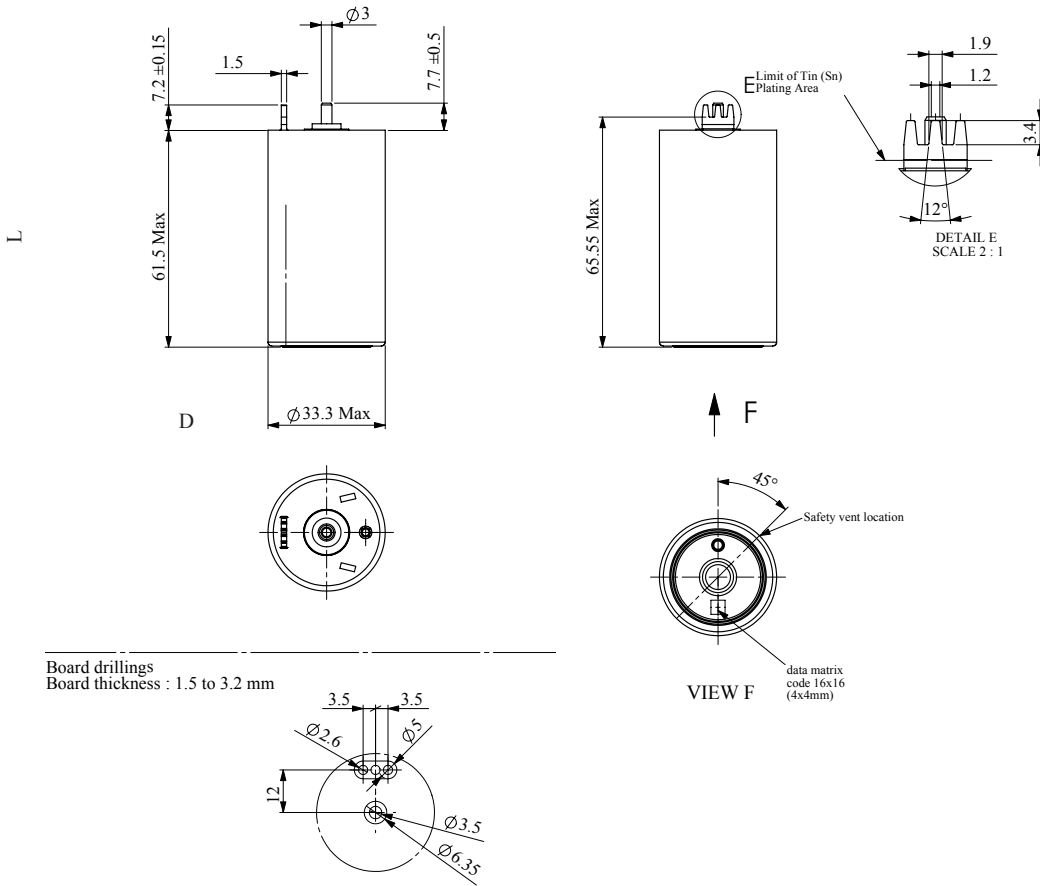

Part Description	Dimensions (mm)		Package Quantity
	L (max)	D (max)	
BCAP0310 P270 T10	61.5	33.3	250

Product dimensions are for reference only unless otherwise identified. Product dimensions and specifications may change without notice. Please contact Maxwell Technologies directly for any technical specifications critical to application. All products featured on this datasheet are covered by the following U.S. patents and their respective foreign counterparts: 6643119, 7295423, 7307830, 7342770, 7352558, 7384433, 7492571, 7508651, 7791860, 7791861, 7883553, 7935155, 8072734, 8279580, and patents pending.



Maxwell Technologies, Inc.
Global Headquarters
 3888 Calle Fortunada
 San Diego, CA 92123
 USA
 Tel: +1 858 503 3300
 Fax: +1 858 503 3301



Maxwell Technologies SA
 Route de Montena 65
 CH-1728 Rossens
 Switzerland
 Tel: +41 (0)26 411 85 00
 Fax: +41 (0)26 411 85 05



Maxwell Technologies, GmbH
 Leopoldstrasse 244
 80807 München
 Germany
 Tel: +49 (0)89 / 4161403 0
 Fax: +49 (0)89 / 4161403 99



Maxwell Technologies Shanghai Trading Co. Ltd.
 Unit A2,C 12th Floor
 Huarun Times Square
 500 Zhangyang Road,
 Pudong New Area
 Shanghai 200122,
 P.R. China
 Phone: +86 21 3852 4000
 Fax: +86 21 3852 4099



Maxwell Technologies Korea, Ltd.
 Room 1524, D-Cube City
 Office Tower, 15F #662
 Gyeongin-Ro, Guro-Gu,
 Seoul, 152-706
 South Korea
 Phone: +82 10 4518 9829

MAXWELL TECHNOLOGIES, MAXWELL, MAXWELL CERTIFIED INTEGRATOR, ENABLING ENERGY'S FUTURE, BOOSTCAP, C CELL, D CELL and their respective designs and/or logos are either trademarks or registered trademarks of Maxwell Technologies, Inc. and may not be copied, imitated or used, in whole or in part, without the prior written permission Maxwell Technologies, Inc. All contents copyright © 2013 Maxwell Technologies, Inc. All rights reserved. No portion of these materials may be reproduced in any form, or by any means, without prior written permission from Maxwell Technologies, Inc.



X-ON Electronics

Largest Supplier of Electrical and Electronic Components

Click to view similar products for [Supercapacitors](#) / [Ultracapacitors](#) category:

Click to view products by [Maxwell](#) manufacturer:

Other Similar products are found below :

[C-TEC1225 P](#) [LX055105A](#) [SCCY73B407SLBLE](#) [CDCL3000C0-002R85STB](#) [MDCM0058C0-0016R0TBZ](#) [FE0H473ZF](#) [MAL223551012E3](#)
[MAL223551014E3](#) [MAL223551015E3](#) [MAL223551016E3](#) [MAL223551006E3](#) [MAL223551007E3](#) [MAL223551001E3](#) [MAL223551008E3](#)
[MAL219612474E3](#) [MAL219632473E3](#) [DRE10/2.5](#) [DRL106S0TI25RRDAP](#) [DRL226S0TK25RR](#) [106DCN2R7M](#) [SCCT30B156SRB](#)
[SCMR14C474MSBA0](#) [SCMR22C155MSBA0](#) [FT0H225ZF](#) [GW209F](#) [TV1020-3R0605-R](#) [SCCX50B207VSB](#) [PAS0815LS2R5105](#)
[HVZ0E475NF](#) [SCMR18F105PSBA0](#) [FT0H565ZF](#) [FE0H224ZF](#) [SCCT30E156SRB](#) [MAL222090006E3](#) [SCCY68B407SSBLE](#) [CPH3225A-2K](#)
[SCMT22C505PRBA0](#) [207DCN2R7M](#) [DB5U307W35050HA](#) [DB5U407W35060HA](#) [DGH505Q5R5](#) [DGH505Q2R7](#) [DGH705Q2R7](#)
[DGH506Q2R7](#) [DGH357Q2R7](#) [DGH335Q2R7](#) [DGH256Q2R7](#) [DGH255Q5R5](#) [DGH207Q2R7](#) [DGH155Q5R5](#)