

High Current, Power Inductors

MPCA-0518-XXX-M Power Choke

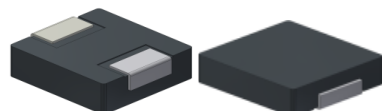

Description

- Halogen Free
- 125°C maximum total temperature operation
- 5.7 x 5.4 x 1.8mm maximum surface mount package
- Powder iron core material
- Magnetically shielded, low EMI
- High current carrying capacity, Low core losses
- Frequency range up to 5MHz
- RoHS compliant

Applications

- Voltage Regulator Module (VRM)
- Multi-phase regulators
- Point-of-load modules
- Smart phone POL modules
- SSD modules
- Notebook regulators
- Battery power systems
- Graphics cards
- Data networking and storage systems

Environmental Data

- Storage temperature range: -55°C to +125 °C
- Operating temperature range: -55°C to +125°C (ambient plus self-temperature rise)
- Solder reflow temperature: J-STD-020D compliant

Description											
MPCA-0518-1R0-M				1.0μH				±20 %			
Model				Inductance Value				Inductance Tolerance			
Global Part Number											
M	P	C	A	0	5	1	8	1	R	0	M
Product Series				Dimensions				Inductance			ValueTol.

Part No.	Inductance	DC Resistance		Heating Rating Current	Saturation Current
	L0 (μH)	DCR (mΩ)		Idc (A)	Isat (A)
	±20 %, 100 kHz, 1V	TYP.	MAX.	TYP.	TYP.
MPCA-0518-R47-M	0.47	7.7	9.0	10.5	15.5
MPCA-0518-R56-M	0.56	8.0	10.0	9.5	15.0
MPCA-0518-1R0-M	1.0	15.0	17.0	8.0	9.0
MPCA-0518-1R5-M	1.5	21.0	26.0	7.5	9.0
MPCA-0518-2R2-M	2.2	30.0	35.0	5.0	6.5
MPCA-0518-3R3-M	3.3	52.0	58.0	4.5	5.0
MPCA-0518-4R7-M	4.7	78.0	85.0	3.5	4.0
MPCA-0518-6R8-M	6.8	107.0	120.0	2.8	3.4
MPCA-0518-100-M	10.0	140.0	155.0	2.5	3.0

Notes

1. All test data is referenced to 25 °C ambient
2. Operating temperature range - 55 °C to + 125 °C
3. Idc(A):DC current (A) that will cause an approximate ΔT of 40 °C(reference ambient temperature is 25°C)
4. Isat(A):DC current (A) that will cause L0 to drop approximately 30 %
5. The part temperature (ambient + temp rise) should not exceed 125 °C under worst case operating conditions. Circuit design, component placement, PWB trace size and thickness, airflow and other cooling provisions all affect the part temperature. Part temperature should be verified in the end application.

•Dimensions-mm

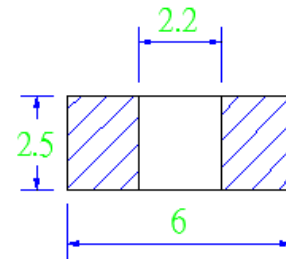
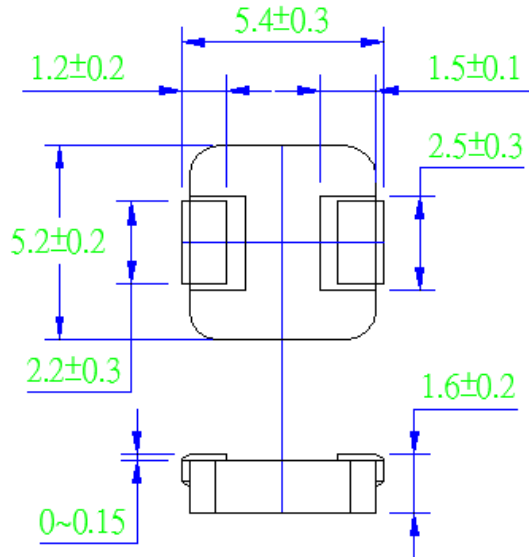

Recommend Land Pattern Dimensions

Marking

The inductor is marked with a 3-digit code

Example - -1.0→1R0

Note : Using Ink for marking



Performance Graphs																			
Test Instruments	Test Condition																		
Wayne kerr 3260B/G LCR Meter Wayne kerr 3265B Bias Current Source	Temperature: 26 ± 3°C Humidity: < 70% RH Frequency: 100 KHz, 1.0V																		
<p>MPCA-0518-R47-M</p> <table border="1"> <caption>Data for MPCA-0518-R47-M</caption> <thead> <tr> <th>DC BIAS (Amps)</th> <th>INDUCTANCE (μH)</th> <th>TEMP RISE (°C)</th> </tr> </thead> <tbody> <tr><td>0</td><td>0.47</td><td>0</td></tr> <tr><td>20</td><td>0.282</td><td>100</td></tr> </tbody> </table>	DC BIAS (Amps)	INDUCTANCE (μH)	TEMP RISE (°C)	0	0.47	0	20	0.282	100	<p>MPCA-0518-R56-M</p> <table border="1"> <caption>Data for MPCA-0518-R56-M</caption> <thead> <tr> <th>DC BIAS (Amps)</th> <th>INDUCTANCE (μH)</th> <th>TEMP RISE (°C)</th> </tr> </thead> <tbody> <tr><td>0</td><td>0.56</td><td>0</td></tr> <tr><td>20</td><td>0.336</td><td>100</td></tr> </tbody> </table>	DC BIAS (Amps)	INDUCTANCE (μH)	TEMP RISE (°C)	0	0.56	0	20	0.336	100
DC BIAS (Amps)	INDUCTANCE (μH)	TEMP RISE (°C)																	
0	0.47	0																	
20	0.282	100																	
DC BIAS (Amps)	INDUCTANCE (μH)	TEMP RISE (°C)																	
0	0.56	0																	
20	0.336	100																	
<p>MPCA-0518-1R0-M</p> <table border="1"> <caption>Data for MPCA-0518-1R0-M</caption> <thead> <tr> <th>DC BIAS (Amps)</th> <th>INDUCTANCE (μH)</th> <th>TEMP RISE (°C)</th> </tr> </thead> <tbody> <tr><td>0</td><td>1.0</td><td>0</td></tr> <tr><td>14</td><td>0.5</td><td>100</td></tr> </tbody> </table>	DC BIAS (Amps)	INDUCTANCE (μH)	TEMP RISE (°C)	0	1.0	0	14	0.5	100	<p>MPCA-0518-1R5-M</p> <table border="1"> <caption>Data for MPCA-0518-1R5-M</caption> <thead> <tr> <th>DC BIAS (Amps)</th> <th>INDUCTANCE (μH)</th> <th>TEMP RISE (°C)</th> </tr> </thead> <tbody> <tr><td>0</td><td>1.5</td><td>0</td></tr> <tr><td>14</td><td>0.6</td><td>100</td></tr> </tbody> </table>	DC BIAS (Amps)	INDUCTANCE (μH)	TEMP RISE (°C)	0	1.5	0	14	0.6	100
DC BIAS (Amps)	INDUCTANCE (μH)	TEMP RISE (°C)																	
0	1.0	0																	
14	0.5	100																	
DC BIAS (Amps)	INDUCTANCE (μH)	TEMP RISE (°C)																	
0	1.5	0																	
14	0.6	100																	
<p>MPCA-0518-2R2-M</p> <table border="1"> <caption>Data for MPCA-0518-2R2-M</caption> <thead> <tr> <th>DC BIAS (Amps)</th> <th>INDUCTANCE (μH)</th> <th>TEMP RISE (°C)</th> </tr> </thead> <tbody> <tr><td>0</td><td>2.2</td><td>0</td></tr> <tr><td>10</td><td>1.1</td><td>100</td></tr> </tbody> </table>	DC BIAS (Amps)	INDUCTANCE (μH)	TEMP RISE (°C)	0	2.2	0	10	1.1	100	<p>MPCA-0518-3R3-M</p> <table border="1"> <caption>Data for MPCA-0518-3R3-M</caption> <thead> <tr> <th>DC BIAS (Amps)</th> <th>INDUCTANCE (μH)</th> <th>TEMP RISE (°C)</th> </tr> </thead> <tbody> <tr><td>0</td><td>3.3</td><td>0</td></tr> <tr><td>8</td><td>1.65</td><td>100</td></tr> </tbody> </table>	DC BIAS (Amps)	INDUCTANCE (μH)	TEMP RISE (°C)	0	3.3	0	8	1.65	100
DC BIAS (Amps)	INDUCTANCE (μH)	TEMP RISE (°C)																	
0	2.2	0																	
10	1.1	100																	
DC BIAS (Amps)	INDUCTANCE (μH)	TEMP RISE (°C)																	
0	3.3	0																	
8	1.65	100																	

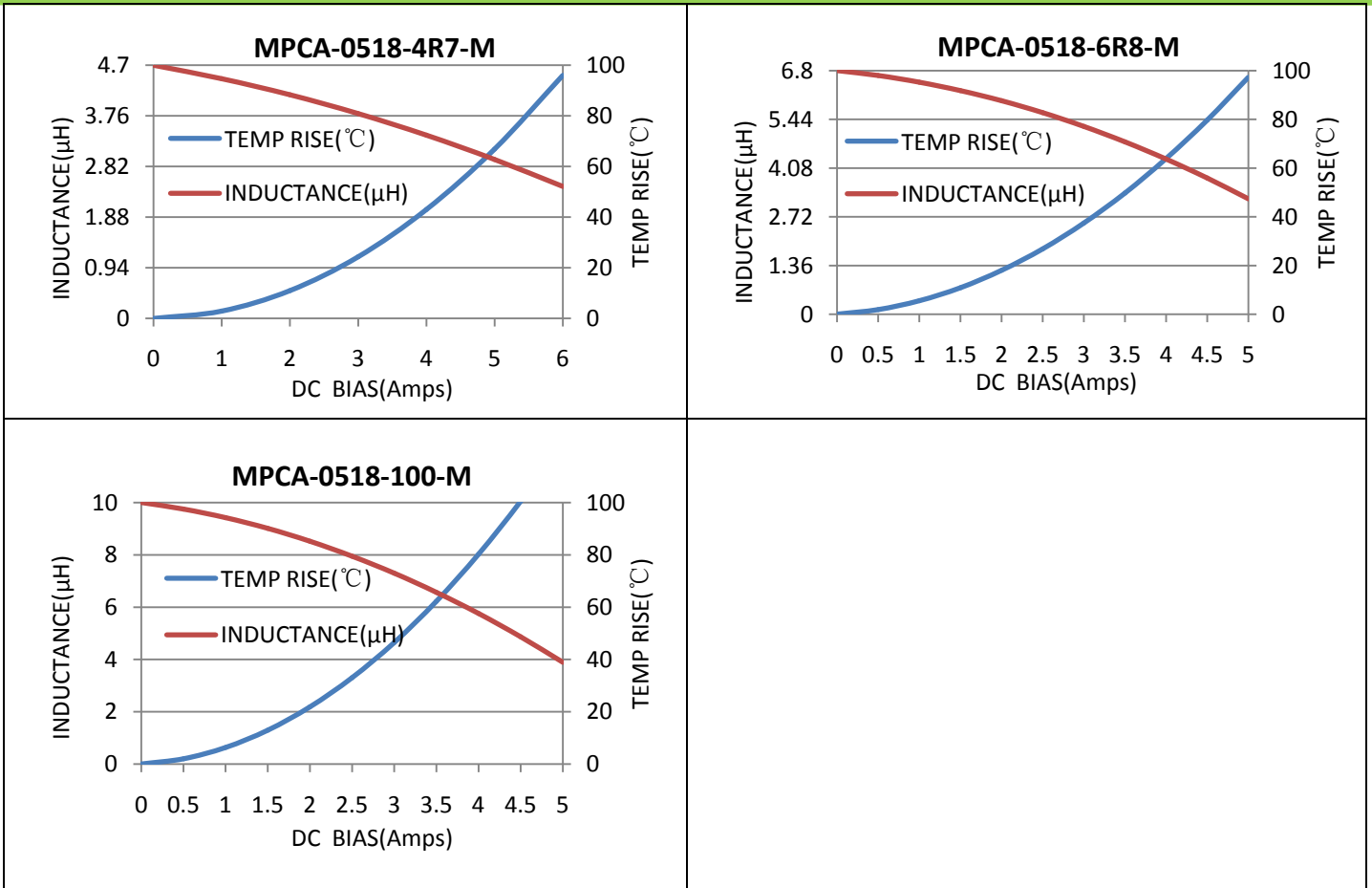

Mechanical Reliability		
Item	Specification and Requirement	Test Method
Solderability	The surface of terminal immersed shall be minimum of 95% covered with a new coating of solder	Solder heat proof: 1. Preheating: 160 ± 10 °C 2. Retention time: 245 ± 5 °C for 2 ± 0.5 seconds
Vibration	Inductance change: Within $\pm 10\%$ Without mechanical damage such as break	1. Vibration frequency: (10 Hz to 55 Hz to 10Hz) in 60 seconds as a period 2. Vibration time: Period cycled for 2 hours in each of 3 mutual perpendicular directions. 3. Amplitude: 1.5 mm max.
Shock	Inductance change: Within $\pm 10\%$ Without mechanical damage such as break	1. Peak value: 100 G 2. Duration of pulse: 11ms 3. 3 times in each positive and negative direction of 3 mutual perpendicular directions
Endurance Reliability		
Item	Specification and Requirement	Test Method
Thermal Shock	Inductance change: Within $\pm 10\%$ Without distinct damage in appearance	1. Repeat 100 cycles as follow: (-55 ± 2 °C; 30 ± 3 min) →(Room temp., 5 min) → ($+125 \pm 2$ °C, 30 ± 3 min) → (Room temp., 5 min) 2. Recovery: $48 + 4 / -0$ hours of recovery under the standard condition after the test.
High Temperature Resistance	Inductance change: Within $\pm 10\%$ Without distinct damage in appearance	1. Environment condition: 85 ± 2 °C Applied Current: Rated current 2. Duration: $1000 + 4 / -0$ hours
Humidity Resistance	Inductance change: Within $\pm 10\%$ Without distinct damage in appearance	1. Environment condition: 60 ± 2 °C Humidity: 90–95% Applied Current: Rated current 2. Duration: $1000 + 4 / -0$ hours
Low Temperature Store	Inductance change: Within $\pm 10\%$ Without distinct damage in appearance	Store temperature: -55 ± 2 °C, $1000 + 4 / -0$ hours
High Temperature Store	Inductance change: Within $\pm 10\%$ Without distinct damage in appearance	Store temperature: $+125 \pm 2$ °C, $1000 + 4 / -0$ hours

Tape Packaging Dimensions

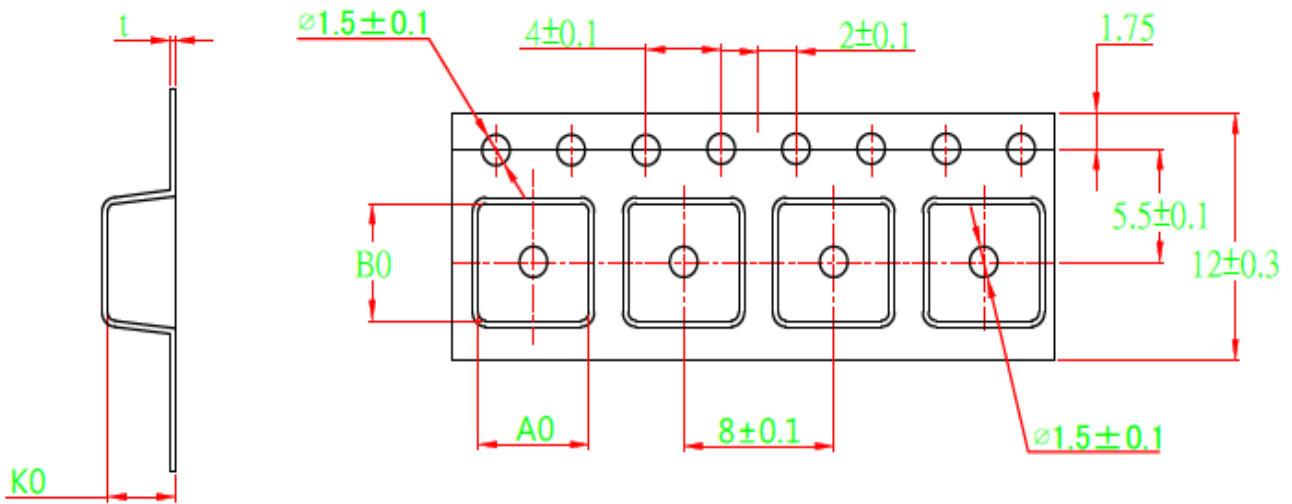

A0	B0	K0	t
5.7 ± 0.10	5.9 ± 0.10	2.3 ± 0.15	0.35 ± 0.05

Reel Dimensions

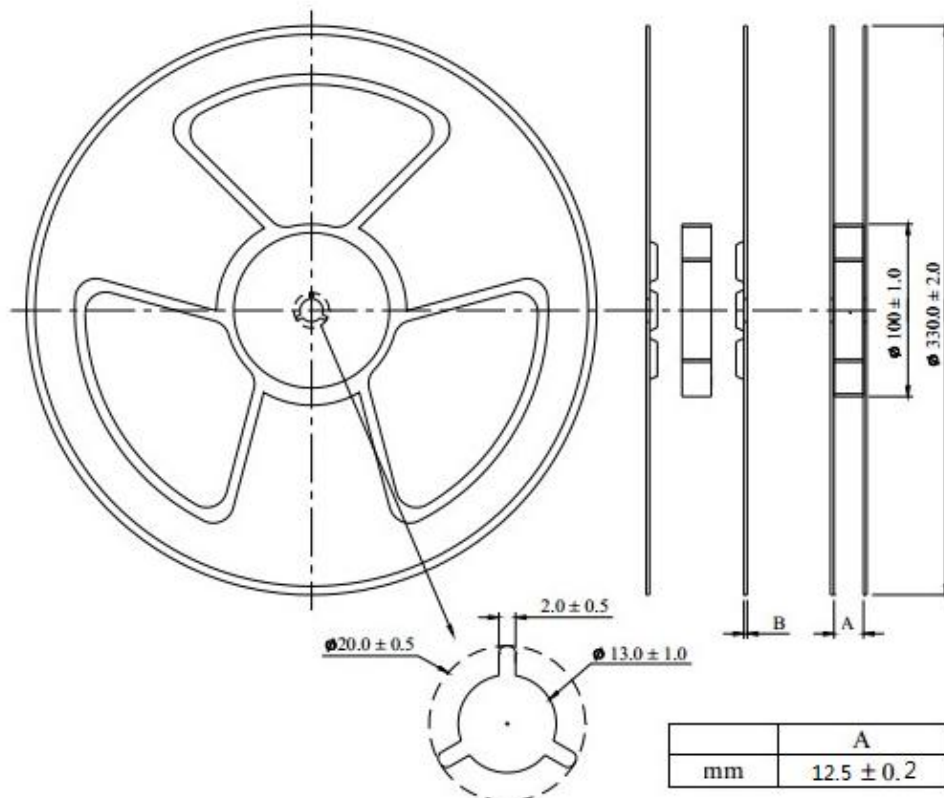

mm	A	B
	12.5 ± 0.2	2.0 ± 0.2

- Peel force of top cover tape

The peel speed shall be about 300mm/minute

The peel force of top cover tape shall be between 0.1 to 1.3N

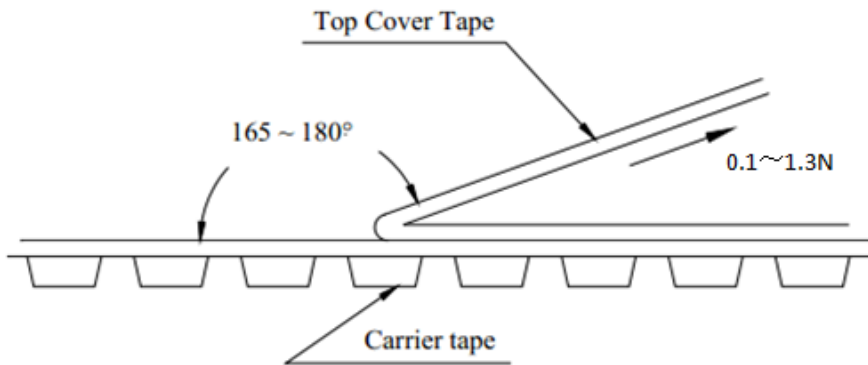

- Numbers of taping

2000pieces/reel

- Label making

The following items shall be marked on the production and shipping

Label on the reel

- Production Label

- Part No
- Description
- Quantity
- Produce No
- Taping No

- Shipping Label

- (1)*Customer's name
- (2)*Customer's part No
- (3)Manufacturer's part No
- (4)Manufacturer's name
- (5) Manufacturer's country

X-ON Electronics

Largest Supplier of Electrical and Electronic Components

Click to view similar products for [Fixed Inductors](#) category:

Click to view products by [MAZO](#) manufacturer:

Other Similar products are found below :

[CR32NP-151KC](#) [CR32NP-180KC](#) [CR32NP-181KC](#) [CR32NP-1R5MC](#) [CR32NP-390KC](#) [CR32NP-3R9MC](#) [CR32NP-680KC](#) [CR32NP-820KC](#) [CR32NP-8R2MC](#) [CR43NP-390KC](#) [CR43NP-560KC](#) [CR43NP-680KC](#) [CR54NP-181KC](#) [CR54NP-470LC](#) [CR54NP-820KC](#) [CR54NP-8R5MC](#) [70F224AI](#) [MGDQ4-00004-P](#) [MHL1ECTTP18NJ](#) [MHQ1005P10NJ](#) [MHQ1005P1N0S](#) [MHQ1005P2N4S](#) [MHQ1005P3N6S](#) [MHQ1005P5N1S](#) [MHQ1005P8N2J](#) [PE-51506NL](#) [PE-53601NL](#) [PE-53602NL](#) [PE-53630NL](#) [PE-53824SNLT](#) [PE-92100NL](#) [PG0434.801NLT](#) [PG0936.113NLT](#) [9220-20](#) [9310-16](#) [PM06-2N7](#) [PM06-39NJ](#) [A01TK](#) [1206CS-471XJ](#) [HC2LP-R47-R](#) [HC2-R47-R](#) [HC3-2R2-R](#) [HCF1305-3R3-R](#) [1206CS-151XG](#) [RCH664NP-140L](#) [RCH664NP-4R7M](#) [RCH8011NP-221L](#) [RCP1317NP-332L](#) [RCP1317NP-391L](#) [RCR1010NP-470M](#)