



■ Features

- Support 1+1 and N+1 redundancy system
- 2 channels input and 1 output
- Suitable for redundancy operation of 12V/24V/48V system
- Output current up to 40A
- Cooling by free air convection
- -40~+80°C ultra-wide operating temperature (>+60°C derating)
- Built-in 2 channels DC OK signal and alarm relay contact
- 3 years warranty

■ Applications

- Industrial control system
- Semiconductor fabrication equipment
- Factory automation
- Electro-mechanical apparatus

■ Description

The ERDN40 series is a 40A redundancy module that can be used with a power supply to improve overall system operation reliability. Product key features include: 12V/24V/48V input voltage for selection, support N+1 and 1+1 redundancy systems, built-in two rails DC input contacts and single output. The MOSFET technology implemented can reduce heat loss and reduce the voltage difference between the input and output voltages, built-in 2 channels DC OK relay contacts for monitoring output status, ultra-wide operating temperature of -40 to +80°C.

■ Model Encoding

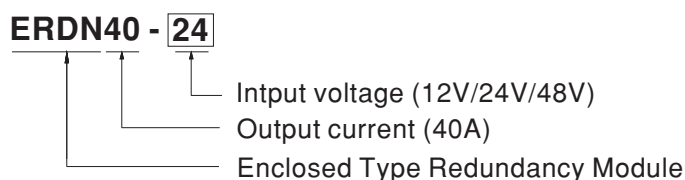

SPECIFICATION

MODEL		ERDN40-□			
		□ =12V, 24V, 48V			
INPUT	NUMBER OF INPUT	2 Channels			
	DC NORMAL VOLTAGE	12Vdc	24Vdc	48Vdc	
	DC VOLTAGE RANGE	9~14Vdc	19~29Vdc	36~60Vdc	
	RATED CURRENT	0~20A x2 input , 0~40A x1 input Continuous			
	VOLTAGE DROP (Vin-Vout) (max.)	0.2V			
	PEAK CURRENT	0~30A x2 input , 0~60A x1 input 5Sec.			
	EFFICIENCY (Typ.)	98%			
	INPUT REVERSE CURRENT (max.)	1mA			
	INPUT REVERSE VOLTAGE (max.)	40Vdc	40Vdc	65Vdc	
OUTPUT	RATED CURRENT	0~40A, Continuous			
	PEAK CURRENT (max.)	60A, 5Sec.			
	CAPACITANCE(Typ.)	320uF			
	STANDBY POWER LOSSES(Typ.)	1.5W			
PROTECTION	OVERLOAD	<60A, 5Sec. No damage			
	SHORT CIRCUIT	<60A, 5Sec. No damage			
FUNCTION	REDUNDANCY	For 1+1 redundancy ,and support N+1 redundancy			
	BOTH INPUTS VOLTAGE ALARM	<8.5V or >14.7V (±5%)	<18V or >31V (±5%)	<34.2V or >63V (±5%)	
	RELAY	30Vdc/1A resistive load			
	LED STATUS DISPLAY	Green LED OK			
ENVIRONMENT	COOLING	Free air convection			
	WORKING TEMP. <small>Note.2</small>	-40 ~ +80°C (Refer to "Derating Curve")			
	WORKING HUMIDITY	5 ~ 95% RH non-condensing			
	STORAGE TEMP.	-40 ~ +85°C			
	TEMP. COEFFICIENT	±0.03%/°C (0 ~ 60°C)			
	VIBRATION	Component:10 ~ 500Hz, 5G 10min./1cycle, 60min. each along X, Y, Z axes; Mounting: Compliance to IEC61373			
	OPERATING ALTITUDE <small>Note.3</small>	5000 meters/OVC II			
SAFETY & EMC (Note.4)	SAFETY STANDARDS	IEC62368-1, UL62368-1, EAC TP TC 004 approved			
	WITHSTAND VOLTAGE	IP/OP - Chassis : 0.5KVac ; IP/OP- Relay : 0.5KVac ; Relay - Chassis : 0.5KVac			
	ISOLATION RESISTANCE	IP/OP - Chassis, IP/OP- Relay, Relay - Chassis:>100M Ohms / 500Vdc / 25°C / 70% RH			
	EMC EMISSION	Parameter	Standard	Test Level / Note	
		Conducted	EN55032(CISPR32)	Class B	
		Radiated	EN55032(CISPR32)	Class B	
		Voltage Flicker	----	----	
	EMC IMMUNITY	Harmonic Current	----	----	
		EN55035, EN61000-6-2(EN50082-2), EN55024			
		Parameter	Standard	Test Level / Note	
		ESD	EN61000-4-2	Level 4, 15KV air ; Level 3, 8KV contact; criteria A	
		Radiated	EN61000-4-3	Level 3, 10V/m ; criteria A	
		EFT / Burst	EN61000-4-4	Level 3, 2KV ; criteria A	
Surge		EN61000-4-5	Level 3, 1KV/Line-Line ;Level 3, 2KV/Line-Line-Chassis ;criteria A		
OTHERS	MTBF	570.61K hrs min. Telcordia SR-332 (Bellcore) ; 294.12K hrs min. MIL-HDBK-217F (25°C)			
	DIMENSION	97*99*36mm (W*D*H)			
	PACKING	0.276Kg;45psc/14Kg/0.98CUFT			
NOTE	<ol style="list-style-type: none"> All parameters NOT specially mentioned are measured at normal input , rated load and 25°C of ambient temperature. Derating may be needed over high ambient temperature. Please check the derating curve for more details. The ambient temperature derating of 3.5°C/1000m with fanless models and of 5°C/1000m with fan models for operating altitude higher than 2000m(6500ft). The power supply is considered as an independent unit, but the final equipment still need to re-confirm that the whole system complies with the EMC directives. For guidance on how to perform these EMC tests, please refer to "EMI testing of component power supplies." (as available on http://www.meanwell.com) 				

■ Block Diagram

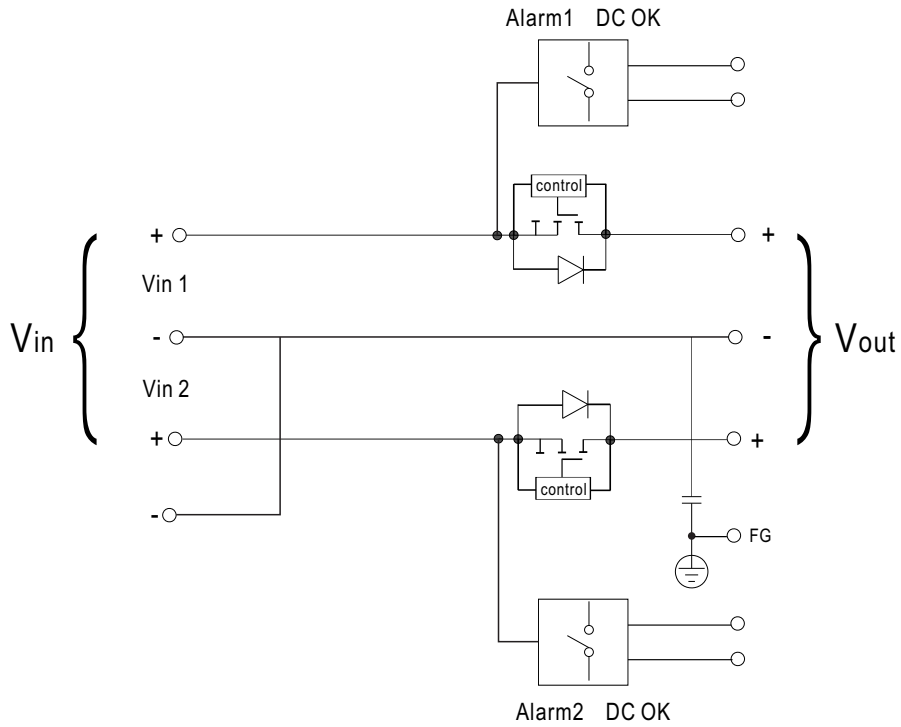

■ DC OK Relay Contact

Contact Ratings (max.)	30V/1A resistive load
Contact Close(DC OK)	PSU turns on
Contact Open(DC Fail)	PSU turns off / over or under input voltage

■ Derating Curve

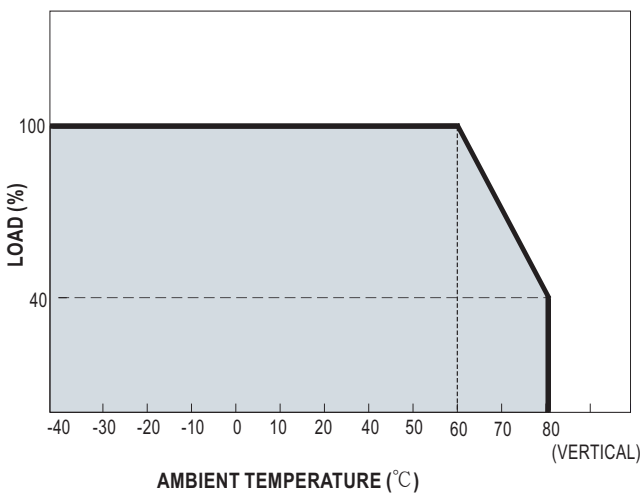

■ Output Derating VS Input Voltage

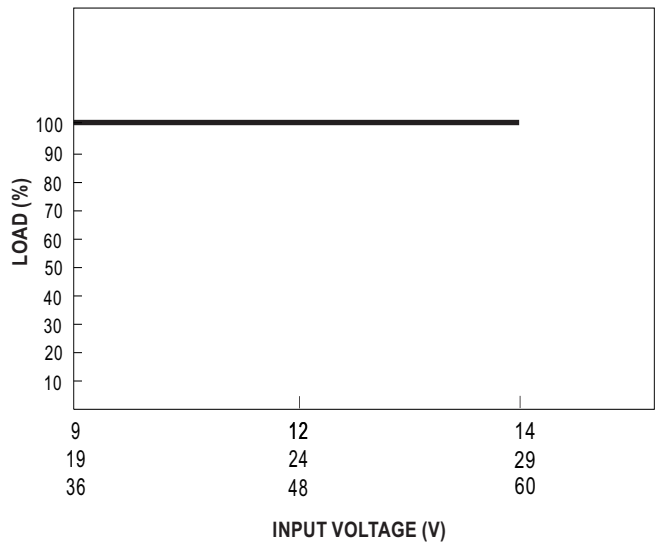

Typical Application Notes

1. 1+1 Redundancy:

Using 1 more PSU as the redundant unit

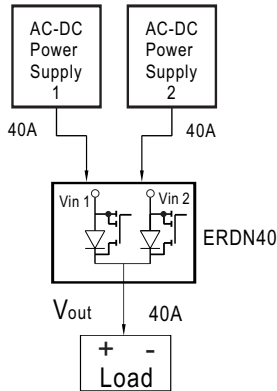

2. 1+N Redundancy:

Using more PSUs as the redundant units to increase the reliability

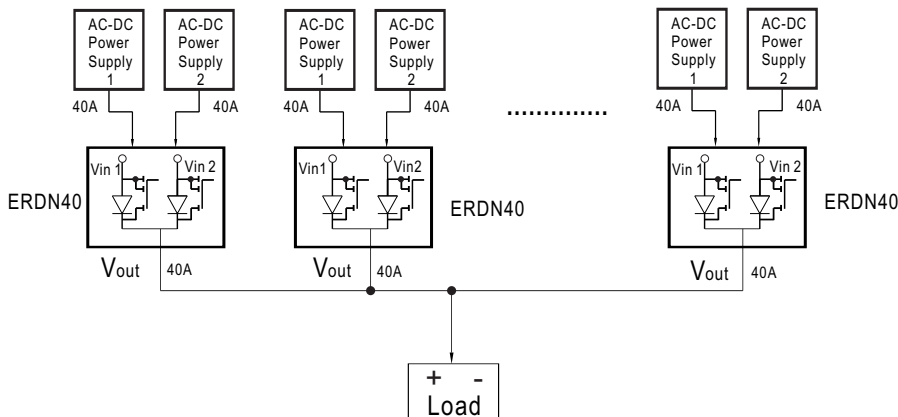

3. Single Use:

Connecting only one PSU to one ERDN40 to reduce the stress of the MOSFET and hence increase the reliability

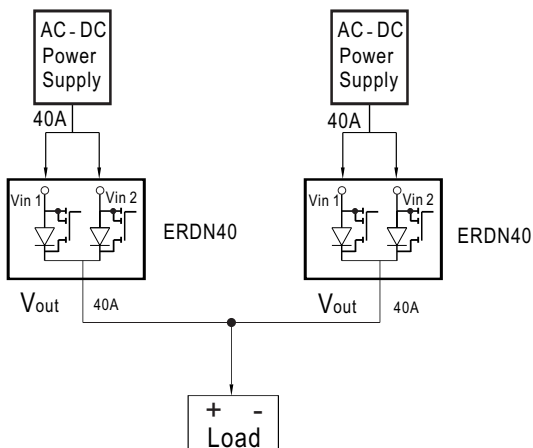

Mechanical Specification

Case No.905B Unit:mm

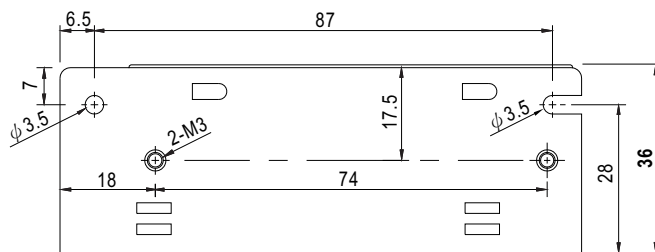
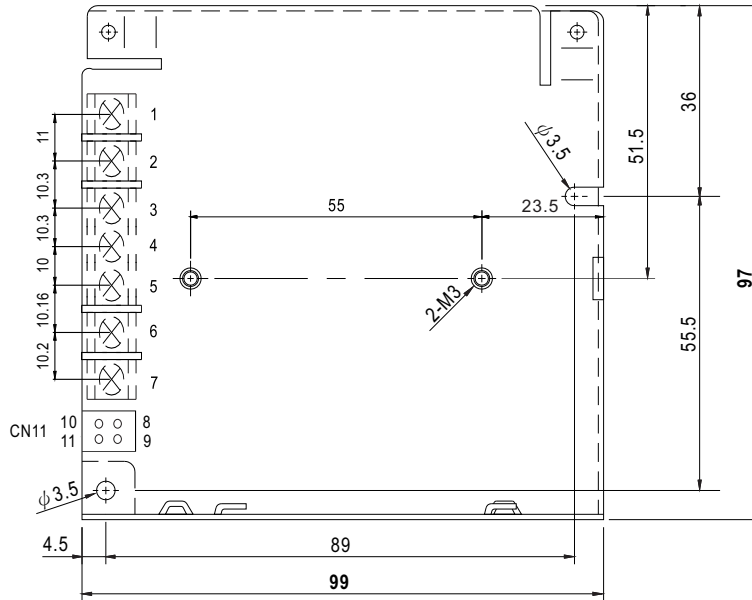

Terminal Pin No. Assignment

Pin No.	Assignment
1	FG
2	output+
3	output-
4,5	DC input -Vin
6	DC input +Vin1
7	DC input +Vin2

Function Connector(CN11): TKP DH2I-2X2 or equivalent

Pin No.	Assignment	Mating Housing	Terminal
8,9	Alarm1 DC OK	TKP DH2 or equivalent	TKP or equivalent
10,11	Alarm2 DC OK		

Installation Manual

Please refer to : <http://www.meanwell.com/manual.html>

X-ON Electronics

Largest Supplier of Electrical and Electronic Components

Click to view similar products for [Isolated DC/DC Converters](#) category:

Click to view products by [Mean Well](#) manufacturer:

Other Similar products are found below :

[PSL486-7LR](#) [Q48T30020-NBB0](#) [JAHW100Y1](#) [SPB05C-12](#) [SQ24S15033-PS0S](#) [CE-1003](#) [CE-1004](#) [MAU228](#) [J80-0041NL](#) [DFC15U48D15](#)
[XGS-1205](#) [06322](#) [SPB05B-15](#) [L-DA20](#) [DCG40-5G](#) [XKS-2405](#) [DPA423R](#) [vi-m13-cw-03](#) [VI-L53-CV](#) [24IBX15-50-0ZG](#) [HZZ01204-G](#)
[SPU02L-09](#) [SPU02M-09](#) [SPU02N-09](#) [QUINT4-BUFFER/24DC/40](#) [QUINT4-CAP/24DC/5/4KJ](#) [73-551-5039I](#) [DFC15U48D15G](#) [SEN-6471-](#)
[1EM](#) [AHV2815DF/HBB](#) [MI-LC21-IX](#) [PAH-48/8.5-D48NB1-C](#) [BM3020-7A](#) [QRS2050P025K00](#) [CM2320-9EG](#) [SKMW15F-05](#)
[V300A28H400BF3](#) [TEN 15-1223](#) [TEQ 100-2418WIR](#) [TEQ 160-7218WIR](#) [R05C05TE05S-R](#) [HQA2W085W033V-N07-S](#) [AM1SS-2405SJZ](#)
[AM2DS-1224SJZ](#) [AM2DS-2405DJZ](#) [AM10SBO-4824SNZ-B](#) [AM15E-2405S-NZ](#) [AM2DS-1212SJZ](#) [AM30SBO-4805SNZ-B](#)
[LT8301ES5#WTRPBF](#)