

- Features :
- Universal AC input / Full range
  - Protections: Short circuit / Overload / Over voltage
  - Cooling by free air convection
  - 100% full load burn-in test
  - Fixed switching frequency at 65KHz
  - 2 years warranty



## SPECIFICATION

MODEL		PT-4503		
OUTPUT	OUTPUT NUMBER	CH1	CH2	CH3
	DC VOLTAGE	3.3V	5V	12V
	RATED CURRENT	4A	4A	1A
	CURRENT RANGE	0 ~ 5A	0.2 ~ 7A	0 ~ 1.2A
	RATED POWER	Total power max. 45.2W(CH1+CH2 max. 35W)		
	RIPPLE & NOISE (max.) Note.2	50mVp-p	50mVp-p	100mVp-p
	VOLTAGE ADJ. RANGE	CH1: 3 ~ 3.6V		
	VOLTAGE TOLERANCE Note.3	±2.0%	+4,-2%	±8.0%
	LINE REGULATION	±1.0%	±1.0%	±2.0%
	LOAD REGULATION	±2.0%	±2.0%	±8.0%
SETUP, RISE TIME	800ms, 50ms at full load			
HOLD UP TIME (Typ.)	60ms at full load			
INPUT	VOLTAGE RANGE	90 ~ 264VAC 127 ~ 370VDC	[DC input operation possible by connecting AC/N(-), AC/L(+)]	
	FREQUENCY RANGE	47 ~ 63Hz		
	EFFICIENCY (Typ.)	72%		
	AC CURRENT (Typ.)	1.2A/115VAC	0.7A/230VAC	
	INRUSH CURRENT (Typ.)	COLD START 20A/115V	40A/230V	
	LEAKAGE CURRENT	<1mA / 240VAC		
PROTECTION	OVERLOAD	120 ~ 160% rated output power Protection type : Hiccup mode, recovers automatically after fault condition is removed		
	OVER VOLTAGE	5.75 ~ 6.75V on +5V Protection type : Hiccup mode, recovers automatically after fault condition is removed		
ENVIRONMENT	WORKING TEMP.	-10 ~ +60°C (Refer to "Derating Curve")		
	WORKING HUMIDITY	20 ~ 90% RH non-condensing		
	STORAGE TEMP., HUMIDITY	-20 ~ +85°C, 10 ~ 95% RH		
	TEMP. COEFFICIENT	±0.03%/°C (0 ~ 50°C)		
	VIBRATION	10 ~ 500Hz, 2G 10min./1cycle, period for 60min. each along X, Y, Z axes		
SAFETY & EMC (Note 4)	SAFETY STANDARDS	UL62368-1, TUV EN62368-1, EAC TP TC 004 approved		
	WITHSTAND VOLTAGE	I/P-O/P:3KVAC I/P-FG:2KVAC O/P-FG:0.5KVAC 1min.		
	ISOLATION RESISTANCE	I/P-O/P, I/P-FG, O/P-FG:100M Ohms / 500VDC / 25°C / 70% RH		
	EMC EMISSION	Compliance to EN55032 (CISPR32) Class B, EN61000-3-2,-3, EAC TP TC 020		
	EMC IMMUNITY	Compliance to EN61000-4-2,3,4,5,6,11, light industry level, criteria A, EAC TP TC 020		
OTHERS	MTBF	220.9Khrs min. MIL-HDBK-217F (25°C)		
	DIMENSION	127*76*28mm (L*W*H)		
	PACKING	0.23Kg; 72pcs/17.6Kg/1.28CUFT		
NOTE	<ol style="list-style-type: none"> <li>1. All parameters NOT specially mentioned are measured at 230VAC input, rated load and 25°C of ambient temperature.</li> <li>2. Ripple &amp; noise are measured at 20MHz of bandwidth by using a 12" twisted pair-wire terminated with a 0.1uf &amp; 47uf parallel capacitor.</li> <li>3. Tolerance : includes set up tolerance, line regulation and load regulation.</li> <li>4. The power supply is considered a component which will be installed into a final equipment. All the EMC tests are been executed by mounting the unit on a 360mm*360mm metal plate with 1mm of thickness. The final equipment must be re-confirmed that it still meets EMC directives. For guidance on how to perform these EMC tests, please refer to "EMI testing of component power supplies." (as available on <a href="http://www.meanwell.com">http://www.meanwell.com</a>)</li> <li>5. Mounting holes M1 and M2 should be grounded for EMI purposes.</li> <li>6. Heat Sink HS1,HS2 can not be shorted.</li> <li>7. The ambient temperature derating of 3.5°C/1000m with fanless models and of 5°C/1000m with fan models for operating altitude higher than 2000m(6500ft).</li> </ol>			

### Mechanical Specification

Unit:mm

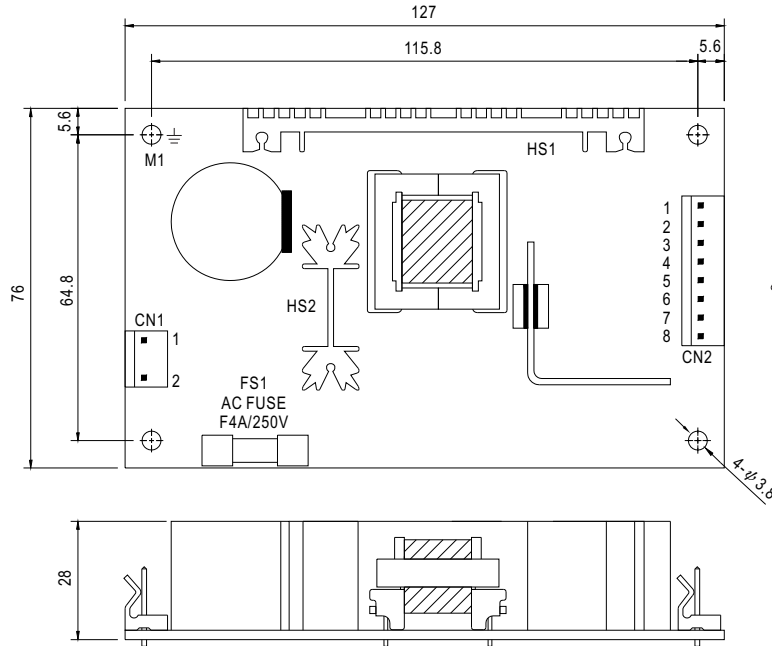

- ⚠ 1.HS1,HS2 cannot be shorted
- 2.M1 is safety ground

AC Input Connector (CN1) : Molex 5277-02 or equivalent

Pin No.	Assignment	Mating Housing	Terminal
1	AC/N(-)	Molex 5195 or equivalent	Molex 5194 or equivalent
2	AC/L(+)	Molex 5195 or equivalent	Molex 5194 or equivalent

⊥ : Grounding Required

DC Output Connector (CN2) : Molex 5273-08 or equivalent

Pin No.	Assignment	Mating Housing	Terminal
1,2	+5V	Molex 5195 or equivalent	Molex 5194 or equivalent
3,4,5	COM		
6	+V		
7,8	+3.3V		

### Block Diagram

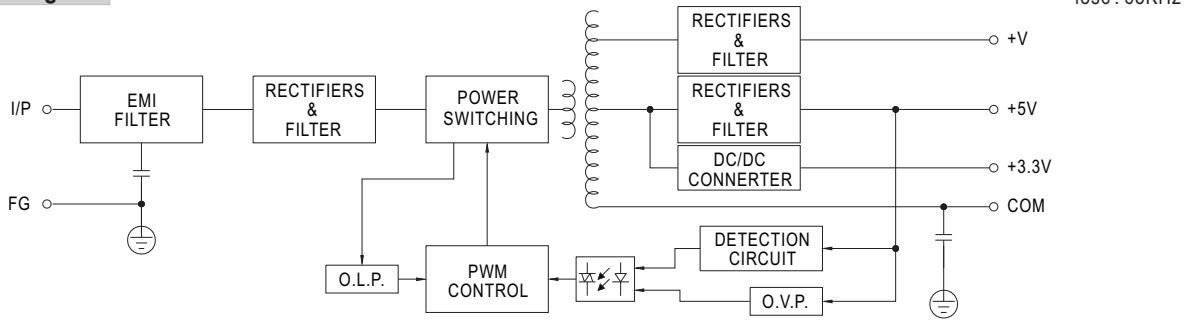

### Derating Curve

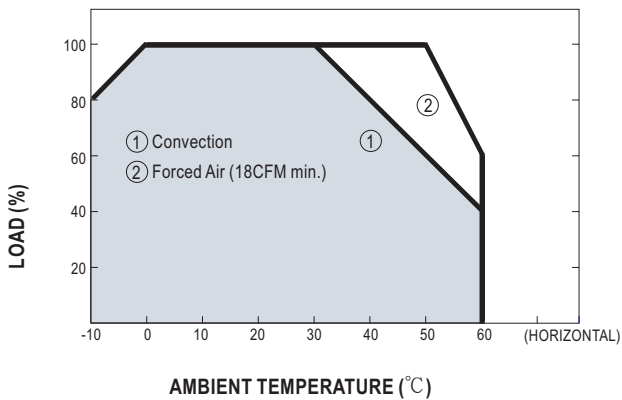

### Static Characteristics

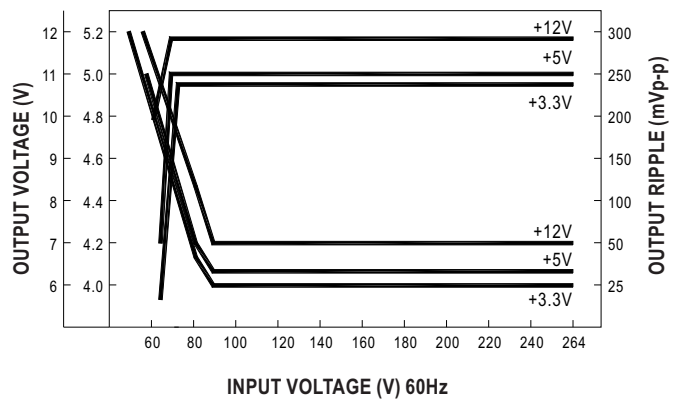

## X-ON Electronics

Largest Supplier of Electrical and Electronic Components

*Click to view similar products for [Switching Power Supplies](#) category:*

*Click to view products by [Mean Well](#) manufacturer:*

Other Similar products are found below :

[70841011](#) [73-551-0005](#) [73-551-0048](#) [PS3E-B12F](#) [PS3E-E12F](#) [AAD600S-4-OP](#) [R22095](#) [KD0204](#) [9021](#) [LDIN100150](#) [LPM000-BBAR-01](#)  
[LPX17S-C](#) [EVS57-10R6/R](#) [FP80](#) [FRV7000G](#) [22929](#) [PS3E-F12F](#) [CQM1IA121](#) [40370121900](#) [VI-PU22-EXX](#) [40370121910](#) [LDIN5075](#)  
[LPM615-CHAS](#) [LPX140-C](#) [09-160CFG](#) [70841025](#) [VPX3000-CBL-DC](#) [LPM000-BBAR-05](#) [LPM000-BBAR-08](#) [LPM124-OUTA1-48](#)  
[LPM000-BBAR-07](#) [LPM109-OUTA1-10](#) [LPM616-CHAS](#) [08-30466-1055G](#) [08-30466-2175G](#) [08-30466-2125G](#) [DMB-EWG](#) [TVQF-1219-](#)  
[18S](#) [6504-226-2101](#) [CQM1IPS01](#) [SP-300-5](#) [CQM1-IPS02](#) [VI-MUL-ES](#) [22829](#) [08-30466-0065G](#) [VI-RU031-EWWX](#) [08-30466-0028G](#) [VI-](#)  
[LUL-EU](#) [EP3000AC48INZ](#) [VP-C2104853](#)