



■ Features

- 5"×3" miniature size
- 90~264Vac input, **built-in PFC function**
- Controllable with external controller
- Fanless design for no-noise and expanding life cycle
- High surge current 200% up to 5 seconds
- Protections: Short circuit/OCP
- Provided multiple sensors for control:
Current sensor- motor torque control
DC bus voltage sensor- OVP/UVP
Temperature sensor - OTP
- -30~+70°C wide operating temperature
- Suitable for three phase motor drive (BLDC, Induction motor, SynRM)
- 3 years warranty

■ Applications

- HVAC
- Fan
- Pump
- Automatic door
- Air condition
- Conveyor
- Medical device
- Fitness equipment

■ GTIN CODE

MW Search: <https://www.meanwell.com/serviceGTIN.aspx>

■ Description

VFD-350P-230 is a variable frequency drive that can be controlled with external PWM controller. The input range is from 90VAC to 264VAC which is suitable for all kinds of installation. It is in size of 5" x 3" and built-in PFC function. VFD-350P-230 able to deliver 200% peak load and with fan-less design, the life time can be extended. VFD is suitable for three-phase motor drive, such as BLDC, Induction motor, SynRM applications.

■ Model Encoding

VFD - 350 P - 230

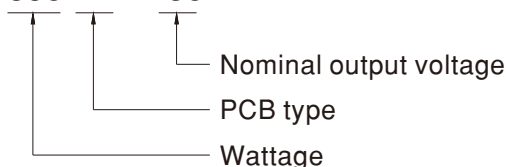

SPECIFICATION

MODEL NO.		VFD-350P-230		
OUTPUT	VOLTAGE RANGE(UVW) <small>Note.1</small>	Three phase line-to-line 0~240V, suit for 200-240V class motor		
	CAPACITY	350W		
	CURRENT	CONVECTION	1.4A	
		15CFM	2.2A	
	POWER	CONVECTION	350W	
		15CFM	550W	
	PEAK CURRENT 15CFM <small>Note.2</small>	2.8A		
	EFFICIENCY <small>Note.3</small>	93%		
DC BUS VOLTAGE		380 ± 5VDC		
INPUT	RATED INPUT VOLTAGE	90 ~ 264VAC		
	INPUT FREQUENCY RANGE (Hz)	47 ~ 63Hz		
	POWER FACTOR (Typ.)	PF>0.99/115VAC, PF>0.93/230VAC at full load		
	RATED INPUT CURRENT	3.5A /115VAC 2A/230VAC		
	INRUSH CURRENT	Cold start 70A		
	LEAKAGE CURRENT	<2mA/240VAC		
FUNCTION <small>(Note.5)</small>	INVERTER PWM INPUT	PWM control signal input for driving inverter IGBTs. (PIN8~13 of CN93) TTL input : IGBT ON: High(>2.6V); IGBT OFF: Low(<0.8V) ; lin =2mA		
	FAULT SIGNAL	Inverter fault signal(Short circuit/OCP, PIN7 of CN93). TTL input: Normal: High(>3V); Abnormal: Low(<0.5V)		
	DC BUS VOLTAGE SENSOR	DC BUS voltage sensor output(HV+ sensor, PIN1 of CN93): 2.5V@DC BUS 380V		
	THREE PHASE CURRENT SENSOR	Built-in 100mΩ low-side shunt resistor (each phase), (PIN4~6 of CN93)		
	THERMAL SENSOR	Built-in 10KΩ NTC for sensing IGBTs operating temperature. (TSM2A103F34D1R (Thinking Electronic), PIN2 of CN93)		
	AUXILIARY POWER VCC	Non-isolated 15V output power for user's application. Max current : 0.1A, Ripple:1V		
PROTECTION	SHORT CIRCUIT	Protection type : Shut down o/p voltage, re-power on to recover		
OUTPUT FREQUENCY	SWITCHING FREQUENCY RANGE	2.5KHz ~ 15KHz		
ENVIRONMENT	COOLING SYSTEM	Air convection		
	WORKING TEMP.	-30 ~ +70°C (Refer to "Dreating Curve")		
	WORKING HUMIDITY	20 ~ 90% RH non-condensing		
	STORAGE TEMP., HUMIDITY	-40 ~ +85°C, 10 ~ 95% RH non-condensing		
	VIBRATION	10 ~ 500Hz, 2G 10min./1cycle, period for 60min. each along X, Y, Z axes		
SAFETY & EMC	SAFETY STANDARDS	CB IEC61800-5-1, TUV BS EN/EN61800-5-1, EAC TP TC004 approved		
	WITHSTAND VOLTAGE	I/P-FG:2KVAC		
	ISOLATION RESISTANCE	I/P-FG:100M Ohms/500VDC/25°C / 70%RH		
	EMC EMISSION	Parameter	Standard	Test Level / Note
		Conducted	BS EN/EN IEC61800-3	Class A, C2
		Radiated	BS EN/EN IEC61800-3	Class A, C2
		Harmonic Current	BS EN/EN IEC61000-3-2	Class A
		Voltage Flicker	BS EN/EN61000-3-3	-----
	EMC IMMUNITY	BS EN/EN IEC61800-3, second environment		
		Parameter	Standard	Test Level / Note
		ESD	BS EN/EN61000-4-2	Level 3, 8KV air ; Level 2, 4KV contact
		Radiated	BS EN/EN IEC61000-4-3	Level 3
		EFT/Burest	BS EN/EN61000-4-4	Level 3
		Surge	BS EN/EN61000-4-5	Level 3, 2KV/Line-Earth ; Level 3, 1KV/Line-Line
		Conducted	BS EN/EN61000-4-6	Level 3
		Magnetic Field	BS EN/EN61000-4-8	Level 4
Voltage Dips and Interruptions		BS EN/EN IEC61000-4-11	>95% dip 0.5 periods, 30% dip 25 periods, >95% interruptions 250 periods	
Voltage deviation		IEC 61000-2-4 Class 2	±10% Un	
Total Harmonic distortion (THD) Individual Harmonic orders		IEC 61000-2-4 Class 3 IEC 61000-4-13 Class 3	THD 12 %	
Frequency variations	IEC 61000-2-4	±4%		
Frequency rate of change	IEC 61000-2-4	2%/s		
OTHERS	MTBF	2530.7K hrs min.Telcordia SR-332 (Bellcore) ; 199.7K hrs min.MIL-HDBK-217F (25°C)		
	DIMENSION (L*W*H)	127*76.2*35mm		
	PACKING	0.27Kg;48pcs/13.7kg/2.01CUFT		
NOTE	<ol style="list-style-type: none"> 3-phase 220V motor is recommended.Please consider the rated current when used for 100-120V class motor. Refer to peak load usage definition. Efficiency is tested by 250W with 150VAC output line-to-line voltage. All parameters NOT specially mentioned are measured at 230VAC input, rated load and 25°C of ambient temperature. Please refer to page 4 for more details. <p>※ Product Liability Disclaimer : For detailed information, please refer to https://www.meanwell.com/serviceDisclaimer.aspx</p>			

Block Diagram

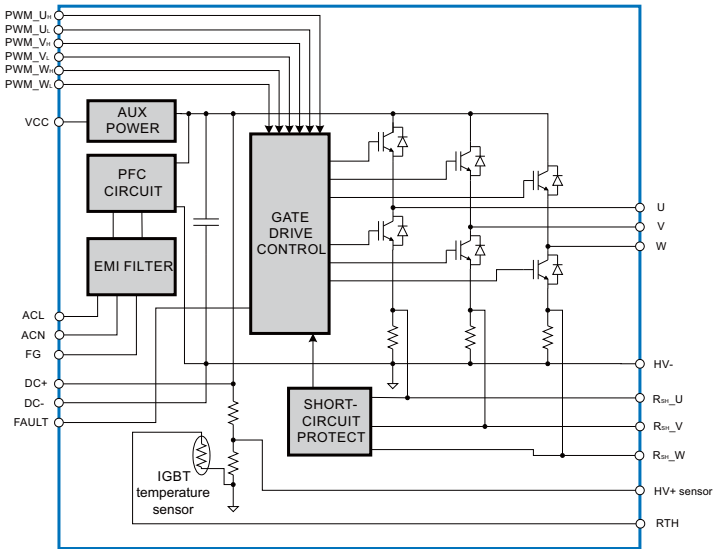

V/I CURVE

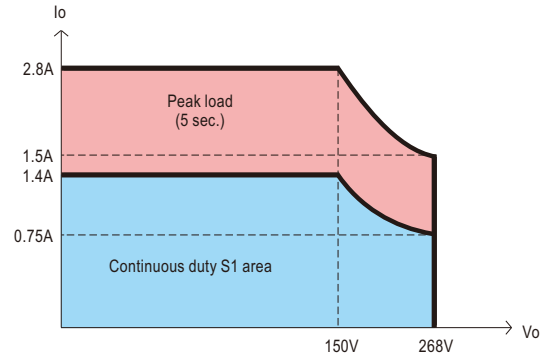

Derating Curve

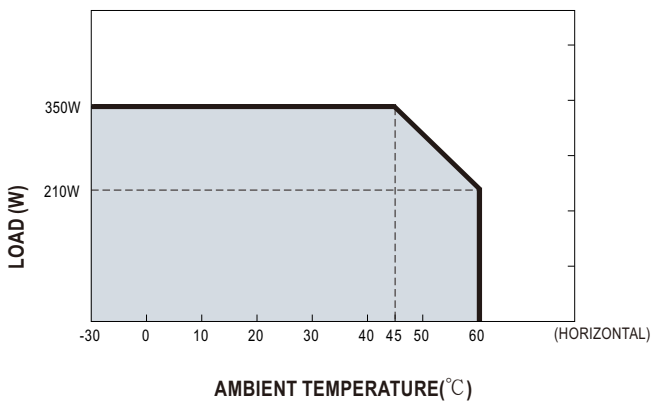

Output Derating VS Input Voltage

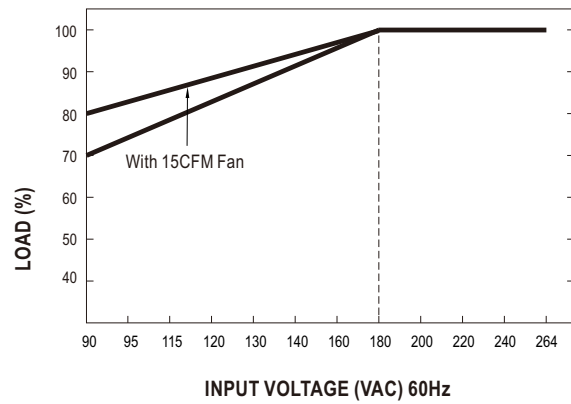

Peak Load

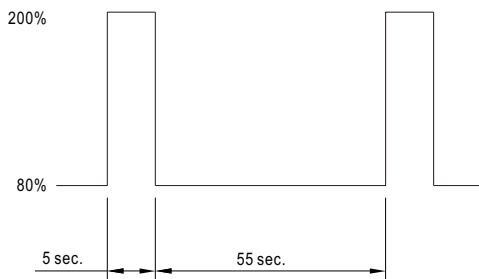

Efficiency vs Load

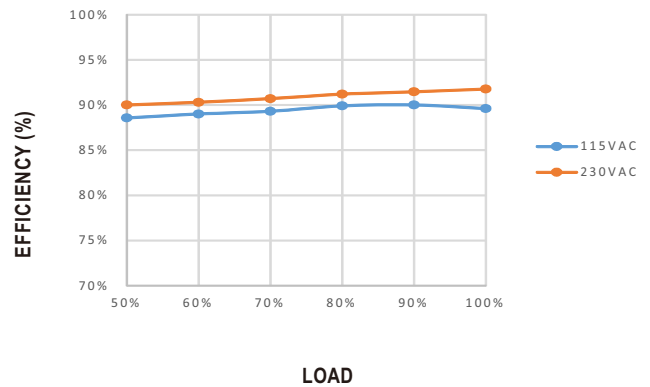

Function Manual

1. 3-phase PWM Control

VFD-350P-230 provides six-switch circuit by using 3 half-bridge IGBTs. IGBTs of each phase is controlled by PWM_U_H/U_L, PWM_V_H/V_L and PWM_W_H/W_L (PIN 8~13). The input requirement for PWM is compatible with both TTL and CMOS 3.3V signals. Please refer to the diagram below.

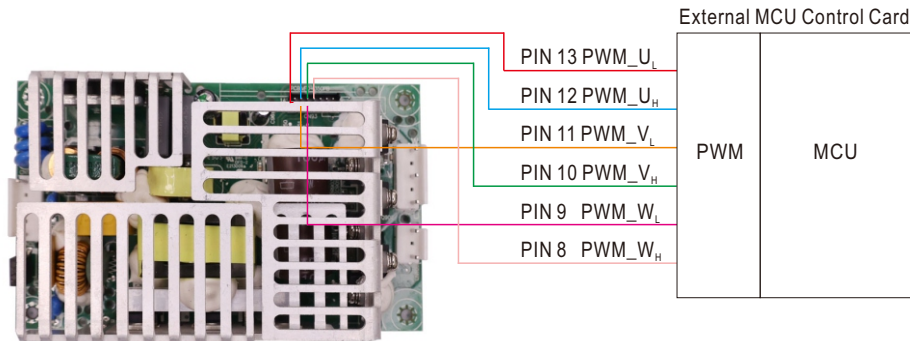

WARNING: It is necessary to keep minimum dead-time between the upper and lower switch of each phase.

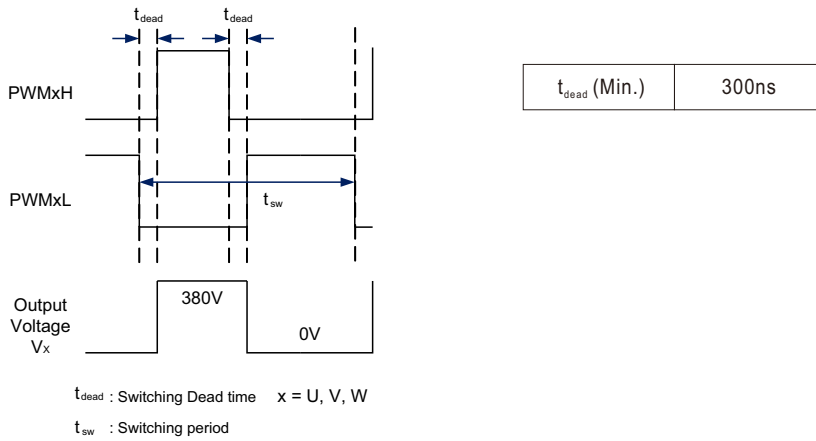

2. 3-phase Current Detection & Overcurrent Protection

Low-side shunt resistors are installed on each phase of VFD-350P-230 for current measurement and short-circuit detection. It's suggested to shorten the length of external detection circuit and detect the signal with a OPAs. Please refer to diagram below.

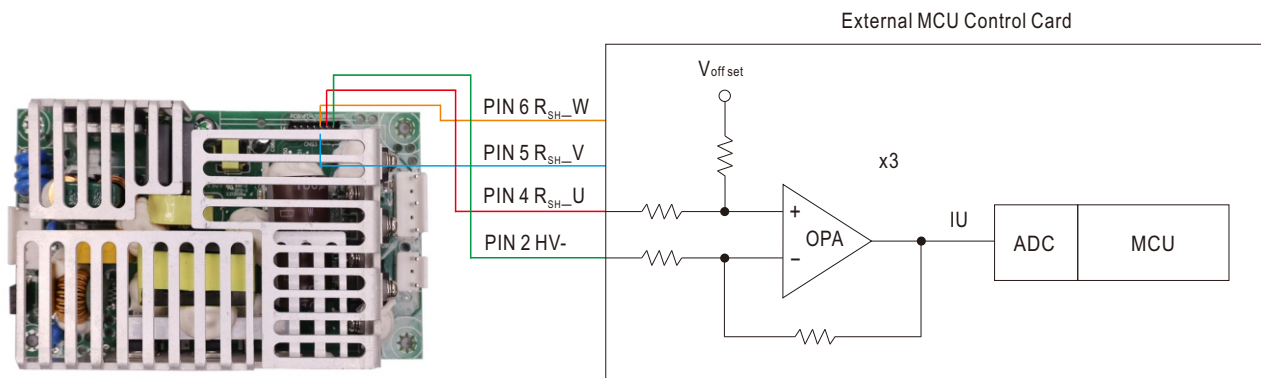

If output current exceed 200% of rated value, the protection circuit will be triggered and shut down the gate driver for protection.

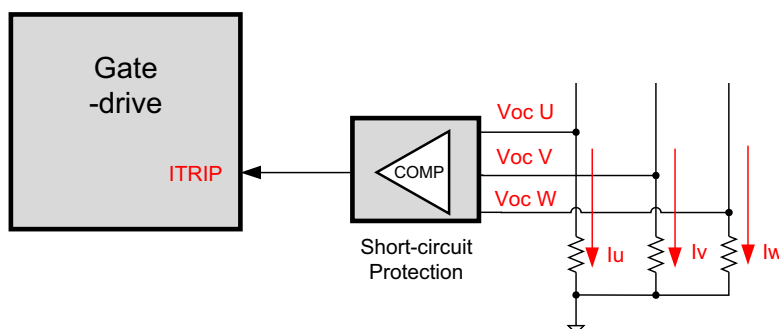

3. DC BUS Voltage Detection

VFD-350P-230 is built-in with DC bus voltage sensor(HV+ sensor, PIN 1). The sensor provides a 2.5V output when DC bus voltage is at 380V. It's suggested to detect the signal by OPAs. When the voltage of the DC bus exceed 420V, the PWM input signal must shut down for protection.

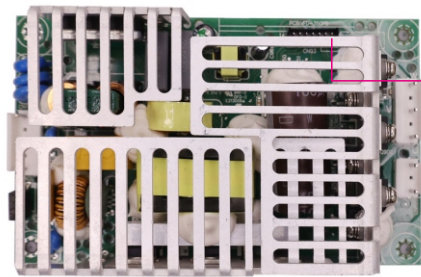

PIN1 HV+ sensor

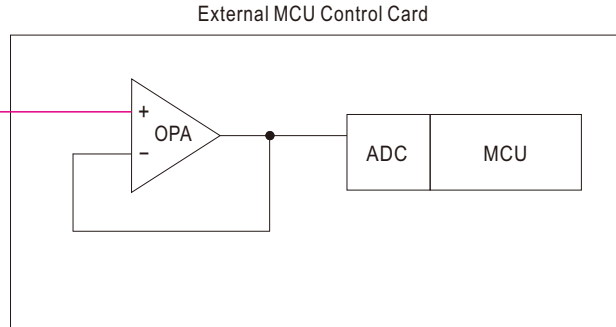

Equation for DC bus voltage calculation:

$$V_{DC\ BUS} = \frac{380 \times HV+sensor}{2.5}$$

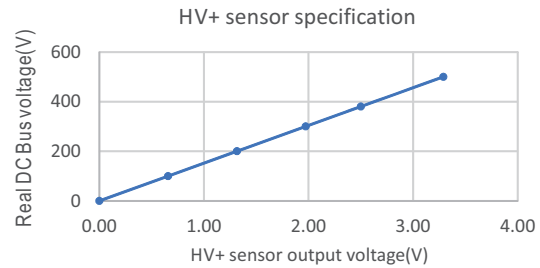

4. IGBT Temperature Detection

VFD-350P-230 is built-in a NTC resistor for detecting IGBTs temperature. Users can detect IGBTs temperature for protection. (NTC type: TSM2A103F34D1R, Thinking Electronic) The recommended detection circuit is below. It's suggested to shutdown the PWMs input, if the temperature is above 100°C. (no fan).

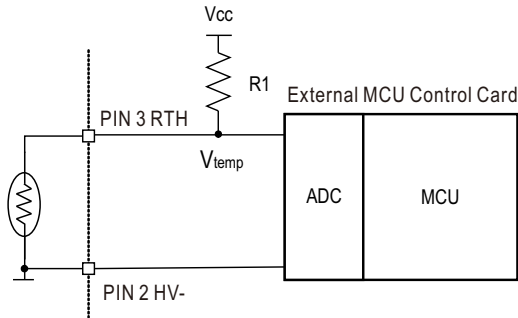

5. Driver Fault signal

The FAULT signal would be active(active-low) to notify external controller or circuit, if VFD-350 encounter the overcurrent state and keep the state for minimum overcurrent tripping time

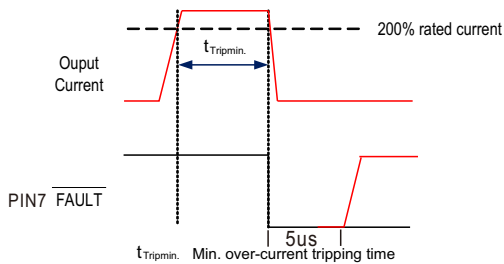

$t_{Tripmin. (Max.)}$	1us
-----------------------	-----

■ Mechanical Specification

Unit:mm

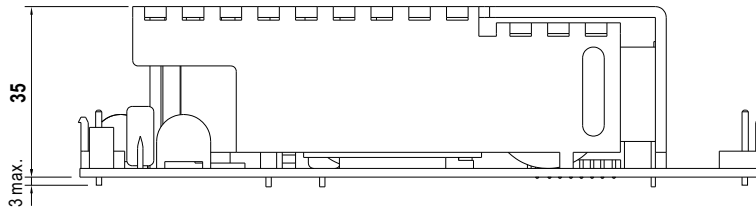
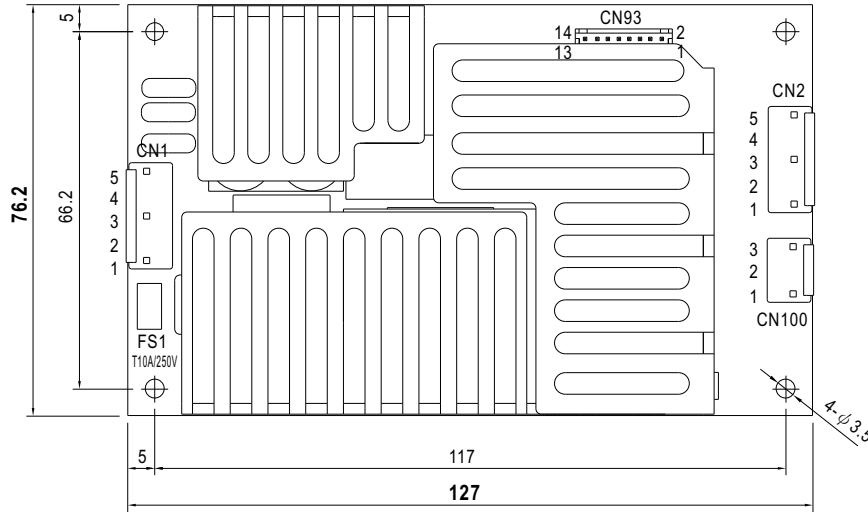

AC Input Connector (CN1) : JST B5P-VH or equivalent

Pin No.	Assignment
1	AC/L
2,4	No Pin
3	AC/N
5	FG \perp

Mating housing: JST VHR or equivalent
Terminal: JST SVH-21T-P1.1 or equivalent

PWM Output Connector(CN2): JST B5P-VH or equivalent

Pin No.	Assignment
1	U
2,4	No Pin
3	V
5	W

Mating housing: JST VHR or equivalent
Terminal: JST SVH-21T-P1.1 or equivalent

380V DC Bus Connector(CN100): JST B3P-VH or equivalent

Pin No.	Assignment
1	DC+
2	No Pin
3	DC-

Mating housing: JST VHR or equivalent
Terminal: JST SVH-21T-P1.1 or equivalent
※ CN100 is used for installing regenerative brake device, avoiding VFD-350P-230 demage.

Control Pin NO. Assignment (CN93) : HRS DF11-14DP-2DS or equivalent

Pin No.	Assignment	Pin No.	Assignment
1	HV+ sensor	8	PWM_W _H
2	HV-	9	PWM_W _L
3	RTH	10	PWM_V _H
4	R _{SH-U}	11	PWM_V _L
5	R _{SH-V}	12	PWM_U _H
6	R _{SH-W}	13	PWM_U _L
7	FAULT	14	VCC

Mating housing: HRS DF11-14DS or equivalent
Terminal HRS DF11-***SC or equivalent

※Control Pin No. Assignment(CN93) :

Pin No.	Function	Description
1	HV+ sensor	DC BUS voltage sensor output 2.5V, reference to pin 2(HV-)
2	HV-	DC BUS voltage sensor output ground
3	RTH	Temperature sensor
4	R _{SH-U}	U phase current sensor output
5	R _{SH-V}	V phase current sensor output
6	R _{SH-W}	W phase current sensor output
7	FAULT	Over current detection. Normal > 3V, Abnormal < 0.5V
8	PWM_W _H	W phase high side logic input, on > 2.6V ; off < 0.8V
9	PWM_W _L	W phase low side logic input, on > 2.6V ; off < 0.8V
10	PWM_V _H	V phase high side logic input, on > 2.6V ; off < 0.8V
11	PWM_V _L	V phase low side logic input, on > 2.6V ; off < 0.8V
12	PWM_U _H	U phase high side logic input, on > 2.6V ; off < 0.8V
13	PWM_U _L	U phase low side logic input, on > 2.6V ; off < 0.8V
14	VCC	Auxiliary voltage output 14.5~15.5V reference to pin(HV-). The maximum load current is 0.1A

Application

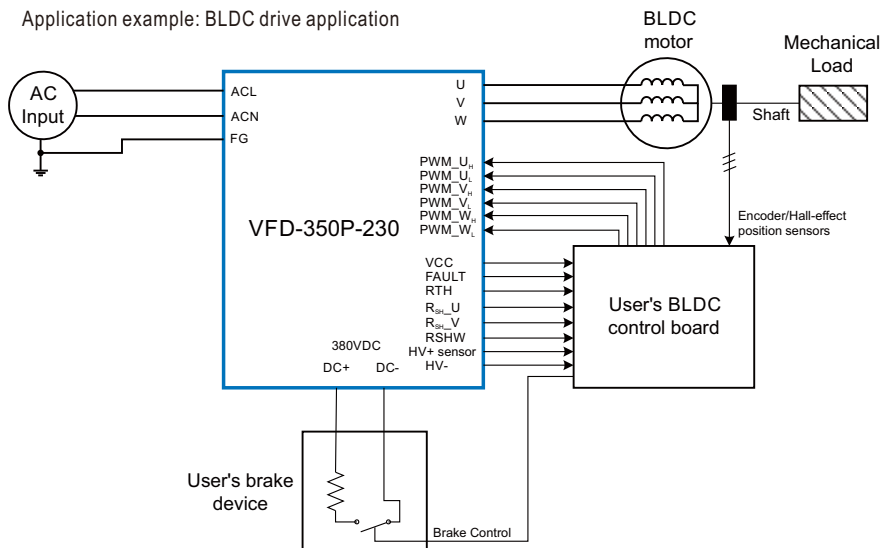

Application example: BLDC drive application



- 1.The figure shows the BLDC drive system which set up with VFD-350P-230.
- 2.Developers can control the PWM signal of 6-switch by using SPWM or SVPWM, etc. for 3-phase voltage modulation, and build the control method base on the current shunt sensors on 3-phase low-side switch(RSHU/V/W) and the DC BUS voltage sensor(HV+ sensor) which provided by VFD-350P-230.
- 3.Developers select the appropriate BLDC position sensors such as encoder or Hall-effect sensors to fit their applications.
- 4.It's suggested to install the brake circuit/device at the DC+/DC- pin(DC BUS) for avoiding the DC BUS OVP when BLDC is decelerating.
- 5.It's suggested to shut down the PWM input or connect to brake resistor device for safety when DC Bus voltage is higher than 420V.
- 6.If VFD-350P-230 were applied non-appropriate control, such as accelerating too quickly or bad current control, it might trig the VFD-350P-230's fault-state to shut down the output voltage(low-level on FAULT pin).

■ Accessory List

If you have any control requirement of specific application, please consult MEAN WELL for more details.

MW's order No.	Control Board	Assembly Suggestion	Quantity
VFD-CB (optional)			1

■ Typical Application

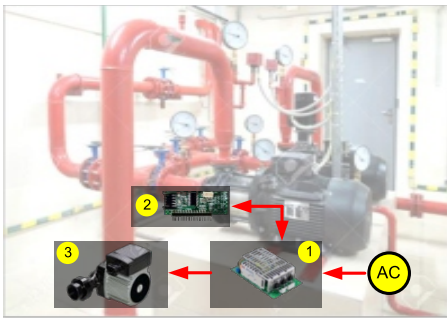

- ① Variable Frequency Module (VFD series)
- ② Control board of Variable Frequency Drive (Designed by User or Solution Provided by MEAN WELL)
- ③ Three-phase Pump Motor

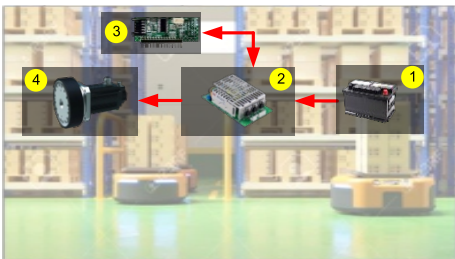

- ① Battery
- ② Variable Frequency Module (VFD series)
- ③ Control board of Variable Frequency Drive (Designed by User or Solution Provided by MEAN WELL)
- ④ Three-phase Wheel Motor for AGV Application

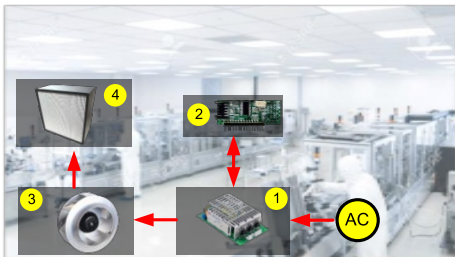

- ① Variable Frequency Module (VFD series)
- ② Control board of Variable Frequency Drive (Designed by User or Solution Provided by MEAN WELL)
- ③ Three-phase Fan Motor
- ④ HEPA for Filtering Air

■ Installation Manual

Please refer to : <http://www.meanwell.com/manual.html>

X-ON Electronics

Largest Supplier of Electrical and Electronic Components

Click to view similar products for [Modular Power Supplies](#) category:

Click to view products by [Mean Well](#) manufacturer:

Other Similar products are found below :

[CURRENTSHARE7LINK](#) [73-317-0005](#) [73-495-0333](#) [OVS-12F](#) [OVS-12J](#) [OVS-15J](#) [IVS13Q2Q1F4LL030ANJCUNR32](#) [LB115S48KH](#)
[OVS-15G](#) [OVS-24F](#) [73-540-0001](#) [DUAL OUTPUT CABLE SET](#) [73-317-0048](#) [73-495-0555](#) [AC6-02C2C-02-R](#) [451-002145-0000](#)
[ACV15N3](#) [CVN300-96P01A](#) [NFN40-7942](#) [SS500-3405-401](#) [VS1-L4-00-CE](#) [MP4-1W-4EE-4NN-00](#) [MP6-3U-00](#) [LFVLT150-1104](#)
[CURRENTSHARE4LINK](#) [CURRENTSHARE8LINK](#) [M5V_40AZ52LL](#) [GXU42V_10A4AJS1](#) [73-450-0001](#) [73-495-0255](#) [73-317-0012](#) [73-](#)
[277-000](#) [BC01108ER](#) [PL1500-12](#) [ML1200-12](#) [MP1-1W-03](#) [D24V_4A2AF-00002](#) [GLD12V_8A3AD-001](#) [M24V_4A2ADTV1](#)
[M24V_8A3AF](#) [M24V_8A3AV1](#) [V60H81P](#) [CM400KS1](#) [VF40FHQY](#) [MP650-3C1EN#](#) [200463](#) [QM502KNP](#) [200464](#) [QM503T7R](#) [V605KJM](#)