

# MLX80020

## Enhanced LIN Transceiver

### Datasheet

## 1. Features

- Compatible to LIN Physical Layer Specification Rev.2.x and SAE J2602
- Baud rate up to 20 kBaud
- Wide operating voltage range  $V_S = 5$  to 27 V
- Very low standby current consumption of 10 $\mu$ A in sleep mode
- Bus and local wake up capable with source recognition
- Control output for voltage regulator with low on – resistance for switchable master termination
- Low EME(emission) and high EMI(immunity) level
- Fully compatible to 3.3V and 5V devices
- Integrated termination resistor for LIN slave nodes
- TxD dominant time out function
- Sleep timer to guarantee the most power saving mode after power on or wake up in case of faulty passive microcontroller
- High impedance Bus pin in case of loss of ground and undervoltage condition
- Bus short to ground protection
- Enhanced ESD robustness according to IEC 61000-4-2
- RoHs compliant and AECQ-100 qualified

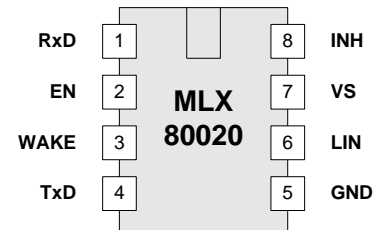

### Ordering Code

Product Code	Temperature Code	Package Code	Option Code	Packing Form Code
MLX80020	K	DC	BBA-000	TU
MLX80020	K	DC	BBA-000	RE
MLX80020	K	DC	BAA-000	TU
MLX80020	K	DC	BAA-000	RE

### Legend:

Temperature Code:	K for Temperature Range -40°C to 125°C
Package Code:	DC for SOIC150Mil
Option Code:	BBA-000 for SAE J2602, BAA-000 for LIN 2.x
Packing Form:	RE for Reel, TU for Tube

Ordering example: MLX80020KDC-BBA-000-TU

## 2. General Description

The MLX80020 is a physical layer device for a single wire data link capable of operating in applications using baud rates from 1kBd to 20kBd. The MLX80020 is compatible to LIN2.x as well as to the SAE J2602 specifications.

Because of the very low power consumption of the MLX80020 in the sleep mode it's suitable for ECU applications with hard standby current requirements. The implemented high resistive termination in sleep mode as well as the driving capability of the INH pin allows a comfortable handling of LIN short circuits to GND. In order to reduce the power consumption in case of failure modes, the integrated sleep timer takes care for switching the ECU into the most power saving sleep mode after power on or wake up events that are not followed by a mode change response of the microcontroller.

The MLX80020 has an improved EMI performance and ESD robustness. The MLX80020 version with the ordering code extension 'A' is suitable for applications with baud rates up to 20kbD. The version of the MLX80020 with the ordering code extension 'B' is optimized for baud rates up to 10.4kbD as specified in the SAE J2602 standard.

## Contents

<b>1. Features</b> .....	<b>1</b>
<b>2. General Description</b> .....	<b>1</b>
<b>3. List of Figures</b> .....	<b>3</b>
<b>4. Functional Diagram</b> .....	<b>4</b>
<b>5. Pin Description</b> .....	<b>5</b>
<b>6. Electrical Specification</b> .....	<b>6</b>
6.1. Operating Conditions .....	6
6.2. Absolute Maximum Ratings .....	6
6.3. Static Characteristics .....	7
6.4. Dynamic Characteristics .....	9
<b>7. Functional Description</b> .....	<b>10</b>
7.1. Operating Modes .....	10
7.2. Initialization and Standby mode .....	11
7.3. Normal Mode .....	11
7.3.1. RxD .....	11
7.3.2. TxD .....	11
7.3.3. TxD dominant time-out feature .....	11
7.3.4. EN .....	11
7.3.5. Data transmission speed .....	12
7.3.6. Duty cycle calculation LIN 2.x .....	12
7.3.7. Duty cycle calculation J2602:.....	13
7.4. Sleep Mode.....	14
7.5. Wake Up .....	14
7.6. Wake Up Source Recognition.....	14
<b>8. Fail-safe features</b> .....	<b>16</b>
8.1. Loss of battery .....	16
8.2. Loss of Ground .....	16
8.3. Short circuit to battery .....	16
8.4. Short circuit to ground .....	16
8.5. Thermal overload .....	16
8.6. Undervoltage lock out .....	16
8.7. Open Circuit protection.....	16
<b>9. Application Hints</b> .....	<b>17</b>
9.1. Application Circuitry .....	17
<b>10. Mechanical Specification SOIC8</b> .....	<b>18</b>
<b>11. Tape and Reel Specification</b> .....	<b>19</b>
11.1. Tape Specification .....	19
11.2. Reel Specification .....	20

12. ESD/EMC Remarks.....	21
12.1. General Remarks .....	21
12.2. ESD-Test.....	21
12.3. EMC .....	21
13. Standard information regarding manufacturability of Melexis products with different soldering processes	22
14. Revision History.....	23
15. Contact .....	24
16. Disclaimer.....	24

### 3. List of Figures

Figure 1: Block Diagram .....	4
Figure 2: Pin description SOIC8 package .....	5
Figure 3: State Diagram of the MLX80020 .....	10
Figure 4 - Duty cycle measurement and calculation in accordance to LIN physical layer specification 2.x for baud rates up to 20Kbps.....	12
Figure 5 - Duty cycle measurement and calculation in accordance to LIN physical layer specification 2.x for baud rates of 10.4Kbps or below.....	13
Figure 6: Remote wake-up behavior .....	15
Figure 7: Application Circuitry .....	17

## 4. Functional Diagram

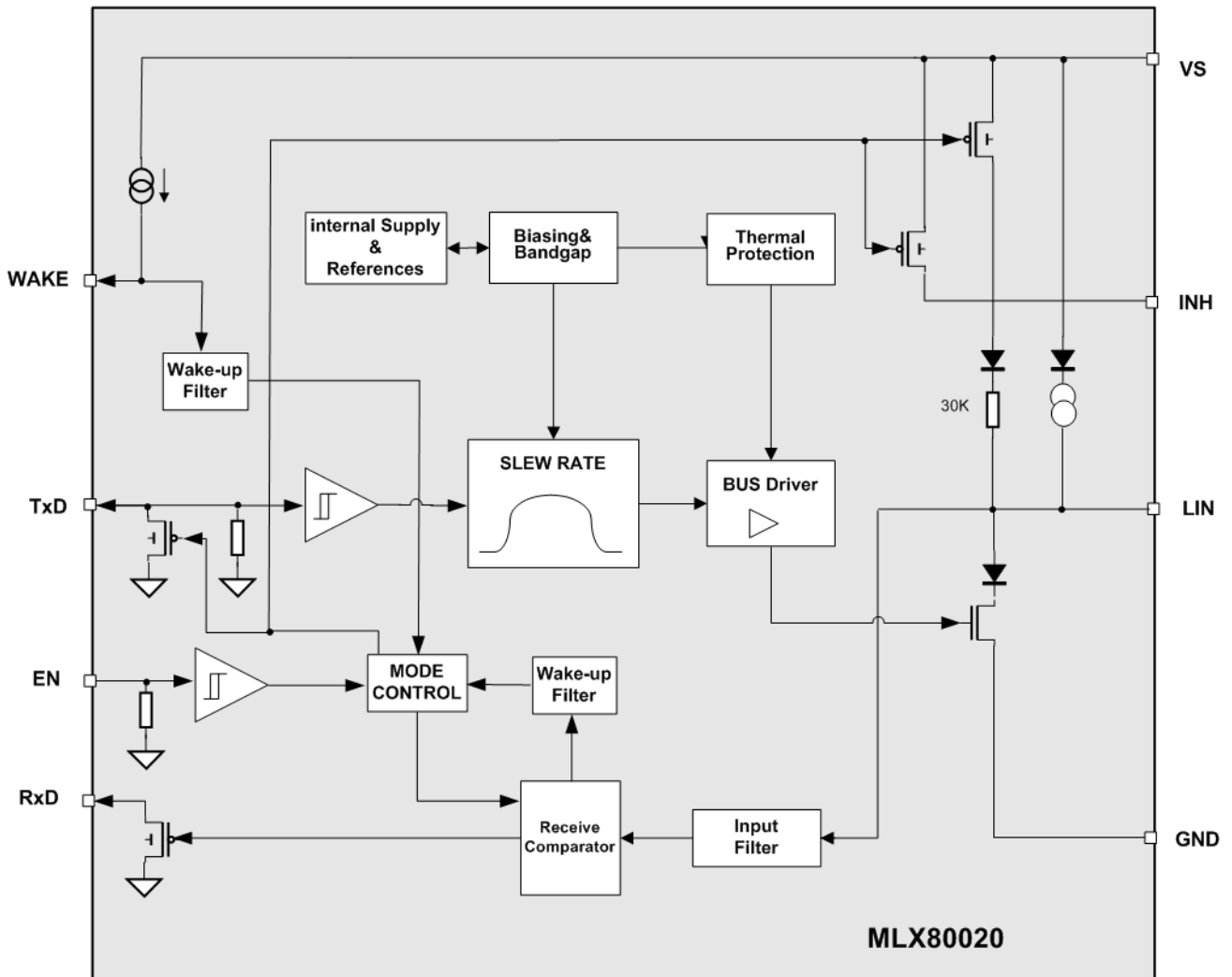
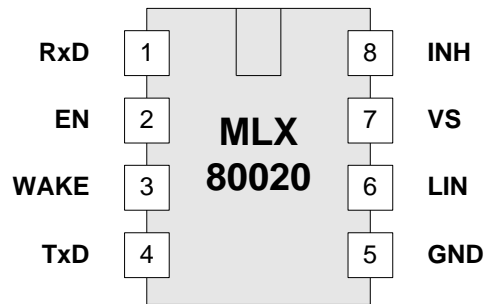

Figure 1: Block Diagram

## 5. Pin Description



*Figure 2: Pin description SOIC8 package*

Pin	Name	IO-Type	Description
1	RXD	O	Received data from LIN bus, LOW in dominant state
2	EN	I	Mode control pin, enables the normal operation mode when HIGH
3	WAKE	I	High voltage input for local wake up, negative edge triggered
4	TXD	I/O	Transmit data input (LOW = dominant), active low after local wake up
5	GND	G	Ground
6	BUS	I/O	LIN bus transmitter/receiver pin, (LOW = dominant)
7	VS	P	Battery supply voltage
8	INH	O	Control output for voltage regulator, termination pin for master pull up

## 6. Electrical Specification

All voltages are referenced to ground (GND). Positive currents flow into the IC.

### 6.1. Operating Conditions

Parameter	Symbol	Min	Max	Unit
Battery supply voltage <sup>[1]</sup>	$V_S$	7	18	V
High battery supply voltage	$V_{S\_S}$	18	27	V
Low battery supply voltage	$V_{S\_L}$	5	7	V
Operating ambient temperature	$T_{amb}$	-40	+125	°C

[1]  $V_S$  is the IC supply voltage including voltage drop of reverse battery protection diode,  $V_{DROP} = 0.4$  to  $1V$ ,  $V_{BAT\_ECU}$  voltage range is 8 to 18V

### 6.2. Absolute Maximum Ratings

In accordance with the Maximum Rating System (IEC 60134). The absolute maximum ratings given in the table below are limiting values that do not lead to a permanent damage of the device but exceeding any of these limits may do so. Long term exposure to limiting values may affect the reliability of the device.

Parameter	Symbol	Condition	Min	Max	Unit
Battery Supply Voltage	$V_S$	Respective to GND	-0.3	40	V
Transients at battery supply voltage	$V_{VS.tr1}$	ISO 7637/2 pulse 1 <sup>[1]</sup>	-100		V
Transients at battery supply voltage	$V_{VS.tr2}$	ISO 7637/2 pulse 2 <sup>[1]</sup>		75	V
Transients at high voltage signal pins	$V_{LIN.tr1}$	ISO 7637/3 pulses 1 <sup>[2]</sup>	-30		V
Transients at high voltage signal pins	$V_{LIN.tr2}$	ISO 7637/3 pulses 2 <sup>[2]</sup>		30	V
Transients at high voltage signal and power supply pins	$V_{HV.tr3}$	ISO 7637/2 pulses 3A, 3B <sup>[3]</sup>	-150	100	V
DC voltage LIN, WAKE	$V_{LIN\_DC}$	Respective to GND and $V_S$ Loss of Ground ( $V_{GND}=V_S$ )	-27	40	V
DC voltage INH	$V_{INH\_DC}$		-0.3	$V_S + 0.3$	V
DC voltage low voltage I/O's (RxD,TxD,EN)	$V_{IV\_DC}$		-0.3	7	V
ESD voltage	$V_{ESD\_IEC}$	IEC 61000-4-2 Pin LIN, VS,to GND, WAKE	-6	6	kV
	$V_{ESD\_HBM}$	HBM (AEC-Q100-002) Pin LIN, VS to GND, WAKE, INH	-8	8	kV
		All other pins	-2	2	kV
	$V_{ESD\_CDM}$	CDM (AEC-Q100-011)	-1000	1000	V

Parameter	Symbol	Condition	Min	Max	Unit
Maximum latch - up free current at any Pin	$I_{LATCH}$		-500	500	mA
Thermal impedance	$\Theta_{JA}$	in free air		152	K/W
Storage temperature	$T_{stg}$		-55	150	°C
Junction temperature	$T_{vj}$		-40	150	°C

- [1] ISO 7637/2 test pulses are applied to VS via a reverse polarity diode and >2uF blocking capacitor.  
 [2] ISO 7637/3 test pulses are applied to LIN via a coupling capacitance of 100nF.  
 [3] ISO 7637/3 test pulses are applied to LIN via a coupling capacitance of 1nF. ISO 7637/2 test pulses are applied to VS via a reverse polarity diode and >10uF blocking capacitor

### 6.3. Static Characteristics

Unless otherwise specified all values in the following tables are valid for  $V_S = 5$  to 27V and  $T_J = -40$  to 150°C. Typical values are valid for  $V_S = 12V$  and  $T_{AMB} = 25^\circ C$ . All voltages are referenced to ground (GND), positive currents are flow into the IC.

Parameter	Symbol	Condition	Min	Typ	Max	Unit
<b>PIN VS</b>						
Power on reset	$V_{S\_POR}$		2.4		4.8	V
Power on reset hysteresis	$V_{S\_POR\_hys}$		0.1	0.3	0.7	V
Undervoltage lockout	$V_{S\_UV}$		4.2		4.9	V
Undervoltage lockout hysteresis	$V_{S\_UV\_hys}$		0.1	0.3	0.7	V
Supply current, sleep mode	$I_{Ssl}$	$V_{EN} = 0V,$ $V_{WAKE} = V_S = V_{LIN} < 14V$	3	9	20	μA
Supply current standby mode	$I_{SBy}$	$V_{EN} = 0V,$ after POR or WU	300	800	2000	μA
Supply current normal mode, dominant	$I_{Sd}$	$V_{EN} = 5V, V_{TXD} = 0V$	1	3	5	mA
Supply current normal mode, recessive	$I_{Sr}$	$V_{EN} = 5V, V_{TXD} = 5V$	300	800	2000	μA
<b>PIN LIN – Transmitter</b>						
Short circuit bus current	$I_{BUS\_LIM}$	$V_{LIN} = V_S, V_{EN} = 5V, V_{TXD} = 0V$	40		200	mA
Pull up resistance bus, normal & standby mode	$R_{SLAVE}$		20		60	kΩ
Pull up current bus, sleep mode	$I_{BUS\_SLEEP}$	$V_{LIN} = 0, V_S = 12V, V_{EN} = 5V,$ $V_{TXD} = 5V$	-100		-20	μA
Input Leakage current at the receiver incl. pull-up resistor	$I_{BUS\_PAS\_dom}$	$V_{LIN} = 0V, V_S = 12V, V_{EN} = 5V,$ $V_{TXD} = 5V$	-600			μA
Bus reverse current, recessive	$I_{BUS\_PAS\_rec}$	$V_{LIN} = 18V, V_S = 5V, V_{EN} = 5V,$ $V_{TXD} = 5V, T_{amb} < 125^\circ C$			20	μA
Bus reverse current loss of battery <sup>[2]</sup>	$I_{BUS\_NO\_BAT}$	$V_S = 0V, 0V < V_{LIN} < 18V$ $T_{amb} < 125^\circ C$			20	μA
Bus current during loss of ground <sup>[2]</sup>	$I_{BUS\_NO\_GND}$	$V_S = 12V,$ $0 < V_{LIN} < 18V$	-100		20	μA
Transmitter dominant voltage <sup>[2]</sup>	$V_{oIBUS}$	$R_{load} = 500\Omega$	0		0.2 $V_S$	V
Transmitter recessive voltage <sup>[2]</sup>	$V_{ohBUS}$	No load, $V_{EN} = 0/5V, V_{TXD} = 5V$	0.8 $V_S$		$V_S$	V
BUS input capacitance <sup>[1]</sup>	$C_{BUS}$	Pulse response via 10kΩ, $V_{PULSE} = 12V, V_S$ open		25	35	pF

Parameter	Symbol	Condition	Min	Typ	Max	Unit
Voltage drop serial Diode <sup>[3]</sup>	V <sub>SerDiode</sub>		0.4		1.0	V
<b>PIN LIN – Receiver</b>						
Receiver dominant voltage	V <sub>iLIN</sub>				0.4 *V <sub>S</sub>	V
Receiver recessive voltage	V <sub>ihLIN</sub>		0.6 *V <sub>S</sub>			V
Center point of receiver threshold	V <sub>iLIN_cnt</sub>	V <sub>LIN_cnt</sub> = ( V <sub>iLIN_</sub> + V <sub>ihLIN</sub> )/2	0.475 *V <sub>S</sub>	0.5 *V <sub>S</sub>	0.525 *V <sub>S</sub>	V
Receiver hysteresis	V <sub>iLIN_hys</sub>	V <sub>LIN_cnt</sub> = ( V <sub>ihLIN</sub> -V <sub>iLIN</sub> )			0.175 *V <sub>S</sub>	V
<b>PIN EN</b>						
High level input voltage	V <sub>ih_EN</sub>	Rising edge	2			V
Low level input voltage	V <sub>il_EN</sub>	Falling edge			0.8	V
Hysteresis	V <sub>ihys_EN</sub>		0.05	0.1	0.3	V
Pull down resistor	R <sub>pd_EN</sub>	V <sub>EN</sub> = 5V	100	350	600	kΩ
Leakage Current	V <sub>leak_EN</sub>	V <sub>EN</sub> = 0V	-5		5	μA
<b>PIN TxD</b>						
High level input voltage	V <sub>ih_TxD</sub>	Rising edge	2			V
Low level input voltage	V <sub>il_TxD</sub>	Falling edge			0.8	V
Hysteresis	V <sub>ihys_TxD</sub>		0.05	0.1	0.3	V
Pull down resistor	R <sub>pd_TxD</sub>	V <sub>TxD</sub> = 5V	100	350	600	kΩ
Low level output voltage	V <sub>ol_rxd</sub>	I <sub>TxD</sub> = 2mA			0.4	V
Leakage Current	V <sub>leak_TxD</sub>	V <sub>TxD</sub> = 0V	-5		5	μA
<b>PIN RXD</b>						
Low level output voltage	V <sub>ol_rxd</sub>	I <sub>RxD</sub> = 2mA			0.4	V
Leakage Current high	V <sub>leak_rxd</sub>	V <sub>RxD</sub> = 5V, V <sub>TxD</sub> = 5V, V <sub>EN</sub> = 5V	-5		5	μA
Leakage Current low	V <sub>leak_rxd</sub>	V <sub>RxD</sub> = 0V, V <sub>TxD</sub> = 5V, V <sub>EN</sub> = 5V	-5		5	μA
<b>PIN INH</b>						
On resistance INH	R <sub>on_INH</sub>	Normal or standby mode, V <sub>INH</sub> = V <sub>S</sub> -1V, V <sub>S</sub> = 12V		20	50	Ω
Leakage current INH high	I <sub>INH_ik</sub>	EN = L, V <sub>INH</sub> = 27V, V <sub>S</sub> = 27V	-5		5	μA
Leakage current INH low	I <sub>INH_lk</sub>	EN = L, V <sub>INH</sub> = 0V, V <sub>S</sub> = 27V	-5		5	μA
<b>PIN WAKE</b>						
High level input voltage	V <sub>ih_WK</sub>		V <sub>S</sub> -1V			V
Low level input voltage	V <sub>il_WK</sub>				V <sub>S</sub> -3.3V	V
Leakage current WAKE high	I <sub>WAKE_ik</sub>	V <sub>WAKE</sub> = 27V, V <sub>S</sub> = 27V	-5		5	μA
Pull up current WAKE	I <sub>WAKE_pu</sub>		-30	-20	-1	μA
<b>Thermal Protection</b>						
Thermal shutdown	T <sub>sd</sub> <sup>[1]</sup>		155	170	190	°C
Thermal hysteresis	T <sub>hys</sub> <sup>[1]</sup>			10	30	°C

[1] No production test, guaranteed by design and qualification  
 [2] In accordance to SAE J2602  
 [3] Guaranteed by design



## 6.4. Dynamic Characteristics

Unless otherwise specified all values in the following table are valid for  $V_S = 5$  to 27V and  $T_{AMB} = -40$  to 125°C.

Parameter	Symbol	Condition	Min	Typ	Max	Unit
Propagation delay receiver <sup>[1]</sup>	$t_{rec\_pdf}$	$C_{RXD} = 25pF$ falling edge			6	$\mu s$
Propagation delay receiver <sup>[1]</sup>	$t_{rec\_pdr}$	$C_{RXD} = 25pF$ rising edge			6	$\mu s$
Propagation delay receiver symmetry	$t_{rec\_sym}$	Calculate $t_{rec\_pdf} - t_{rec\_pdr}$	-2		2	$\mu s$
Receiver debounce time <sup>[2]</sup>	$t_{rec\_deb}$	LIN rising & falling edge	0.5		4	$\mu s$
LIN duty cycle 1 <sup>[2] [3] [4]</sup>	D1	20kbps operation ,	0.396			
LIN duty cycle 2 <sup>[2] [3] [4]</sup>	D2	20kbps operation ,			0.581	
LIN duty cycle 3 <sup>[2] [3]</sup>	D3		0.417			
LIN duty cycle 4 <sup>[2] [3]</sup>	D4				0.590	
$t_{rec(max)} - t_{dom(min)}$ <sup>[5]</sup>	$\Delta t3$				15.9	$\mu s$
$t_{rec(min)} - t_{dom(max)}$ <sup>[5]</sup>	$\Delta t4$				17.28	$\mu s$
Remote Wake-up filter time	$t_{wu\_remote}$	sleep mode, LIN rising & falling edge	30		150	$\mu s$
Local Wake-up filter time	$t_{wu\_local}$	sleep mode, WAKE falling edge	10		50	$\mu s$
Delay from Standby to Sleep Mode	$t_{dsleep}$	$V_{EN} = 0$	150		500	ms
TxD dominant time out time	$t_{TXD\_to}$	normal mode, $V_{TXD} = 0$	27		60	ms
EN – debounce time	$t_{EN\_deb}$	normal <--> standby mode transitions	0.5		4	$\mu s$

- [1] This parameter is tested by applying a square wave signal to the LIN. The minimum slew rate for the LIN rising and falling edges is 50V/us  
 [2] See figure 5 – LIN timing diagram  
 [3] Standard loads for duty cycle measurements are 1K $\Omega$ /1nF, 660 $\Omega$ /6.8nF, 500 $\Omega$ /10nF  
 [4] Not valid for the SAE J2602 version (optimized for 10.4kBd operation) of the MLX80020 xA  
 [5] In accordance to SAE J2602, only for device version MLX80020 xB

## 7. Functional Description

### 7.1. Operating Modes

Mode	EN	TxD	RxD	INH	Transmitter	Remarks
Standby	0	weak pull down/active low <sup>[1]</sup>	floating/active low <sup>[2]</sup>	V <sub>S</sub>	off	entered after power on or wake up
Normal mode	1	weak pull down/input for transmit data stream	output for LIN data stream	V <sub>S</sub>	on	[3] [4] [5]
Sleep mode	0	weak pull down	floating	floating	off	No local or remote wake up

- [1] Indicates the wake up flag in case of local wake up  
 [2] After power on RxD is floating. If any wake up(local or remote) occurs it will be indicated by active low  
 [3] Active low interrupt at pin RxD will be removed when entering normal mode  
 [4] Wake up source flag at pin TxD will be removed when entering normal mode  
 [5] Normal mode will be entered by a low -> high transition on pin EN. When recessive level (high) on pin TxD is present the transmit path will be enabled

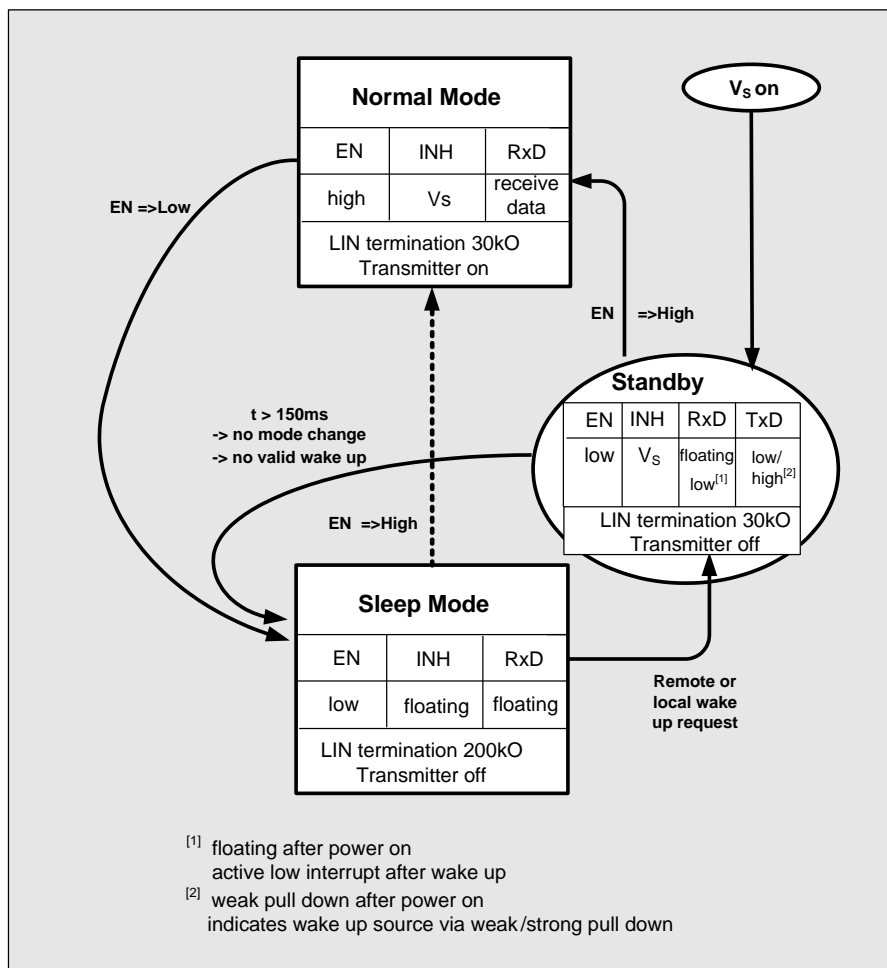

Figure 3: State Diagram of the MLX80020

## 7.2. Initialization and Standby mode

When the battery supply voltage  $V_s$  exceeds the specified threshold  $V_{S\_POR}$ , the MLX80020 automatically enters an intermediate standby mode. The INH output becomes HIGH ( $V_s$ ) and therefore the external voltage regulator will provide the  $V_{cc}$  supply voltage to the ECU. The pin RxD is floating and the integrated slave pull up resistor with decoupling diode secures high level on the pin LIN. The transmitter as well as the receiver is disabled.

If there occurs no mode change to normal mode via an EN LOW to HIGH transition within the time defined (typically 350ms), the IC enters the most power saving sleep mode and the INH output will become floating (logic 0).

Furthermore the standby mode will be entered after a valid local or remote wake up event, when the MLX80020 is in sleep mode. The entering of the standby mode after wake up will be indicated by an active LOW interrupt on pin RxD.

## 7.3. Normal Mode

By entering this mode the MLX80020 can be used as interface between the single wire LIN bus and the microcontroller. The incoming bus traffic is detected by the receiver and transferred via the RxD output pin to the microcontroller. (see figure 3, LIN timing diagram)

### 7.3.1. RxD

The pin *RxD* is a buffered open drain output with a typical load of:

Resistance: 2.7 kOhm  
Capacitance: < 25 pF

The output signal supports by the external pull up resistor 3.3V and 5V supply systems.

### 7.3.2. TxD

The transmit data stream of the LIN protocol controller applied to the pin *TxD* is converted into the LIN bus signal with slew rate control in order to minimize electromagnetic emissions.

The pin *TxD* contains a weak pull down resistor. The input thresholds are compatible to 3.3V and 5V supply systems. To enable the transmit path, the TxD pin has to be driven recessive (HIGH) after or during the normal mode has been entered.

### 7.3.3. TxD dominant time-out feature

By the first dominant level on pin TxD after the transmit path has been enabled, the dominant time-out counter is started. In case of a faulty blocked permanent dominant level on pin TxD the transmit path will be disabled after the specified time  $t_{TxD\_to}$ . The time-out counter is reset by the first negative edge on pin TxD.

### 7.3.4. EN

The normal mode can be entered being in sleep or standby mode, when the pin *EN* is driven HIGH. To prevent unwanted mode transitions, the EN input contains a debounce filter as specified ( $t_{EN\_deb}$ ).

The pin *EN* contains a weak pull down resistor. The input thresholds are compatible to 3.3V and 5V supply systems. Additionally the positive edge on pin EN results in an immediate reset of the active low interrupt on pin RxD as well as the wake-up source recognition flag on pin TxD (see chapter 4.5 Wake Up).

### 7.3.5. Data transmission speed

The MLX80020 is a **constant slew rate** transceiver that means the bus driver operates with a fixed slew rate range independent of the supply voltage. This principle secures a very good symmetry of the slope times between recessive to dominant and dominant to recessive slopes within the LIN bus load range ( $C_{BUS}$ ,  $R_{term}$ ).

The MLX80020 KDC A version guarantees data rates up to 20kbD within the complete bus load range under worst case conditions.

The version MLX80020 KDC B is optimized for applications with a maximum baud rate of 10.4kbD (SAE J2602) in order to minimize EME. These devices can not be used in applications with higher baud rates.

The constant slew rate principle is very robust against voltage drops and can operate with RC- oscillator systems with a clock tolerance up to  $\pm 2\%$  between 2 nodes.

### 7.3.6. Duty cycle calculation LIN 2.x

With the timing parameters shown in the picture below two duty cycles , based on  $t_{rec(min)}$  and  $t_{rec(max)}$  can be calculated as follows :  $t_{Bit} = 50\mu s$

$$D1 = t_{rec(min)} / (2 \times t_{Bit})$$

$$D2 = t_{rec(max)} / (2 \times t_{Bit})$$

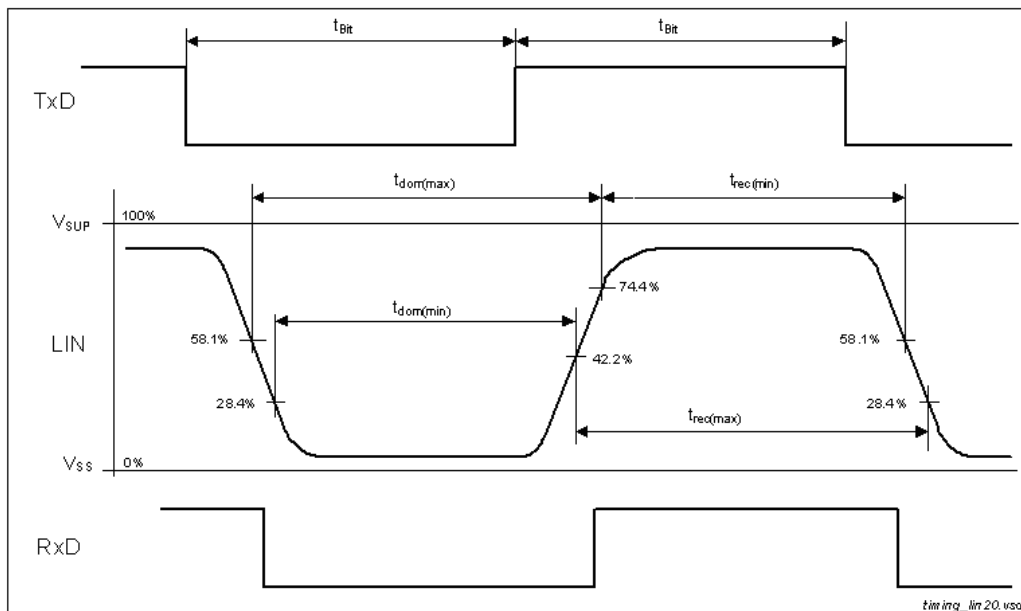

Figure 4 - Duty cycle measurement and calculation in accordance to LIN physical layer specification 2.x for baud rates up to 20Kbps

### 7.3.7. Duty cycle calculation J2602:

With the timing parameters shown in the table below two duty cycles , based on  $t_{rec(min)}$  and  $t_{rec(max)}$  can be calculated as follows :  $t_{Bit} = 96\mu s$

$$D3 = t_{rec(min)} / (2 \times t_{Bit})$$

$$D4 = t_{rec(max)} / (2 \times t_{Bit})$$

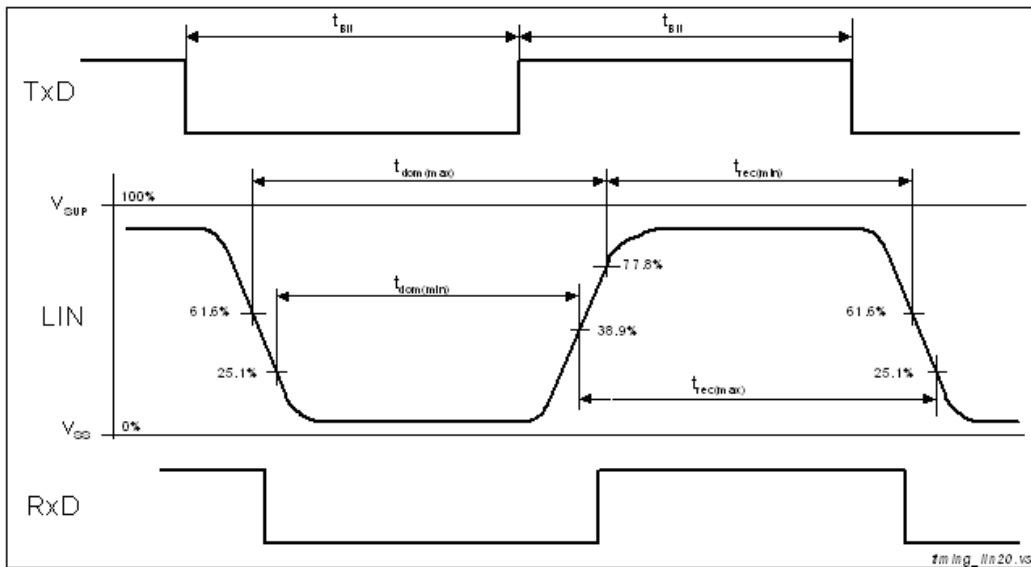

Figure 5 - Duty cycle measurement and calculation in accordance to LIN physical layer specification 2.x for baud rates of 10.4Kbps or below

## 7.4. Sleep Mode

The most power saving mode of the MLX80020 is the sleep mode. The MLX80020 offers two procedures to enter the sleep mode:

- The mode is selected when the pin EN is driven LOW in normal mode for longer than the specified filter time ( $t_{EN\_deb}$ ). The mode change into sleep mode is possible even in case of dominant voltage levels on the LIN bus, pins WAKE or TxD.
- If the MLX80020 is in standby mode after power-on or wake-up, a sleep counter is started and switches the transceiver into sleep mode after the specified time (typ. 350ms) even when the microcontroller of the ECU will not confirm the normal operation by setting the EN pin to logic HIGH. This new feature allows faulty blocked LIN nodes to reach always the most power saving mode.

Being in sleep mode the INH pin becomes floating and the ECU voltage regulator can be switched off in order to minimize the current consumption of the complete LIN node. The transmitter is disabled and the pin RxD is disconnected from the receive path and is floating. The slave termination resistor (LIN pull up resistor with decoupling diode between pins LIN and Vs) is disconnected and only a weak LIN pull up resistor is applied to the LIN bus (see chapter 5.4 fail-safe features)

## 7.5. Wake Up

When in sleep mode the MLX80020 offers three wake-up procedures:

- In applications with continuously powered ECU a wake up via mode transition to normal mode is possible (see chapter 4.3 Normal Mode)
- Remote wake-up via LIN bus traffic  
After a falling edge on the LIN bus followed by a dominant voltage level for longer than the specified value ( $t_{wu\_remote}$ ) and a rising edge on pin LIN will cause a remote wake up (see fig.4 page )
- Local wake-up via a negative edge on pin WAKE  
A negative edge on the pin WAKE and a dominant voltage level for longer than the specified time ( $t_{wu\_local}$ ) will cause a local wake-up. The current for an external switch has to be provided by an external pull up resistor  $R_{WK}$ . For a reverse current limitation in case of a closed external switch and a negative ground shift or an ECU loss of ground a protection resistor  $R_{WK\_prot}$  between pin WAKE and the switch is recommended. (see fig.5 page )  
The pin WAKE provides a weak pull up current towards the battery voltage that provides a HIGH level on the pin in case of open circuit failures or if no local wake up is required. In such applications it is recommended to connect the pin WAKE directly to pin Vs in order to prevent influences due to EMI.

## 7.6. Wake Up Source Recognition

The device can distinguish between a local wake-up event (pin WAKE) and a remote wake-up event. The wake-up source flag is set after a local wake-up event and is indicated by an active LOW on pin TxD.

The wake-up flag can be read if an external pull up resistor towards the microcontroller supply voltage has been added (see fig.5 ) and the MLX80020 is still in standby mode:

- LOW level indicates a local wake-up event
- HIGH level indicates a remote wake up event

The wake-up request is indicated by an active LOW on pin RxD and can be used for an interrupt..

When the microcontroller confirms a normal mode operation by setting the pin EN to HIGH, both the wake-up request on pin RxD as well as the wake-up source flag on pin TxD are reset immediately.

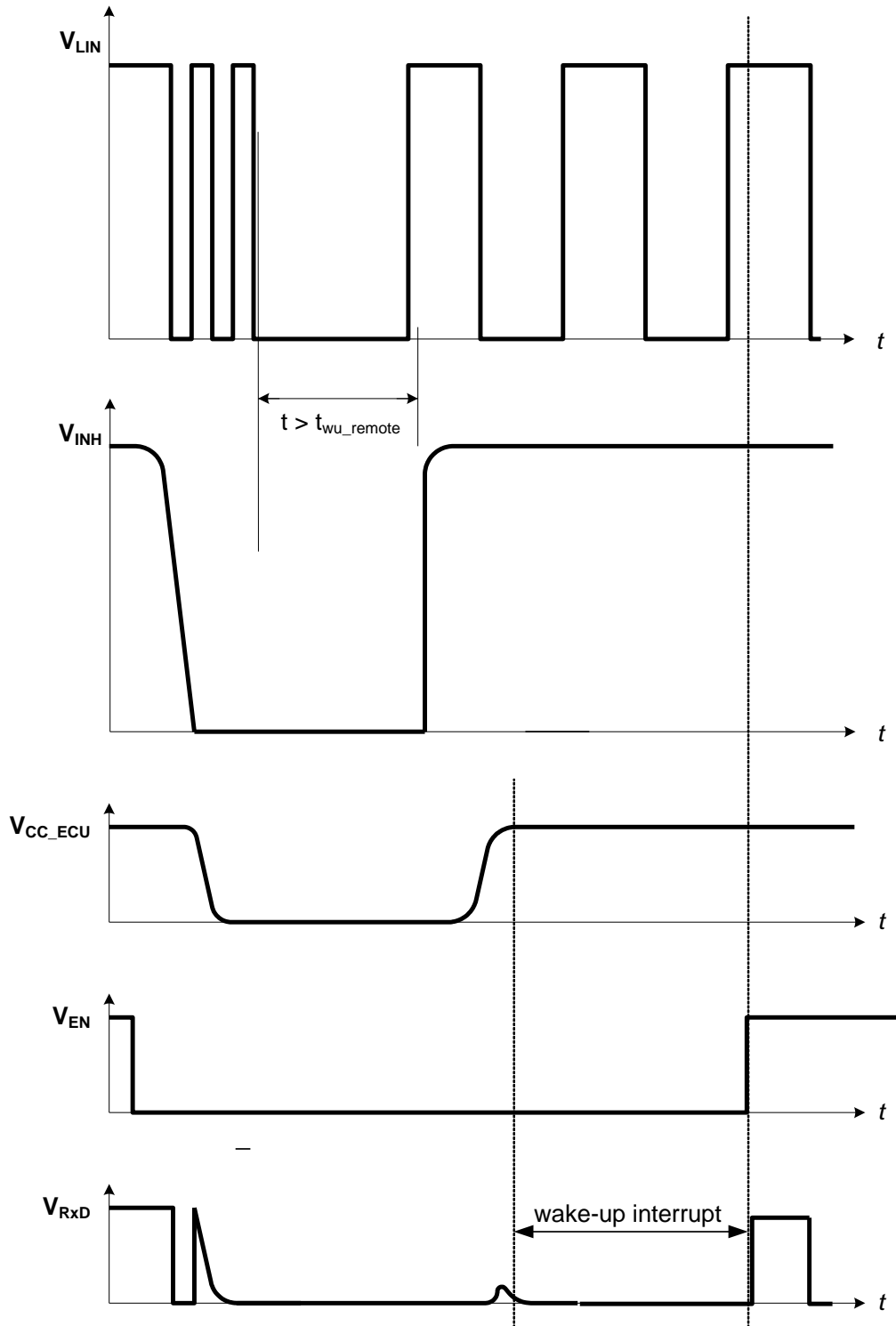

Figure 6: Remote wake-up behavior

## 8. Fail-safe features

### 8.1. Loss of battery

If the ECU is disconnected from the battery, the bus pin is in high impedance state. There is no impact to the bus traffic and to the ECU itself. Reverse current is limited to  $< 20\mu\text{A}$

### 8.2. Loss of Ground

In case of an interrupted ECU ground connection there is no influence to the bus line. The current from the ECU to the LIN bus is limited by the weak pull up resistance of the pin LIN, the slave termination resistor is disconnected in order to fulfill the SAE J2602 requirements for the loss of ground current ( $<100\mu\text{A}$  @12V).

### 8.3. Short circuit to battery

The transmitter output current is limited to the specified value in case of short circuit to battery in order to prevent high current densities and thermal hot spots in the LIN driver.

### 8.4. Short circuit to ground

If the LIN bus wiring is shorted to negative shifted ground levels, there is no current flow from the ECU ground to the bus and no distortion of the bus traffic occurs.

The permanent failure current from battery to ground can be reduced dramatically by using the INH pin as termination control pin for the master pull up resistor (See Figure 7: Application Circuitry).

If the controller detects a short circuit of the LIN bus to ground the transceiver can be set into sleep mode. The INH pin is floating and therefore the master pull up resistor is disconnected from the bus line. Additionally the internal slave termination resistor is switched off and only a weak pull up termination is applied to the LIN bus (typ.  $75\mu\text{A}$ ). If the failure disappears, the bus level will become recessive again and will wake up the system even if no local wake up occurs or is possible.

### 8.5. Thermal overload

The MLX80020 is protected against thermal overloads. If the chip temperature exceeds the specified value, the transmitter is disabled until thermal recovery and the following recessive to dominant transition on pin TxD. The receiver is still working while thermal shutdown.

### 8.6. Undervoltage lock out

If the battery supply voltage is missing or decreased under the specified value ( $V_{S\_UV}$ ), the transmitter is disabled to prevent undefined bus traffic.

### 8.7. Open Circuit protection

- The pin TxD provides a weak pull down. The transmitter can not be enabled.
- The pin EN provides a weak pull down to prevent undefined normal mode transitions.
- If the battery supply voltage is disconnected, the pin RxD is floating
- The pin WAKE provides a weak pull up current towards supply voltage  $V_S$  to prevent local wake-up requests



## 9. Application Hints

### 9.1. Application Circuitry

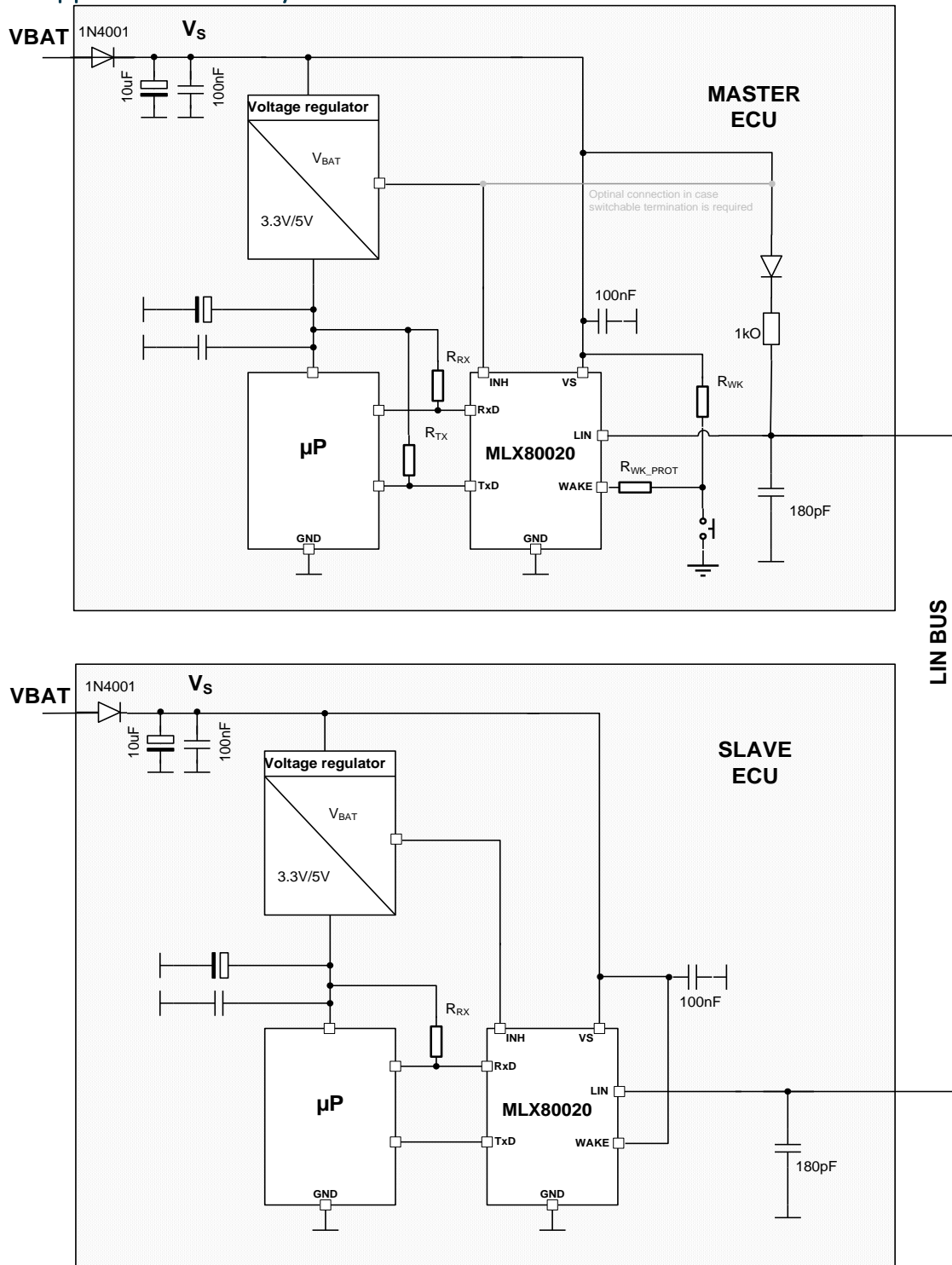
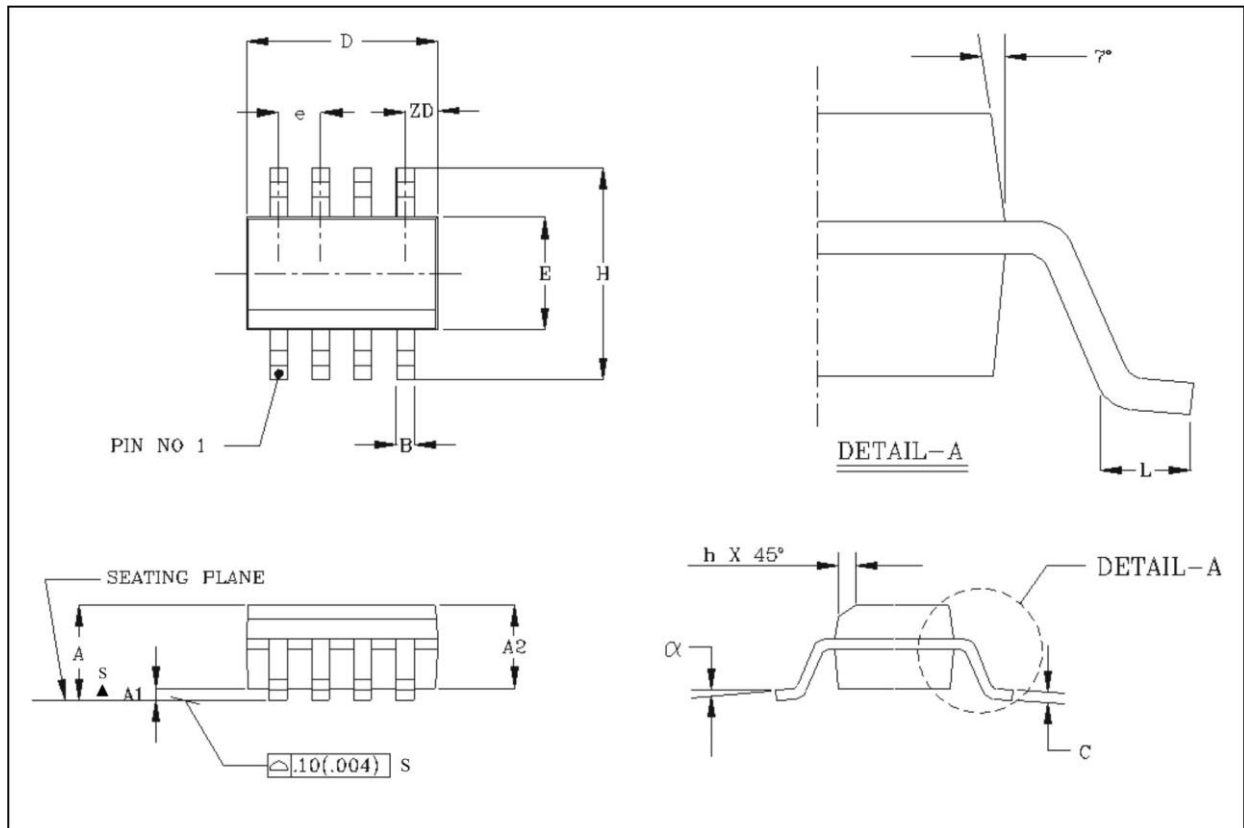

Figure 7: Application Circuitry

## 10. Mechanical Specification SOIC8



Small Outline Integrated Circuit (SOIC), SOIC 8, 150 mil

	A1	B	C	D	E	e	H	h	L	A	$\alpha$	ZD	A2
All Dimension in mm, coplanarity < 0.1 mm													
min	0.10	0.36	0.19	4.80	3.81	1.27	5.80	0.25	0.41	1.52	0°	0.53	1.37
max	0.25	0.46	0.25	4.98	3.99		6.20	0.50	1.27	1.72	8°		1.57
All Dimension in inch, coplanarity < 0.004"													
min	0.004	0.014	0.0075	0.189	0.150	0.050	0.2284	0.0099	0.016	0.060	0°	0.021	0.054
max	0.0098	0.018	0.0098	0.196	0.157		0.244	0.0198	0.050	0.068	8°		0.062

## 11. Tape and Reel Specification

### 11.1. Tape Specification

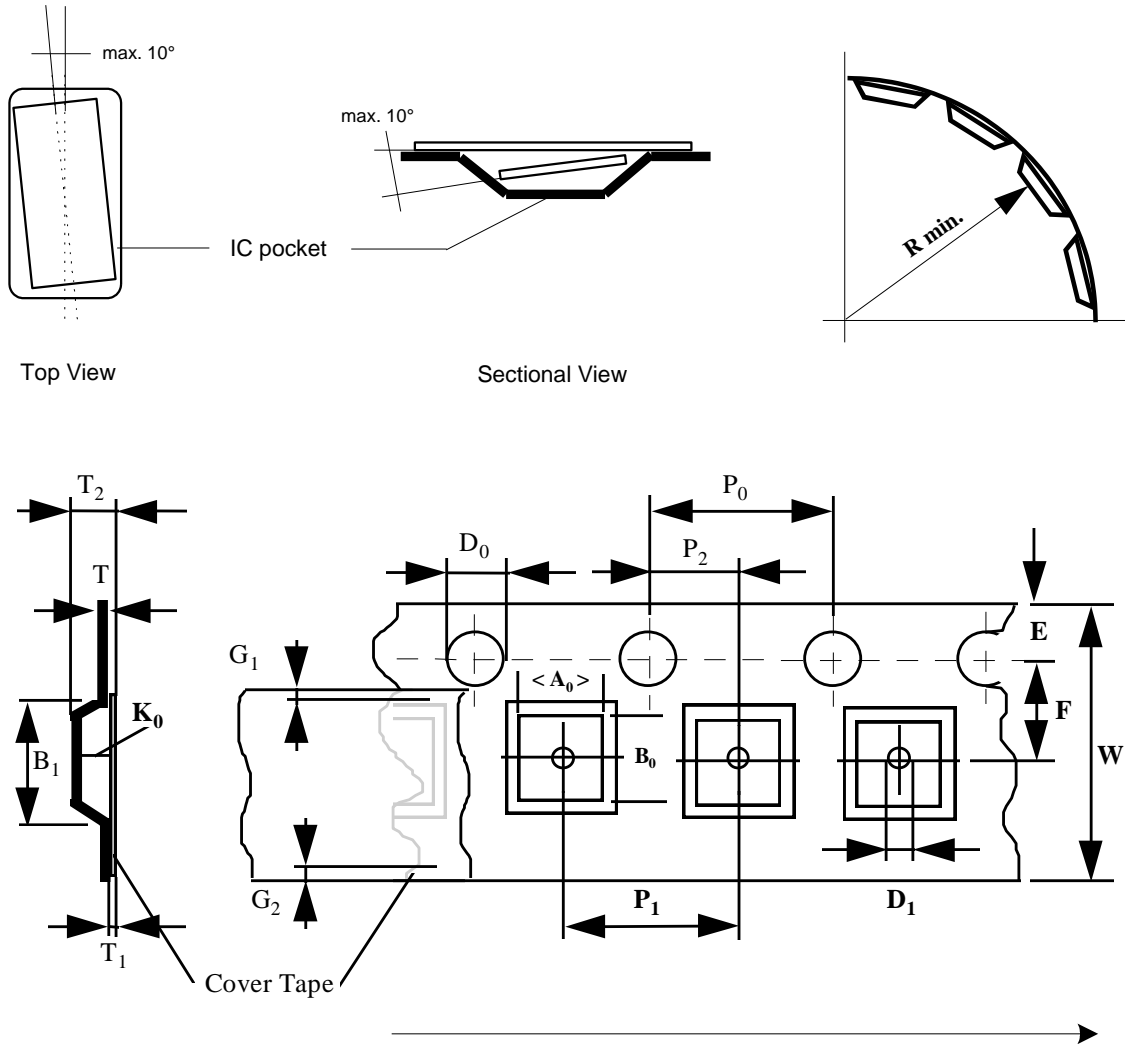

#### Standard Reel with diameter of 13"

Package	Parts per Reel	Width	Pitch
SOIC8	3000	12 mm	8 mm

D <sub>0</sub>	E	P <sub>0</sub>	P <sub>2</sub>	T <sub>max</sub>	T <sub>1 max</sub>	G <sub>1 min</sub>	G <sub>2 min</sub>	B <sub>1 max</sub>	D <sub>1 min</sub>	F	P <sub>1</sub>	R <sub>min</sub>	T <sub>2 max</sub>	W
1.5 +0.1	1.75 ±0.1	4.0 ±0.1	2.0 ±0.05	0.6	0.1	0.75	0.75	8.2	1.5	5.5 ±0.05	4.0 ±0.1	30	6.5	12.0 ±0.3

A<sub>0</sub>, B<sub>0</sub>, K<sub>0</sub> can be calculated with package specification.  
 Cover Tape width 9.2 mm.

## 11.2. Reel Specification

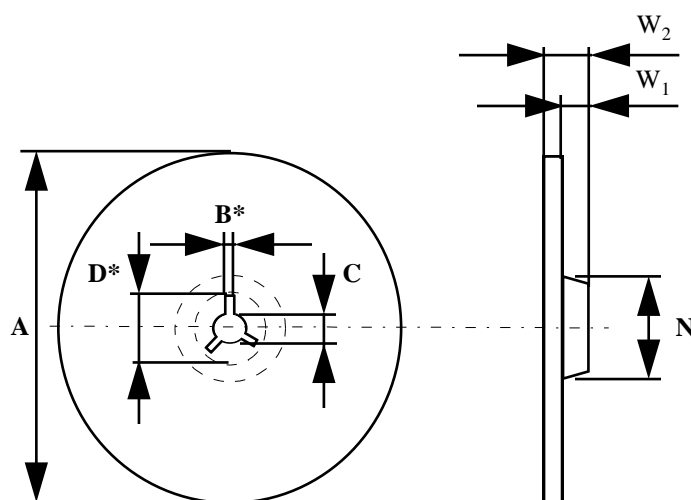

$A_{\max}$	$B^*$	$C$	$D^*_{\min}$
330	$2.0 \pm 0.5$	$13.0 +0,5/-0,2$	20.2
Width of half reel	$N_{\min}$	$W_1$	$W_2_{\max}$
4 mm	100,0	4,4	7,1
8 mm	100,0	8,4	11,1

## 12. ESD/EMC Remarks

### 12.1. General Remarks

Electronic semiconductor products are sensitive to Electro Static Discharge (ESD).  
Always observe Electro Static Discharge control procedures whenever handling semiconductor products.

### 12.2. ESD-Test

The MLX80020 is tested according to HBM AEC-Q100-002.  
The ESD test CDM according to AEC-Q100-011 as well as system level ESD test according to IEC 61000-4-2 are performed by an external test house.

### 12.3. EMC

The test on EMC impacts is done according to ISO 7637-2 for power supply pins and ISO 7637-3 for data and signal pins as well as the "Hardware requirements for LIN, CAN and FlexRay Interfaces in Automotive Applications"; Audi, BMW, Daimler, Porsche, VW; 2009-12-02"

## 13. Standard information regarding manufacturability of Melexis products with different soldering processes

Our products are classified and qualified regarding soldering technology, solderability and moisture sensitivity level according to following test methods:

### **Reflow Soldering SMD's (Surface Mount Devices)**

- IPC/JEDEC J-STD-020  
Moisture/Reflow Sensitivity Classification for Nonhermetic Solid State Surface Mount Devices (classification reflow profiles according to table 5-2)
- EIA/JEDEC JESD22-A113  
Preconditioning of Nonhermetic Surface Mount Devices Prior to Reliability Testing (reflow profiles according to table 2)

### **Wave Soldering SMD's (Surface Mount Devices) and THD's (Through Hole Devices)**

- EN60749-20  
Resistance of plastic- encapsulated SMD's to combined effect of moisture and soldering heat
- EIA/JEDEC JESD22-B106 and EN60749-15  
Resistance to soldering temperature for through-hole mounted devices

### **Iron Soldering THD's (Through Hole Devices)**

- EN60749-15  
Resistance to soldering temperature for through-hole mounted devices

### **Solderability SMD's (Surface Mount Devices) and THD's (Through Hole Devices)**

- EIA/JEDEC JESD22-B102 and EN60749-21  
Solderability

For all soldering technologies deviating from above mentioned standard conditions (regarding peak temperature, temperature gradient, temperature profile etc) additional classification and qualification tests have to be agreed upon with Melexis.

The application of Wave Soldering for SMD's is allowed only after consulting Melexis regarding assurance of adhesive strength between device and board.

Melexis is contributing to global environmental conservation by promoting **lead free** solutions. For more information on qualifications of **RoHS** compliant products (RoHS = European directive on the Restriction Of the use of certain Hazardous Substances) please visit the quality page on our website: <http://www.melexis.com/quality.aspx>

## 14. Revision History

Version	Changes	Remark	Date
001		Initial release	October 2010
002	Changed maximum ratings (ESD value CDM increased) Changed Static Characteristic in acc to CPK-values Changed Chapter 9.3 EMC Changes Tape Specification Chapter 8.1		November 2010
003	Change of Order Code		November 2010
004	Change “short term” to “high” operating range in chapter “Operating Conditions”		June 2011
005	Logo, disclaimer, ordering code		June 2012
006	Electrical Specification of LIN-Transmitter updated		November 2015
007	New branding: colours, font, logo, contact, disclaimer		July 2017

## 15. Contact

For the latest version of this document, go to our website at [www.melexis.com](http://www.melexis.com).

For additional information, please contact our Direct Sales team and get help for your specific needs:

Europe, Africa	Telephone: +32 13 67 04 95
	Email : sales_europe@melexis.com
Americas	Telephone: +1 603 223 2362
	Email : sales_usa@melexis.com
Asia	Email : sales_asia@melexis.com

## 16. Disclaimer

*The information furnished by Melexis herein ("Information") is believed to be correct and accurate. Melexis disclaims (i) any and all liability in connection with or arising out of the furnishing, performance or use of the technical data or use of the product(s) as described herein ("Product") (ii) any and all liability, including without limitation, special, consequential or incidental damages, and (iii) any and all warranties, express, statutory, implied, or by description, including warranties of fitness for particular purpose, non-infringement and merchantability. No obligation or liability shall arise or flow out of Melexis' rendering of technical or other services.*

*The Information is provided "as is" and Melexis reserves the right to change the Information at any time and without notice. Therefore, before placing orders and/or prior to designing the Product into a system, users or any third party should obtain the latest version of the relevant information to verify that the information being relied upon is current.*

*Users or any third party must further determine the suitability of the Product for its application, including the level of reliability required and determine whether it is fit for a particular purpose.*

*The Information is proprietary and/or confidential information of Melexis and the use thereof or anything described by the Information does not grant, explicitly or implicitly, to any party any patent rights, licenses, or any other intellectual property rights.*

*This document as well as the Product(s) may be subject to export control regulations. Please be aware that export might require a prior authorization from competent authorities.*

*The Product(s) are intended for use in normal commercial applications. Unless otherwise agreed upon in writing, the Product(s) are not designed, authorized or warranted to be suitable in applications requiring extended temperature range and/or unusual environmental requirements. High reliability applications, such as medical life-support or life-sustaining equipment are specifically not recommended by Melexis.*

*The Product(s) may not be used for the following applications subject to export control regulations: the development, production, processing, operation, maintenance, storage, recognition or proliferation of 1) chemical, biological or nuclear weapons, or for the development, production, maintenance or storage of missiles for such weapons; 2) civil firearms, including spare parts or ammunition for such arms; 3) defense related products, or other material for military use or for law enforcement; 4) any applications that, alone or in combination with other goods, substances or organisms could cause serious harm to persons or goods and that can be used as a means of violence in an armed conflict or any similar violent situation.*

*The Products sold by Melexis are subject to the terms and conditions as specified in the Terms of Sale, which can be found at <https://www.melexis.com/en/legal/terms-and-conditions>.*

*This document supersedes and replaces all prior information regarding the Product(s) and/or previous versions of this document.*

*Melexis NV © - No part of this document may be reproduced without the prior written consent of Melexis. (2016)*

*ISO/TS 16949 and ISO14001 Certified*



## X-ON Electronics

Largest Supplier of Electrical and Electronic Components

*Click to view similar products for [LIN Transceivers](#) category:*

*Click to view products by [Melexis](#) manufacturer:*

Other Similar products are found below :

[MC34910G5AC](#) [BCM54685EB2KPBG](#) [BCM8727CIFBG](#) [MC33911BAC](#) [MCH3308-TL-E](#) [CS5536AD B1](#) [MAX13021ASA/V+T](#)  
[MLX80004KLW-BAA-001-SP](#) [BCM54210B0IMLG](#) [NCV7422MW0R2G](#) [NCV7329MW0R2G](#) [MC33662JEFR2](#) [MCP2003B-H/MC](#)  
[MCP2021T-500E/MD](#) [MCP2021A-500EMD](#) [MCP2050-330E/MQ](#) [MCP2050-500E/MQ](#) [BCM5248UA4KQMG](#) [AMIS30600LINI1RG](#)  
[ATA6614Q-PLQW](#) [ATA6626C-PGPW](#) [TLE8457ASJXUMA1](#) [MC33399PEFR2](#) [MC33399PEF](#) [MC1488MELG](#) [NCN5150DR2G](#)  
[MAX13021ASA/V+](#) [MAX13020ASA+](#) [NCV7425DW0R2G](#) [DF3052BF25V](#) [TJA1021T/20/CM,118](#) [MCP2021T-500E/SN](#) [MCP2021P-](#)  
[330E/MD](#) [MCP2003B-H/SN](#) [MCP2021P-330E/SN](#) [MCP2022P-330E/ST](#) [MCP2004T-E/SN](#) [MCP2022P-500E/SL](#) [MCP2021P-500E/SN](#)  
[MCP2003BT-H/SN](#) [MCP2022P-330E/SL](#) [SP3508EB](#) [ADM3072EARZ](#) [ADM3311EARUZ](#) [TJA1027T/20,118](#) [MC33662LEF](#)  
[MC33910G5AC](#) [MC33911G5AC](#) [MC33912G5AC](#) [MD-002HRL](#)