

# MLX90109

125kHz RFID Transceiver

## Features and Benefits

- Integrated RFID transceiver  
Addressing 100kHz to 150kHz frequency range transponder.  
Biphase and Manchester ASK.  
ON/OFF keying modulation.
- Low Power and high performances  
Unique Parallel Antenna concept for maximum power efficiency.  
Power down mode available.  
Baud rate selectable “on-chip” filtering for maximum sensitivity.  
No zero modulation problems.
- Low cost and compact design  
SO8 package and high level of integration for compact reader design.  
No external quartz reference required, only 2 resistors plus antenna.  
On chip decoding for fast system design and ease of use.  
Open drain data and clock outputs for 2-wire serial communication.

## Applications Examples

- Car Immobilizers
- Portable readers
- Access control
- House held appliances

## Ordering Code

Product Code	Temperature Code	Package Code	Option Code	Packing Form Code
MLX90109	E	DC	AAA-000	RE
MLX90109	E	DC	AAA-000	TU
MLX90109	C	DC	AAA-000	RE
MLX90109	C	DC	AAA-000	TU

### **Legend:**

Temperature Code: E for Temperature Range -40°C to 85°C  
C for Temperature Range 0°C to 70°C

Package Code: DC for SOIC150Mil

Packing Form: RE for Reel, TU for Tube

Ordering example: MLX90109EDC-AAA-000-RE

## 1. Functional diagram

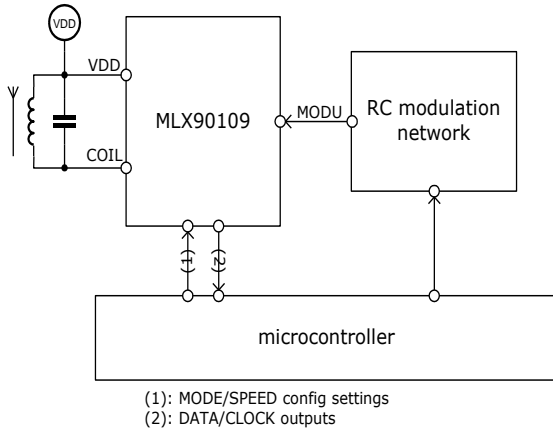

## 2. Description

The MLX90109 is a single chip RFID transceiver for the 125kHz frequency range. It has been conceived for minimum system cost and minimum power consumption, offering all required flexibility for a state of the art AM transceiver base station. An external coil (L), and capacitor (C) are connected as a parallel resonant circuit, that determines the carrier frequency and the oscillator frequency of the reader. This eliminates zero modulation effects by perfect antenna tuning, and avoids the need for an external oscillator.

The reader IC can easily be switched to power down by setting the antenna amplitude to zero.

The MLX90109 can be configured to decode the transponder signal on-chip. In this case the decoded signal is available through a 2-wire interface with clock and data. For minimum interface wiring, the non-decoded transponder signal can also be made available on a single wire interface.

## Contents

Features and Benefits.....	1
Applications Examples.....	1
Ordering Code.....	1
1. Functional diagram.....	2
2. Description.....	2
3. Maximum ratings.....	5
4. Pad definitions and descriptions.....	5
5. MLX90109 Electrical Specifications.....	6
6. Block Diagram.....	7
7. General Description.....	7
7.1. Loop Gain Oscillator.....	7
7.2. Peak Detector.....	7
7.3. Band-Pass Filter.....	7
7.4. Digital demodulator.....	8
7.5. Antenna voltage definition.....	8
7.6. Power Down mode.....	8
7.7. Write operation.....	8
8. System design parameters.....	9
8.1. Auto start-up condition.....	9
8.2. Antenna current.....	9
8.3. Antenna Impedance.....	10
9. Typical configuration: READ ONLY.....	11
9.1. Application diagram.....	11
9.2. Absolute minimum schematic.....	11
9.3. Power consumption.....	11
9.4. Noise cancellation.....	12
9.5. Integrated decoding.....	12
9.6. Close coupling.....	12
10. Typical configuration: READ/WRITE ON/OFF keying (FDX-B100).....	13
10.1. Application diagram.....	13
11. Standard information regarding manufacturability of Melexis products with different soldering processes.....	14
12. ESD Precautions.....	14

<b>13. FAQ</b> .....	<b>15</b>
13.1. Is it possible to make proportional modulation (depth less than 100%) with the MLX90109? .	15
13.2. How should I read data information from a transponder up to 15cm? .....	15
13.3. Is it possible to increase the output power of the MLX90109 transceiver? .....	15
13.4. Are there any specific coils available for the MLX90109 transceiver? .....	15
13.5. What are the recommended pull-up values on DATA and CLOCK pins? .....	15
<b>14. Package Information</b> .....	<b>16</b>
14.1. Plastic SO8 .....	16
<b>15. Contact</b> .....	<b>17</b>
<b>16. Disclaimer</b> .....	<b>17</b>

### 3. Maximum ratings

	Symbol	Condition	Min	Max	Unit
Supply voltage ( $V_{DD}$ with respect to $V_{SS}$ )	$V_{DD}$	DC	-0.3	6	Volts
Input voltage on any pin (except COIL, DATA and CLOCK)	$V_{IN}$		-0.3	$V_{DD}+0.3$	Volts
Input voltage on COIL, DATA and CLOCK	$V_{clamp}$		-0.3	15	Volts
Maximum junction temperature	$T_J$			150	°C

*Table 1: Absolute maximum ratings*

Exceeding the absolute maximum ratings may cause permanent damage. Exposure to absolute-maximum-rated conditions for extended periods may affect device reliability.

### 4. Pad definitions and descriptions

Pad Name	Function
COIL	Oscillator output
$V_{SS}$	Ground
SPEED	Data rate selection : 2kbaud or 4kbaud
MODU	Input for amplitude setting
MODE	Decoding mode selection : Biphase or Manchester
CLOCK	Clock output of decoder
DATA	Data output of decoder
$V_{DD}$	Power Supply

*Table 2: Pin description MLX90109*

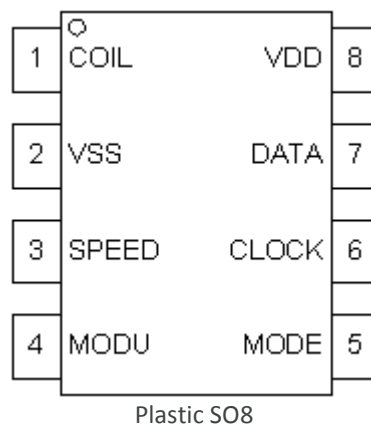

## 5. MLX90109 Electrical Specifications

DC Operating Parameters  $T_A = -40^{\circ}\text{C}$  to  $85^{\circ}\text{C}$ ,  $F_{\text{res}} = 125\text{kHz}$ ,  $V_{\text{DD}} = 3.1$  to  $5.5\text{V}$   
 Antenna parameters:  $L_{\text{ant}} = 73.6\mu\text{H}$ ,  $Q_{\text{ant}} = 17.3$ ,  $Z_{\text{ant}} = 1\text{k}\Omega$

Parameter.	Symbol	Test Conditions	Min	Typ	Max	Units
Supply Voltage	$V_{\text{DD}}$		3.1		5.5	V
Resonance Frequency	$F_{\text{res}}$	(Depends on the resonance frequency of the antenna)	100	125	150	kHz
Frequency drift with temperature	$\Delta F_{\text{res}} (\text{T})$	$F_{\text{res}} = 125 \text{ kHz}$	-1		+1	%
Sensitivity <small>(note 1)</small>	$V_{\text{sens}}$	(Depends on the application)		10	30	mV <sub>pp</sub>
Amplitude Offset <small>(note 2)</small>	$V_{\text{os}}$		0	0.15	0.35	V
Power down voltage (on MODU pin)	$V_{\text{pd}}$	$V_{\text{DD}}=5\text{V}$ $V_{\text{DD}}=3.1\text{V}$	4.0 2.2		4.9 3.0	V
Power up voltage (on MODU pin)	$V_{\text{pu}}$	$V_{\text{DD}}=5\text{V}$ $V_{\text{DD}}=3.1\text{V}$	3.2 1.3		4.3 2.4	V
Power down Current	$I_{\text{DD,pn}}$	$V_{\text{MODU}} = V_{\text{DD}}$	0		1.5	$\mu\text{A}$
Supply Current (excluding antenna supply current) <small>(note 3)</small>	$I_{\text{DD}}$	$V_{\text{DD}}=5\text{V}$ , $V_{\text{MODU}} = 0.8\text{V}$		1.8	3.0	mA
Antenna supply current <small>(note 4)</small>	$I_{\text{DD,ant}}$	(Depends on the application)		2.8		mA
Leakage current on pins COIL, MODE, SPEED, MODE, DATA	$I_{\text{leak}}$	(Power down)			1.0	$\mu\text{A}$
Output voltage DATA and CLOCK pin	$V_{\text{ol}}$	Pull-up resistance $R_{\text{pu}} > 2\text{k}\Omega$			0.4	V

Table 3: Electrical specifications

**Note 1:** The sensitivity is defined as the minimum amplitude of the 2kHz- modulation, generated by the transponder, demodulated and decoded by the reader. This parameter depends on the application:

- the value of  $V_{\text{DD}}$
- the antenna
- the code sent to the reader

**Note 2:** The antenna amplitude voltage is:

$$V_{\text{ant}} = V_{\text{DD}} - V_{\text{MODU}} + V_{\text{os}}$$

**Note 3:** The supply current of the device depends on the antenna drive current  $I_{\text{DD,ant}}$ :

$$\text{Typically: } I_{\text{DD}} \approx 1.3 \text{ mA} + I_{\text{DD,ant}} / 6.3$$

**Note 4:** The antenna supply current (called  $I_{\text{DD,ant}}$ ) is the equivalent DC supply current driven by the chip through the antenna.

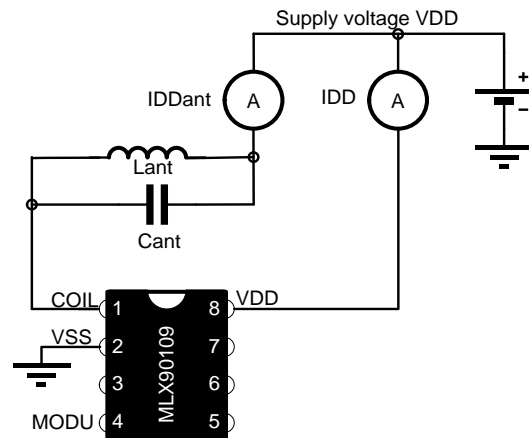

## 6. Block Diagram

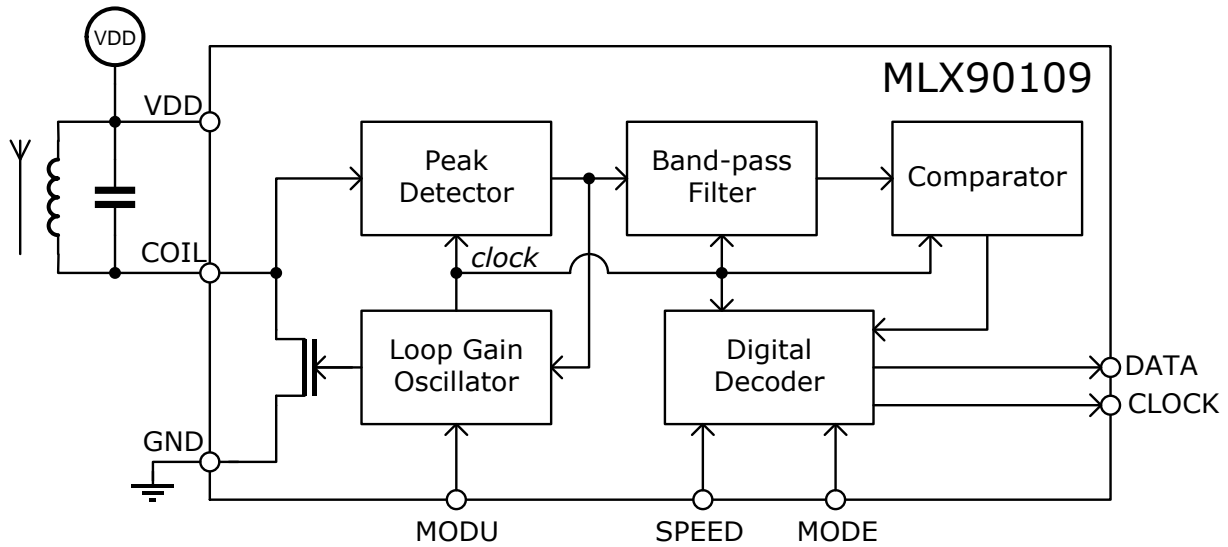

## 7. General Description

### 7.1. Loop Gain Oscillator

The oscillator frequency is locked on the antenna resonance frequency. The clock is derived from the oscillator. In this way, its characteristics are locked to the transmission frequency. As the antenna is used to determine the carrier frequency, the antenna is always perfectly tuned to resonance. Consequently the MLX90109 is not sensitive to zero modulation (the so-called “zero modulation” is the phenomena whereby the tag does modulate properly, but no amplitude modulation can be observed at the reader coil).

### 7.2. Peak Detector

The peak detector of the transceiver detects the AM signal generated by the tag. This signal is filtered and amplified by an on-chip switched capacitor filter before feeding the digital decoder. The same signal is fed back to close the loop of the antenna voltage.

### 7.3. Band-Pass Filter

By setting the SPEED pin to  $V_{DD}$  or to GND, the filtering characteristics are optimized for either 2 or 4 kbaud. The MLX90109 makes an internal first-order filtering of the envelope that changes according to the setting of the SPEED pin, to fit the Biphase and Manchester data spectrum:

2kbaud (speed pin to $V_{DD}$ ):	400Hz to 3.6kHz
4kbaud (speed pin to $V_{SS}$ ):	800Hz to 7.2kHz

## 7.4. Digital demodulator

The MODE pin allows to define whether the MLX90109 will issue directly the filtered data stream on the DATA pin (MODE floating), or decode it in Manchester (MODE = V<sub>DD</sub>) or Biphase (MODE = V<sub>SS</sub>). In these two decoding modes, the MLX90109 issues the tag data on the DATA pin at the rising edge of the clock, which is issued on the CLOCK pin. Both CLOCK and DATA are open drain outputs and require external pull-up resistors.

	V <sub>SS</sub>	FLOAT (*)	V <sub>DD</sub>
<b>SPEED</b>	4kBaud	-	2kBaud
<b>MODE</b>	Biphase	No decoding	Manchester

(\*) Internally strapped to V<sub>DD</sub>/2

## 7.5. Antenna voltage definition

The MLX90109 is a reader IC working in a frequency range of 100 to 150kHz, and designed for use with a parallel L-C antenna. This concept requires significantly less current than traditional serial antennas, for building up the same magnetic field strength.

The voltage on the MODU pin (V<sub>MODU</sub>) controls the amplitude of the antenna voltage V<sub>ant</sub>, as follows:

$$(1) \quad V_{ant} = V_{DD} - V_{MODU} + V_{OS}$$

with V<sub>OS</sub>, the offset relative to the V<sub>MODU</sub> level.

Note: In order to use the internal driver FET as an ideal current source, the voltage on the coil pin should remain higher than its saturation voltage (typically 0.5V) for a driver current (I<sub>driver</sub>) up to 14mA. As this offset can be as much as 300mV, V<sub>MODU</sub> should be higher than 0.8V for a correct operation.

## 7.6. Power Down mode

By setting V<sub>MODU</sub> higher than V<sub>pd</sub> (preferably to V<sub>DD</sub>) the MLX90109 goes in power down. The antenna voltage will fade to 0V. The MLX90109 powers up by pulling V<sub>MODU</sub> below V<sub>pu</sub>.

## 7.7. Write operation

A sequence of power up / power down periods sets the antenna voltage ON and OFF. This feature allows to simply make an ON/OFF-keying modulated signal to the transponder.

Typically, V<sub>MODU</sub> is toggled between V<sub>DD</sub> and 0.8V. Antenna fade-out is related to the quality factor of the antenna (Q<sub>ant</sub>) and its start-up takes about 3 carrier periods.

Refer to the section “Typical operating configurations” further in this document for more detailed information and practical hints.



## 8. System design parameters

The antenna internal driver is switched on as soon as the antenna voltage  $V(\text{COIL})$  drops below  $V_{DD}$  (see graphical representation below). The MLX90109 will inject a current  $I_{\text{driver}}$  into the antenna to make its amplitude follow the voltage on the MODU pin.

In order to make the antenna start swinging on the resonance frequency, the chip needs to provide a positive feedback loop. This loop requires a minimal voltage swing at the COIL pin in order to be operational (typically 100mVpp). Below this value, the MLX90109 may not be able to retrieve its clock.

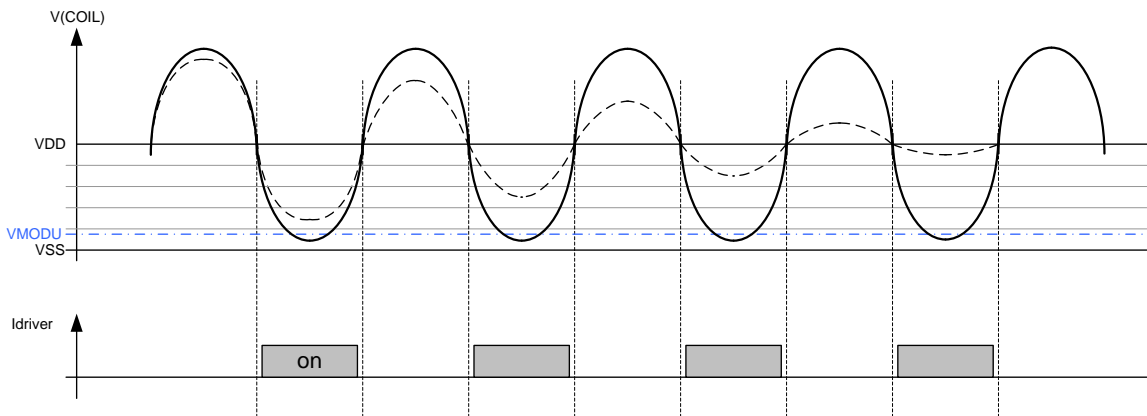

Graph:

Antenna voltage and Driver current during normal operation.  $V_{\text{MODU}}=0.8\text{V}$  for  $V_{DD}=5\text{V}$ . The dashed curve shows the antenna voltage when the reader has been powered down. The internal driver current is a square wave with a 45% duty cycle.

### 8.1. Auto start-up condition

Pulling  $V_{\text{MODU}}$ , at power on, from 5V to less than  $V_{\text{pu}}$  will set the internal driver FET on. Provided the voltage drop on the coil pin is large enough (as explained above), the feedback loop is closed and the oscillation will increase in amplitude.

To obtain the required positive feedback to start-up the oscillation successfully, the antenna impedance  $Z_{\text{ant}}$  should be larger than  $1\text{k}\Omega$ . This is so called “auto start-up condition”.

### 8.2. Antenna current

The MLX90109 is specified to drive a maximum 14mA antenna drive current ( $I_{\text{driver}}$ ).

The AC equivalent supply current ( $I_{DD\text{ant}}$ ) can be calculated as:

$$(2) \quad I_{DD\text{ant}} = \frac{2}{\pi} \cdot \sin(\pi \cdot \alpha) \cdot I_{\text{driver}} = 0.63 \cdot I_{\text{driver}} \quad \text{with } \alpha \text{ the duty cycle which is typically 45\%.$$

The current that the MLX90109 can inject at each oscillation onto the total antenna current is therefore limited to 9mA.

The actual antenna current that generates the magnetic field can be calculated as:

$$(3) \quad I_{\text{ant}} = Q_{\text{ant}} \cdot I_{DD\text{ant}}$$

A typical coil quality factor ( $Q_{\text{ant}}$ ) value is 23, resulting in antenna currents of about 100mA

This current resonance of the parallel antenna allows to build very low power reader base stations, contrary to serial antenna based versions. Readers using a serial antenna can leverage their voltage resonance to drive bigger antenna's for long distance reading up to 1m, whereas the MLX90109 is designed to drive antennas to obtain a reading distance of 1cm up to 15cm (6") (depending on efficiency and dimensions).

### 8.3. Antenna Impedance

The antenna impedance is an important system design parameter for the MLX90109.

$$(4) \quad Z_{ant} = \frac{V_{ant}}{I_{DDant}}$$

The antenna impedance can also be calculated as:

$$(5) \quad Z_{ant} = Q_{ant} \cdot \omega_{res} \cdot L_{ant} \quad \text{with} \quad \omega_{res} = 2\pi \cdot F_{res}$$

From (4) and (5):

$$Q_{ant} \cdot \omega_{res} \cdot L_{ant} = \frac{V_{ant}}{I_{DDant}} \quad \Rightarrow \quad Q_{ant} \cdot I_{DDant} = \frac{V_{ant}}{\omega_{res} \cdot L_{ant}}$$

Finally in comparison with the formula (2):

$$(6) \quad I_{ant} = \frac{V_{ant}}{\omega_{res} \cdot L_{ant}}$$

From the formula above, it is clear that  $Q_{ant}$  has no influence on  $I_{ant}$ . Increasing  $Q_{ant}$  is equivalent to reduce the antenna supply current  $I_{DDant}$ , hence it reduces the overall current consumption.

Using the previous formula (6), it is possible to define the proportionality between the total number of ampere-turns, generating the magnetic field and the inductance of the antenna (With  $N_{ant}$  the number of turns of the antenna coil) :

$$N_{ant} \cdot I_{ant} = N_{ant} \cdot \frac{V_{ant}}{\omega_{res} \cdot L_{ant}} \quad \text{with} \quad L_{ant} \sim N_{ant}^2$$

$$(7) \quad N_{ant} \cdot I_{ant} \sim \frac{1}{\sqrt{L_{ant}}}$$

Hence, to generate a strong field, it is better to choose a low antenna inductance. Limitation to this is given by the minimal antenna impedance ( $Z_{ant} > 1k\Omega$ ) and the Q that one can achieve for such an antenna:

$$(8) \quad L_{min} = \frac{Z_{min}}{Q_{ant} \cdot \omega_{res}}$$

#### Remarks:

Note for equation (4): Mind that in reality the strong coupling with the tag may drastically reduce the antenna impedance.

Note for equation (5): Mind that the quality factor of the antenna ( $Q_{ant}$ ) result in the quality factor of the coil and the quality factor of the capacitance as:

$$(9) \quad Q_{ant} = Q_{coil} // Q_{capacitance}$$

So, a capacitance with a low quality factor may also reduce the antenna impedance.

## 9. Typical configuration: READ ONLY

### 9.1. Application diagram

The MLX90109 is a highly integrated reader IC. In the application schematic below, only two resistors to set  $V_{MODU}$  are required, next to the antenna inductance and tune capacitor. Capacitors  $C_1$  and  $C_D$  can be added for a better noise cancellation.

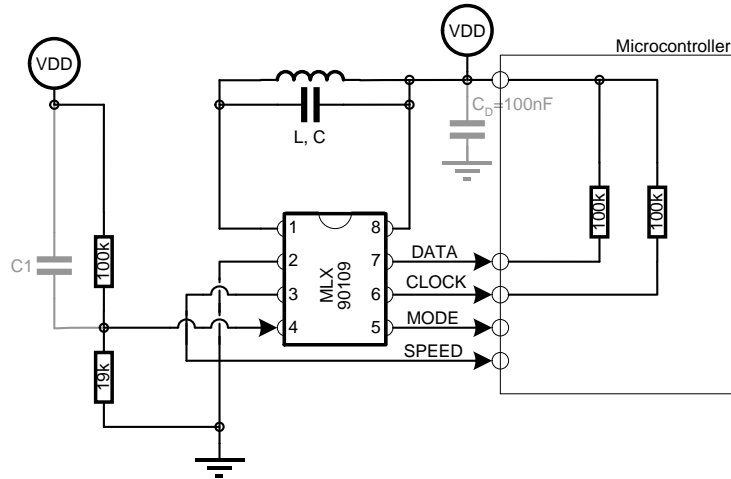

### 9.2. Absolute minimum schematic

The interface with the microcontroller can be realized with only one connection. In this case, the mode pin is left floating and the integrated decoding is not used.

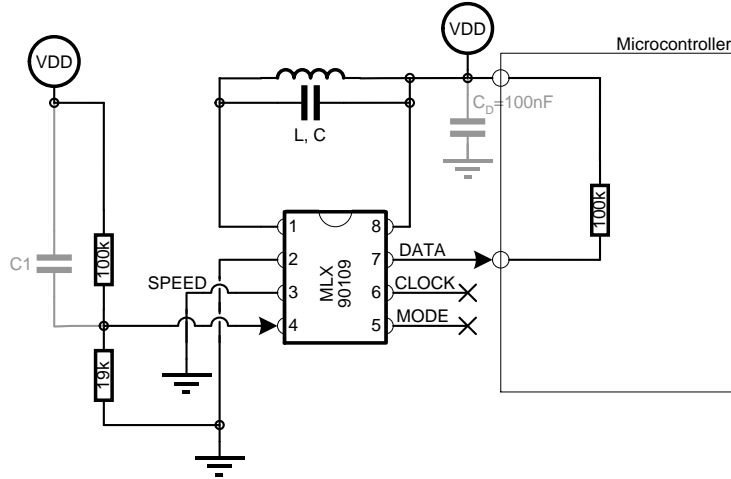

### 9.3. Power consumption

If the power consumption is not critical and the reader does not have to be put in power down, the MODU voltage can be strapped to the required level (between 0.8V and  $V_{pd}$ ). However, the power consumption can be reduced by controlling the voltage on  $V_{MODU}$  pin (e.g. with an IO port of a microcontroller).

## 9.4. Noise cancellation

The read performance of a reader is linked with its robustness versus noise. The IC design has been optimized to get a high signal-to-noise ratio (SNR). The resonant antenna is a natural band-pass filter, which becomes more effective as its quality factor  $Q_r$  increases.

Noise rejection could also be improved by a careful PCB design, and by adding decoupling capacitor(s) on the supply lines. The most sensitive pins to noise injection are MODU and  $V_{DD}$ . Since they directly determine  $V_{ant}$ , the noise could be considered as an amplitude modulation (AM) data from a transponder.

If the noise on both pins were identical, it would cancel out, giving a very noise-insensitive reader. Adding a capacitor  $C_1$  between MODU and  $V_{DD}$ , together with  $R_1$  and  $R_2$  yields a high pass filter with a cut-off frequency at:

$$F_{cut-off} = \frac{1}{2 \cdot \pi \cdot (R_1 // R_2) \cdot C_1}$$

Typically, such a filter should short all noise in the data spectrum, but for many cases, it might be beneficial to set it to less than the net frequencies (50Hz, 60Hz). For example:  $R_1=100k\Omega$ ,  $R_2=19k\Omega$  (to set  $V_{MODU}$ ), and  $C_1=220nF$  gives a cut off frequency of 45Hz.

## 9.5. Integrated decoding

The MLX90109 provides the option to have a decoded output. This significantly reduces the complexity of the microcontroller software.

The data is available when the output clock signal is high. The clock signal has a 50% duty cycle when the data is valid. When the noise level is stronger than the signal level, for instance when no tag is present in the reader field, the duty cycle will be random. The microcontroller can use this feature to detect the presence of a tag: in that case, it must allow some asymmetry on the clock. As the sampling error may be  $4\mu s$ , it should allow a margin of 8 or  $12\mu s$ .

Remark that when the MLX90109 picks up a Manchester-encoded signal whereas the MODE pin is strapped to  $V_{SS}$  (= Biphase decoding), the clock will also be asymmetric.

## 9.6. Close coupling

For very short operating distances, a strong coupling with a tag may drastically reduce the antenna impedance  $Z_{ant}$ . If the current ( $I_{driver}$ ) driven by the antenna internal driver FET goes higher than 14mA, the antenna voltage  $V_{ant}$  may be reduced and the MLX90109 may be unable to read the transponder.

Coupling effect is application-dependent and must be evaluated case by case.

## 10. Typical configuration: READ/WRITE ON/OFF keying (FDX-B100)

### 10.1. Application diagram

The basic principle is to switch the voltage on MODU between 0V and  $V_{DD}$ . The antenna will reach its maximum amplitude in less than 3 periods when MODU is stepped down from  $V_{DD}$  to  $V_{SS}$ . Setting the chip in power-down (set  $V_{MODU}$  up to  $V_{DD}$ ) will let the antenna fade-out with a time constant, depending on the antenna's quality factor  $Q_{ant}$ . For fast protocols, an additional drain resistor on MODU controlled by the microcontroller could be used to decrease the fall time (refer to the application note MLX90109 "100% modulation (ON/OFF Keying)").

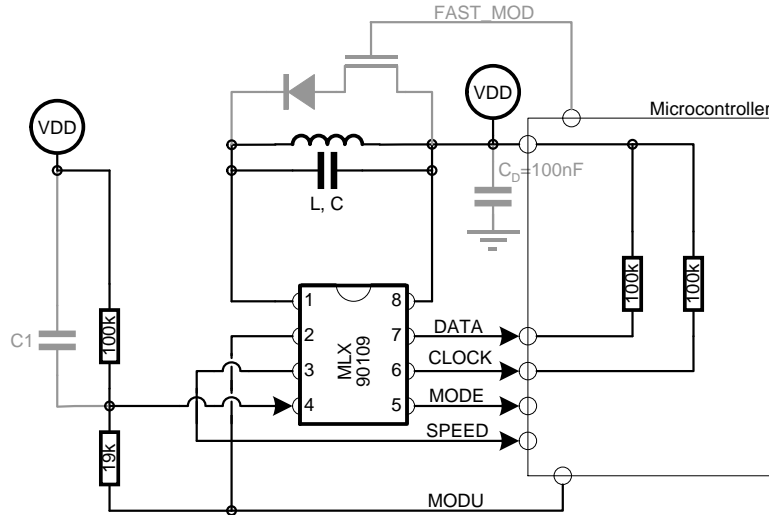

Note : Care should be taken to the capacitor C1 which may reduce the fall time.

## 11. Standard information regarding manufacturability of Melexis products with different soldering processes

Our products are classified and qualified regarding soldering technology, solderability and moisture sensitivity level according to following test methods:

### Reflow Soldering SMD's (Surface Mount Devices)

- IPC/JEDEC J-STD-020  
Moisture/Reflow Sensitivity Classification for Nonhermetic Solid State Surface Mount Devices (classification reflow profiles according to table 5-2)
- EIA/JEDEC JESD22-A113  
Preconditioning of Nonhermetic Surface Mount Devices Prior to Reliability Testing (reflow profiles according to table 2)

### Wave Soldering SMD's (Surface Mount Devices) and THD's (Through Hole Devices)

- EN60749-20  
Resistance of plastic- encapsulated SMD's to combined effect of moisture and soldering heat
- EIA/JEDEC JESD22-B106 and EN60749-15  
Resistance to soldering temperature for through-hole mounted devices

### Iron Soldering THD's (Through Hole Devices)

- EN60749-15  
Resistance to soldering temperature for through-hole mounted devices

### Solderability SMD's (Surface Mount Devices) and THD's (Through Hole Devices)

- EIA/JEDEC JESD22-B102 and EN60749-21  
Solderability

For all soldering technologies deviating from above mentioned standard conditions (regarding peak temperature, temperature gradient, temperature profile etc) additional classification and qualification tests have to be agreed upon with Melexis.

The application of Wave Soldering for SMD's is allowed only after consulting Melexis regarding assurance of adhesive strength between device and board.

Melexis is contributing to global environmental conservation by promoting **lead free** solutions. For more information on qualifications of **RoHS** compliant products (RoHS = European directive on the Restriction Of the use of certain Hazardous Substances) please visit the quality page on our website:

<http://www.melexis.com/quality.aspx>

## 12. ESD Precautions

Electronic semiconductor products are sensitive to Electro Static Discharge (ESD).

Always observe Electro Static Discharge control procedures whenever handling semiconductor products.

## 13. FAQ

### 13.1. Is it possible to make proportional modulation (depth less than 100%) with the MLX90109?

The amplitude of the MLX90109 antenna can be adjusted on the fly by changing the MODU pin level between  $V_{MODU} = 0.8V$  and  $V_{pd}$ . However, the MLX90109 cannot change instantaneously the voltage on its antenna according to a voltage step on MODU pin, and a transient waveform will appear on the voltage antenna. This particular waveform may disturb the transponder and in the worst case (modulation depth more than 20%) the MLX90109 may stop its oscillation.

Using the MLX90109 with proportional modulation (modulation depth less than 100%) is not recommended and supported by Melexis and must be evaluated case by case.

### 13.2. How should I read data information from a transponder up to 15cm?

The reading distance depends on the complete system composed by the reader and the transponder. A reading distance with the MLX90109 transceiver up to 15cm has been demonstrated with a specific reader's antenna (diameter = 130mm, Inductance = 44 $\mu$ H, Quality factor  $Q_{ant} = 87.2@125kHz$ ) and a transponder with a credit card size antenna (80 x 50mm).

### 13.3. Is it possible to increase the output power of the MLX90109 transceiver?

The current flowing through the antenna ( $I_{ANT}$ ) can be maximized by a careful design, respecting the design specification of the MLX90109 (Auto start-up impedance, the maximum driver current  $I_{DRIVER}$ ).

The voltage on the antenna cannot be increased as it is limited by the power supply  $V_{DD}$  ( $V_{ant} \leq V_{DD} - V_{MODU} + V_{os}$ ). Moreover, as the MLX90109 uses the same connection (COIL) for the transmission and the reception, it is not possible to use an external power transistor supplied with a higher voltage than  $V_{DD}$ .

### 13.4. Are there any specific coils available for the MLX90109 transceiver?

Melexis has developed an 18mm coil which is used on the evaluation board EVB90109. Please contact your sales channel if you wish to purchase production quantities.

### 13.5. What are the recommended pull-up values on DATA and CLOCK pins?

The DATA and CLOCK are open-drain drivers which require external pull-up resistors. The values are not critical therefore, to reduce the general power consumption, we recommend to use high ohmic (100k ohm) pull up resistances.

## 14. Package Information

### 14.1. Plastic SO8

The device is packaged in a 8 pin lead free SO package (ROHS compliant MSL1/260°C).

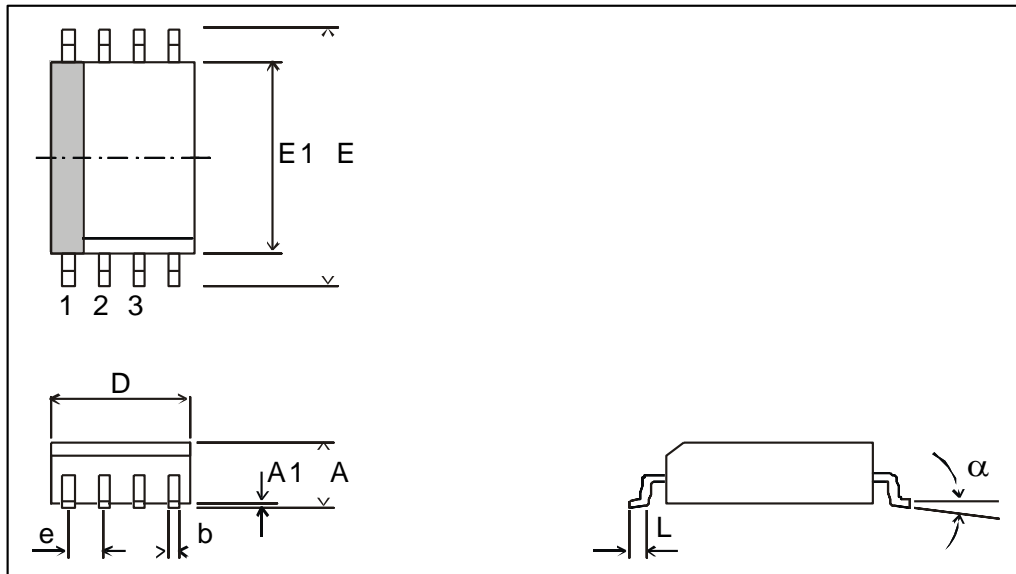

all Dimension in mm, coplanarity < 0.1mm									
	D	E1	E	A	A1	e	b	L	a
min	4.80	3.81	5.80	1.32	0.10	1.27	0.36	0.41	0°
max	4.98	3.99	6.20	1.72	0.25		0.46	1.27	8°
all Dimension in inch, coplanarity < 0.004"									
min	0.189	0.150	0.2284	0.060	0.0040	0.05	0.014	0.016	0°
max	0.196	0.157	0.2440	0.068	0.0098		0.018	0.050	8°



## 15. Contact

For the latest version of this document, go to our website at [www.melexis.com](http://www.melexis.com).

For additional information, please contact our Direct Sales team and get help for your specific needs:

Europe, Africa	Telephone: +32 13 67 04 95
	Email : sales_europe@melexis.com
Americas	Telephone: +1 603 223 2362
	Email : sales_usa@melexis.com
Asia	Email : sales_asia@melexis.com

## 16. Disclaimer

*The information furnished by Melexis herein ("Information") is believed to be correct and accurate. Melexis disclaims (i) any and all liability in connection with or arising out of the furnishing, performance or use of the technical data or use of the product(s) as described herein ("Product") (ii) any and all liability, including without limitation, special, consequential or incidental damages, and (iii) any and all warranties, express, statutory, implied, or by description, including warranties of fitness for particular purpose, non-infringement and merchantability. No obligation or liability shall arise or flow out of Melexis' rendering of technical or other services.*

*The Information is provided "as is" and Melexis reserves the right to change the Information at any time and without notice. Therefore, before placing orders and/or prior to designing the Product into a system, users or any third party should obtain the latest version of the relevant information to verify that the information being relied upon is current. Users or any third party must further determine the suitability of the Product for its application, including the level of reliability required and determine whether it is fit for a particular purpose.*

*The Information is proprietary and/or confidential information of Melexis and the use thereof or anything described by the Information does not grant, explicitly or implicitly, to any party any patent rights, licenses, or any other intellectual property rights.*

*This document as well as the Product(s) may be subject to export control regulations. Please be aware that export might require a prior authorization from competent authorities.*

*The Product(s) are intended for use in normal commercial applications. Unless otherwise agreed upon in writing, the Product(s) are not designed, authorized or warranted to be suitable in applications requiring extended temperature range and/or unusual environmental requirements. High reliability applications, such as medical life-support or life-sustaining equipment are specifically not recommended by Melexis.*

*The Product(s) may not be used for the following applications subject to export control regulations: the development, production, processing, operation, maintenance, storage, recognition or proliferation of 1) chemical, biological or nuclear weapons, or for the development, production, maintenance or storage of missiles for such weapons; 2) civil firearms, including spare parts or ammunition for such arms; 3) defense related products, or other material for military use or for law enforcement; 4) any applications that, alone or in combination with other goods, substances or organisms could cause serious harm to persons or goods and that can be used as a means of violence in an armed conflict or any similar violent situation.*

*The Products sold by Melexis are subject to the terms and conditions as specified in the Terms of Sale, which can be found at <https://www.melexis.com/en/legal/terms-and-conditions>.*

*This document supersedes and replaces all prior information regarding the Product(s) and/or previous versions of this document.*

*Melexis NV © - No part of this document may be reproduced without the prior written consent of Melexis. (2016)*

*ISO/TS 16949 and ISO14001 Certified*

## X-ON Electronics

Largest Supplier of Electrical and Electronic Components

*Click to view similar products for [RFID Transponders](#) category:*

*Click to view products by [Melexis](#) manufacturer:*

Other Similar products are found below :

[PCF7941ATSM2AB120](#), [NT2H0301F0DTL,125](#) [SL2S1512FTBX](#) [AT88SC0808CRF-MX1](#) [HT2DC20S20/F/RSP](#) [V680S-A40 50M](#)  
[NT3H1201W0FTTJ](#) [PN7120A0EV/C10801Y](#) [TRPGP40ATGC](#) [TRPGR30ATGA](#) [M24LR04E-RMC6T2](#) [P5DF081HN/T1AR1070](#)  
[SPS1M003B](#) [SPS1M003A](#) [SPS1M002B](#) [SPS1M002A](#) [V680S-HMD64-ETN](#) [V680S-A40 10M](#) [V680S-A41 10M](#) [V680-D1KP66T](#)  
[PCF7946AT/1081/CM](#) [ATA5577M2330C-DBQ](#) [AS3930-BTST](#) [CLRD710,599](#) [PCF7938XA/CAAB3800](#) [ST25DV64K-JFR6D3](#) [V680S-](#)  
[HMD66-ETN](#) [ST25DV04K-JFR6D3](#) [AT88RF04C-MVA1](#) [ST25DV16K-JFR6D3](#) [NVT4857UKAZ](#) [NT2H1611G0DA8J](#) [LXMSANAA19-181](#)  
[PCF7936AA/3851/C/6](#) [KH-RFID-4216-BQ](#) [KH-RFID-7023-BQ](#) [KH-RFID-8046-BQ](#) [60208](#) [60170](#) [PN7150B0HN/C11006Y](#)  
[PN7150B0HN/C11006E](#) [RF-HDT-DVBB-N2](#) [SRTAG2K-DMC6T/2](#) [TRPGR30ATGB](#) [PN5120A0HN1/C2,157](#) [RF37S114HTFJB](#)  
[MF3MOD4101DA4/05,1](#) [MAX1473EUI+T](#) [NRF51822-QFAA-R](#) [28340](#)