

1. Features and Benefits

- 1-chip solution (Hall element + Output Drivers)
- Soft Switching for low noise
- Two-Stage Thermal Protection
- Locked Rotor Protection and auto-restart
- FG and RD available in 4-pin VK (“No-VDD” design)
- Pin-to-pin compatible with US90A & US91A

2. Applications

- 12V and 24V Two-Coil motors with high mutual inductance (2-wire parallel winding method).

3. Ordering information

Product Code	Temperature Code	Package Code	Option Code	Packing Form Code
MLX90285	L	VK	ABA-000	BU
MLX90285	L	VK	AAA-000	BU
MLX90285	L	DC	ABA-000	RE
MLX90285	L	DC	AAA-000	RE

Legend:

Temperature Code: L for Temperature Range -40°C to 150°C
 Package Code: VK for Plastic Single in Line ,
 DC for SOIC8 (AECQ100 compliant)
 Option Code: AAA-000 for Frequency Generation (FG),
 ABA-000 for Rotation Detection (RD)
 Packing Form: BU for Bulk, RE for Reel (live bug)
Ordering example: MLX90285LVK-ABA-000-BU

4. Functional Diagram

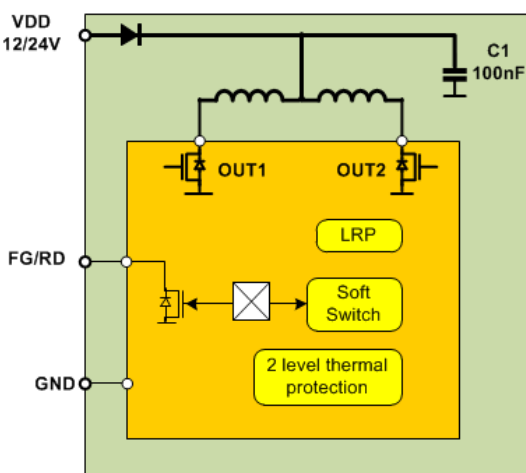

5. General Description

The MLX90285 is a one-chip solution for driving two-coil brushless DC cooling fans. The device features Soft Switching to lower acoustic and electrical fan noise. This efficient solution is enhanced with an intelligent Active Slope Control which automatically adjusts the slope duration depending on the fan rotation speed. Thus, the fan performance to noise ratio is always kept optimum without the need of tuning via external component. The device includes a novel Two-Stage Thermal Protection as well as Locked Rotor Protection for demanding application safety requirements. Frequency Generator or Rotation Detection is available. The open-drain output makes the connectivity with any external interface for hardware monitoring easier. These features are combined with the Melexis patented no-VDD design to fit the IC in small 4-pin VK package. The device is also delivered in DC package for automatic assembly.

Contents

1. Features and Benefits	1
2. Applications	1
3. Ordering information.....	1
4. Functional Diagram.....	1
5. General Description	1
6. Glossary of Terms	4
7. Absolute Maximum Ratings	4
8. Application Information	4
9. General Electrical Specifications	5
10. Magnetic Specifications	6
11. Driver Output vs Magnetic Pole	6
12. Detailed General Description	6
13. Unique Features	7
13.1. Active Soft Switching.....	7
13.2. Best Performance to Noise compromise	8
13.3. Two-Stage Thermal protection.....	8
14. Performance Graphs.....	9
14.1. $R_{DS(on)}$ vs. T_J	9
14.2. $R_{DS(on)}$ vs. V_{DD}	9
14.3. Magnetic parameters vs. T_J	9
14.4. Magnetic parameters vs. V_{DD}	9
14.5. I_{DD} vs. T_J	9
14.6. I_{DD} vs. V_{DD}	9
14.7. V_{OL} vs T_J	10
14.8. Power dissipation vs. T_A	10
15. Standard information regarding manufacturability of Melexis products with different soldering processes.....	Error! Bookmark not defined.
16. ESD Precautions.....	Error! Bookmark not defined.
17. Packages Information (Outline Drawing, Hall Plate location & Pinout)	12
17.1. VK Package (4-pin TO92).....	12
17.2. DC Package (8-pin narrow SOIC)	13
18. Revision history.....	14

MLX90285

24V Low Noise Two-Coil Fan Driver



19. Contact 14

20. Disclaimer 14

6. Glossary of Terms

Two-coil fan	A fan with two-coil windings where current alternates from 1 coil to the other depending on the direction of the magnetic field.
MilliTesla (mT), Gauss	Units of magnetic flux density : 1mT = 10 Gauss
V _{DD}	Voltage on the coils common node.
I _{DD}	Current supplying the chip which flows through the coil connected to the switched off output driver.
Peak output current	The current flowing in the coil at start-up, only limited by the coil resistance R _{COIL} and the output driver resistance R _{DSON} .
Continuous output current	The current flowing in the coil when the fan is spinning normally.
Locked rotor	The state when the fan stopped spinning due to mechanical blockage.
LFPM	Linear Feet Per Minute – Unit of airflow velocity

7. Absolute Maximum Ratings

Parameter	Symbol	Value	Units
Fan Supply Voltage (Continuous)	V _{DDcont}	30	V
Fan Supply Voltage (Peak < 100 s)	V _{DDpeak}	60	V
Output Current (Continuous)	I _{OUTcont}	350	mA
Output Current (Peak)	I _{OUTpeak}	700	mA
FG/RD Voltage	V _{FG/RD}	28	V
FG/RD Output Current (sink)	I _{FG/RD}	20	mA
Operating Junction Temperature Range	T _J	-40 to 150	C
Magnetic Flux Density	B	Unlimited	mT

Table 1: Absolute maximum ratings

Exceeding the absolute maximum ratings may cause permanent damage. Exposure to absolute-maximum-rated conditions for extended periods may affect device reliability.

8. Application Information

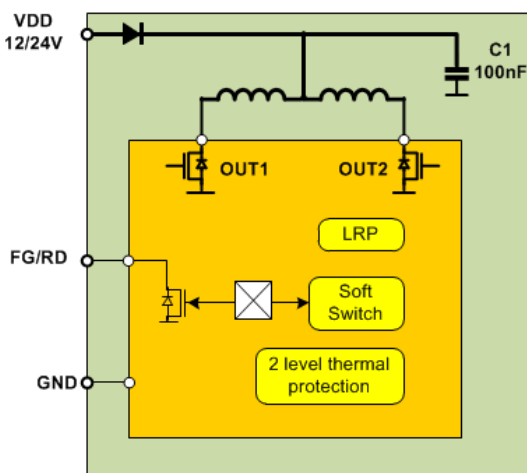

Typical two-coil fan application circuit

At power-on, the FG/RD output is kept high for at least 500 μs independently of the rotation status or magnetic field. It prevents appearance of unexpected impulses or oscillation on the FG/RD output signal due to broken coil (i.e. open connection) or short connection between OUT1 or OUT2 to ground.

A decoupling capacitor from 100nF or higher should be placed between the V_{DD} point (fan common node) and IC ground. It reduces the risk of electrical over-stress damage to ground bouncing when plugging/unplugging the fan connector.

Speed control schemes using a transistor on the ground pin are not recommended as it may damage the IC. Please contact your nearest sales contact, if you require speed control.

9. General Electrical Specifications

DC Operating Parameters $T_J = 25^\circ\text{C}$, $V_{DD} = 24\text{V}$ (unless otherwise specified)

Parameter	Symbol	Test Conditions	Min	Typ	Max	Units
Fan Supply Voltage	V_{DD}	Recommended Operating (average)	9.6		30	V
Extended Operating Voltage ⁽²⁾	V_{DD}	Fully Functional	5		30	V
Supply Current	I_{DD}			2	4	mA
Power-On Reset Voltage	V_{POR}			1.8		V
Output Driver Resistance	R_{DSON}			2	3	ohms
		$V_{DD} = 5\text{V}$		3	5	ohms
Output Clamping Voltage	$V_{OUT1,2}$		60		80	V
FG / RD Output Low Voltage	V_{OL}	$I_{OL} = 10\text{mA}$		250	500	mV
FG / RD Output Clamp Voltage	V_{CLAMP}		28			V
FG / RD Output Leakage Current	I_{LEAK}	$V_{FG} (V_{RD}) = 18\text{V}$			10	μA
Typical Rotation Speed Range with Active Slope Control	ASL_{ON}	$V_{DD} = 12$ to 24V 2-pole pair rotor magnet	2300		6700	RPM
Output Slope Duration To Torque Period Ratio ^(3,4)	SL_{RATIO}	$V_{DD} = 12$ to 24V		6.25	10	%
		$V_{DD} = 5\text{V}$		4.2	10	%
Locked Rotor Period	T_{ON}			0.43		sec
Locked Rotor Period	T_{OFF}			2.6		sec
Thermal Protection Level1 ON ⁽⁵⁾	$TSD1_{ON}$			140		C
Thermal Protection Level1 OFF	$TSD1_{OFF}$			120		C
Thermal Protection Level2 ON	$TSD2_{ON}$			160		C
Thermal Protection Level2 OFF	$TSD2_{OFF}$			140		C
DC Thermal Resistance	R_{TH-ja}	One-sided PCB, zero LFPM		150		C/W
	R_{TH-jc}			50		
VK Thermal Resistance	R_{TH-ja}	One-sided PCB, zero LFPM		200		
	R_{TH-jc}			70		

Table 2: General electrical specifications

¹ The minimal value of V_{DD} should be determined using the following equation: $V_{DD} = 9.6\text{V} + R_{COIL} * I_{DD}$

² The extended operating voltage is the range in which the device is able to start-up properly (down to 5V) with full functionality of the device (including basic function like magnetic field sensing, FG output, Locked Rotor protection,...) with potential deviation versus normal operating conditions

³ The SL_{RATIO} is defined as the ratio of the slope duration over the motor torque period, equal to the half of the electrical output period T of $OUT1$ or $OUT2$:

$$SL_{RATIO} = \frac{t_{SLOPE}}{T_M} = \frac{2 \cdot t_{SLOPE}}{T_{OUT}}$$

⁴ Within ASL_{ON} range, slope measured from V_{DSON} to 100% V_{DD}

⁵ Output Slope Duration reduced to half its normal value

10. Magnetic Specifications

DC Operating Parameters $T_J = 25^\circ\text{C}$, $V_{DD} = 5$ to 30V (unless otherwise specified)

Parameter	Symbol	Min	Typ	Max	Units
Operate point	B_{OP}	0.5	3	6	mT
Release point	B_{RP}	-6	-3	-0.5	mT
Hysteresis	B_{HYST}	2	6		mT

Table 3: Magnetic specifications

11. Driver Output vs Magnetic Pole

Parameter	Test Conditions	OUT1	OUT2	FG ⁽⁶⁾
North pole	$B < B_{RP}$ – all packages	High	Low	High
South pole	$B > B_{OP}$ - all packages	Low	High	Low

Table 4: Driver output vs. magnetic pole (7)

12. Detailed General Description

The MLX90285 is a one-chip solution for driving two-coil brushless DC cooling fans.

Based on mixed-signal CMOS design, the device includes Hall-effect sensor with offset cancellation scheme, voltage regulator, digital logic and power output drivers in a single package.

The MLX90285-FG version has an open-drain tachometer FG output that follows the Hall signal. This signal is used by hardware monitoring system to determine the rotation speed of the fan.

In the MLX90285-RD version, the open-drain alarm output RD is a safety signal which allows detecting if the fan rotates or not. It is active low during normal spinning of the motor. It goes high when the magnetic flux switching frequency drops below nearly 1.15Hz (35RPM for 2 pole-pair fan)

The built-in locked rotor protection automatically shuts off the coil current when the rotor is mechanically blocked for more than 0.43 second. The fan tries to restart every 3 seconds until the rotor is released. This on/off cycling reduces the average current by factor of about 7. This protection prevents the fan to be overheated or damaged.

The device is based on the Melexis patented “no-VDD” design which removes the need of separate supply voltage pin for two-coil fan. During operation, the power outputs are always operating as complementary, meaning also that one power output is kept inactive while the other is active. Melexis cleverly turned this fact into benefit as “No-VDD” devices such as MLX90285 recover the power supply through the inactive power output pin. Therefore, a separate supply voltage pin is not required anymore and the device including logical output FG/RD can fit into a small 4-pin through-hole package VK.

In the application, the “No-VDD” design inherently isolates the IC behind the fan coils. Without direct output to the external environment, the device is best protected against ESD and over-voltage issue on the power supply voltage line.

⁶ FG state is only valid during normal operation. In locked rotor protection, FG signal is high

⁷ The magnetic pole is applied facing the branded side of the package

13. Unique Features

13.1. Active Soft Switching

The use of the Melexis Soft Switching techniques in the US168/169 and US651/661 has already proven its efficiency to noticeably reduce electrical and acoustic noise by precisely control the output slope duration on the fan coil. The US168/168 is the first generation with fixed output slope duration and the US651/661 is the second generation with possibility for the user to fine-tune the slope duration via an external pin.

The MLX90285 represents the third generation of soft switching device as it goes even a step further into intelligence and smart driving.

It mainly combines the major advantage of each previous generation:

Adjustable Slope Control → best balance between motor performance and acoustic/electrical noise

No need of external component for slope control → cost efficiency and simplicity

“Adjustable without external component” is possible as the device automatically determine the slope duration depending on the fan rotation speed.

The MLX90285 determines the fan rotation speed by measuring the half output switching period from the magnetic field signal. The output slope duration is extrapolated by measuring the duration from the falling edge on OUT1 to the cross over with OUT2.

The result is processed to determine the actual Output Slope Duration to Torque Period Ratio ($SL_{RATIO} = 2 \cdot t_{SLOPE} / T_{OUT}$), leading to two possible options:

If $SL_{RATIO} < 6.25\%$ (typical), the slope duration should be increased

If $SL_{RATIO} > 6.25\%$ (typical), the slope duration should be decreased

The Digital Slope Duration Control register is incremented or decremented accordingly, thus updating the slope duration value for both outputs OUT1 and OUT2, prior the next rising slope occurring on OUT1.

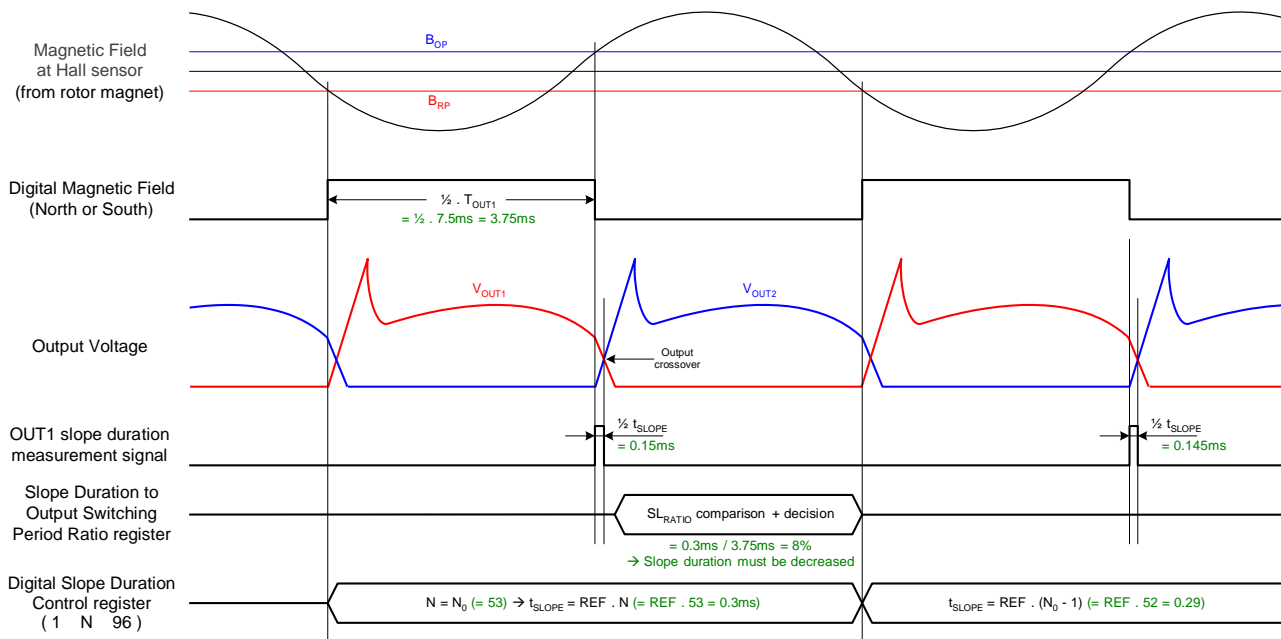

1 - All values in green are arbitrary and just given for example purpose
 2 - Condition example: 4000RPM, 2-pole pair rotor magnet, initial slope duration = 0.3ms, target $SL_{RATIO} = 6.25\%$

Figure 1: Active Soft Switching Operation Principle

The Slope Control provides smooth change in the coil current and allows reducing both electrical and acoustic noise.

In addition, the MLX90285 slope generation is processed upon reaching a precise magnetic threshold B_{OP}/B_{RP} . Unlike other fan driver using the rotor magnetic field amplitude which might lead to difficulty in adequate rotor magnet magnetisation, the Melexis solution provides best results with different fan size with weaker or stronger rotor magnet.

13.2. Best Performance to Noise compromise

The MLX90285 features a typical 6.25% ratio between slope duration over the torque period, proportional to the fan rotation speed. This value is controlled to provide the best compromise between fan performance (rotation speed and current consumption) and acoustic noise. Increasing this ratio mainly lowers the motor efficiency while decreasing this ratio removes the low noise benefit.

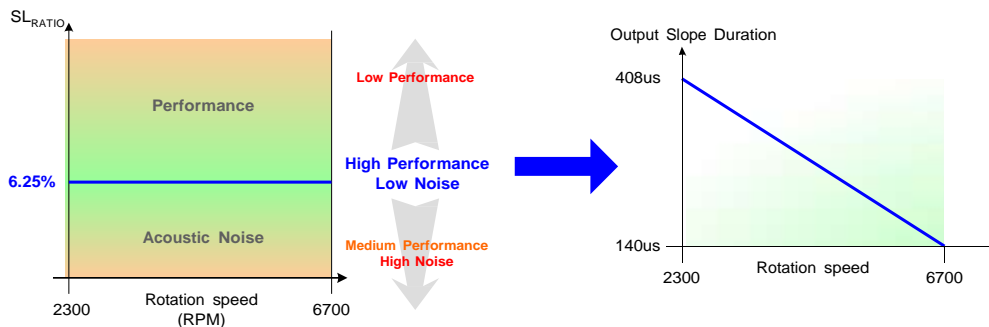

Figure 2: Slope Duration to Torque Period Ratio effect

The device keeps this ratio constant within a large rotation speed range from 2300RPM to 6700RPM (2-pole pair fan). Therefore, the device automatically adjusts its low noise specification to a given cooling application requirements.

13.3. Two-Stage Thermal protection

The use of soft switching through linear slope control leads to an increase of the IC junction temperature. As a result, using long slope and high output current can result in reaching the thermal protection threshold and so shut off the device to prevent overheating. In the application, it would stop a low noise cooling fan in an environment where cooling is a required due to high temperature.

The MLX90285 is the first fan driver to integrate a Two-Stage Thermal Protection.

When the IC junction temperature exceeds a 1st thermal threshold $TSD1_{ON}$ (140°C typical), the slope duration are unconditionally divided to half the actual value. The immediate effect is a reduction of the average power dissipation, hence it stabilizes or even starts reducing the IC junction temperature so the cooling fan continues rotating to provide airflow in a system.

The slope duration is back to normal when the junction temperature decreases below $TSD1_{OFF}$ (120°C typical).

However, in case the reduction of the slope duration is not enough to stop the junction temperature increase, the device has a 2nd thermal threshold $TSD2_{ON}$ (160°C typical) which then shuts-off the IC to prevent over-heating. All the outputs OUT1, OUT2 and FG/RD goes to high level and stay in this state until the junction temperature decreases below $TSD2_{OFF}$ (140°C typical).

14. Performance Graphs

14.1. $R_{DS(ON)}$ vs. T_J

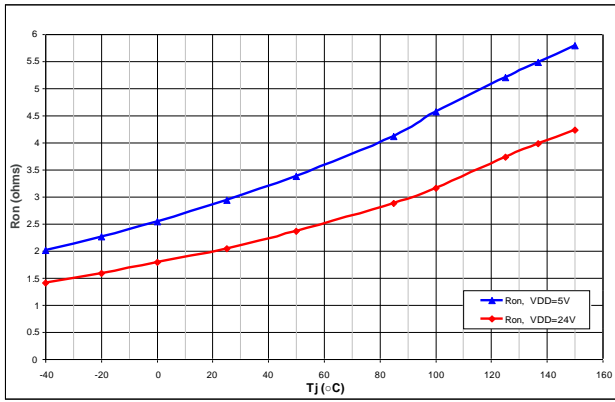

14.2. $R_{DS(ON)}$ vs. V_{DD}

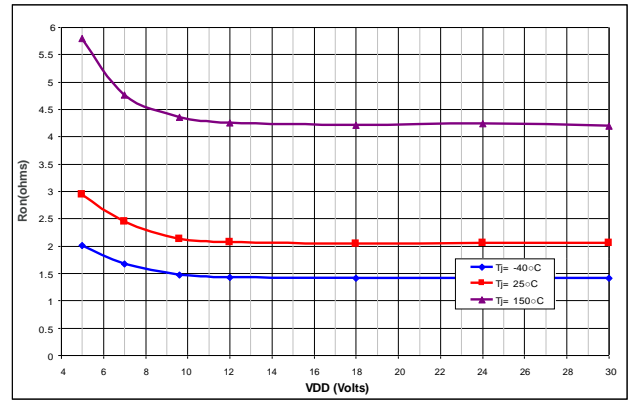

14.3. Magnetic parameters vs. T_J

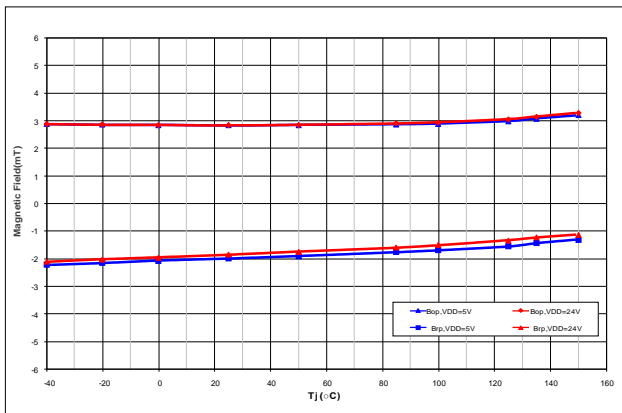

14.4. Magnetic parameters vs. V_{DD}

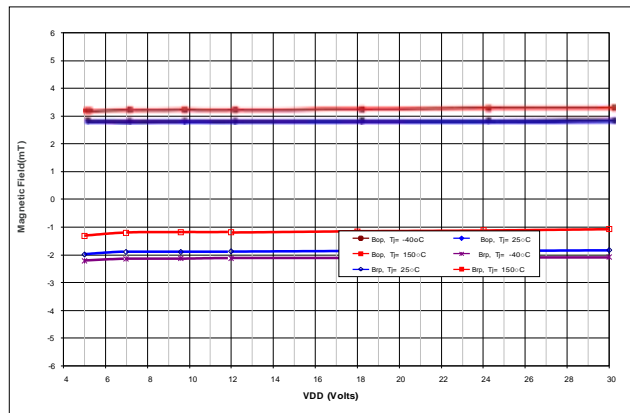

14.5. I_{DD} vs. T_J

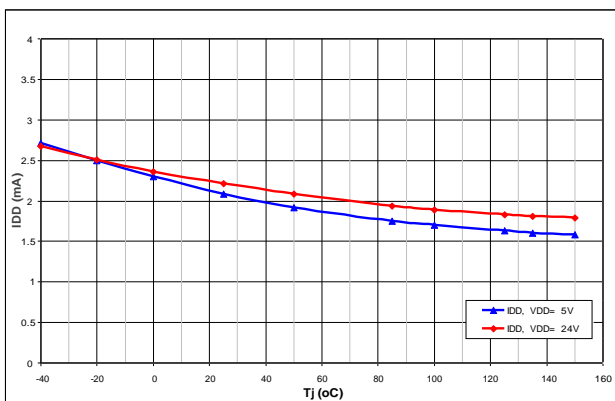

14.6. I_{DD} vs. V_{DD}

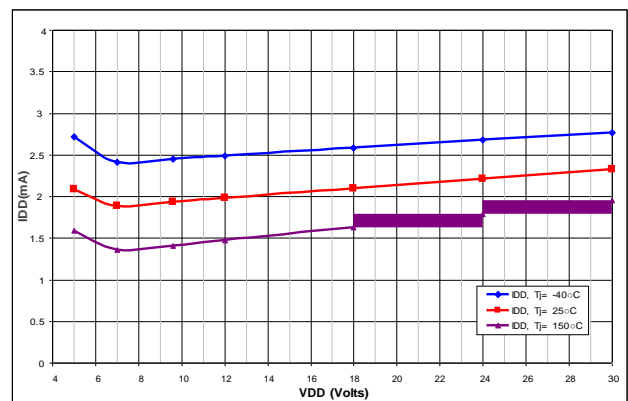

14.7. V_{OL} vs T_J

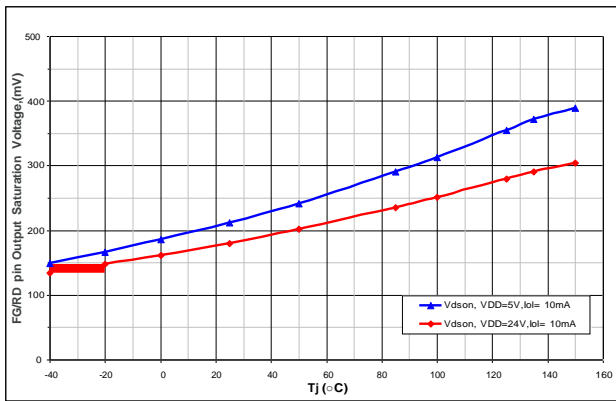

14.8. Power dissipation vs. T_A

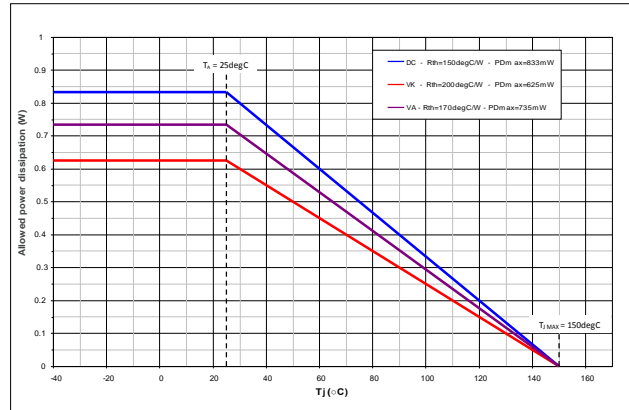

15. Standard information regarding manufacturability of Melexis products with different soldering processes

Our products are classified and qualified regarding soldering technology, solderability and moisture sensitivity level according to following test methods:

Reflow Soldering SMD's (Surface Mount Devices)

- IPC/JEDEC J-STD-020
Moisture/Reflow Sensitivity Classification for Nonhermetic Solid State Surface Mount Devices (classification reflow profiles according to table 5-2)
- EIA/JEDEC JESD22-A113
Preconditioning of Nonhermetic Surface Mount Devices Prior to Reliability Testing (reflow profiles according to table 2)

Wave Soldering SMD's (Surface Mount Devices) and THD's (Through Hole Devices)

- EN60749-20
Resistance of plastic- encapsulated SMD's to combined effect of moisture and soldering heat
- EIA/JEDEC JESD22-B106 and EN60749-15
Resistance to soldering temperature for through-hole mounted devices

Iron Soldering THD's (Through Hole Devices)

- EN60749-15
Resistance to soldering temperature for through-hole mounted devices

Solderability SMD's (Surface Mount Devices) and THD's (Through Hole Devices)

- EIA/JEDEC JESD22-B102 and EN60749-21
Solderability

For all soldering technologies deviating from above mentioned standard conditions (regarding peak temperature, temperature gradient, temperature profile etc) additional classification and qualification tests have to be agreed upon with Melexis.

The application of Wave Soldering for SMD's is allowed only after consulting Melexis regarding assurance of adhesive strength between device and board.

Melexis recommends reviewing on our web site the General Guidelines [soldering recommendation](http://www.melexis.com/Quality_soldering.aspx) (http://www.melexis.com/Quality_soldering.aspx) as well as [trim&form recommendations](http://www.melexis.com/Assets/Trim-and-form-recommendations-5565.aspx) (<http://www.melexis.com/Assets/Trim-and-form-recommendations-5565.aspx>).

Melexis is contributing to global environmental conservation by promoting **lead free** solutions. For more information on qualifications of **RoHS** compliant products (RoHS = European directive on the Restriction Of the use of certain Hazardous Substances) please visit the quality page on our website: <http://www.melexis.com/quality.aspx>

16. ESD Precautions

Electronic semiconductor products are sensitive to Electro Static Discharge (ESD). Always observe Electro Static Discharge control procedures whenever handling semiconductor products.

17. Packages Information (Outline Drawing, Hall Plate location & Pinout)

17.1. VK Package (4-pin TO92)

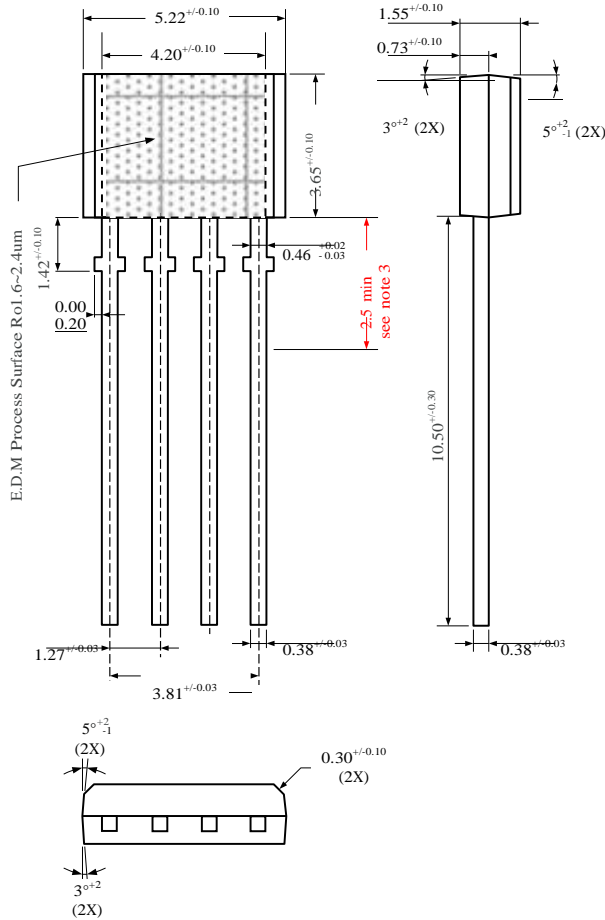

Notes:

1. All dimensions are in millimeters
2. Package dimension exclude molding flash. Mold flash shall not exceed 0.127mm.
3. To preserve reliability, it is recommended to have total lead length equal to 2.5mm minimum, measured from the package line.
4. VK package is a pin through-hole package, hence adapted for wave soldering process. A reflow soldering process is not recommended with VK package as it may seriously affect device reliability.

Marking:

Top side :

1st Line = 285FG (or 285RD) - Part number (MLX90285) and Option Code

2nd Line - xxxyww - xx = Lot number

y = year (last digit)

ww = calendar week

Hall plate location

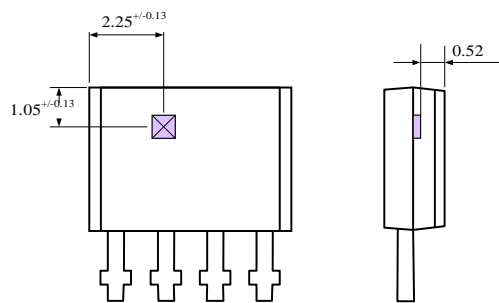

Notes:

1. All dimensions are in millimeters

Pin number (VK)	Pin Name	Function
1	FG (RD)	FG (RD) open drain output signal
2	OUT1	Open Drain Coil Driver 1
3	OUT2	Open Drain Coil Driver 2
4	GND	Ground pin

17.2. DC Package (8-pin narrow SOIC)

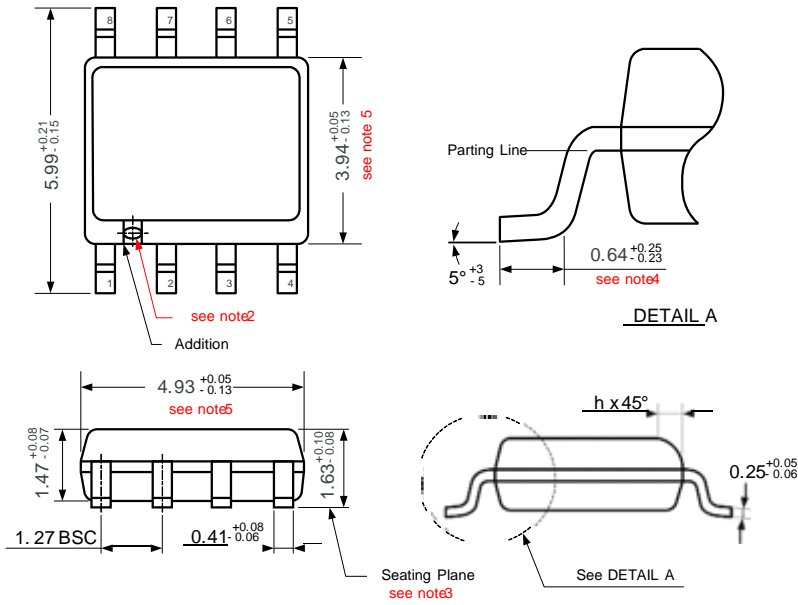

Notes:

- Controlling dimensions in millimeters.
- The appearance of pin 1 is optional, round type on single leadframe and rectangular type on matrix leadframe.
- Formed leads shall be planar with respect to one another within 0.0792mm at seating plane.
- Length of terminal for soldering to a substrate.
- Package length and width are reference datums and do not include mold flash or protrusions, but does include mold mismatch and are measured at the mold parting line.
Mold flash or protrusions shall not exceed 0.1524mm at end and 0.254mm at window.
- This part is compliant with JEDEC standard MS-012.

Marking:

Top side :

1st Line = MLX285 – Part number (MLX90285)
 2nd Line = FGyyww (or RDyyww) – Option Code and Datecode
 yy -year
 ww - calendar week
 3rd Line = xxxxxx – Lot number

Marking on top side is duplicated on bottom side

Hall plate location

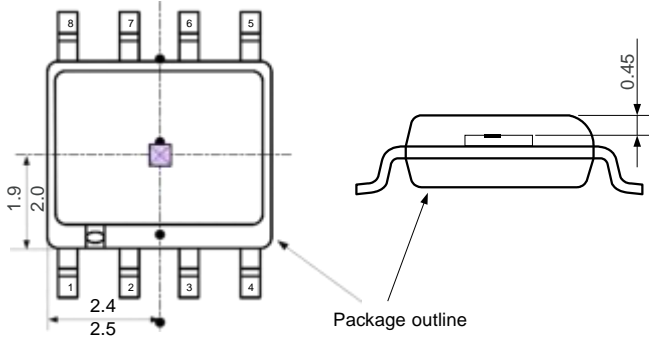

Notes:

- All dimensions are in millimeters.

Pin number (DC)	Pin Name	Function
1	FG (RD)	FG (RD) open drain output
2	OUT1	Open Drain Coil Driver 1
3	GND	Ground pin
4	OUT2	Open Drain Coil Driver 2
5, 6, 7, 8	-	Not Connected

18. Revision history

Rev	Date	Comment
007	6-Jun-17	<ul style="list-style-type: none"> New template Updated solderability guidelines

19. Contact

For the latest version of this document, go to our website at www.melexis.com.

For additional information, please contact our Direct Sales team and get help for your specific needs:

Europe, Africa	Telephone: +32 13 67 04 95
	Email : sales_europe@melexis.com
Americas	Telephone: +1 603 223 2362
	Email : sales_usa@melexis.com
Asia	Email : sales_asia@melexis.com

20. Disclaimer

The information furnished by Melexis herein ("Information") is believed to be correct and accurate. Melexis disclaims (i) any and all liability in connection with or arising out of the furnishing, performance or use of the technical data or use of the product(s) as described herein ("Product") (ii) any and all liability, including without limitation, special, consequential or incidental damages, and (iii) any and all warranties, express, statutory, implied, or by description, including warranties of fitness for particular purpose, non-infringement and merchantability. No obligation or liability shall arise or flow out of Melexis' rendering of technical or other services.

The Information is provided "as is" and Melexis reserves the right to change the Information at any time and without notice. Therefore, before placing orders and/or prior to designing the Product into a system, users or any third party should obtain the latest version of the relevant information to verify that the information being relied upon is current. Users or any third party must further determine the suitability of the Product for its application, including the level of reliability required and determine whether it is fit for a particular purpose.

The Information is proprietary and/or confidential information of Melexis and the use thereof or anything described by the Information does not grant, explicitly or implicitly, to any party any patent rights, licenses, or any other intellectual property rights.

This document as well as the Product(s) may be subject to export control regulations. Please be aware that export might require a prior authorization from competent authorities.

The Product(s) are intended for use in normal commercial applications. Unless otherwise agreed upon in writing, the Product(s) are not designed, authorized or warranted to be suitable in applications requiring extended temperature range and/or unusual environmental requirements. High reliability applications, such as medical life-support or life-sustaining equipment are specifically not recommended by Melexis.

The Product(s) may not be used for the following applications subject to export control regulations: the development, production, processing, operation, maintenance, storage, recognition or proliferation of 1) chemical, biological or nuclear weapons, or for the development, production, maintenance or storage of missiles for such weapons; 2) civil firearms, including spare parts or ammunition for such arms; 3) defense related products, or other material for military use or for law enforcement; 4) any applications that, alone or in combination with other goods, substances or organisms could cause serious harm to persons or goods and that can be used as a means of violence in an armed conflict or any similar violent situation.

The Products sold by Melexis are subject to the terms and conditions as specified in the Terms of Sale, which can be found at <https://www.melexis.com/en/legal/terms-and-conditions>.

This document supersedes and replaces all prior information regarding the Product(s) and/or previous versions of this document.

Melexis NV © - No part of this document may be reproduced without the prior written consent of Melexis. (2016)

ISO/TS 16949 and ISO14001 Certified

X-ON Electronics

Largest Supplier of Electrical and Electronic Components

Click to view similar products for [Motor/Motion/Ignition Controllers & Drivers](#) category:

Click to view products by [Melexis](#) manufacturer:

Other Similar products are found below :

[FSB50550TB2](#) [FSBF15CH60BTH](#) [MSVCPM2-63-12](#) [MSVGW45-14-2](#) [MSVGW54-14-3](#) [MSVGW54-14-5](#) [NTE7043](#) [LA6565VR-TLM-E](#)
[LB11650-E](#) [LB1837M-TLM-E](#) [LB1845DAZ-XE](#) [LC898300XA-MH](#) [SS30-TE-L-E](#) [26700](#) [LV8281VR-TLM-H](#) [BA5839FP-E2](#) [IRAM236-1067A](#) [LA6584JA-AH](#) [LB11847L-E](#) [NCV70501DW002R2G](#) [AH293-PL-B](#) [TND315S-TL-2H](#) [FNA23060](#) [FSB50250AB](#) [FNA41060](#)
[MSVB54](#) [MSVBTC50E](#) [MSVCPM3-54-12](#) [MSVCPM3-63-12](#) [MSVCPM4-63-12](#) [MSVTA120](#) [FSB50550AB](#) [NCV70501DW002G](#)
[LC898301XA-MH](#) [LV8413GP-TE-L-E](#) [MSVGW45-14-3](#) [MSVGW45-14-4](#) [MSVGW45-14-5](#) [MSVGW54-14-4](#) [STK984-091A-E](#)
[SLA7026M](#) [MP6519GQ-Z](#) [LB11651-E](#) [IRSM515-025DA4](#) [LV8127T-TLM-H](#) [MC33812EKR2](#) [NCP81382MNTXG](#) [TDA21801](#)
[LB11851FA-BH](#) [NCV70627DQ001R2G](#)