

MLX90314

Programmable Sensor Interface

1. Features and Benefits

- Microprocessor-controlled signal conditioning for bridge-type sensors
- Suited for low-cost sensors: reduction of non-linearity by programmable coefficients
- External or internal temperature sensor for compensating temperature errors
- Versatile output signal ranges: 4, 5, 10, or 11VDC; 4 to 20 mA loop
- Mass calibration easy with 2400 or 9600 baud UART
- Power supply from 6 to 35VDC

2. Application Examples

- Pressure transducers
- Accelerometers
- Temperature sensor assemblies
- Linear position sensors

3. Ordering information

Product Code	Temperature Code	Package Code	Option Code	Packing Form Code
MLX90314	L	DF	BBA-000	TU
MLX90314	L	DF	BBA-000	RE

Legend:

Temperature Code: L for Temperature Range -40°C to 150°C

Package Code: DF for SOIC300Mil

Packing Form: RE for Reel, TU for Tube

Ordering example: MLX90314LDF-BAA-000-TU

4. Functional Diagram

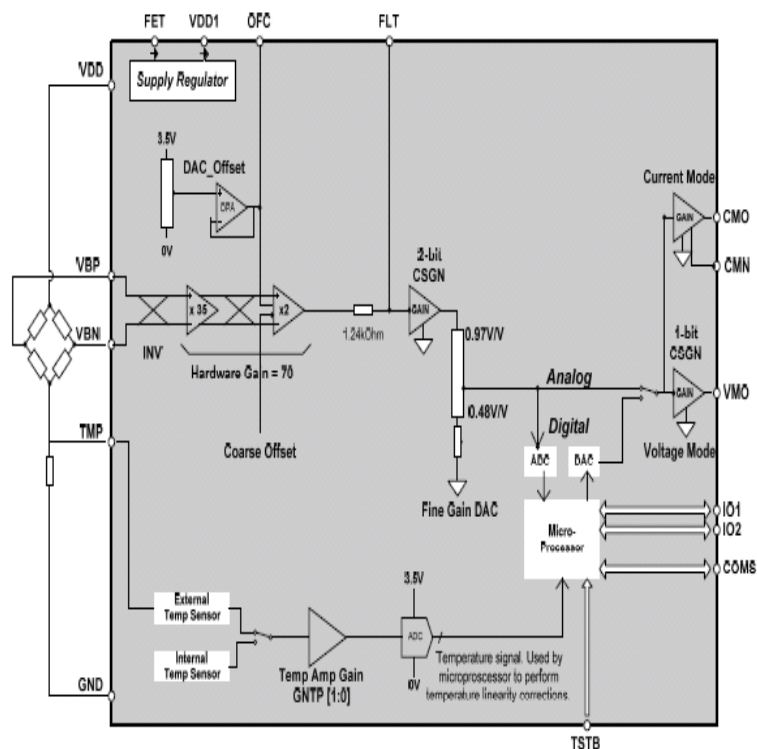

Figure 1. Functional Block Diagram

5. General Description

The MLX90314 is a dedicated microcontroller which performs signal conditioning for sensors wired in bridge or differential configurations. Sensors that can be used include thermistors, strain gauges, load cells, pressure sensors, accelerometers, etc. The signal conditioning includes gain adjustment, offset control, high order temperature and linearity compensation. Compensation values are stored in EEPROM and are re-programmable. Programming is accomplished by using a PC, with an interface circuit (level shifting and glue logic), and provided software.

The application circuits can provide an output of an absolute voltage, relative voltage, or current. The output can be range limited with defined outputs when the signal is beyond the programmed limits. Other features include alarm outputs and level steering. The robust electrical design allows the MLX90314 to be used where most signal conditioning and sensor interface circuits cannot be used. Voltage regulation control is provided for absolute voltage and current modes (external FET required).

The standard package is a plastic SO16W. The device is static-sensitive and requires ESD precautions.

MLX90314

Programmable Sensor Interface

Contents

1. Features and Benefits.....	1
2. Application Examples	1
3. Ordering information	1
4. Functional Diagram	2
5. General Description.....	2
6. Electrical Specifications	4
7. Unique Features	8
7.1. Customization.....	8
7.2. Special Information	8
7.3. Programming and Setup	8
7.4. Cross Reference.....	8
7.5. ESD Precautions	8
8. Pin Description	10
9. Analog Features.....	11
10. Digital Features.....	12
11. Different Modes	13
12. Communications	17
13. Typical 90314 Applications.....	26
14. Standard information regarding manufacturability of Melexis products with different soldering processes	32
15. Contact.....	33
16. Disclaimer.....	33

MLX90314

Programmable Sensor Interface

6. Electrical Specifications

DC operating parameters: $T_A = -40$ to 140°C , $V_{DD1} = 6$ to $35V_{DC}$ (unless otherwise specified).

Parameter	Symbol	Test Conditions	Min	Typ	Max	Units
Regulator & Consumption						
Input voltage range	V_{IN}	V_{DD1} (Regulator connected)	6		35	V
Supply current	I_{DD}	@ $T_A = 100^\circ\text{C}$ Current Mode		2.1		mA
Supply current	I_{DD}	@ $T_A = 100^\circ\text{C}$ Voltage Mode			5.0	mA
Regulated supply voltage	V_{REG}		4.5	4.75	5.2	V
Regulated voltage temperature coefficient				-600		$\mu\text{V} / ^\circ\text{C}$
Supply rejection ratio	PSRR	$V_{DD1} > 6\text{V}$	90			dB
Instrumentation Amplifier						
Differential input range	VBP-VBN	IINV = 0	-2.88		8.38	$\text{mV}/V_{(V_{DD})}$
Differential input range	VBP-VBN	IINV = 1	-8.38		2.88	$\text{mV}/V_{(V_{DD})}$
Common mode input range		$1/2(VBP+VBN)$	38.0		65.0	%VDD
Pin leakage current		Pins VBP & VBN to GND, $V_{DD} =$			8.0	nA
Common mode rejection Ratio	CMRR		60			dB
Hardware gain			69		84	V/V
Coarse offset control Range		CSOF[1:0] = 00	-4.37		-3.97	mV/V
		CSOF[1:0] = 01	-1.46		-1.09	mV/V
		CSOF[1:0] = 10	1.09		1.46	mV/V
		CSOF[1:0] = 11	3.97		4.37	mV/V
Fixed offset control range		High	1.71		2.29	mV/V
		Low	-2.00		-1.43	mV/V
IA chopper frequency				300		kHz
Gain Stage						
Course gain (Fixed Gain = 1023) * CSGN = 100 to 111: voltage mode only, not applicable to current mode. Output > 6.5V; MSB = 1 Output < 6.5V; MSB = 0		CSGN = 000	3.0		3.3	V/V
		CSGN = 001	4.9		5.4	V/V
		CSGN = 010	8.0		8.8	V/V
		CSGN = 011	12.8		14.1	V/V
		CSGN = 100*	7.9		8.7	V/V
		CSGN = 101*	12.7		14.0	V/V

MLX90314

Programmable Sensor Interface



DC operating parameters: $T_A = -40$ to 140°C , $V_{DD1} = 6$ to $35V_{DC}$ (unless otherwise specified).

Parameter	Test Conditions	Min	Typ	Max	Units
Coarse gain	CSGN = 110*	20.4		23.0	V/V
	CSGN = 111*	33.1		36.6	V/V
Fixed gain control range		0.480		0.970	V/V
Digital Mode & Current Mode Coarse Gain Stage					
Course Gain	CSGN = 00	1.05		1.17	V/V
	CSGN = 01	1.71		1.89	V/V
	CSGN = 10	2.77		3.06	V/V
	CSGN = 11	4.48		4.95	V/V
Voltage Mode Output Stage (See Voltage Mode)					
Output voltage span	CSGN[2:2] = 0	4.5		6.5	V
	Gain	2.74		3.04	V/V
	CSGN[2:2] = 1	6.5		11	V
	Gain	7.24		7.86	V/V
Minimum output voltage				-0.2	V
Output source current		2.0			mA
Output sink current	@ 0V output voltage	20			uA
Output resistance	Over complete output range			25	Ohms
Digital mode output span	CSGN[2:2] = 0	6.5			V
	CSGN[2:2] = 1	11.0			V
Digital mode step size	VDD = 5V, CSGN[2:2]=0		6.5		mV
	VDD = 5V, CSGN[2:2]=1		11.0		mV
Capacitive load VMO pin			10		nF
Current Mode Output Stage					
Fixed gain	RSENSE = 24 ohm	8.4		9.3	mA/V
Output current CMO pin	Current mode		27		mA
Current sense resistor			24		Ohms
Digital mode current output span	VDD = 5V	23			mA
Digital mode current step Size	VDD = 5V, RSENSE=24Ω		30		uA
Signal Path (General)					
Overall gain	Voltage mode	98		2100	V/V
	Current mode = 24Ω	284		2625	mA/V
Overall non-linearity		-0.25		0.25	%
Ratiometry Error (4.75V – 5.25V)	Overall Gain < 250V/V	-1.75		1.75	%
	Overall Gain > 250V/V	-4.6		+4.6	%

MLX90314

Programmable Sensor Interface



DC operating parameters: $T_A = -40$ to 140°C , $V_{DD1} = 6$ to $35V_{DC}$ (unless otherwise specified).

Parameter	Test conditions	Min	Typ	Max	Units
Bandwidth (-3dB)	39 nF connected from FLT to GND	2.8	3.5	4.2	KHz
Noise, $V_{DD} = 5V$, $C_{FLT}=39nF$, $C_L=10nF$, $R_L=5K\Omega$, Analog Mode (Max. gain)				17	mVRMS
Temperature Sensor & - Amplifier					
Temperature sensor sensitivity			390		$\mu\text{V}/^{\circ}\text{C}$
Temperature sensor output voltage		70		380	mV
Temperature Sensor & Amplifier (continued).					
Input voltage range TMP pin @ $V_{DD} = 5.0V$	GNTP[1,0] = 00	207		517	mV
	GNTP[1,0] = 01	145		367	mV
	GNTP[1,0] = 10	101		263	mV
	GNTP[1,0] = 11	71		186	mV
DAC					
Resolution			10		Bit
Monotonicity	Guaranteed By Design				
Ratiometric output range (DAC output)		1		75	% V_{DD}
Offset Error			10		LSB
Differential non-linearity				1	LSB
Integral non-linearity				2	LSB
ADC					
Resolution			10		Bit
Monotonicity	Guaranteed by design				
Ratiometric input range		1		75	% V_{DD}
Offset error			10		LSB
Differential non-linearity				1	LSB
Integral non-linearity				2	LSB
On-Chip RC Oscillator and Clock					
Untrimmed RC oscillator frequency		40		250	KHz
Trimmed RC oscillator frequency (Measured at TMP pin with TSTB pin pulled low after power up)		86.9	87.8	88.7	KHz
Frequency temperature coefficient			26		Hz/ $^{\circ}\text{C}$
Clock Stability with temperature compensation over full temperature range		-3		+3	%
Ratio of f (microcontroller main clock and (RC oscillator)	TURBO = 0		7		
	TURBO = 1		28		

MLX90314

Programmable Sensor Interface

DC operating parameters: $T_A = -40$ to 140°C , $V_{DD1} = 6$ to $35V_{DC}$ (unless otherwise specified).

Parameter	Test Conditions	Min	Typ	Max	Units
Input & Output Pins (I01 & I02)					
Digital input levels	Low	0.5			V
	High			$V_{DD}-0.5$	
Output Levels	@ output current = 5mA low	$V_{DD}-0.4$		0.4	V
	@ Output current = 5mA high		V_{DD}		
STB Pin					
Input levels	Low	0.5			V
	High			$V_{DD}-0.5$	
Pull-up Resistor			66		kOhms
FLT Pin					
Output resistance			1.24		kOhms
Output voltage range	$V_{DD} = 5V$	0.05		3.6	V
OFC Pin					
Output voltage range	$V_{DD} = 5V$	0.05		3.75	V
Load capacitor				20	Pf
UART & COMS Pin					
UART baud rate	TURBO = 0		2400		baud
	TURBO = 1		9600		baud
COMS pin input levels	Low	$0.3 \cdot V_{DD}$			V
	High			$0.7 \cdot V_{DD}$	V
COMS Pin Output Resistance	Low		100		Ohms
	High		100		kOhms

MLX90314

Programmable Sensor Interface

7. Unique Features

7.1. Customization

Melexis can customize the MLX90314 in both hardware and firmware for unique requirements. The hardware design provides 64 bytes of RAM, 3 kbytes of ROM, and 48 bytes of EEPROM for use by the firmware.

7.2. Special Information

The output of the sensor bridge is amplified via offset and gain amplifiers and then converted to the correct output signal form in one of the output stages.

The sensitivity and offset of the analog signal chain are defined by numbers passed to the DAC interfaces from the microcontroller core (GN[9:0] and OF[9:0]). The wide range of bridge offset and gain is accommodated by means of a 2-bit coarse adjustment DAC in the offset adjustment (CSOF[1:0]), and a similar one in the gain adjustment (CSGN[2:0]). The signal path can be directed through the processor for digital processing. Two I/O pins are available for analog inputs or digital outputs. These pins can be used for alarms on various points on the analog signal path and built-in or external temperature values.

7.3. Programming and Setup

The MLX90314 needs to have the compensation coefficients programmed for a particular bridge sensor to create the sensor system. Programming the EEPROM involves some minimal communications interface circuitry, Melexis' setup software, and a PC. The communications interface circuitry is available in a development board. This circuitry communicates with the PC via a standard RS-232 serial communications port.

7.4. Cross Reference

There are no known devices which the MLX90314 can replace.

7.5. ESD Precautions

Observe standard ESD control procedures for CMOS semiconductors.

MLX90314

Programmable Sensor Interface

Table 2. Absolute Maximum Ratings

Supply voltage (ratiometric) VDD	6V
Supply voltage (ratiometric) VDD	4.5V
Supply voltage (operating), VDD1	35V
Reverse voltage protection	-0.7V
Supply current, Current Mode, IDD	3.5mA
Supply current, Voltage Mode, IDD	4.5mA
Output current, I _{VMO}	8mA
Output current (short to VDD),	100mA
Output current (short to V _{SS}),	8mA
Output voltage, V _{VMO}	+11V
Power dissipation, P _D	71mW
Operating temperature range, T _A	-40 to +140°
Storage temperature range, T _S	-55 to +150°
Maximum junction temperature, T _J	150°C

MLX90314

Programmable Sensor Interface

8. Pin Description

Table 3 Pin Description

Pin	Signal Name	Description
1,2	I/O1, 2	Bi-directional I/O. Can also be used as input to A/D converter. I/O can be controlled by serial communications or by firmware as alarm inputs or level out. (unconnected when not used)
3	TSTB	Test pin for Melexis production testing. (in normal application connected to VDD)
4	FLT	Filter pin; allows for connection of a capacitor to the internal analog path.
5	OFC	Offset control output. Provides access to the internal programmed offset control voltage for use with external circuitry. (unconnected when not used)
6,7	VBN,VBP	Bridge inputs, negative and positive.
8	TMP	Temperature sensor input. An external temperature sensor can be used in conjunction with the internal one. The external sensor can provide a temperature reading at the location of the bridge sensor.
9	V _{DD}	Regulated supply voltage. Used for internal analog circuitry to ensure accurate and stable signal manipulation.
10	FET	Regulator FET gate control. For generating a stable supply for the bridge sensor and internal analog circuitry (generates regulated voltage for VDD).
11	V _{DD1}	Unregulated supply voltage. Used for digital circuitry and to generate FET output.
12	VMO	Voltage mode output. Compensated sensor output voltage.
13	CMO	Current mode output. Compensated sensor output for current mode operation.
14	CMN	Current mode negative rail. Current mode return path.
15	GND	Power supply return.
16	COMS	Serial communications pin. Bi-directional serial communication signal for reading and writing to the EEPROM.

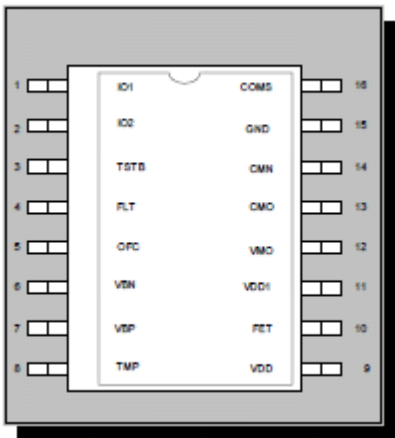

Figure 2. Pinout (SO16W (LW) Package)

MLX90314

Programmable Sensor Interface

9. Analog Features

Supply Regulator

A bandgap-stabilized supply-regulator is on-chip while the pass-transistor is external. The bridge-type sensor is typically powered by the regulated supply (typically 4.75V). For ratiometric operation, the supply-regulator can be disabled by connecting together the unregulated and regulated supply pins.

Oscillator

The MLX90314 contains a programmable on-chip RC oscillator. No external components are needed to set the frequency (87.8 kHz +/-1%). The MCU-clock is generated by a PLL (phase locked loop tuned for 614 kHz or 2.46 Mhz) which locks on the basic oscillator.

The frequency of the internal clock is stabilized over the full temperature range, which is divided into three regions, each region having a separate digital clock setting. All of the clock frequency programming is done by Melexis during final test of the component. The device uses the internal temperature sensor to determine which temperature range setting to use.

A/D and D/A

Conversions using only one DAC

For saving chip area, the "Offset DAC" is multiplexed in various ways. Both "fine offset" and "digital mode" signals are stored on a capacitor. An ADC-loop is available by using a comparator and SAR.

D/A

Before changing to another capacitor, the DAC output should be settled to the new value. For example, MODSEL moves the analog multiplexer to the so-called "open state 0." At the same time, the 10 bit mux selects OF[9:0] for the offset-DAC. After the DAC settling time, the analog multiplexer is moved to its final state and the DAC-output is stored on a capacitor.

A/D

The S/W-Signal MODSEL connects the SAR-output to the DAC and the DAC-output to the comparator. The SARRegister is initialized by a rising edge of STC (S/W signal). At the end of the A/D conversion, the EOC flag is set to 1 and the controller can read the ADC values.

Power-On Reset

The Power-On Reset (POR) initializes the state of the digital part after power up. The reset circuitry is completely internal. The chip is completely reset and fully operational 3.5 ms from the time the supply crosses 3.5 volts. The POR circuitry will issue another POR if the supply voltage goes below this threshold for 1.0 us.

Test Mode

For 100% testability, a "TEST" pin is provided. If the pin is pulled low, then the monitor program is entered and the chip changes its functionality. In all other applications, this pin should be pulled high or left floating (internal pull-up).

Temperature Sense

The temperature measurement, TPO, is generated from the external or internal temperature sensor. This is converted to a 10-bit number for use in calculating the signal compensation factors. A 2-bit coarse adjustment GNT[1:0] is used for the temperature signal gain & offset adjustment.

MLX90314

Programmable Sensor Interface

10. Digital Features

Microprocessor, LX11 Core, Interrupt Controller, Memories

The LX11 microcontroller core is described in its own datasheet. As an overview, this implementation of the LX11 RISC core has following resources:

Two accumulators, one index and two interrupt accumulators.

15 - 8 bit I/O ports to internal resources.

64 byte RAM.

4 kbytes ROM : 3 kbytes is available for the customer's application firmware. 1k is reserved for test.

48 x 8 bit EEPROM.

Four interrupt sources, two UART interrupts and two timers.

UART

The serial link is a potentially full-duplex UART. It is receive-buffered, in that it can receive a second byte before a previously received byte has been read from the receiving register. However, if the first byte is not read by the time the reception of the second byte is completed, the first byte will be lost. The UART's baud rate depends on the RC-oscillator's frequency and the "TURBO"-bit (see output port). Transmitted and received data has the following structure: start bit = 0, 8 bits of data, stop bit = 1.

Sending Data

Writing a byte to port 1 automatically starts a transmission sequence. The TX Interrupt is set when the STOP-bit of the byte is latched on the serial line.

Receiving Data

Reception is initialized by a 1 to 0 transition on the serial line (i.e., a START-bit). The baud rate period (i.e., the duration of one bit) is divided into 16 phases. The first six and last seven phases of a bit are not used. The decision on the bit-value is then the result of a majority vote of phase 7, 8 and 9 (i.e., the center of the bit).

Spike synchronization is avoided by de-bouncing on the incoming data and a verification of the START-bit value. The RX Interrupt is set when the stop bit is latched in the UART.

Timer

The clock of the timers TMI and TPI is taken directly from the main oscillator. The timers are never reloaded, so the next interrupt will take place 2x oscillator pulses after the first interrupt.

Watch Dog

An internal watch dog will reset the whole circuit in case of a software crash. If the watch dog counter is not reset at least once every 26 milliseconds (@ 2.46 MHz main clock), the microcontroller and all the peripherals will be reset.

Firmware

The MLX90314 firmware performs the signal conditioning by either of two means: analog or digital. The analog signal conditioning allows separate offset and gain temperature coefficients for up to four temperature ranges. Digital mode allows for all of the analog capabilities plus up to five different gain values based on the input signal level. Also available in both modes is the capability of range limiting and level steering.

Temperature Processing

In both analog and digital modes, the temperature reading controls the temperature compensation. This temperature reading is filtered as designated by the user. The filter adjusts the temperature reading by factoring in a portion of the previous value. This helps to minimize the effect of noise when using an external temperature sensor. The filter equation is:

```
If measured_temp > Temp_f(n)
then
Temp_f(n+1) = Temp_f(n) + [measured_temp -
Temp_f(n)] / [2n_factor].
```

```
If measured_temp < Temp_f(n),
then
Temp_f(n+1) = Temp_f(n) - [measured_temp -
Temp_f(n)] [2n_factor].
```

Temp_f(n+1) = new filtered temperature value.
Temp_f(n) = previous filtered temperature value.
Measured_temp = Value from temperature A to D.
N_factor = Filter value set by the user (four LSB's of byte 25 of EEPROM), range 0-6.

The filtered temperature value, Temp_f, is stored in RAM bytes 58 and 59. The data is a 10 bit value, left justified in a 16 bit field.

MLX90314

Programmable Sensor Interface

11. Different Modes

Analog Mode

The parameters OF and GN represent, respectively, offset correction and span control, while OFTCi and GNTCi represent their temperature coefficients (thermal zero shift and thermal span shift). After reset, the firmware continuously calculates the offset and gain DAC settings as follows: The EEPROM holds parameters GN, OF, OFTCi and GNTCi, where “i” is the gap number and can be $1 \leq i \leq 4$. The transfer function is described below.

$$V_{out} = FG * DAC_GAIN * CSGN[2:0] * \{Vin + DAC_OFFSET + CSOF\}$$

$$I_{out} = FG * DAC_GAIN * CSGN[1:0] * \{Vin + DAC_OFFSET + CSOF\} * 8.85mA/V$$

FG = Hardware Gain (~72V/V). Part of the hardware design, and not changeable.

CSGN = Course Gain, part of byte 2 in EEPROM.

CSOF = Coarse Offset, part of byte 2 in EEPROM.

GAIN

$$DAC_GAIN \text{ (new value)} \sim GN[9:0] + [GNTCi * dT]$$

GN[9:0] = Fixed Gain, bytes 3 and 17 in EEPROM.

GNTCi = Gain TC for a given temperature segment i. GNTCiL and GNTCiH in EEPROM table.

dT = Temp. change within the appropriate gap. **How**

to calculate gain in the first temp. gap?: DAC_GAIN

$$= GN[9:0] - GNTC1 * (T1 - Temp_f1) \text{ **How to**}$$

calculate gain in the other temp. gaps?:

$$\text{2nd gap: } DAC_GAIN = GN[9:0] + GNTC2 * (Temp_f2 - T1)$$

$$\text{3th gap: } DAC_GAIN = DAC_GAIN2 + GNTC3 * (Temp_f3 - T2)$$

$$\text{4th gap: } DAC_GAIN = DAC_GAIN3 + GNTC4 * (Temp_f4 - T3)$$

Where:

Temp_f = Filtered temp. (previously described).

If $GNTC1 > 2047 \Rightarrow DAC_GAIN$

If $GNTC2,3,4 > 2047 \Rightarrow DAC_GAIN$

OFFSET

$$DAC_OFFSET \text{ (new value)} \sim OF[9:0] + [OFTCi * dT]$$

OF[9:0] = Fixed Gain, bytes 4 and 17 in EEPROM.

OFTCi = Offset for a given temperature segment i. OFTCiL and OFTCiH in EEPROM table.

dT = Temp. change within the appropriate gap.

Calculation of the offset for a given temperature segment is performed the same way as for the gain.

$$(1.83 - 1.57) * \frac{OF[9:0]}{1023} - 1.57 = DAC_OFFSET \text{ [mV/V]}$$

[m

[mV]

$$(0.97 - 0.48) * \frac{GN[9:0]}{1023} + 0.48 = DAC_GAIN$$

Digital Mode

The MLX90314 firmware provides the capability of digitally processing the sensor signal in addition to the analog processing. This capability allows for signal correction.

Signal Correction

While in digital mode the firmware can perform signal correction. This is an adjustment to the output level based on the input signal level. Adjustment coefficients can be set for five different signal ranges. The output is obtained by the following formula:

Output = (Signal - Pi) * Pci + Poff where
Signal = input signal measurement; Poff = Pressure ordinate
Pi = Pressure signal point (i = 2,3,4,5) Pci = programmed coefficient.

The Pci coefficients are coded on 12 bits: one bit for the sign, one for the unity, and the rest for the decimals. The Pi are coded on 10 bits (0-3FFh) in high-low order.

PNB_TNB: contains the number of signal points, coded on the four MSB's. The four LSB's are reserved for the number of temperature points. See Table 4 and Table 5.

MLX90314

Programmable Sensor Interface

Compensation Trade-Offs

A compromise must be made between temperature compensation and pressure correction. The EEPROM space where the signal coefficients are stored is shared with the temperature coefficients, with the result that an EEPROM byte can be used either for a temperature coefficient or for a signal coefficient, but not both. Table 6 presents the possibilities among the maximum number of temperature gaps and the maximum number of signal gaps

**Table 4. PNB_TNB Bit Definition;
Pressure Gaps**

# of Pressure Gaps	4MSB of PNB_TNB Value
Fixed	15 (F hex)
1	14 (E hex)
2	12 (C hex)
3	10 (A hex)
4	8
5	6

**Table 6. Temperature
& Signal Limitations**

Maximum number of temperature gaps	Maximum number of signal gaps
Fixed Gain and fixed Offset	5 Gaps
2 Gaps	3 Gaps
3 Gaps	2 Gaps
4 Gaps	Fixed signal

**Table 5. PNB_TNB Bit Definition;
Temperature Gaps**

# of Temperature Gaps	4 LSB of PNB_TNB
Fixed (1)	0
2 Gaps	5
3 Gaps	8
4 Gaps	11 (B hex)

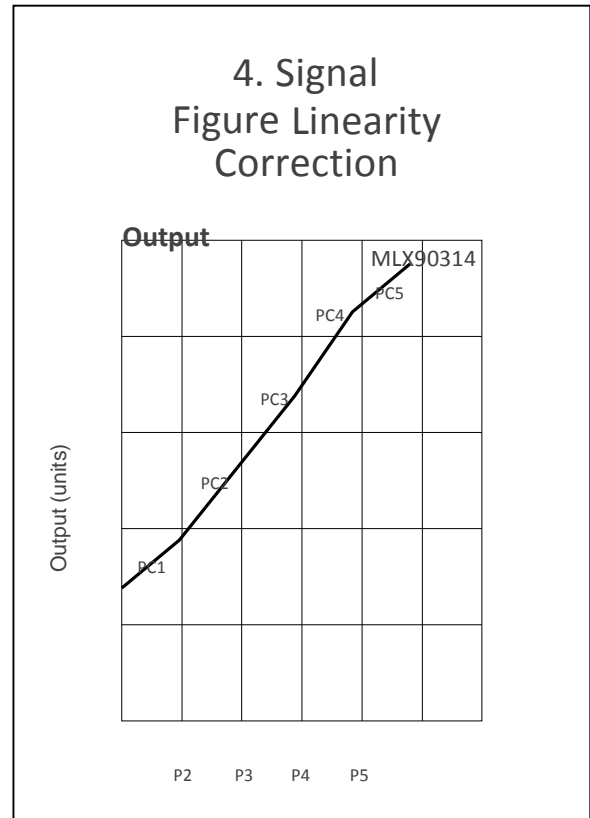
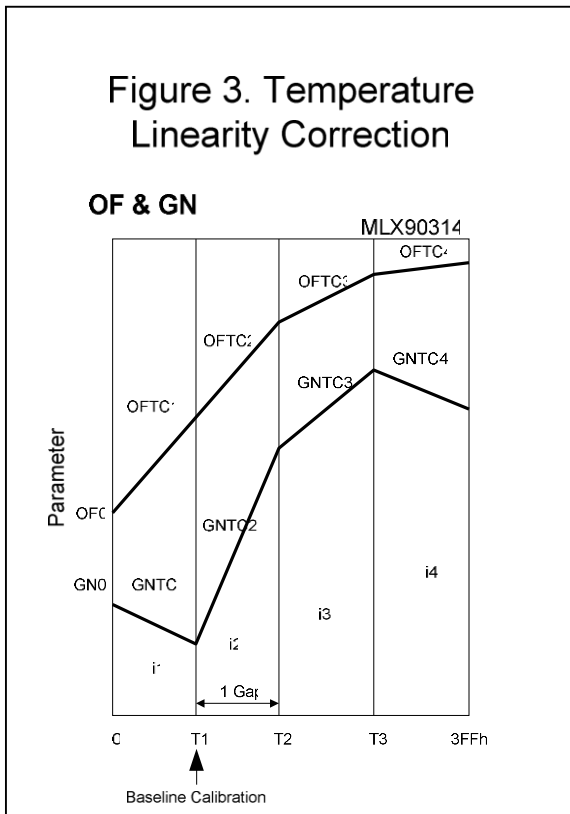

MLX90314

Programmable Sensor Interface

Alarm Option

This option allows controlling the low and high limits of the output (See Figure 5.). The output level is set when the output tries to exceed the programmed limits. Five bytes are reserved for this option. The first byte is the low trigger limit and the second the low output. The third and fourth bytes are used for the high limit and the output. The fifth byte is the alarm control, used to select the alarm input. The different levels are programmed as eight bit numbers. These correspond to the 8 upper bits of the 10 bit signal measurement. When the alarm mode is not used, all of the data is 0. The control code is coded as shown in Table 7. The six possible signals are listed below and are encoded on the 4 MSB's of byte 31 of the EEPROM.

Table 7. Alarm Source Bit Definition

Selected input	MUX Value
TPO	0010
IAO	0110
GNO	0000
VMO	0011
IO1	0100
IO2	0101

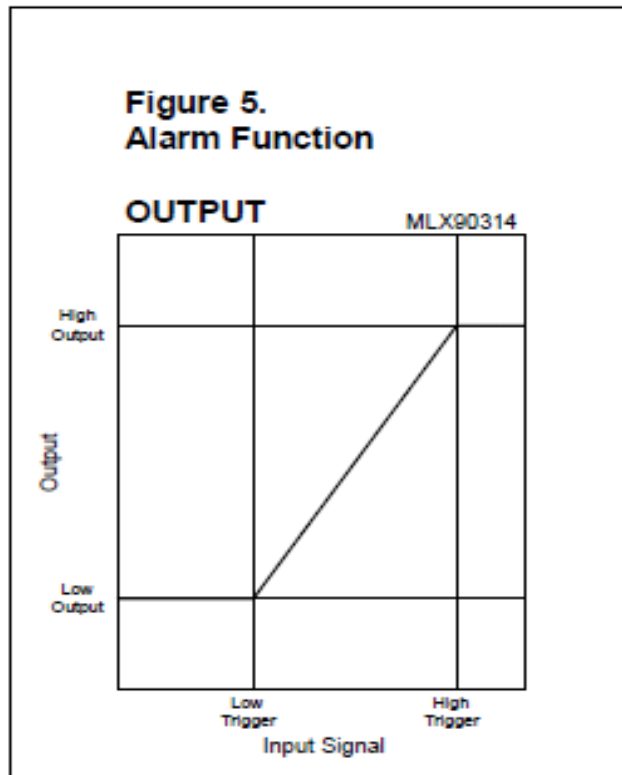

IO1 & IO2

IO1 and IO2 are used in the alarm and level steering modes. For custom firmware, they can be used for a digital input, an analog input, or a digital output.

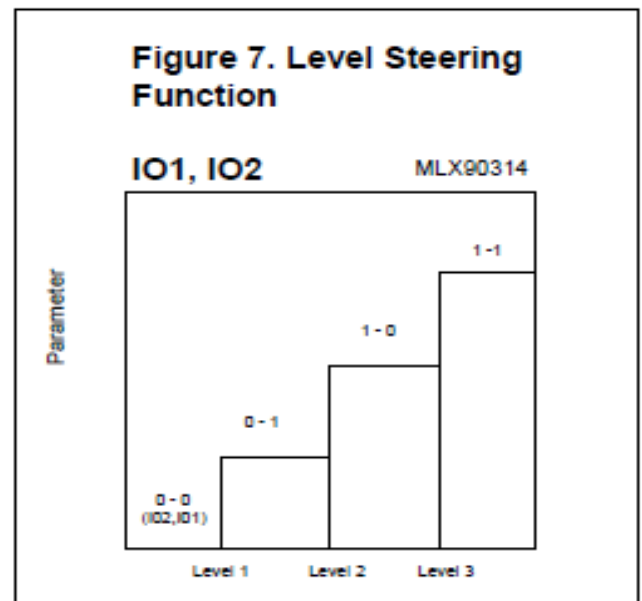
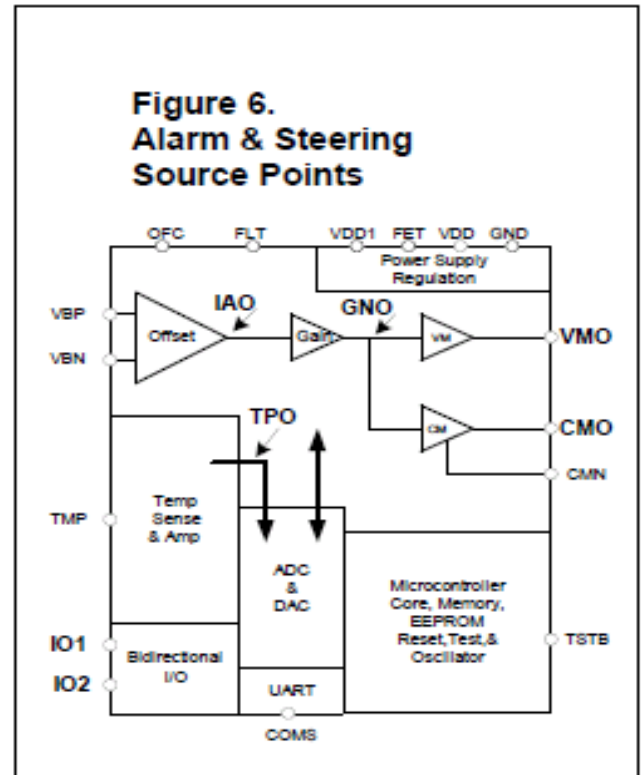

Level Steering

The level steering option allows configuration of the IO pins as outputs to indicate the relative level of a selected signal. See Figure 7. The levels at which the two outputs change state are programmed by the user. The programmed levels are set as eight bit numbers and compared to the upper eight bits of the digitized signal. This function utilizes the same resources as the alarm function. The two functions (level steering and alarm) cannot be used simultaneously. Four bytes in the EEPROM command this option. The first byte is used to select the input, while the last three comprise the transition levels. The control byte for the level steering is the same as for the alarm. The four MSB's hold the code for the selected input. The control byte has several possibilities as designated by the MUX settings (See Table 8)

Table 9. Mode Byte Bit Definition

Bit	Function	Remarks
7	1= EEPROM Checksum test active 0= EEPROM Checksum test inactive	EEPROM Checksum test. Checksum test failure will force the output to the value programmed in bytes 40 and 41 of the EEPROM (See Table 10).
6	0 = Analog Mode 1 = Digital Mode	Digital mode must be activated when VMO and CMO both active.
5	0 = Alarm function inactive 1 = Alarm function active	Alarm functions are like "limiting functions": If defined ADC INPUT is <u>below</u> low alarm trigger, then DIGMOD becomes active with alarm low output). If defined ADC INPUT is <u>above</u> high alarm trigger, then DIGMOD becomes active with alarm high output. Note: Deactivated if the level steering mode is active
4	0 = IO1/IO2 are not active outputs 1 = level steering: IO1/IO2 are active outputs	Depending on the sampled input, IO1/IO2 will be a two bit digital output. If IO1/IO2 are not active outputs, then they will be analog inputs.
3	0 = Turbo inactive 1 = Turbo active	
2	0 = VMO inactive 1 = VMO active	
1	0 = Internal temperature sensor active 1 = External temperature sensor active	
0	0 = CMO inactive 1 = CMO active	CMO has fixed digital value (EEPROM byte - see below) if both VMO and CMO are active. To activate this value, the digital mode must be activated.

12. Communications

The MLX90314 firmware transfers a complete byte of data into and from the memory based on a simple command structure. The commands allow data to be read and written to and from the EEPROM and read from the RAM. RAM data that can be read includes the current digitized temperature and digitized GNO. The commands are described below. Melexis provides setup software for programming the MLX90314.

Table 8. Level Steering Bit Definitions

Selected input	MUX Value
TPO	0010
IAO	0110
GNO	0000
VMO	0011

UART Commands

The commands can be divided into three parts: (1) downloading of data from the ASIC, (2) uploading of data to the ASIC and (3) the reset command.

All the commands have the same identification bits. The two MSB's of the sent byte indicate the command while the last six MSB's designate the desired address. The commands are coded as followed:

- 11 to read a RAM byte.
- 10 to read an EEPROM byte.
- 01 to write in the EEPROM.
- 00 to write in the RAM.

The addresses can include 0-63 for the RAM, 0-47 for the EEPROM, and 63 for the EEPROM, RESET Command (read).

Downloading Command

With one byte, data can be downloaded from the ASIC. The ASIC will automatically send the value of the desired byte.

Uploading Command

Writing to the RAM or EEPROM involves a simple handshaking protocol in which each byte transmitted is acknowledged by the firmware. The first byte transmitted to the firmware includes both command and address. The firmware acknowledges receipt of the command and address byte by echoing the same information back to the transmitter. This "echo" also indicates that the firmware is ready to receive the byte of data to be stored in RAM or EEPROM. Next, the byte of value to be stored is transmitted and, if successfully received and stored by the firmware, is acknowledged by a "data received signal," which is two bytes of value BCh. If the "data received signal" is not observed, it may be assumed that no value has been stored in RAM or EEPROM.

Reset Command

Reading the address 63 of the EEPROM resets the ASIC and generates a received receipt indication. Immediately before reset, the ASIC sends a value of BCh to the UART, indicating that the reset has been received.

EEPROM Data

All user-settable variables are stored in the EEPROM within the MLX90314. The EEPROM is always re-programmable. Changes to data in the EEPROM do not take effect until the device is reset via a soft reset or power cycle. 12 bit variables are stored on 1.5 bytes. The 4 MSB's are stored in a separate byte and shared with the four MSB's of another 12-bit variable.

Clock Temperature Stabilization

To provide a stable clock frequency from the internal clock over the entire operating temperature range, three separate clock adjust values are used. Shifts in operating frequency over temperature do not effect the performance but do, however, cause the communications baud rate to change.

The firmware monitors the internal temperature sensor to determine which of three temperature ranges the device currently is in. Each temperature range has a factory set clock adjust value, ClkTC1, ClkTC2, and ClkTC3. The temperature ranges are also factory set. The Ctemp1 and Ctemp2 values differentiate the three ranges. In order for the temperature A to D value to be scaled consistently with what was used during factory programming, the CLKgntp (temperature amplifier gain) valued is stored. The Cadj value stored in byte 1 of the EEPROM is used to control the internal clock frequency while the chip boots.

Unused Bytes

There are eight unused bytes in the EEPROM address map. These bytes can be used by the user to store information such as a serial number, assembly date code, production line, etc. Melexis doesn't guarantee that these bytes will be available to the user in future revisions of the firmware.

EEPROM Checksum

A checksum test is used to ensure the contents of the EEPROM. The eight bit sum of all of the EEPROM addresses should have a remainder of 0FFh when the checksum test is enabled (mode byte). Byte 47 is used to make the sum remainder totals 0FFh. If the checksum test fails, the output will be driven to a user defined value, Faultval. When the checksum test is enabled, the checksum is verified at initialization of RAM after a reset.

RAM Data

All the coefficients (pressure, temperature) are compacted in a manner similar to that used for the EEPROM. They are stored on 12 bits (instead of keeping 16 bits for each coefficient). All the measurements are stored on 16 bits. The user must have access to the RAM and the EEPROM, while interrupt reading of the serial port. Therefore, bytes must be kept available for the return address, the A-accu and the B-accu, when an interrupt occurs. The RAM keeps the same structure in the both modes.

Table 10. Examples of Fixed Point Signed Numbers

Decimal Value	Hexadecimal Equivalent	Fixed Point Signed Number Equivalent
0	0000h	+0.00
1023	3FFh	+0.9990234
1024	400h	+1.000
2047	7FFh	+1.9990234
2048	800h	-0.000
3071	0BFFh	-0.9990234
3072	0C00h	-1.000
4095	0FFFh	-1.9990234

Data Range

Various data are arranged as follows:

Temperature points: 10 bits, 0-03FF in high-low order.

Pressure points: 10 bits, 0-03FF in high-low order.

GN1: 10 bits, 0-03FF in high-low order.

OF1: 10 bits, 0-03FF in high-low order.

GNTCi: signed 12 bits (with MSB for the sign), [-1.9990234, +1.9990234].

OFTCi: signed 12 bits (with MSB for the sign), [-1.9990234, +1.9990234].

Pci: signed 12 bits (with MSB for the sign), [-1.9990234, +1.9990234].

DIGMO: 10 bits, 0-03FF in high-low order (See Table 13 for examples of fixed point signed numbers.)

Table 11. EEPROM Byte Definitions

Byte	Designation	Note
0	MODE byte	Contents described in Table 9.
1	Cadj	Controls system clock during boot.
2	Coarse Control	Contents described in Table 12.
3	GN1L	The eight LSB's of the Fixed Gain, GN[7:0].
4	OF1L	The eight LSB's of Fixed Offset OF[7:0].
5	GNTC1L	The eight LSB's of the first gain TC GNTC1[7:0].
6	OFTC1L	The eight LSB's of the first offset TC OFTC1[7:0].
7	TR1L PC5L	The eight LSB's of the first temperature point, T1[7:0]. The eight LSB's of Pressure Coefficient 5 PC5[7:0].
8	GNTC2L P5L	The eight LSB's of the second gain TC GNTC2[7:0]. The eight LSB's of Pressure Point 5 P5[7:0].
9	OFTC2L PC4L	The eight LSB's of the second offset TC OFTC2[7:0]. The eight LSB's of Pressure Coefficient 4 PC4[7:0].
10	TR2L P4L	The eight LSB's of the second temperature point T2[7:0]. The eight LSB's of Pressure Point 4 (or Signature) P4[7:0].
11	GNTC3L PC3L	The eight LSB's of the third gain TC GNTC3[7:0]. The eight LSB's of Pressure Coefficient 3 (or Signature) PC3 [8:0].

Table 11. EEPROM Byte Definitions (continued)

Byte	Designation	Note
12	OFTC3L or P3L	The eight LSB's of the third offset TC OFTC3[7:0]. The eight LSB's of Pressure Point 2 (or Signature) P2[7:0].
13	TR3L or PC2L	The eight LSB's of the third temperature point T3[7:0]. The eight LSB's of Pressure Coefficient 2 PC2[7:0].
14	GNTC4L or P2L	The eight LSB's of the fourth gain TC GNTC4[7:0]. The eight LSB's of Pressure Point 2 P2[7:0].
15	OFTC4L or PC1L	The eight LSB's of the fourth offset TC OFTC4. The eight LSB's of Pressure Coefficient 1 PC1
16	PoffL	The eight LSB's of Pressure (output signal) Ordinate Poff[7:0].
	Upper Four Bits	Upper four bits.
	Lower Four Bits	Lower four bits
17	GN1[9:8] OF1[9:8]	Two MSB's of fixed gain GN[9:8]. Two MSB's of fixed offset OF[9:8]
18	GNTC1[11:8] OFTC1[11:8]	Four MSB's of first gain TC GNTC1[11:8]. Four MSB's of the first offset TC OFTC1[11:8].
19	TR1[9:8] GNTC2[11:8] PC5[11:8] P5[9:8]	Two MSB's, first temperature point T1[9:8] or Four MSB's, Pressure Coefficient 5 PC5[11:8]. Four MSB's, second gain TC GNTC2[11:8] or TC GNTC2[11:8] or Two MSB's Pressure Point 5 P5[9:8].
20	OFTC2[11:8] TR2[9:8] PC4[11:8] P4[9:8]	Four MSB's second offset TC OFTC2[11:8] or Four MSB's Pressure Coefficient 4 PC4[11:8]. Two MSB's second temperature point T2[9:8] or Two MSB's Pressure Point 4 P4[9:8].
21	GNTC3[11:8] OFTC3[11:8] PC3[11:8] P3[9:8]	Four MSB's third gain TC GNTC3[11:8] or Four MSB's Pressure Coefficient 3 PC3[11:8]. Four MSB's third offset TC OFTC3[11:8] or Two MSB's Pressure Point 3 P3[9:8].
22	TR3[9:8] GNTC4[11:8] PC2[9:8] P2[9:8]	Two MSB's third temperature point t3[9:8] or Four MSB's Pressure Coefficient 2 PC2[11:8]. Four MSB's fourth gain TC GNTC4[11:8] or Two MSB's Pressure Point 2 P2[9:8].
23	OFTC4[11:8] Poff[9:8] PC1[11:8]	Four MSB's fourth offset TC ordinate OFTC4[11:8] or Four MSB's Pressure Coefficient 1 PC1[11:8]. Two MSB's Pressure Poff[9:8].

Table 11. EEPROM Byte Definitions (continued)

Byte	Designation	Note
24	PNB_TNB	Number of temperature and pressure gaps. See Tables 4, 5, and 6, and Figures 3 and 4.
25	n_factor	Temperature filter coefficient, four LSB's. Four MSB's must all be zero.
26	Not used	This byte is not used.
27	ALARM low trigger Level1 IO2/IO1	Value below which ALARM will go on. Value of first level ([IO2, IO1]= 00-01). See Figures 5 & 7.
28	ALARM low output Level2 IO2/IO1	Value of DIGMO during "ALARM low" condition. Value of second level ([IO2, IO1] = 01-10). See Figures 5 and 7
29	ALARM high trigger Level3 IO2/IO1	Value above which ALARM will go on. Value of third level ([IO2, IO1]=10-11). See Figures 5 and 7.
30	ALARM high out level	Value of DIGMO during "ALARM high" condition. See Figures 5 and 7.
31	ALARM control byte IO1/IO2 control byte Four LSB's are unused	Three bits needed for choice of input for ALARM detection (TPO, IAO, GNO, VMO, IO1 or IO2). Two bits needed for choice of input for LEVEL-steering (TPO, IAO, GNO or VMO). The above bits are multiplexed according to the mode. If both CMO and VMO are active, then alarm is not active.
32	ClkTC1	Value of Cadj at low temperature (Don't change; factory set).
33	ClkTC2	Value of Cadj at mid temperature (Don't change; factory set).
34	ClkTC3	Value of Cadj at high temperature Don't change; factory set).
35	Ctemp1	First Cadj temperature point, eight MSB's of the 10 bit internal temperature value (set at factory; do not change).
36	Ctemp2	Second Cadj temperature point, eight MSB's of the 10 bit internal temperature value (set at factory; do not change).
37-38	Not used	These bytes are not used by the firmware and are available to the user.
39	CLKgntp	Setting for temperature amplifier for clock temperature adjustment temperature reading (set at factory; do not change).
40-41	Faultval	Value sent to output if checksum test fails is a 10 bit value.
42-46	Not Used	These bytes are not used by the firmware and are available to the user.
47	Checksum	EEPROM checksum; value needed to make all bytes add to 0FFh. Must be set by user if checksum test is active.

Notes For Table 11

1. Not all the temperature and pressure coefficients must be used. When a coefficient is unused, the eight LSB's and the four MSB's are replaced by 0.

2. The level steering and the alarm mode cannot be active simultaneously because the levels bytes are shared with the two modes.

3. If the alarm mode and the level steering are both active, the level steering mode is dominant. The firmware will run with the level steering mode, by default.

4. If the DIGMO mode (VMO and CMO both active) is active, the alarm will be automatically disabled by the firmware.

5. At PNB_TNB address, the four MSB's correspond to the address of the last pressure point and the four LSB's to the address of the last temperature point.

6. In the alarm_control variable, the selected input is stored on the three MSB's.

7. Pi and OFi are 10 bit values, right justified in 12 bits fields.

**Table 12. Bit Definitions;
Coarse Control , Byte 2**

Bit	Symbol	Function
7	IINV	Invert signal sign.
6	GNTP1	Gain & offset of temperature amplifier.
5	GNTP0	GNTP = 0 to 3.
4	CSOF 1	Coarse offset of signal amplifier.
3	CSOF 0	CSOF = 0 to 3.
2	CSGN2	Coarse gain of signal amplifier. CSGN = 0 to 7. If CSGN > 3, output range = 0 to 10V. If CSGN <= 3, output range = 0 to 5V.
1	CSGN1	
0	CSGN0	

Table 13. RAM Byte Definitions

Byte	Functions	Remarks
0	MODE byte	See Table 9.
1	GN1L	Fixed gain number (8LSB).
2	OF1L	Fixed offset number (8LSB).
3	GNTC1L	First gain TC (8LSB).
4	OFTC1L	First offset TC (8LSB).
5	TR1L PC5L	First temperature point. Pressure Coefficient 5 (8LSB).
6	GNTC2L P5L	Second gain TC. Pressure point 5 (8LSB).
7	OFTC2L PC4L	Second offset TC. Pressure coefficient 4 (8LSB).
8	TR2L P4L	Second temperature point. Pressure Point 4 (or Signature) (8LSB).
9	GNTC3L PC3L	Third gain TC. Pressure Coefficient 3 (or Signature) (8LSB).
10	OFTC3L P3L	Third offset TC. Pressure Point 2 (or Signature) (8LSB).

MLX90314

Programmable Sensor Interface

Byte	Functions	Remarks
11	TR3L	Third temperature point.
	PC2L	Pressure Coefficient 2 (8LSB).
12	GNTC4L	Fourth gain TC.
	P2L	Pressure Point 1 (8LSB).
13	OFTC4L	Fourth offset TC.
	PC1L	Pressure Coefficient 1 (8LSB).
14	DIGMOP1L	Fixed pressure (8LSB).
15	GN1[9:8] OF1[9:8]	Two MSB's of fixed gain GN[9:8]. Two MSB's of fixed offset OF[9:8].
16	GNTC1 OFTC1 [11:8] [11:8]	Four MSB's of first gain TC GNTC1[11:8]. Four MSB's of the first offset TC OFTC1[11:8]
17	TR1[9:8] GNTC2 [11:8]	Two MSB's, first temperature point T1[9:8] or Four MSB's, second gain TC GNTC2[11:8] or
	PC5[11:8] P5[9:8]	Four MSB's Pressure Coefficient 5 PC5[11:8]. Two MSB's, Pressure Point 5 P5[9:8]
18	OFTC2[11:8] TR2[9:8]	Four MSB's, second offset TC OFTC2[11:8] or Two MSB's, second temp. point T2[9:8] or
	PC4[11:8] P4[9:8]	Four MSB's, Pressure Coefficient 4 PC4[11:8]. Two MSB's, Pressure Point 4 P4[9:8].
19	GNTC3[11:8] OFTC3 [11:8]	Four MSB's, Third Gain TC GNTC3[11:8] or Four MSB's Third Offset TC OFTC3[11:8] or
	PC3[11:8] P3[9:8]	Four MSB's, Pressure Coefficient 3 PC3[11:8]). Two MSB's Pressure Point 3 P3[9:8]
20	TR3[9:8] GNTC4 [11:8]	Two MSB's, third temperature point t3[9:8] or Four MSB's, Fourth Gain TC GNTC4[11:8] or
	PC2[9:8] P2[9:8]	Four MSB's, Pressure Coefficient 2 PC2[11:8]. Two MSB's, Pressure Point 2 P2[9:8].
21	OFTC4[11:8] P1[9:8]	Four MSB's Fourth Offset TC OFTC4[11:8] or Two MSB's Pressure Point 1 P1[9:8].
	PC1[11:8]	Four MSB's Pressure Coefficient 1 PC1[11:8].
22	PNB_TNB	Same as EEPROM.
23	N_Factor	Temperature filter coefficient — 4 LSB's, 4 MSB = 0
24	Not Used	
25-26	GN	Offset Ordinate of the current gap.
27-28	OF	Gain Ordinate of the current gap.
29	Address	4 bits for the max. temperature address of the current gap; 4 bits for the min. temperature address of the current gap.

MLX90314

Programmable Sensor Interface

Byte	Functions	Remarks
30	ALARM control byte IO1/IO2 control byte	Three bits needed for choice of input for ALARM detection (TPO, IAO, GNO, VMO, IO1 or IO2). Two bits needed for choice of input for LEVEL-steering (TPO, IAO, GNO or VMO). These bits are multiplexed according the mode. Note: if both CMO and VMO are active, then alarm is not active.
31	ALARM low trigger level IO1/IO2 level 1	Value below which ALARM will go on. Value of first level ([IO2,IO1]=00-01).
32	ALARM low output level IO1/IO2 level 2	Value of DIGMO during "ALARM low" condition. Value of second level ([IO2,IO1]=01-10).
33	ALARM high trigger level IO1/IO2 level 3	Value above which ALARM will go on. Value of third level ([IO2,IO1] = 10-11).
34	ALARM high output level	Value of DIGMO during "ALARM high" condition.
35-36	A_16	16 bits A Register.
37-38	B_16	16 bits B Register.
39-42	RESULT_32	32 bits result (for 16 bit multiplication).
43-44	Tempo1	Measured temperature, internal or external, and temporary variable 1.
45	Tempo2	Temporary variable 2.
46-47	Signal_In	Digitized signal value, analog and digital mode
48	Coms_backup	Address saved when command is send.
49	P3_copy	Port 3 setting copy.
50	Adsav1	Address saved at interrupt.
51-52	Aaccsav	A-Accumulators saved at interrupt.
53	Baccsav	B-Accumulators saved at interrupt.
54-55	DAC_gain	DAC gain (GN).
56-57	DAC_offset	DAC offset (OF).
58-59	Temp_f	Filtered temperature. This is a 10 bit number that is left justified in a 16 bit field.
60-61	Signal_Out	Digitized linearity corrected signal value. Digital mode only.
62-63	Adsav2	Address saved when call.

Note: Because of space considerations, the measured temperature can't be kept in the RAM at all times. If the measured temperature is to be available, the temperature filter variable, N_Factor, must be set to 6.

MLX90314

Programmable Sensor Interface

Prototyping

Melexis offers an MLX90314 evaluation kit which contains an evaluation circuit board, serial interface cable, and software diskette. The circuit board provides the necessary circuitry for all three applications circuits shown on the next page. Also included in the circuit board is level shifting and glue logic necessary for RS-232 communications.

The board has a socket with a single MLX90314 installed, and direct access to the pins of the IC. The user can easily attach bridge sensor to the board for in-system evaluation. The serial interface cable connects the evaluation board directly to a PC's serial port for in-system calibration.

The software runs in the familiar Windows platform and allows for programming and evaluation of all compensation parameters within the EEPROM.



Figure 8. MLX90314 Evaluation Kit with MLX Software

Edit Parameters - MLX90308D & MLX90314B

MODE

- Voltage Mode
- Current Mode
- Turbo
- Analog Mode
- Digital Mode
- Level Steering
- Alarm Mode
- Internal Temp
- External Temp
- Checksum Test

Alarm /Level Steering

Low Trigger /Level-1 (0-255) High Trigger /Level-3 (0-255)

Low Output /Level-2 (0-255) High Output (0-255)

Source

- TPO
- IAIO
- IO1
- GNO
- VMO
- IO2

Temp Amp Gain (0-3) Invert Signal

Coarse Offset (0-3)

Coarse Gain (0-7)

Fixed Gain (0-1023)

Fixed Offset (0-1023)

Filter (0-6)

Checksum Checksum Error Output (0-1023)

Temp Gaps (1-4) = Signal Gaps (0-5) =

Gap	1	2	3	4	5
Temp (0-1023)	<input type="text" value="0"/>	<input type="text" value="0"/>	<input type="text" value="0"/>	<input type="text" value="0"/>	<input type="text" value="0"/>
GNTC (0-4095)	<input type="text" value="0"/>	<input type="text" value="0"/>	<input type="text" value="0"/>	<input type="text" value="0"/>	<input type="text" value="0"/>
OFTC (0-4095)	<input type="text" value="0"/>	<input type="text" value="0"/>	<input type="text" value="0"/>	<input type="text" value="0"/>	<input type="text" value="0"/>
P (0-1023)	<input type="text" value="0"/>	<input type="text" value="0"/>	<input type="text" value="0"/>	<input type="text" value="0"/>	<input type="text" value="0"/>
PC (0-4095)	<input type="text" value="0"/>	<input type="text" value="0"/>	<input type="text" value="0"/>	<input type="text" value="0"/>	<input type="text" value="0"/>

Update Temp Value =

Signal In Value =

Signal Out Value =

Upload EEPROM Reset Controller OK Cancel Help

MLX90314

Programmable Sensor Interface

13. Typical 90314 Applications

Figure 9a. Absolute Voltage Mode

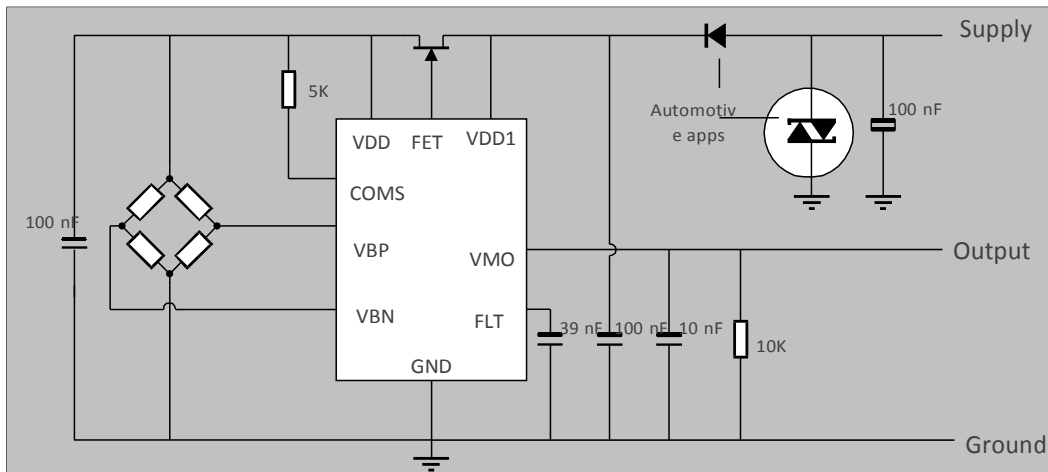
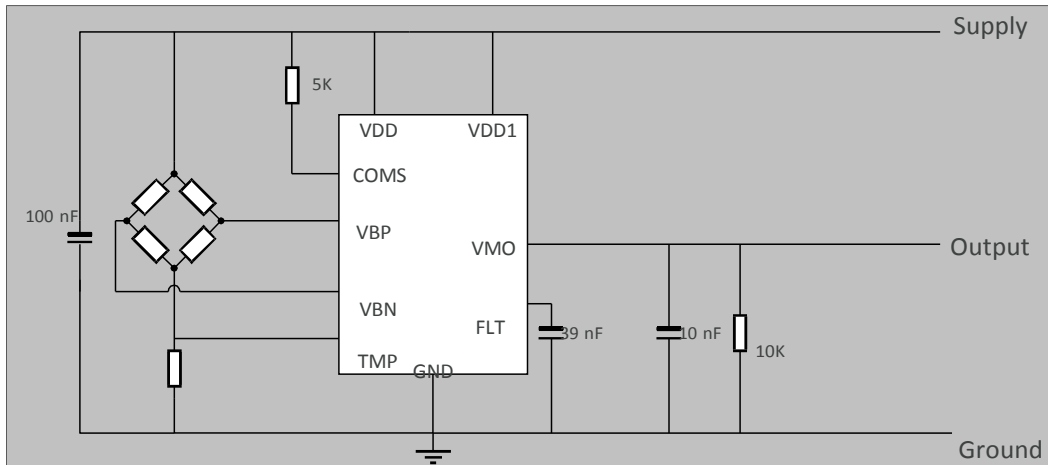

Figure 9b. Ratiometric Voltage Mode



MLX90314

Programmable Sensor Interface

Figure 9c. Current Mode

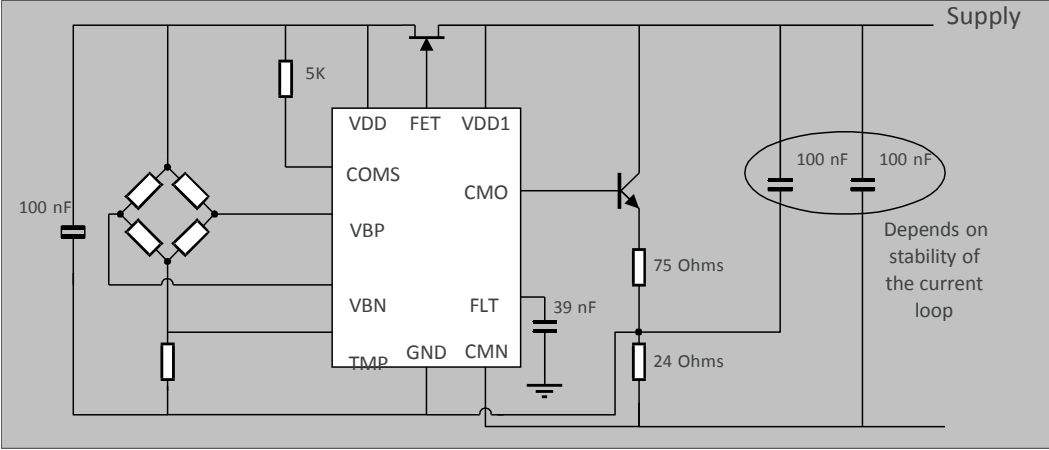

MLX90314

Programmable Sensor Interface

Figure 10. Application Example

Figure 10a. Programmable Oil Pressure Gauge

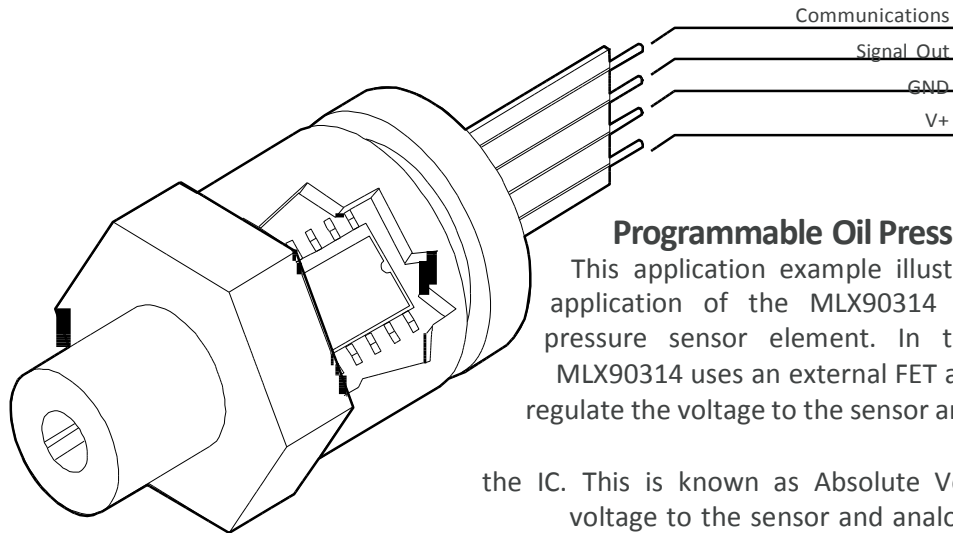

Programmable Oil Pressure Gauge

This application example illustrates a fundamental application of the MLX90314 and a bridge type pressure sensor element. In this application, the MLX90314 uses an external FET as a pass transistor to regulate the voltage to the sensor and the analog portion of the IC. This is known as Absolute Voltage Mode, where voltage to the sensor and analog circuit is regulated independent of the supply voltage. The MLX90314 can be operated in Ratiometric Voltage Mode, in which the output (VMO) is tied to an A/D converter sharing the same supply and ground reference. A third wiring option is Current Mode, which allows the user a 4 to 20 milliampere current range to use as a 2-wire analog sensor.

Figure 10b. Programmable Oil Pressure Gauge Electrical Connections

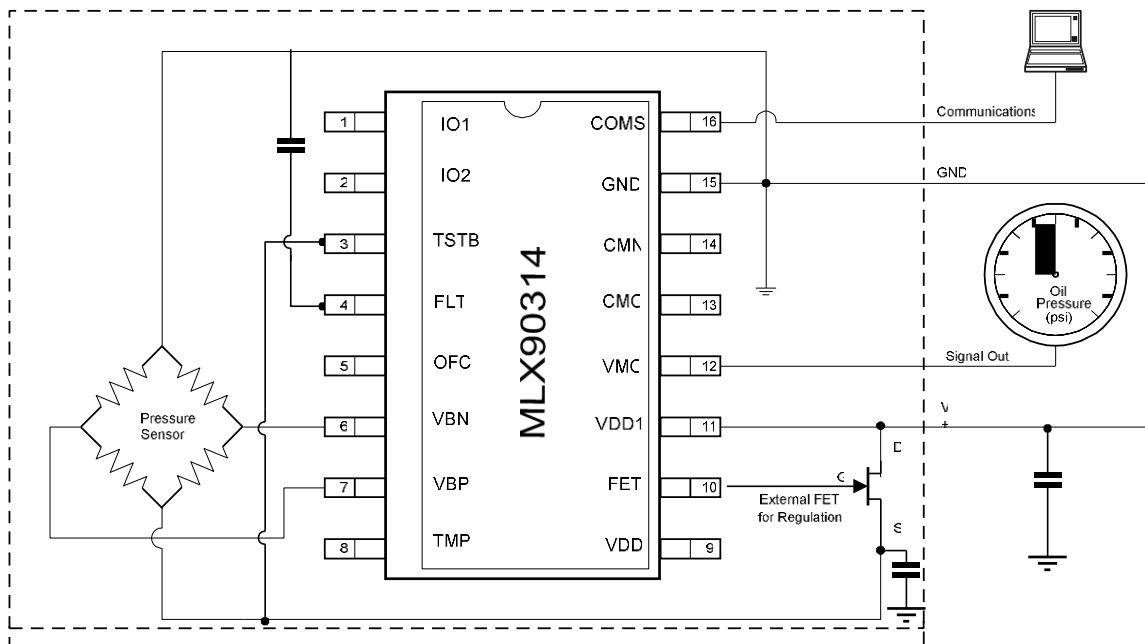

MLX90314

Programmable Sensor Interface

Figure 11. Error Compensation

Figure 11a. Raw Sensor Output (measured between VPB and VBN)

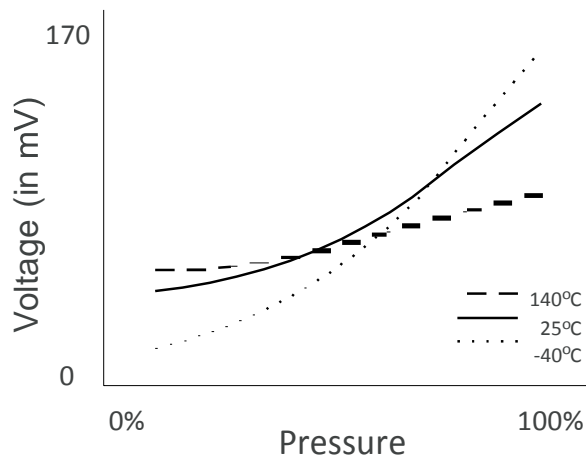
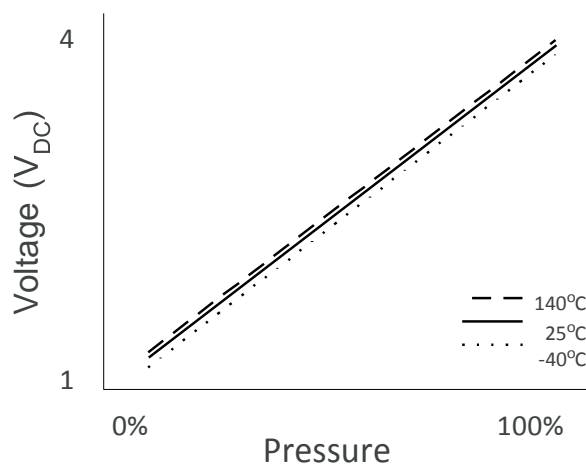

Figure 11b. Conditioned Sensor Output



Figures 11a and 11b above illustrate the performance of an unconditioned sensor output and a conditioned sensor output versus stimulus (pressure) and temperature. It can be seen that Figure 11a has a range of only 170 mV (maximum range with a 5V supply) and has a non-linear response over a 0-100 psi range. The sensitivity of the unconditioned output will also drift over temperature, as illustrated by the three slopes. The MLX90314 corrects these errors and amplifies the output to a more usable voltage range as shown in Figure 11b.

MLX90314

Programmable Sensor Interface

Table 14. Glossary of Terms

A/D	analog to digital conversion	RS-232	industry std. serial communications protocol
ADC	analog to digital converter	RX	receive
ASCII	American Standard Code for Information Interchange	SAR	successive approximation register
ASIC	application specific integrated circuit	STC	start A/D conversion
CM	current mode	Tdiff	temperature difference
CMN	current mode negative (supply connection)	Text	temperature, external TMI
CMO	current mode output	timer	Interrupt
COMS	communication, serial carriage	TMP	temperature signal
CR	return	TPI	temperature interrupt
CSGN	coarse gain	Tref	temperature reference
CSOF	coarse offset	TSTB	test mode pin
CV	current / voltage mode select bit	TX	transmit
DAC	digital to analog converter	UART	universal asynchronous receiver / transmitter
DACFnew	filtered DAC value, new	VBN	bridge, positive, input
DACFold	filtered DAC value, old	VBP	bridge, negative, input
DARDIS	DAC resistor disable	VDD	supply voltage
dB	decibel	VM	voltage mode
DOGMO	digital mode	VMGN	voltage mode gain
EEPROM	electrically erasable programmable read only memory	VMO	voltage mode output
EOC	end of conversion flag	WCB	warn / cold boot
ESD	electrostatic discharge	WDC	watch dog counter
ETMI	timer interrupt enable		
ETPI	enable temperature interrupt		
FET	field effect transistor		
FG	fixed gain		
FLT	filter pin		
GNO	gain and offset adjusted digitized signal		
GNOF	gain, offset		
GNTF	temperature gain / offset coarse adjustment		
HS	hardware / software limit		
I/O	input / output		
IFIX	fixed current output value		
IINV	input signal invert command bit		
ILIM	current limit		
kHz	kilohertz, 1000 Hz		
LSB	least significant bit		
mA	milliamperes, 0.001 amps		
MODESEL	mode select		
ms	millisecond, 0.001 second		
MSB	most significant bit		
MUX	multiplexer		
mV	millivolts, 0.001 Volts		
nF	nanofarads, 1 X 10 ⁻⁹ farads		
OFC	offset control		
PC	personal computer, IBM clone		
pF	picofarad, 1 X 10 ⁻¹² farads		
PLL	phase locked loop		
POR	power on reset		
RAM	random access memory		
RISC	reduced instruction set computer		
ROM	read only memory		

MLX90314

Programmable Sensor Interface

Figure 12. MLX90314 Physical Characteristics, DF Package

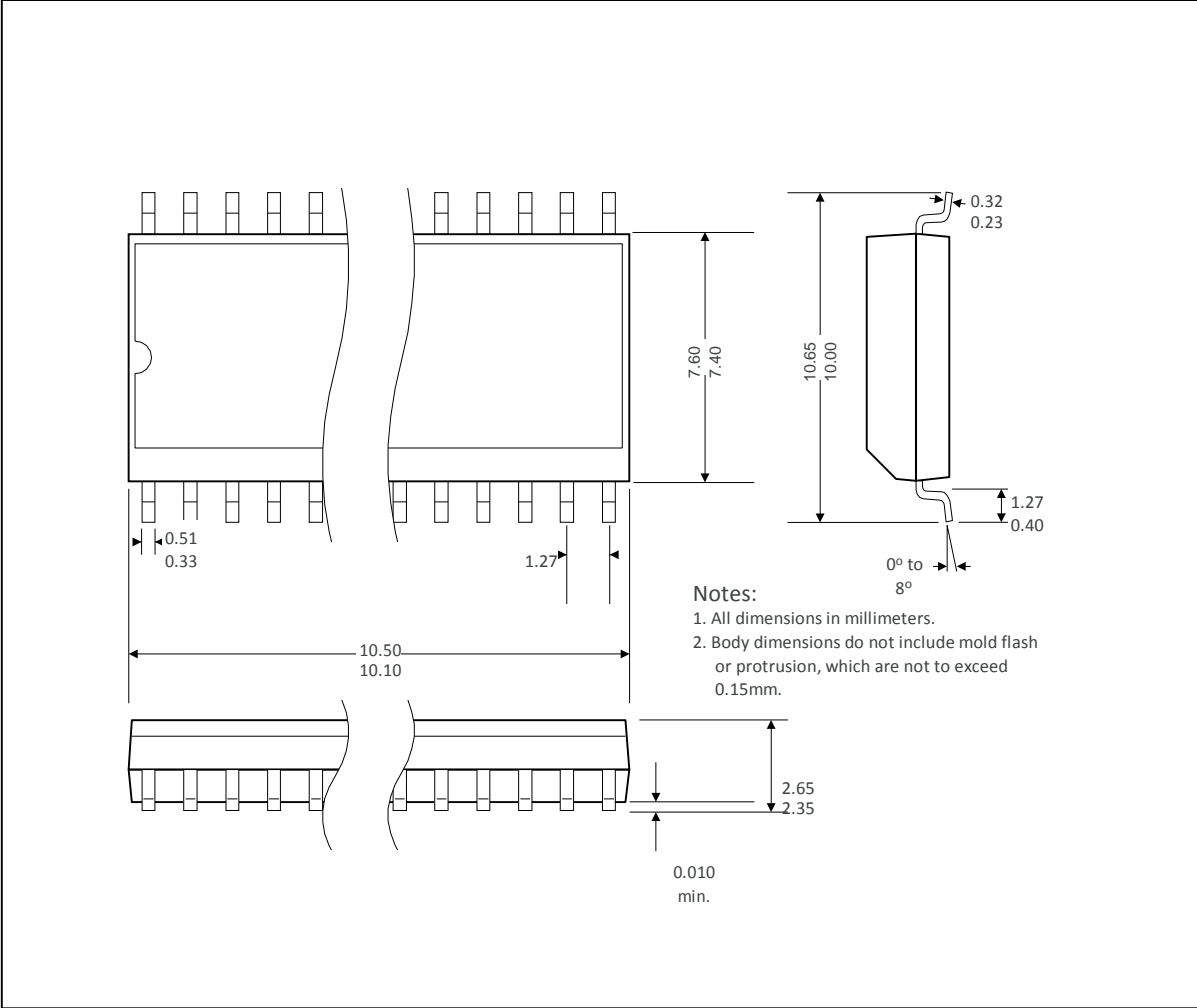

14. Standard information regarding manufacturability of Melexis products with different soldering processes

Our products are classified and qualified regarding soldering technology, solderability and moisture sensitivity level according to following test methods:

Reflow Soldering SMD's (Surface Mount Devices)

- IPC/JEDEC J-STD-020
Moisture/Reflow Sensitivity Classification for Nonhermetic Solid State Surface Mount Devices (classification reflow profiles according to table 5-2)
- EIA/JEDEC JESD22-A113
Preconditioning of Nonhermetic Surface Mount Devices Prior to Reliability Testing (reflow profiles according to table 2)

Wave Soldering SMD's (Surface Mount Devices) and THD's (Through Hole Devices)

- EN60749-20
Resistance of plastic- encapsulated SMD's to combined effect of moisture and soldering heat
- EIA/JEDEC JESD22-B106 and EN60749-15
Resistance to soldering temperature for through-hole mounted devices

Iron Soldering THD's (Through Hole Devices)

- EN60749-15
Resistance to soldering temperature for through-hole mounted devices

Solderability SMD's (Surface Mount Devices) and THD's (Through Hole Devices)

- EIA/JEDEC JESD22-B102 and EN60749-21
Solderability

For all soldering technologies deviating from above mentioned standard conditions (regarding peak temperature, temperature gradient, temperature profile etc) additional classification and qualification tests have to be agreed upon with Melexis.

The application of Wave Soldering for SMD's is allowed only after consulting Melexis regarding assurance of adhesive strength between device and board.

Melexis is contributing to global environmental conservation by promoting **lead free** solutions. For more information on qualifications of **RoHS** compliant products (RoHS = European directive on the Restriction Of the use of certain Hazardous Substances) please visit the quality page on our website:

<http://www.melexis.com/quality.aspx>

15. Contact

For the latest version of this document, go to our website at www.melexis.com.

For additional information, please contact our Direct Sales team and get help for your specific needs:

Europe, Africa	Telephone: +32 13 67 04 95
	Email : sales_europe@melexis.com
Americas	Telephone: +1 603 223 2362
	Email : sales_usa@melexis.com
Asia	Email : sales_asia@melexis.com

16. Disclaimer

The information furnished by Melexis herein ("Information") is believed to be correct and accurate. Melexis disclaims (i) any and all liability in connection with or arising out of the furnishing, performance or use of the technical data or use of the product(s) as described herein ("Product") (ii) any and all liability, including without limitation, special, consequential or incidental damages, and (iii) any and all warranties, express, statutory, implied, or by description, including warranties of fitness for particular purpose, non-infringement and merchantability. No obligation or liability shall arise or flow out of Melexis' rendering of technical or other services.

The Information is provided "as is" and Melexis reserves the right to change the Information at any time and without notice. Therefore, before placing orders and/or prior to designing the Product into a system, users or any third party should obtain the latest version of the relevant information to verify that the information being relied upon is current.

Users or any third party must further determine the suitability of the Product for its application, including the level of reliability required and determine whether it is fit for a particular purpose.

The Information is proprietary and/or confidential information of Melexis and the use thereof or anything described by the Information does not grant, explicitly or implicitly, to any party any patent rights, licenses, or any other intellectual property rights.

This document as well as the Product(s) may be subject to export control regulations. Please be aware that export might require a prior authorization from competent authorities.

The Product(s) are intended for use in normal commercial applications. Unless otherwise agreed upon in writing, the Product(s) are not designed, authorized or warranted to be suitable in applications requiring extended temperature range and/or unusual environmental requirements. High reliability applications, such as medical life-support or life-sustaining equipment are specifically not recommended by Melexis.

The Product(s) may not be used for the following applications subject to export control regulations: the development, production, processing, operation, maintenance, storage, recognition or proliferation of 1) chemical, biological or nuclear weapons, or for the development, production, maintenance or storage of missiles for such weapons; 2) civil firearms, including spare parts or ammunition for such arms; 3) defense related products, or other material for military use or for law enforcement; 4) any applications that, alone or in combination with other goods, substances or organisms could cause serious harm to persons or goods and that can be used as a means of violence in an armed conflict or any similar violent situation.

The Products sold by Melexis are subject to the terms and conditions as specified in the Terms of Sale, which can be found at <https://www.melexis.com/en/legal/terms-and-conditions>.

This document supersedes and replaces all prior information regarding the Product(s) and/or previous versions of this document.

Melexis NV © - No part of this document may be reproduced without the prior written consent of Melexis. (2016)

ISO/TS 16949 and ISO14001 Certified

X-ON Electronics

Largest Supplier of Electrical and Electronic Components

Click to view similar products for [Sensor Interface](#) category:

Click to view products by [Melexis](#) manufacturer:

Other Similar products are found below :

[ZSC31150GEG1-T](#) [ZSSC4161BE2W](#) [MCZ33784EF](#) [FM-254-8-P](#) [LM1815MX/NOPB](#) [FM-213-4-P](#) [MAX31850KATB+](#) [FM-215-8](#) [FM-253-4-P](#) [AS8510-ASSM](#) [AD598AD](#) [AD598JRZ](#) [AD598SD/883B](#) [743478D](#) [AD698APZ](#) [AD698SQ](#) [ADA4558WHCPZ-R7](#) [ADPD4000BCBZR7](#) [ADPD4001BCBZR7](#) [DRV401AIDWPR](#) [MAX9921AUB/V+T](#) [MAX1358BETL+](#) [MAX14827ATG+](#) [MAX14832ETB+](#) [MAX14829ATG+](#) [MAX14838GTC+T](#) [MAX22520GWP+](#) [MAX31911AUI+](#) [RE46C803SS20](#) [MAX14826GTG+](#) [MAX1452AAE+](#) [MAX31855SASA+T](#) [MAX31855EASA+](#) [MAX31855SASA+](#) [MAX31855TASA+](#) [MAX31855KASA+T](#) [MAX31855NASA+](#) [MAX35102ETJ+](#) [MAX35103EHJ+](#) [MAX6682MUA+](#) [MAX86171ENI+](#) [MAX9921AUB+](#) [MAX9924UAUB+T](#) [MAX9925AUB+](#) [MAX9927AEE+](#) [MAX1454AUE/V+](#) [MAX1454AUE+](#) [RE46C800SS20](#) [SSC7102-GQ-AB2](#) [MAX6675ISA+](#)