

## 1. Features and Benefits

- Suited cost optimized sensors: gain and offset correction by programmable coefficients
- Higher order temperature compensation provided for both gain and offset
- External or internal temperature sensor for compensation of temperature errors
- Over-voltage protection
- Fault detection and clamping levels
- Ratio-metric output: 0 to 5V
- Single Pin Digital Programming
- Fully analog signal path
- RoHS compliant

## 2. Application Examples

- Pressure transducers, strain gauges, accelerometers, position sensors, etc.
- Steering systems (e.g. torque sensors)
- Safety restraints systems (e.g. seat occupant detection)
- Braking systems (e.g. ABS, force)
- Comfort systems (e.g. air conditioning)
- Engine management (e.g. injection)
- Any bridge type sensor

## 3. Ordering information

Product Code	Temperature Code	Package Code	Option Code	Packing Form Code
MLX90320	L	FR	BBA-000	RE
MLX90320	L	FR	BBA-000	TU

### Legend:

Temperature Code: L for Temperature Range -40°C to 150°C  
 Package Code: FR for SSOP 209 mil  
 Packing Form: RE for Reel, TU for Tube  
 Ordering example: MLX90320LFR-BBA-000-RE

## 4. Functional Diagram

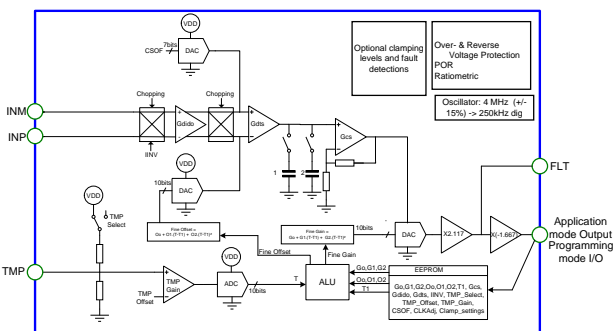

## 5. General Description

The MLX90320 covers the most typical resistive type of Wheatstone bridge applications for use in an automotive environment. It is a monolithic silicon analog sensor interface that converts small changes in resistors, configured in a full

Wheatstone bridge on a sensing element, to large output voltage variations.

The signal conditioning includes gain adjustment, offset control and second order temperature compensation in order to accommodate variations of the different resistive sensing elements. Compensation values are stored in EEPROM and can be reprogrammed with an interface circuit and provided software. The MLX90320 is programmed with a single wire serial interface through the output pin.

The user can specify on chip clamping levels thus creating fault detection bands. By intercepting various fault modes the MLX90320 is able to inform about the reliability of its analog output signal.

## Contents

<b>1. Features and Benefits</b> .....	<b>1</b>
<b>2. Application Examples</b> .....	<b>1</b>
<b>3. Ordering information</b> .....	<b>1</b>
<b>4. Functional Diagram</b> .....	<b>1</b>
<b>5. General Description</b> .....	<b>1</b>
<b>6. Maximum ratings</b> .....	<b>4</b>
<b>7. Pad definitions and descriptions</b> .....	<b>4</b>
<b>8. MLX90320 General Specifications</b> .....	<b>6</b>
<b>9. Detailed Description</b> .....	<b>11</b>
9.1. EEPROM.....	12
9.2. The programmable clock.....	12
9.3. The temperature chain.....	13
9.4. The sensor signal chain.....	14
9.4.1. The Gain calibration of the sensor signal chain. ....	15
9.4.2. The Offset calibration of the sensor signal chain.....	16
9.4.3. The output clamping levels .....	18
9.4.4. The Faults detection .....	18
9.5. Programming the MLX90320 through the output pin.....	20
9.5.1. Overview .....	20
9.5.2. Communication Initialization Request.....	20
9.5.3. Communication Request.....	21
9.5.4. Bit format .....	21
9.5.5. Commands .....	22
<b>10. Unique Features</b> .....	<b>24</b>
<b>11. Typical applications circuits</b> .....	<b>25</b>
11.1. Ratio-metric mode with use of external temperature sensor. ....	25
11.2. Ratio-metric mode without use of external temperature sensor.....	26
11.3. Non Ratio-metric mode with use of external temperature sensor. ....	26
11.4. Non Ratio-metric mode without use of external temperature sensor.....	27
<b>12. EEPROM Contents</b> .....	<b>27</b>

# MLX90320

Automotive Sensor Interface

13. Standard information regarding manufacturability of Melexis products with different soldering processes.....	31
14. Package Information.....	32
15. Contact.....	34
16. Disclaimer.....	34

## 6. Maximum ratings

Parameter	Min	Max	Units	Comments
Supply Voltage, $V_{DD}$	-14.5	16	V	No latch-up or damage. Rise time(10 to 90%) $t_r \geq 1\mu s$ .
Supply Voltage, $V_{DD} - V_{SS}$	4.5	5.5	V	Operating within specifications
Output current limit	-50	-9	mA	Short to $V_{DD}$
	9	50	mA	Short to Gnd
Operating Temperature Range, $T_{environment}$	-40	150	°C	
Storage Temperature Range	-50	150	°C	
Programming Temperature Range	-40	125	°C	
Package Thermal Resistance		130	°C/W	
ESD Sensitivity	2		kV	HBM. CDF - AEC - Q100-002
Latch-up withstand				CDF - AEC - Q100-004; $V_{DD} = 5.5V$

Table 1: Absolute maximum ratings

Exceeding the absolute maximum ratings may cause permanent damage. Exposure to absolute-maximum-rated conditions for extended periods may affect device reliability.

## 7. Pad definitions and descriptions

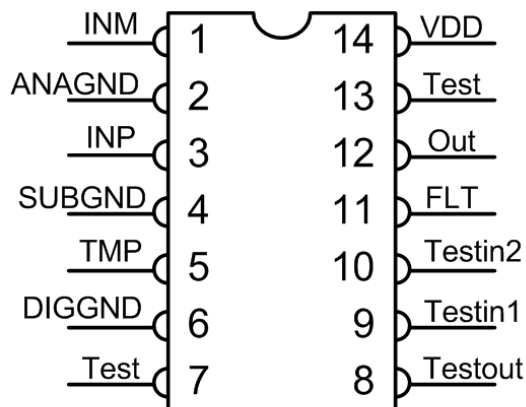

Package Pin Nr	Short Name	Dir	Type	Function / Description
1	INM	IN	Analog	Bridge Sensor Negative
2	ANAGND	gnd		Analog Ground
3	INP	IN	Analog	Bridge Sensor Positive
4	SUB	gnd		Substrate Ground
5	TMP	IN	Temp	External Temperature Sensor (Resistor to supply)
6	DIGGND	gnd		Digital Ground
7	Test	NC		On module to ground.
8	TESTOUT	OUT	Test	Test Output. On module to ground
9	TESTIN1	IN	Test	Test Input 1: CLKEXT, TEST (3 level)
10	TESTIN2	IN	Test	Test Input 2: DATAIN, SCAN (3 level)
11	FLT	OUT	Analog	Filter pin
12	OUT	BI	Analog	Analog output and communication pin
13	Test	NC		On module to ground
14	VDD	power	Supply	Supply

*Table 2: Pin description MLX90320*

## 8. MLX90320 General Specifications

DC Operating Parameters  $T_A = -40^{\circ}\text{C}$  to  $150^{\circ}\text{C}$  (guaranteed through automotive qualification standards),  $V_{DD} = 5\text{V}$  (unless otherwise specified), packaged parts are fully tested during production between  $-40^{\circ}\text{C}$  and  $135^{\circ}\text{C}$ , dies are fully tested during production between  $25^{\circ}\text{C}$  and  $135^{\circ}\text{C}$ .

General Electrical Specifications						
Parameter	Symbol	Comments	Min	Typ	Max	Units
Supply Voltage	VDD		4.5		5.5	V
Supply Current	IDD	No output load, $V_{DD}=5\text{V}\pm 10\%$	4		9	mA
Output capacitive load		$10\Omega < R_{\text{SERIES}} < 10\text{ k}\Omega$	0		100	nF
Output resistive load		To reach 5%VDD to 95%VDD	2.8 See remark 1		See remark 2	k $\Omega$
Output current capability			$\pm 1.7$			mA
Output short circuit current		$V_{DD}=5\text{V}\pm 10\%$			$\pm 50$	mA
Digital output current			$\pm 2$		$\pm 5$	mA
$V_{DD}$ line inductance			0		22	$\mu\text{H}$

Clamping Levels Specifications						
Parameter	Symbol	Comments	Min	Typ	Max	Units
Clamping output low 0	Clamp low min	See paragraph 6.4.3 for detailed explanation	2	4 See remark 3	6	$\%V_{DD}$
Clamping output low 1		7 other low clamping levels with a clamp level variation of $1.3\%V_{DD}$ for each		Clamp low min + $1.3\%V_{DD}$		$\%V_{DD}$

Clamping output low n		n = [0..7]		Clamp low min + n*1.3%V <sub>DD</sub>		%V <sub>DD</sub>
Clamping output high 0	Clamp high max	See paragraph 6.4.3 for detailed explanation	94	96 See remark 3	98	%V <sub>DD</sub>
Clamping output high1		7 other high clamping levels with a clamp level variation of 1.3%V <sub>DD</sub> for each		Clamp high max – 1.3%V <sub>DD</sub>		%V <sub>DD</sub>
Clamping output high n		n = [0..7]		Clamp high max – n*1.3%V <sub>DD</sub>		%V <sub>DD</sub>

### Diagnostic Limits Specifications

Parameter	Symbol	Comments	Min	Typ	Max	Units
Low diagnostic output					4	%V <sub>DD</sub>
High diagnostic output			96			%V <sub>DD</sub>

### Signal path general Specifications

Parameter	Symbol	Comments	Min	Typ	Max	Units
Overall typical gain		See table 3 below for an overview	12.7		442	V/V
Coarse gain	G <sub>dido</sub>	1bit programmable	3.25 (G <sub>dido</sub> = 0) 13 (G <sub>dido</sub> = 1)			V/V
	G <sub>dts</sub>	1bit programmable	1.994 (G <sub>dts</sub> = 0) 4.96 (G <sub>dts</sub> = 1)			V/V

	$G_{cs}$	1bit programmable	1.238 ( $G_{cs} = 0$ ) 1.934 ( $G_{cs} = 1$ )			V/V
Typical fine gain	Fgain	10 bit programmable	0.446		0.99	V/V
Typical sensor output span that can be accommodated to achieve 4V output span		Without an optimal compensation of the sensitivity temperature drift (i.e. with the fine gain equal to one of the extreme range values)	1.8		63	mV/ $V_{supply}$
Typical sensor output span that can be accommodated to achieve 4V output span		With an optimal compensation of the sensitivity temperature drift (i.e. with the fine gain equal to the middle range value)	2.5		40	mV/ $V_{supply}$
Typical sensor offset that can be compensated		Depends on gain settings and desired output offset voltage. See Table 3 below for an overview.			97.2	mV/ $V_{supply}$
Output Offset programmable			10		90	% $V_{DD}$
Output Offset resolution					0.1	% $V_{DD}$
Overall non linearity		Best fit value			$\pm 0.1$	% $V_{DD}$



Wake-up time at power up		MLX90320 operational, in spec.	0		10	ms
Output noise		47nF FLT capacitance with maximum gain			5	mV <sub>rms</sub>
Response time		Set by an external capacitor			0.1	ms

Remark 1: For a reduced temperature range of -40°C to 135°C, the MLX90320 is able to cover the output voltage range from 5%Vdd till 95%Vdd for all loads higher than 2kOhm.

Remark 2: When using a pull up load, during a fault condition, a leakage current of 20µA maximum will flow in the load. The voltage drop due to this leakage current will limit the achievable high voltage. To be sure that the high fault band is always achieved during a fault condition a load smaller than  $4\%V_{dd} / 20\mu A = 10k\Omega$  has to be used.

Remark 3: Each clamping level itself has an inaccuracy of +/-2%Vdd maximum. But the 1.3%Vdd step between each level is very accurate. By selecting the clamping level closest to the desired level an accuracy of +/-0.65%Vdd can be reached. To be sure that there is never an overlap between the fault band and the normal band it is better to keep at least a 1%Vdd gap between the clamping level and the fault band (i.e. the maximum clamping level should be  $\leq 95\%V_{dd}$  and the minimum should be  $\geq 5\%V_{dd}$ ).

Table 3

$G_{\text{audio}}$	$G_{\text{dts}}$	$G_{\text{cs}}$	Fine Gain V/V	Typical Total Gain V/V	Sensor span in order to achieve 4V output span (mV) Remark 4	Typical total sensor offset that can be compensated to achieve 0.5V as MLX90320 output offset (mV)	Typical total sensor offset that can be compensated to achieve 4.5V as MLX90320 output offset (mV)
0	0	0	0.446	12.7		-306.7	171.1
0	0	0	0.99	28.4	196.1	-328.3	-187.3
0	0	1	0.446	19.9		-320.8	157.1
0	0	1	0.99	44.3	125.2	-334.6	143.3
0	1	0	0.446	31.8		-329.0	147.9
0	1	0	0.99	70.9	78.3	-338.6	139.3
0	1	1	0.446	49.6		-335.6	142.3
0	1	1	0.99	110.8	50.2	-341.1	136.8
1	0	0	0.446	50.7		-76.9	42.9
1	0	0	0.99	113.2	49.1	-82.3	37.5
1	0	1	0.446	79.2		-80.4	39.4
1	0	1	0.99	176.8	31.5	-83.9	36.0
1	1	0	0.446	126.7		-82.7	37.1
1	1	0	0.99	282.9	19.7	-84.9	34.9
1	1	1	0.446	197.9		-84.2	35.7
1	1	1	0.99	441.8	12.6	-85.5	34.3
							8.0
							-119.3
							-244.3
							-204.1
							-282.2
							-255.0
							-305.0
							2.0
							-47.0
							-29.9
							-61.3
							-51.2
							-70.8
							-63.9
							-76.5

Remark 4: For the best compensation of the sensor sensitivity drift with temperature, the typical sensor output span needed to reach the 4V output span must be calculated for a fine gain in the middle of its range (i.e. 0.72 V/V)

## 9. Detailed Description

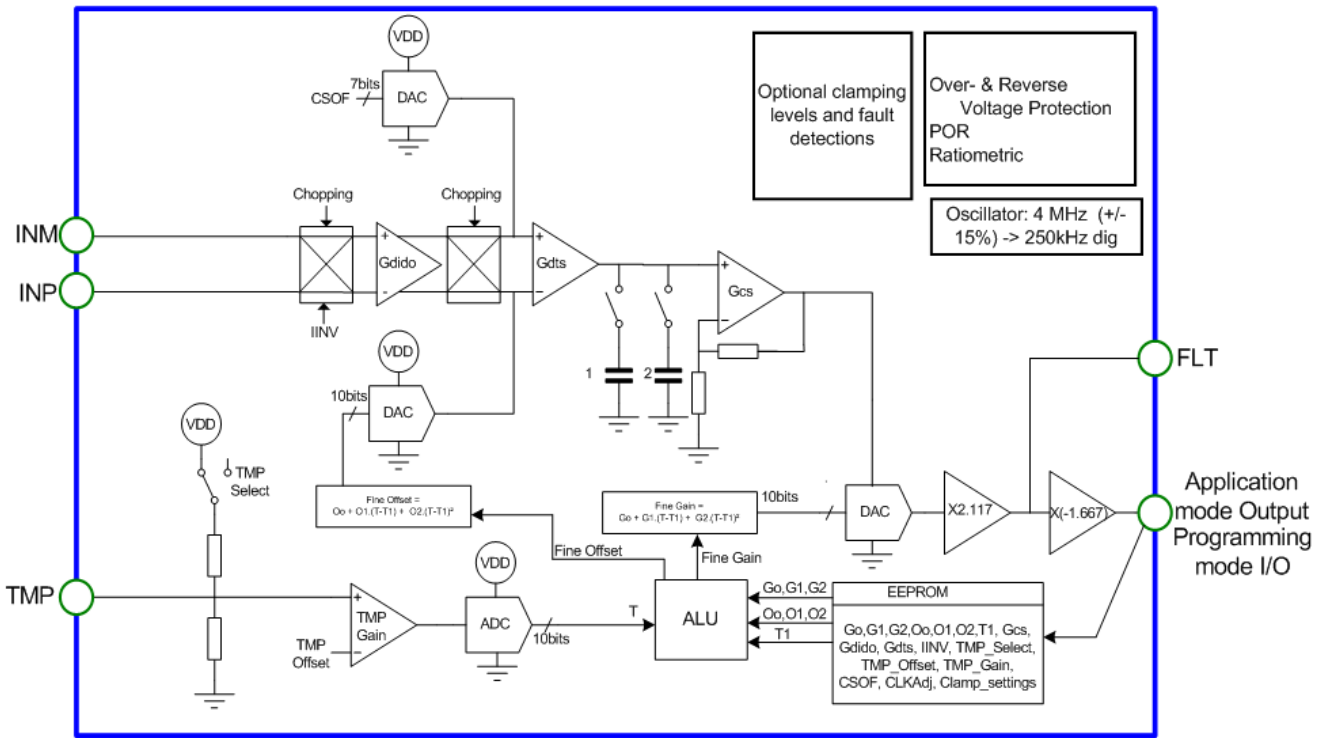

Figure 1: General block diagram of the MLX90320

The MLX90320 can be used with almost any type of resistive bridge sensor without the need of any additional signal conditioning.

The differential input signal is offset compensated and amplified to achieve the desired output voltage. With a coarse gain calibration the MLX90320 can easily accommodate sensor output spans in the 1.8mV/V to 63mV/V range to achieve 4 V output span. Sensor output offsets until 97.2mV/V (depending on the sensor output span and on the desired output offset, see table 3 for the details) can be compensated with the coarse offset calibration to achieve an output offset in the 0.5V to 4.5V range. Figure 2 shows two typical output characteristics that can be obtained with the MLX90320. The option of swapping the inputs by setting one bit in EEPROM and the wide variation of the output offset with the coarse offset calibration allows calibrating a decreasing output characteristic as shown in figure 2. All output characteristics between those described in figure 2 can be achieved for a wide range of sensor output spans and offsets.

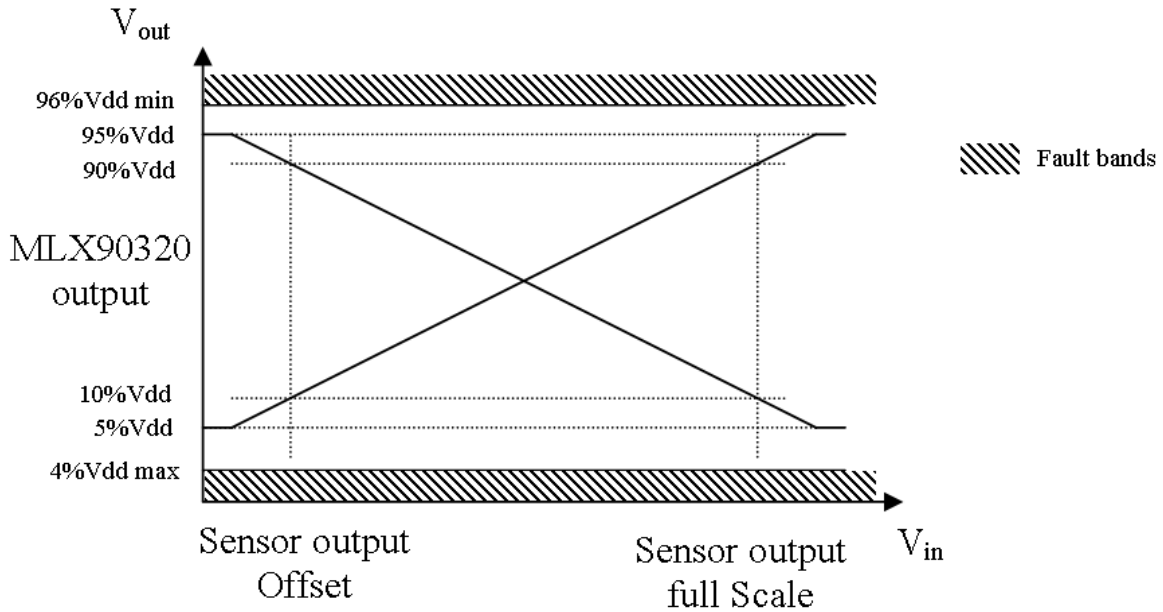

Figure 2: Two typical MLX90320 output characteristics obtained after calibration

Besides the coarse gain and offset adjustment, the MLX90320 can accurately adjust the output span and offset to the desired values by calibrating a fine gain and a fine offset 10 bits DAC. This fine calibration allows also compensating second order temperature drifts of the sensor sensitivity and offset. An accurate temperature chain gives the information needed to compensate this temperature drift. The user has the possibility of selecting between an internal and an external temperature sensor by setting one bit in EEPROM.

What follows is the description of the different features of the MLX90320. For each feature the different calibration parameters associated will be explained and their address in the EEPROM will be given. Only typical values are used in this section.

## 9.1. EEPROM

The EEPROM is a 64 x 5 bits memory. A detailed description of the EEPROM memory address map is given in the paragraph 9. So each EEPROM address contains 4 calibration bits and one parity bit. The sum of the '1's of the five bits must be '1'. That means that when data is '0000' the parity must be '1' (other examples: '0100' parity is '0'; '1100' parity is '1'; '1111' parity is '1').

## 9.2. The programmable clock.

The CLKADJ[3:0] bits are stored in address 3 of the EEPROM. These bits are used to program the oscillator. If CLKADJ[3:0] = 1111, the oscillator runs at the highest frequency. If CLKADJ[3:0] = 0000, the oscillator runs at the slowest frequency. This calibration is required to calibrate the 4 MHz oscillator within +/-15% accuracy. A bad oscillator calibration may cause malfunction of the communication protocol thus it is only factory set.

## 9.3. The temperature chain.

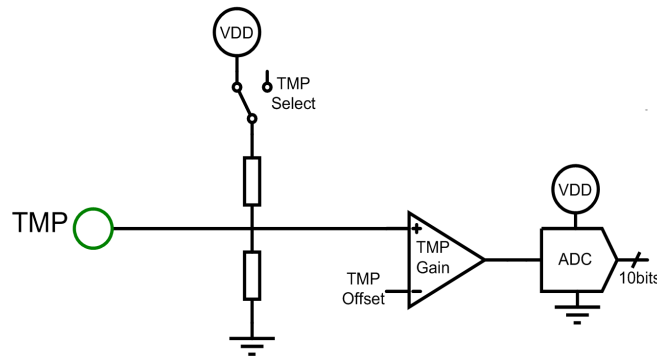

Figure 3: The temperature chain

The temperature chain is composed of the temperature sensor, an amplifier with programmable gain and offset and a SAR ADC.

The user can choose between an internal or an external temperature sensor. By setting the bit `TMP_Select` to 1 (EEPROM address 23) the internal temperature sensor is chosen and the `TMP` pin has to be left floating in application mode. If `TMP_Select` is 0 the external temperature sensor is chosen and an external resistor has to be connected between the supply voltage and the `TMP` pin. The MLX90320 should be used with an external temperature sensor in applications where the temperature surrounding the customer sensor is different from the temperature surrounding the MLX90320. An example of external resistor that could be used in those specific applications is given in paragraph 8.

As the sensitivity and the offset of the temperature sensor can vary a lot from part to part, the temperature chain must be calibrated. For that reason the amplifier gain is three bits programmable (`TMP_GAIN` bits stored in EEPROM address 31). These three bits are used to calibrate the sensitivity of the temperature chain. The amplifier offset is five bits programmable (`TMP_OFFSET` bits stored in EEPROM address 23 and 27) and compensates the offset of the temperature sensor. After calibration the output of the temperature chain amplifier must be within the input range of the SAR ADC for the entire application temperature range.

When the calibration of the temperature chain is over, the 10 bits room temperature `T1` can be stored in the EEPROM (address 0 to 3 for the `T1` value used to calculate the fine gain and address 16 to 18 for `T1` value used to calculate the fine offset) and it will be used for the sensor signal chain offset and sensitivity temperature drift compensation.

Remark: Refer to the document `AN_MLX90320.pdf` for detailed information on how to calibrate the temperature chain and the sensor signal chain.

## 9.4. The sensor signal chain.

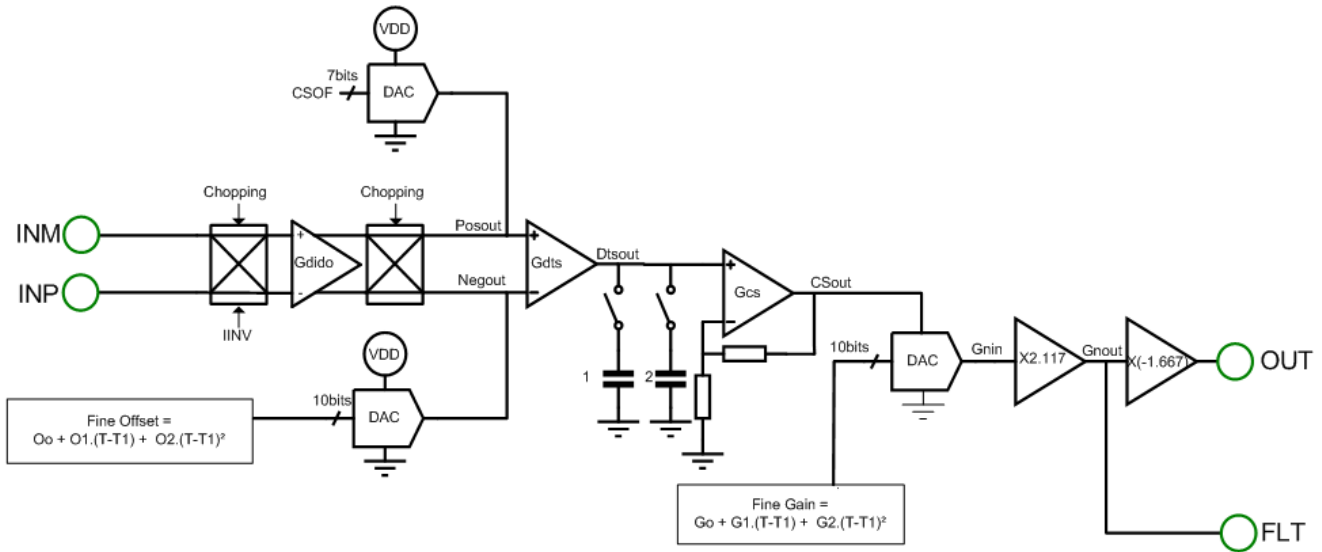

Figure 4: The sensor signal chain

The input of the sensor signal chain is a differential voltage INP-INM. The differential inputs can be inverted by setting the IINV bit (EEPROM address 7). This is done by a 180° phase shift of the chopping signal. This allows calibrating a decreasing output characteristic instead of an increasing one as shows Figure 2.

A dual input dual output 1 bit gain programmable amplifier (Gdido) is the first amplifier stage of the sensor signal chain. The use of noise and offset reduction techniques like chopping and sample and hold makes the contribution of the on-chip noise, offset and offset drift negligible compared to the same imperfections from the external sensor. A dual input single output 1 bit programmable gain amplifier (Gdts) and a 1 bit programmable gain charge summing amplifier (Gcs) completes the programmable coarse gain of the sensor signal chain. Thanks to the wide programmable coarse gain range, the MLX90320 can accommodate wide sensor output spans.

A coarse and fine sensor offset compensation is done at the inputs of the dual to single amplifier (Gdts). A fine gain DAC allows calibrating accurately the output span. A wide range of sensor offsets can be compensated with the coarse offset calibration while the desired output offset can be achieved accurately with the fine offset calibration. The fine gain and offset calibration allows compensating a second order temperature drift of the sensor sensitivity and offset. An external capacitor connected to the FLT pin sets the bandwidth of the MLX90320.

The global equations of the sensor signal chain are given below:

$$POS_{OUT} - NEG_{OUT} = \begin{cases} G_{DIDO} \times (INP - INM), & \text{if } \_IINV = 0 \\ G_{DIDO} \times (INM - INP), & \text{if } \_IINV = 1 \end{cases}$$

$$AGND = 0.699 \times V_{DD}$$

$$Dts_{OUT} = -G_{DTS} \times (POS_{OUT} - NEG_{OUT}) + \frac{G_{DTS}}{3} \times (FN_{OFF} - CS_{OFF}) + AGND$$

$$CS_{OUT} = G_{CS} \times (Dts_{OUT} - AGND) + AGND$$

$$Gn_{IN} = FN_{GAIN} \times (CS_{OUT} - AGND) + AGND$$

$$Gn_{OUT} = 2.11 \times (Gn_{IN} - AGND) + AGND$$

$$OUT = -1.668 \times Gn_{OUT} + 1.16725 \times V_{DD}$$

Explanation of the parameters used in the global equations:

- INP-INM is the differential output from the sensor
- IINV is the bit that swaps the MLX90320 inputs INP and INM
- POS<sub>out</sub>, NEG<sub>out</sub>, Dts<sub>out</sub>, CS<sub>out</sub>, Gn<sub>in</sub> and Gn<sub>out</sub> are MLX90320 internal nodes represented in the schematic of the sensor signal chain (fig 5)
- AGND is an analog ground dependent of the supply voltage V<sub>DD</sub>.
- G<sub>DIDO</sub>, G<sub>DTS</sub>, G<sub>CS</sub> form the sensor signal chain coarse gain programmable.
- FN<sub>OFF</sub> and CS<sub>OFF</sub> are respectively the sensor signal chain fine and coarse offset programmable.
- FN<sub>GAIN</sub> is the sensor signal chain fine gain programmable.
- OUT is the application mode output of the MLX90320.

The different sensor chain calibration parameters with their range will be described in the following paragraphs.

## 9.4.1. The Gain calibration of the sensor signal chain.

Three programmable coarse gain stages allow calibrating a wide range of sensor output spans (1.8mV/V to 63mV/V range) to the desired MLX90320 output span. Amplifier DIDO is a differential input – differential output amplifier, while amplifier DTS and CS are dual-to-single-ended amplifiers giving a single ended output voltage referred to the ground.

Each one of these three amplifiers is one bit programmable:

- The DIDO gain is 3.25 or 13 depending on the value of the corresponding bit stored on the address 7 of the EEPROM.
- The DTS gain is 1.994 or 4.96 depending on the value of the corresponding bit stored on the address 7 of the EEPROM.
- The CS gain is 1.238 or 1.934 depending on the value of the corresponding bit stored on the address 7 of the EEPROM.

Besides the three programmable coarse gain stages, there is also a 10 bits programmable fine gain stage within the range 44.6% to 99%. The fine gain calibration allows an accurate adjustment of the output span. The fine gain can be calculated by the formula:

$$FN_{GAIN} = (0.446 + FNGain_{real} \times (0.99 - 0.446))$$

Equation 1

Explanation of parameters used in equation 1:

- FN<sub>GAIN</sub> is the fine gain used in the signal sensor chain.
- FNGain<sub>real</sub> is the value of the fine gain in the [0..1] range with 10 bits resolution.

The fine gain calibration allows also a second order compensation of the drift with temperature of the sensor sensitivity. The value of the fine gain is given by the formula:

$$FNGain_{real} = G_0 + G_1 \times (T - T_1) + G_2 \times (T - T_1)^2$$

Equation 2

Explanation of parameters used in equation 2:

- $T_1$  is the output of the temperature chain corresponding to the room temperature. The ADC of the temperature chain outputs 10bits but 12 bits are stored (address 0 to 2 of the EEPROM). The MSB must always be 0 and the other 11 bits are obtained from an average of the previous temperature readings. This gives more accuracy to the output of the temperature chain. The  $T_1$  value used in equation 2 is in the [0..1] range with an 11 bit resolution.
- $G_0$  is the zero order fine gain coefficient (independent from the temperature) used to adjust accurately the output span at room temperature. 12 bits are stored (address 12 to 14 of the EEPROM) but only the 10 first are used. The two MSB must be 0. The  $G_0$  value used in equation 2 is in the [0..1] range with a 10 bit resolution.
- $G_1$  is the first order fine gain coefficient used to compensate the sensor sensitivity drift with temperature. 12 bits are stored (address 8 to 10 of the EEPROM). The MSB is the sign bit (two's complement): If  $G_1[11] = 1$  then  $G_1$  is negative, if  $G_1[11] = 0$  then  $G_1$  is positive. The  $G_1$  value used in equation 2 is in the [-2..2] range with an 11 bit resolution.
- $G_2$  is the second order fine gain coefficient used to compensate the sensor sensitivity drift with temperature. 12 bits are stored (address 4 to 6 of the EEPROM). The MSB is the sign bit (two's complement): If  $G_2[11] = 1$  then  $G_2$  is negative, if  $G_2[11] = 0$  then  $G_2$  is positive. The  $G_2$  value used in equation 2 is in the [-2..2] range with an 11 bit resolution.

The ALU computes equation 2 with 12 bits but the result is truncated to 10 bits because the Gain DAC is a 10 bit DAC. When the MLX90320 is not able to compensate for the sensor sensitivity drift with temperature, the fine gain calibration parameters stored in EEPROM will lead to a  $FNG_{gain\_real}$  value out of the [0..1] range. In this case the MLX90320 will indicate an overflow in the digital calculations by putting the output voltage in a fault band. When this occurs, a reset of the chip is required to go back into the normal mode of operation. Typical total gains with the corresponding sensor offset ranges that can be compensated can be found in table 3.

## 9.4.2. The Offset calibration of the sensor signal chain.

The purpose of the 7-bit offset DAC is to be able to adjust the MLX90320 output offset anywhere in the 0.5V to 4.5V range. The voltage at the output of the coarse offset DAC can be calculated by the formula:

$$CSOff_{analog} = \left( 0.905 \times V_{DD} - \frac{CSOff_{digital}}{127} \times (0.905 \times V_{DD} - 0.06 \times V_{DD}) \right) \times \frac{V_{DD}}{5}$$

Equation 3

Explanation of parameters used in equation 1:

- ❑  $CSOff_{analog}$  is the voltage at the output of the coarse offset DAC.
- ❑  $CSOff_{digital}$  is the digital decimal value of the coarse offset (7 bits stored in address 11 and 15 of the EEPROM).

The voltage span at the output of the coarse offset DAC is large enough to allow the user to calibrate a decreasing output characteristic with for example 4.5V as output offset and 0.5V as output full scale. This output characteristic is only possible by inverting the inputs (setting the IINV bit).



Besides the programmable coarse offset, there is also a 10-bits programmable fine offset stage which allows adjusting the MLX90320 output offset with a high resolution (at least a resolution of 0.1% of the supply voltage). The voltage at the output of the fine offset DAC can be calculated by the formula:

$$FNOff_{analog} = (0.2272 \times V_{DD} + FNOff_{real} \times (0.318 \times V_{DD} - 0.2272 \times V_{DD})) \times \frac{V_{DD}}{5}$$

Equation 4

Explanation of parameters used in equation 4:

- $FNOff_{analog}$  is the voltage at the output of the fine offset DAC.
- $FNOff_{real}$  is the value of the fine offset in the [0..1] range with a 10 bit resolution.

The  $\frac{V_{DD}}{5}$  term of equation 3 and 4 is due to the ratio-metric behaviour of the fine and coarse offset DACs.

The fine offset calibration allows also a second order compensation of the temperature drift of the sensor offset. The value of the fine offset is given by the formula:

$$FNOff_{real} = O_0 + O_1 \times (T - T_1) + O_2 \times (T - T_1)^2$$

Equation 5

Explanation of parameters used in equation 5:

- $T_1$  is the output of the temperature chain corresponding to the room temperature. The ADC of the temperature chain outputs 10 bits but 12 bits are stored (address 0 to 2 of the EEPROM). The MSB must always be 0 and the other 11 bits are obtained from an averaging from the previous temperature readings. This gives more accuracy to the output of the temperature chain. The  $T_1$  value used in equation 5 is in the [0..1] range with an 11 bit resolution.
- $O_0$  is the zero order fine offset coefficient (independent from the temperature) used to compensate accurately the sensor offset at room temperature. 12 bits are stored (address 28 to 30 of the EEPROM) but only the 10 first are used. The two MSB must be 0. The  $O_0$  value used in equation 5 is in the [0..1] range with a 10 bit resolution.
- $O_1$  is the first order fine offset coefficient used to compensate the sensor offset drift with temperature. 12 bits are stored (address 24 to 26 of the EEPROM). The MSB is the sign bit (two's complement): If  $O1[11] = 1$  then  $O_1$  is negative, if  $O1[11] = 0$  then  $O_1$  is positive. The  $O_1$  value used in equation 5 is in the [-2..2] range with an 11 bit resolution.
- $O_2$  is the second order fine offset coefficient used to compensate the sensor offset drift with temperature. 12 bits are stored (address 20 to 22 of the EEPROM). The MSB is the sign bit (two's complement): If  $O2[11] = 1$  then  $O_2$  is negative, if  $O2[11] = 0$  then  $O_2$  is positive. The  $O_2$  value used in equation 5 is in the [-2..2] range with an 11 bit resolution.

The ALU computes the equation 5 with 12 bits but the result is truncated to 10 bits because the Offset DAC is a 10 bit DAC. When the MLX90320 is not able to compensate for the sensor offset drift with temperature, the fine offset calibration parameters stored in EEPROM will lead to a  $FNOff_{real}$  value out of the [0..1] range. In this case

the MLX90320 will indicate an overflow in the digital calculations by putting the output voltage in a fault band. When this occurs, a reset of the chip is required to go back into the normal mode of operation.

The MLX90320 also offers the possibility to set clamping levels to the output voltage. This allows creating fault bands necessary to detect external and internal faults.

### 9.4.3. The output clamping levels

The output voltage is in application mode limited by a 3-bit programmable low and 3-bit programmable high clamping-level. In order to set the clamping level in a high impedance node, the clamping is done at the FLT pin. The FLT pin voltage is compared with the DA-converted value of CLAMPLOW<sub>dig</sub> and CLAMPHIGH<sub>dig</sub>. If the FLT pin voltage is greater than the DA-converted value of CLAMPHIGH<sub>dig</sub>, then this last voltage is used as input of the output stage. If the FLT pin voltage is smaller than the DA-converted value of CLAMPLOW<sub>dig</sub>, then this last voltage is used as input of the output stage. The transition from in range mode to clamping mode and vice versa takes place without overshoot.

The output pin low clamping level can be calculated by the formula :

$$V_{out_{lowclamp}} = (Low_{clamp} + Clamp_{low_{dig}} \times 0.013) \times V_{DD}$$

Equation 6

Explanation of parameters used in equation 6:

- $V_{out_{lowclamp}}$  is the output pin low clamping voltage.
- $Low_{clamp}$  is the lowest clamp level and has a typical value of 4%Vdd.
- $Clamp_{low_{dig}}$  is the decimal value (range of 0 to 7) of the low clamp level stored in EEPROM at the address 19.

The output pin high clamp level can be calculated by the formula:

$$V_{out_{highclamp}} = (High_{clamp} + (Clamp_{high_{dig}} - 7) \times 0.013) \times V_{DD}$$

Equation 7

Explanation of parameters used in equation 7:

- $V_{out_{highclamp}}$  is the output pin high clamping voltage.
- $High_{clamp}$  is the highest clamp level and has a typical value of 96%Vdd.
- $Clamp_{high_{dig}}$  is the decimal value (range of 0 to 7) of the high clamp level stored in EEPROM at the address 19 and 23.

### 9.4.4. The Faults detection

As mentioned before, a reliable memory is obtained by storing each bit three times in the EEPROM and by using parity check to detect data corruption and majority voting when accessing the data. Thanks to the setting of output clamping levels, the MLX90320 output voltage goes to the fault bands to point out that a fault occurred and that the output signal is unreliable. The MLX90320 contains circuitry which detects and diagnoses the following faults with the loads as described and specified in and under the conditions of paragraph 5:

## Internal faults

The MLX90320 will detect a Fault condition when INP and/or INM have a level outside of the 1.5 to 3.5 Volt range (with 5 Volt supply). The MLX90320 will also detect the following faults:

- INP and/or INM open
- Sensing element supply open
- Short-circuit of INP and/or INM with VDD
- Short-circuit of INP and/or INM with GND
- Short-circuit of FLT with VDD or GND
- EEPROM parity error

When a short-circuit of FLT with VDD or GND occurs the output goes to the fault band. For all other internal faults the output goes to the low fault band.

## External faults

### Short-circuit

- Output with VDD
- Output with GND
- Output with Vbat

### Open circuit

- VDD open
- GND open

In all of these above mentioned fault cases, the IC will generate an output within either of the diagnostic bands. If the ground broken wire detection is required the load has to be a pull up resistor with a typical value of 2,8kOhm that can be placed at the 90320 side or at the ECU side.

The MLX90320 goes also to fault mode when there is an overflow in the digital calculation of the fine offset or fine gain compensation.

The MLX90320 must survive the following reversed contacts but the output does not go to the fault bands.

- Reverse polarity
- Reverse battery polarity
- Output reversed with GND
- Output reversed with VDD

## 9.5. Programming the MLX90320 through the output pin

Communicating with the MLX90320 only requires a limited amount of interface circuitry, software and a computer. Melexis provides a communication equipment and belonging software such that the customer is able to start communicating with the chip in a matter of minutes.

The output pin acts as analog output pin and as communication pin.

The drive stage of a class AB amplifier is connected to that pin to output analog signal.

For the communication the output will be sink/source current source.

Through a short circuit detection, the ASSP knows that the user requests the pin for communication.

### 9.5.1. Overview

When the user wants to communicate with the MLX90320, communication must be requested.

This can be achieved by short-circuiting the output pin to ground and supply level.

The ASSP detects this short and after a delay time, the same output pin turns into a half-duplex digital communication channel.

### 9.5.2. Communication Initialization Request

When a new chip is supplied with 5V, before sending a first command to this chip, a power reset of 1.5ms +/- 30% is required. For the further commands with the same chip the power reset is not needed anymore.

After a communication initialization request, a delay of at least 10msec has to be taken before sending a communication request.

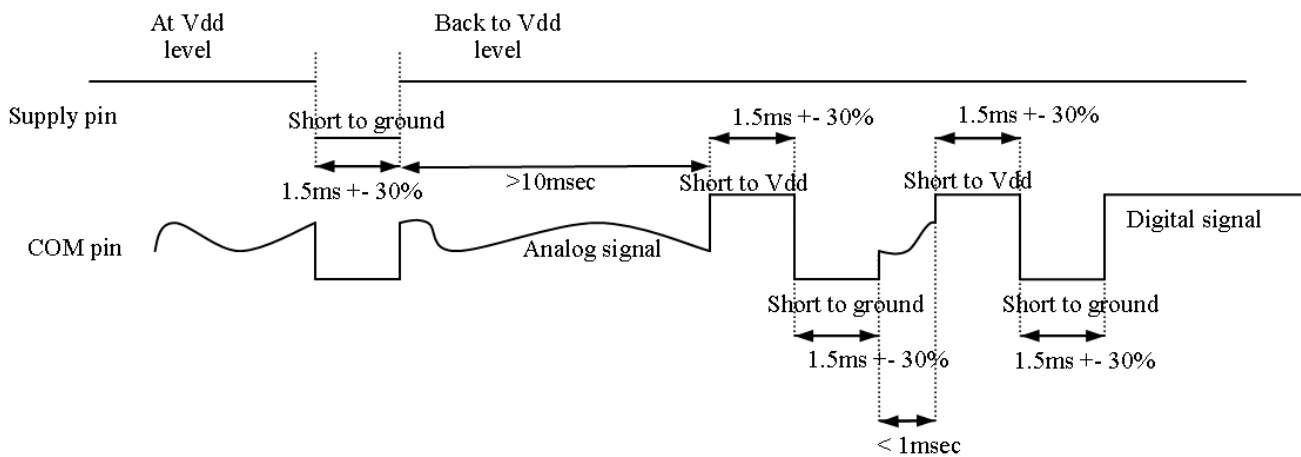

## 9.5.3. Communication Request

### 1) Pattern to enter the communication mode

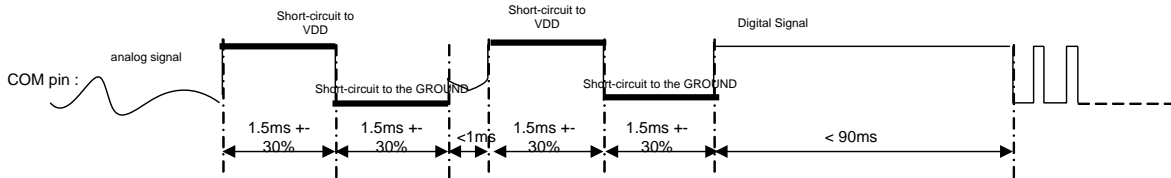

### 2) First case : the analog level is quite high :

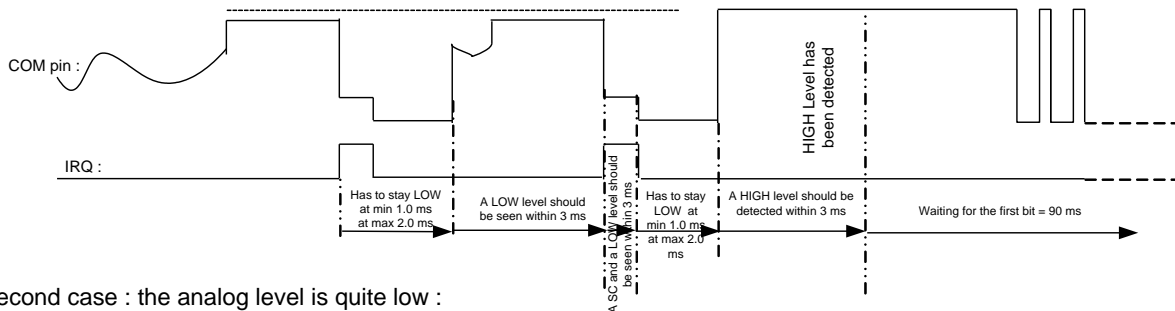

### 3) Second case : the analog level is quite low :

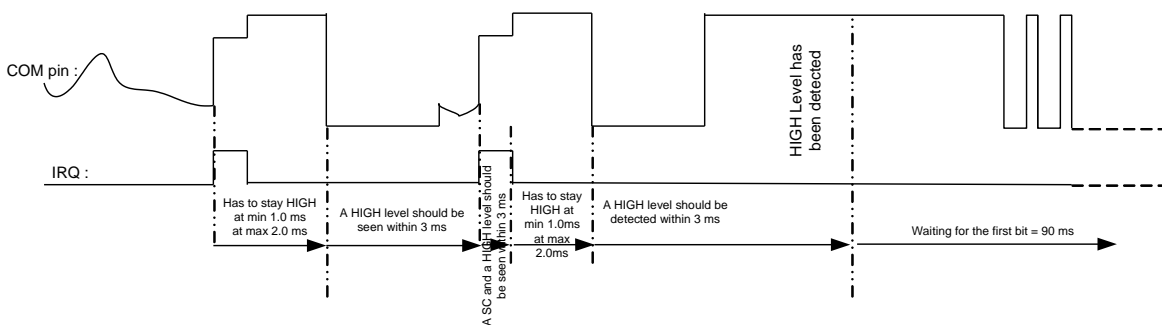

The default mode is the receive mode. The user has to send a valid command to the interface chip.

## 9.5.4. Bit format

The bit is coded into a pulse width modulated format (PWM).

PWM format has no need for message frame synchronization. This has the advantage that the receive speed can differ from the transmit speed. There is no configuration needed, the receiver can work with various bit rates.

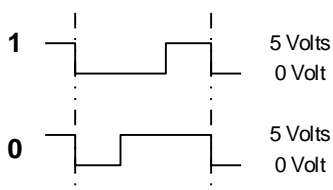

A valid bit always starts with a falling edge. This means that after making a communication request by shorting to ground, the user must reset the output line to high status.

**Duty cycle:** 30 / 70% (min = 20 / 80%, max = 40 / 60%)

**Period:** (Over total clock frequency range)

Data sent by the MLX90320			Data received by the MLX90320		
Period Length (μs)			Period Length (μs)		
Minimum	Typical	Maximum	Minimum	Typical	Maximum
1	510	695	1250	1700	2250

## 9.5.5. Commands

All delays mentioned below are calculated for a typical clock-frequency of 4 MHz. The clock frequency can differ +/- 15% on each chip. The delays will vary proportionally.

### Stop communication mode

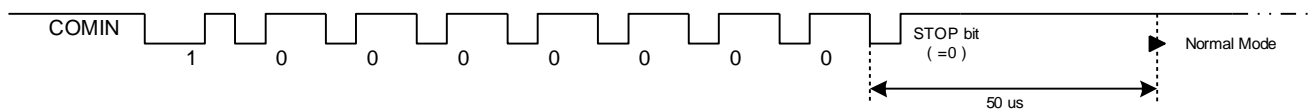

Stop the communication, ASSP goes back into normal mode. A new communication request is needed to get back into communication mode.

### Reply A5

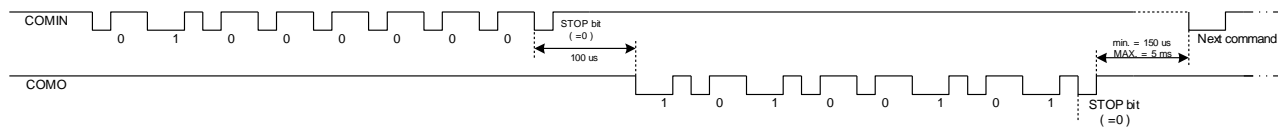

Command to see whether or not the ASSP is still in communication mode. If so, the ASSP shall respond \$A5.

### Write to EEPROM

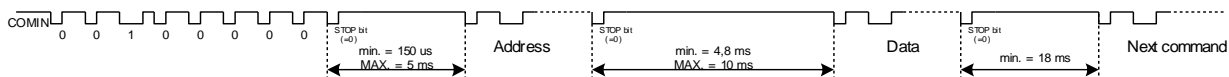

Write to a specific address. The address in the EEPROM is coded with 8 bits. As the EEPROM has 64 addresses the two first address bits should be 0. The data to store in one EEPROM address is coded with 8 bits. As each EEPROM address stores 4 calibration data bits and one parity bit, the 3 first data bits from the data byte should be 0.

### Read from EEPROM

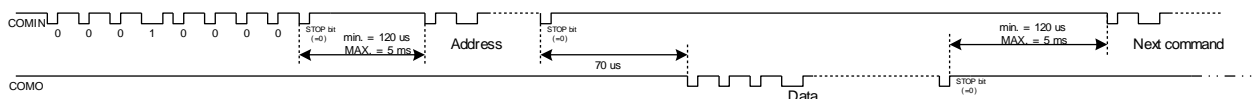

Read a specific address. The address in the EEPROM is coded with 8 bits. As the EEPROM has 64 addresses the two first address bits should be 0. A data byte is returned when reading the data from one EEPROM address but actually it contains four calibration data bits and one parity bit. So the 3 first bits read from an EEPROM address should be 0.

Read ADC value of the temperature.

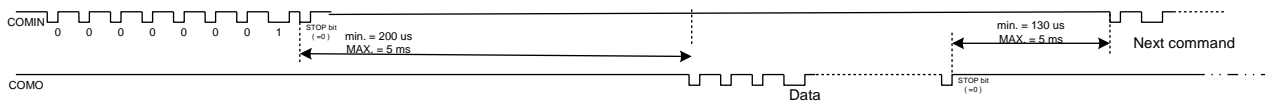

Read the digital temperature value.

The ASSP is sending back the first byte, followed a few  $\mu$ s later by the second byte.

One must readout 10bits data from these two byte.

The first byte are the 8 MSB bits of the ADC. The two highest bits of the second byte are the LSB bits of the ADC.

Lock EEPROM

To avoid unwanted rewriting of the EEPROM content in the field, it is strongly recommended to lock the EEPROM after calibration has been finished. For that purpose the 'Lock EEPROM' command can be used. The customer cannot undo the 'Lock EEPROM' command. This can only be done by Melexis using a special setup.



INM or INP connected to output

Test INP

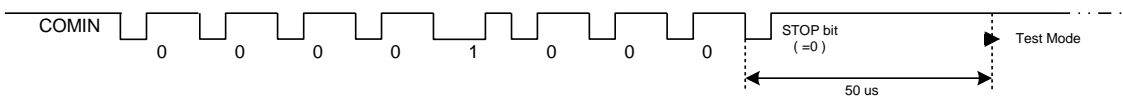

Connect INP input pin to the output. This mode can be left only by resetting the chip.

Test INM

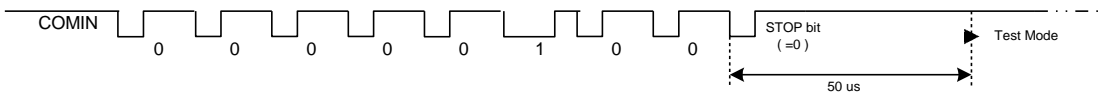

Connection INM input pin to the output. This mode can be left only by resetting the chip.

With communication one can select a mode where the INM or the INP signal is connected to the output. The chip stays in that mode until a reset is given. This can be used for failure analysis.

## 10. Unique Features

### ***Offset canceling***

The offset of amplifier DIDO is cancelled by using a chopping mechanism. Also the amplifier DTS and all sample-and-hold circuits make use of an offset canceling mechanism. This means that the contribution of the on-chip offsets and offset drifts is negligible compared to the external sensor offset and offset drift.

### ***Coarse and fine second order calibration of the sensitivity and offset.***

The MLX90320 can be calibrated to achieve 4V output span for a sensor output span in the 1.8mV/V to 63mV/V and can compensate 0.4mV/V to 97.2mV/V input offset depending on the sensor output span and on the desired MLX90320 output offset voltage. A wide range of sensor sensitivity and offset temperature drift can be compensated with the second order fine gain and offset calibration.

### ***Clamping levels and fault detection on signal***

The user can program a low and a high output voltage clamping level and thus create fault bands. Thanks to the fault bands creation, internal or external faults can be detected because they force the output voltage to go into a fault band. See paragraph 6 for more detailed explanations.

### ***EEPROM***

All the calibration data is stored three times in the EEPROM and a majority voting is used when accessing data. Parity check is used to diagnose data corruption. After all calibrations parameters were successfully written to EEPROM, the EEPROM can be locked by sending a 'Lock EEPROM' command (see paragraph 6). This is strongly recommended to avoid in application mode data corruption.



## 11. Typical applications circuits

### 11.1. Ratio-metric mode with use of external temperature sensor.

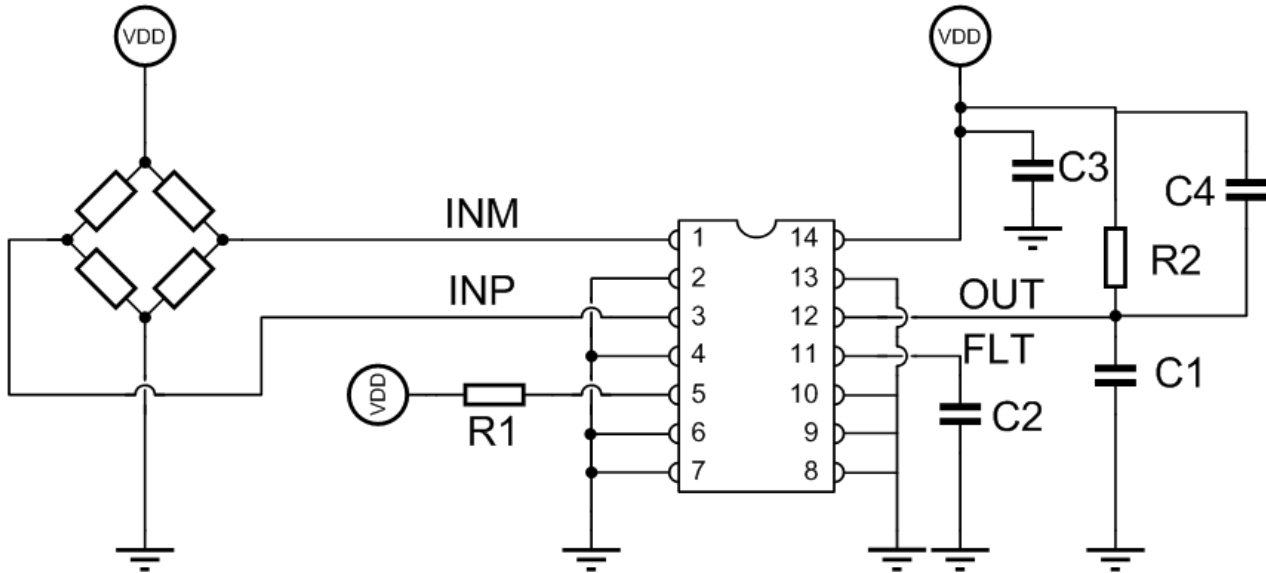

The external temperature sensor is needed for applications where the temperature surrounding the customer sensor is different from the temperature surrounding the MLX90320. In the ratio-metric application mode, to keep the accuracy, the same supply should be used for the customer sensor, the MLX90320 and an ADC that makes the digital conversion of the analog output signal.

The capacitor C1 on the output is typical 47nF. Range: 0 – 100nF.

The capacitor C2 on the FLT pin is optional. Typical value = 10nF. Range: 0 – 100nF. It is used to decrease the noise and set the bandwidth of the system.

An estimation of the MLX90320 bandwidth versus the capacitor at the FLT pin is given by the formula:

$$BW_{-3dB} = \frac{1}{2\pi \times 2k\Omega \times C_{FLT}}$$

The decoupling capacitors C3 between the supply and the ground and C4 between output and supply have a typical value of 47nF.

The external resistor R1 is placed between the TMP pin and the supply. It is used as an external temperature sensor. The external temperature sensor could be of type Panasonic, ERAS15J103V (R1 = 10k +/- 5%, TCR = 1500ppm/degC +/- 200ppm/degC) for the -40°C to 140°C temperature range. If the ground broken wire detection is required the load has to be a pull up resistor R2 with a typical value of 2.8kOhm that can be placed at the 90320 side or at the ECU side.

## 11.2. Ratio-metric mode without use of external temperature sensor.

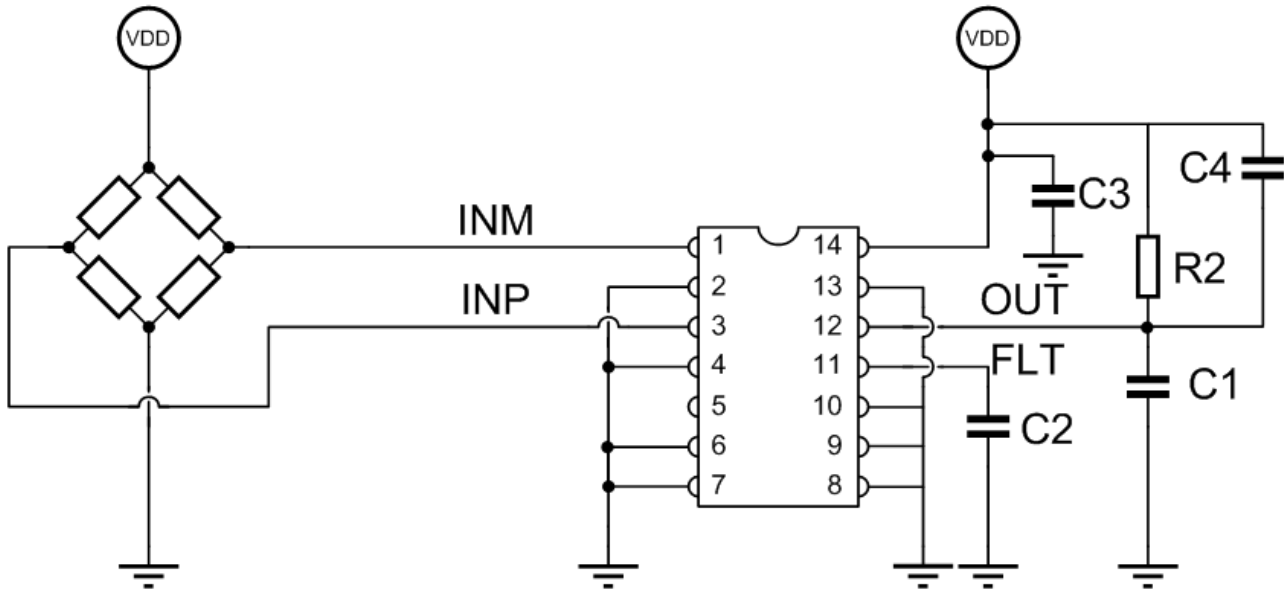

C1, C2, C3, C4 and R2 have the same values as for the ratio-metric application with use of external temperature sensor.

The internal temperature sensor can be used when the temperature surrounding the customer sensor and the MLX90320 is the same.

## 11.3. Non Ratio-metric mode with use of external temperature sensor.

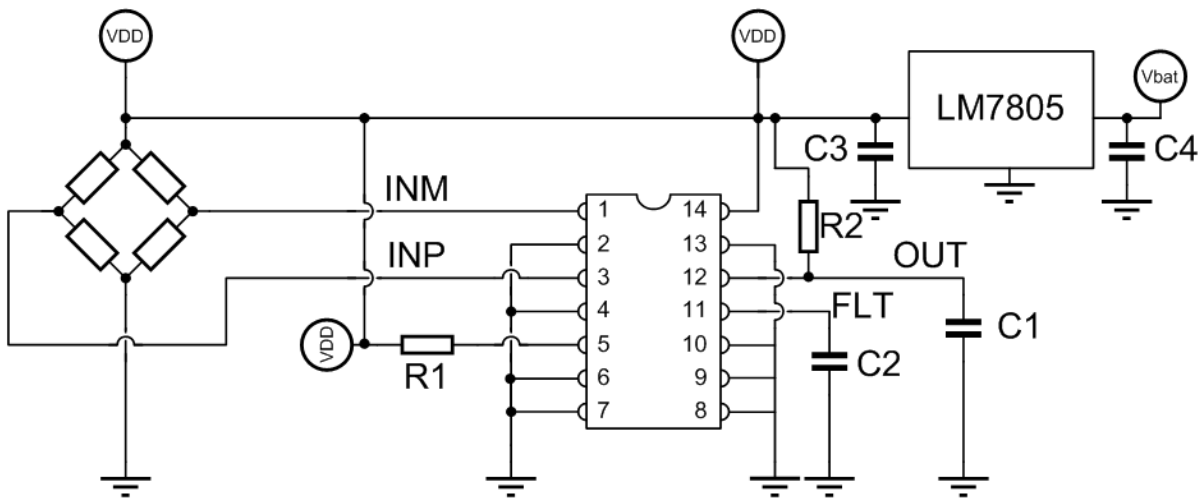

With the use of an external voltage regulator to supply the sensor, the MLX90320 as well as the ADC used to convert the analog output signal, the MLX90320 can be used in a non ratio-metric mode. An example of standard voltage regulator is the LM7805. C1, C2, R1 and R2 are the same as in the ratio-metric application mode. C4 has a typical value of 330nF and C3 of 100nF in this application mode.

## 11.4. Non Ratio-metric mode without use of external temperature sensor.

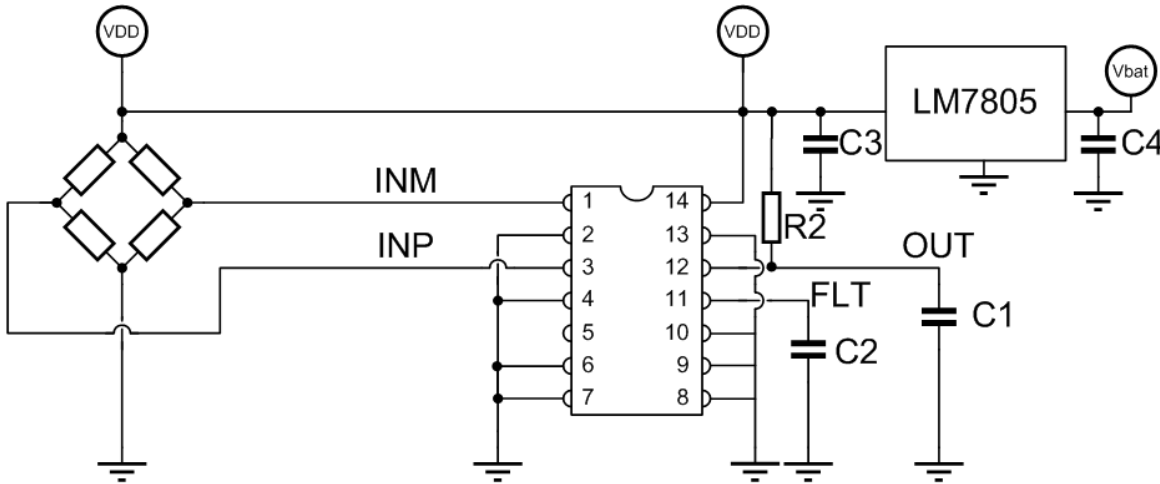

In this application mode the LM7805 generates the supply for the sensor, for the MLX90320 and for the ADC used to convert the analog output signal in a digital value. C1, C2, C3, C4 and R2 are the same as in the non ratio-metric application mode with external temperature sensor.

## 12. EEPROM Contents

Address Decimal	Bits	EEPROM content	Comments
0 to 2	0 to 3	T1 for Gain DAC	Contains the value of T1 used to calculate the fine gain in order to operate the second order compensation of the sensor span drift with temperature.
3	0 to 3	CLKADJ[3..0]	These bits are used to program the oscillator. If CLKADJ[3:0] = 1111, the oscillator runs at the highest frequency. If CLKADJ[3:0] = 0000, the oscillator runs at the slowest frequency. This calibration is required to calibrate the oscillator within +/-15% accuracy. A bad oscillator calibration may cause malfunction of the communication protocol thus it is only factory set.
4 to 6	0 to 3	G2 for Gain DAC	Contains the second order fine gain coefficient used to compensate the sensor sensitivity drift with temperature. The MSB is the sign bit (two's complement): If G2[11] = 1 then G2 is negative, if G2[11] = 0 then G2 is positive.
7	0	IINV	Bit used to invert the inputs
7	1 to 3	CG[2..0]	3 bits used to operate the coarse gain calibration. CG[2:0] = 111 means maximum gain (13*5*1.9375) and CG[2:0] = 000 means minimum gain (3.25*2*1.24).

8 to 10	0 to 3	G1 for Gain DAC	Contains the first order fine gain coefficient used to compensate the sensor sensitivity drift with temperature. The MSB is the sign bit (two's complement): If G1[11] = 1 then G1 is negative, if G1[11] = 0 then G1 is positive.
11 15	0 to 3 1 to 3	CSOF[6..0]	7 bits used to operate the coarse offset calibration.
12 to 14	0 to 3	G0 for Gain DAC	Contains the zero order fine gain coefficient (independent from the temperature) used to adjust accurately the output span at room temperature. 12 bits are stored but only the 10 first are used. The two MSB must be 0.
15	0	ClampSet	Bit used to enable(when ClampSet =1) or disable(when Clampset=0) the clamping
16 to 18	0 to 3	T1 for Offset DAC	Contains the value of T1 used to calculate the fine offset in order to operate the second order compensation of the offset drift with temperature.
19 23	0 to 3 2 and 3	CLAMP[5..0]	6 bits used for calibrating the clamping levels. CLAMP[2:0] are used for the low clamp levels (000 gives 4% at output and 111 gives 14% at output) and CLAMP[5:3] are used for the high clamp levels (000 gives 86% at output and 111 gives 96% at output).
20 to 22	0 to 3	O2 for Offset DAC	Contains the second order fine offset coefficient used to compensate the offset drift with temperature. The MSB is the sign bit (two's complement): If O2[11] = 1 then O2 is negative, if O2[11] = 0 then O2 is positive.
23 27	0 0 to 3	TMP_OFFSET[4:0]	These 5 bits are used to calibrate the offset of the external temperature sensor. If TMP_OFFSET[4:0] = 11111 then the TMP pin has the lowest voltage. If TMP_OFFSET[4:0] = 00000 then the TMP pin has the highest voltage. Goal is to calibrate in the neighbourhood of 2.5V. The internal temperature sensor offset calibration is only factory set.
23	1	TMP_SELECT	Bit used to choose between an internal or an external temperature sensor. If TMP_SELECT=1 then the internal temperature sensor is chosen else an external temperature sensor is needed.
24 to 26	0 to 3	O1 for Offset DAC	Contains the first order fine offset coefficient used to compensate the offset drift with temperature. The MSB is the sign bit (two's complement): If O1[11] = 1 then O1 is negative, if O1[11] = 0 then O1 is positive.
28 to 30	0 to 3	O0 for Offset DAC	Contains the zero order fine offset coefficient (independent from the temperature) used to compensate accurately the sensor offset at room temperature. 12 bits are stored but only the 10 first are used. The two MSB must be 0.
31	0	NOT USED	
31	1 to 3	TMP_GAIN[2:0]	These 3 bits are used to calibrate the gain of the external temperature sensor. If TMP_GAIN[2:0] = 111, the gain is the highest. If TMP_GAIN[2:0] = 000, the

			gain is the lowest. The gain is calibrated in that way that the temperature sensor output is within the ADC range. The internal temperature sensor gain calibration is only factory set.
32 to 54	0 to 4	Customer	EEPROM space for the customer use. Can be used for example to store an ID number and the date.
55 to 63	0 to 4	Melexis	EEPROM space for Melexis use only.

*Table 4 EEPROM contents description.*

Address\bits	0	1	2	3	4
0	T1[0]	T1[1]	T1[2]	T1[3]	Parity
1	T1[4]	T1[5]	T1[6]	T1[7]	Parity
2	T1[8]	T1[9]	T1[10]	T1[11]	Parity
3	CLKADJ3	CLKADJ2	CLKADJ1	CLKADJ0	Parity
4	G2[0]	G2[1]	G2[2]	G2[3]	Parity
5	G2[4]	G2[5]	G2[6]	G2[7]	Parity
6	G2[8]	G2[9]	G2[10]	G2[11]	Parity
7	IINV	CG2	CG1	CG0	Parity
8	G1[0]	G1[1]	G1[2]	G1[3]	Parity
9	G1[4]	G1[5]	G1[6]	G1[7]	Parity
10	G1[8]	G1[9]	G1[10]	G1[11]	Parity
11	CSOF3	CSOF2	CSOF1	CSOF0	Parity
12	G0[0]	G0[1]	G0[2]	G0[3]	Parity
13	G0[4]	G0[5]	G0[6]	G0[7]	Parity
14	G0[8]	G0[9]	G0[10]	G0[11]	Parity
15	ClampSet	CSOF6	CSOF5	CSOF4	Parity
16	T1[0]	T1[1]	T1[2]	T1[3]	Parity
17	T1[4]	T1[5]	T1[6]	T1[7]	Parity
18	T1[8]	T1[9]	T1[10]	T1[11]	Parity
19	Clamp3	Clamp2	Clamp1	Clamp0	Parity
20	O2[0]	O2[1]	O2[2]	O2[3]	Parity
21	O2[4]	O2[5]	O2[6]	O2[7]	Parity
22	O2[8]	O2[9]	O2[10]	O2[11]	Parity
23	TMP_offset0	TMP_select	Clamp5	Clamp4	Parity
24	O1[0]	O1[1]	O1[2]	O1[3]	Parity
25	O1[4]	O1[5]	O1[6]	O1[7]	Parity
26	O1[8]	O1[9]	O1[10]	O1[11]	Parity
27	TMP_offset4	TMP_offset3	TMP_offset2	TMP_offset1	Parity
28	O0[0]	O0[1]	O0[2]	O0[3]	Parity
29	O0[4]	O0[5]	O0[6]	O0[7]	Parity
30	O0[8]	O0[9]	O0[10]	O0[11]	Parity
31	Not used	TMP_gain2	TMP_gain1	TMP_gain0	Parity

*Table 5 EEPROM calibration data contents*

32	Cust	Cust	Cust	Cust	Cust
33	Cust	Cust	Cust	Cust	Cust
34	Cust	Cust	Cust	Cust	Cust
35	Cust	Cust	Cust	Cust	Cust
36	Cust	Cust	Cust	Cust	Cust
37	Cust	Cust	Cust	Cust	Cust
38	Cust	Cust	Cust	Cust	Cust
39	Cust	Cust	Cust	Cust	Cust
40	Cust	Cust	Cust	Cust	Cust
41	Cust	Cust	Cust	Cust	Cust
42	Cust	Cust	Cust	Cust	Cust
43	Cust	Cust	Cust	Cust	Cust
44	Cust	Cust	Cust	Cust	Cust
45	Cust	Cust	Cust	Cust	Cust
46	Cust	Cust	Cust	Cust	Cust
47	Cust	Cust	Cust	Cust	Cust
48	Cust	Cust	Cust	Cust	Cust
49	Cust	Cust	Cust	Cust	Cust
50	Cust	Cust	Cust	Cust	Cust
51	Cust	Cust	Cust	Cust	Cust
52	Cust	Cust	Cust	Cust	Cust
53	Cust	Cust	Cust	Cust	Cust
54	Cust	Cust	Cust	Cust	Cust
55	Mlx	Mlx	Mlx	Mlx	Mlx
56	Mlx	Mlx	Mlx	Mlx	Mlx
57	Mlx	Mlx	Mlx	Mlx	Mlx
58	Mlx	Mlx	Mlx	Mlx	Mlx
59	Mlx	Mlx	Mlx	Mlx	Mlx
60	Mlx	Mlx	Mlx	Mlx	Mlx
61	Mlx	Mlx	Mlx	Mlx	Mlx
62	Mlx	Mlx	Mlx	Mlx	Mlx
63	Mlx	Mlx	Mlx	Mlx	Mlx

*Table 6 EEPROM contents of Customer and Melexis general purpose data*

## 13. Standard information regarding manufacturability of Melexis products with different soldering processes

Our products are classified and qualified regarding soldering technology, solderability and moisture sensitivity level according to following test methods:

### Reflow Soldering SMD's (Surface Mount Devices)

- IPC/JEDEC J-STD-020  
Moisture/Reflow Sensitivity Classification for Nonhermetic Solid State Surface Mount Devices (classification reflow profiles according to table 5-2)
- EIA/JEDEC JESD22-A113  
Preconditioning of Nonhermetic Surface Mount Devices Prior to Reliability Testing (reflow profiles according to table 2)

### Wave Soldering SMD's (Surface Mount Devices) and THD's (Through Hole Devices)

- EN60749-20  
Resistance of plastic- encapsulated SMD's to combined effect of moisture and soldering heat
- EIA/JEDEC JESD22-B106 and EN60749-15  
Resistance to soldering temperature for through-hole mounted devices

### Iron Soldering THD's (Through Hole Devices)

- EN60749-15  
Resistance to soldering temperature for through-hole mounted devices

### Solderability SMD's (Surface Mount Devices) and THD's (Through Hole Devices)

- EIA/JEDEC JESD22-B102 and EN60749-21  
Solderability

For all soldering technologies deviating from above mentioned standard conditions (regarding peak temperature, temperature gradient, temperature profile etc) additional classification and qualification tests have to be agreed upon with Melexis.

The application of Wave Soldering for SMD's is allowed only after consulting Melexis regarding assurance of adhesive strength between device and board.

Melexis is contributing to global environmental conservation by promoting **lead free** solutions. For more information on qualifications of **RoHS** compliant products (RoHS = European directive on the Restriction Of the use of certain Hazardous Substances) please visit the quality page on our website: <http://www.melexis.com/quality.aspx>

## 14. Package Information

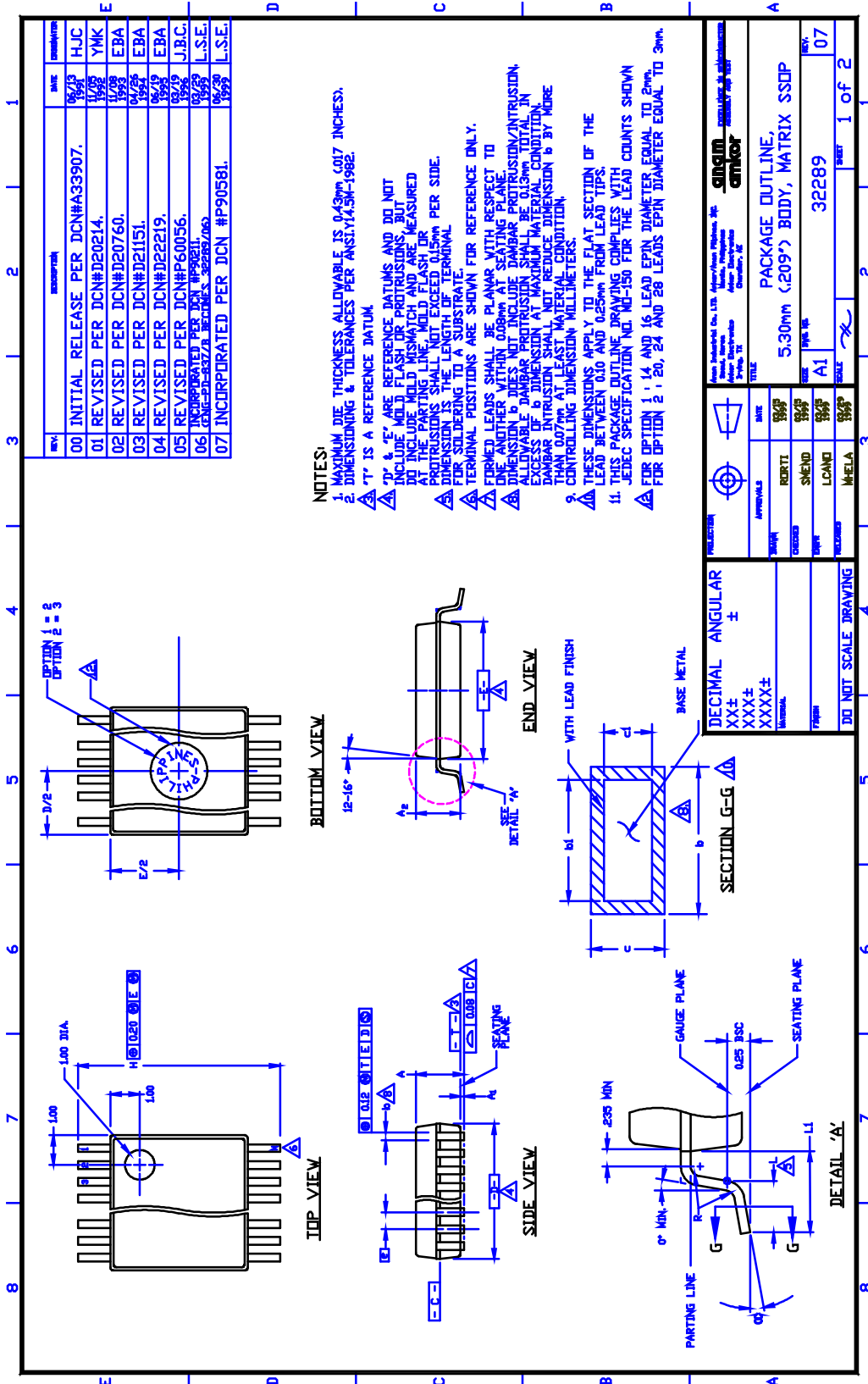



# MLX90320

Automotive Sensor Interface

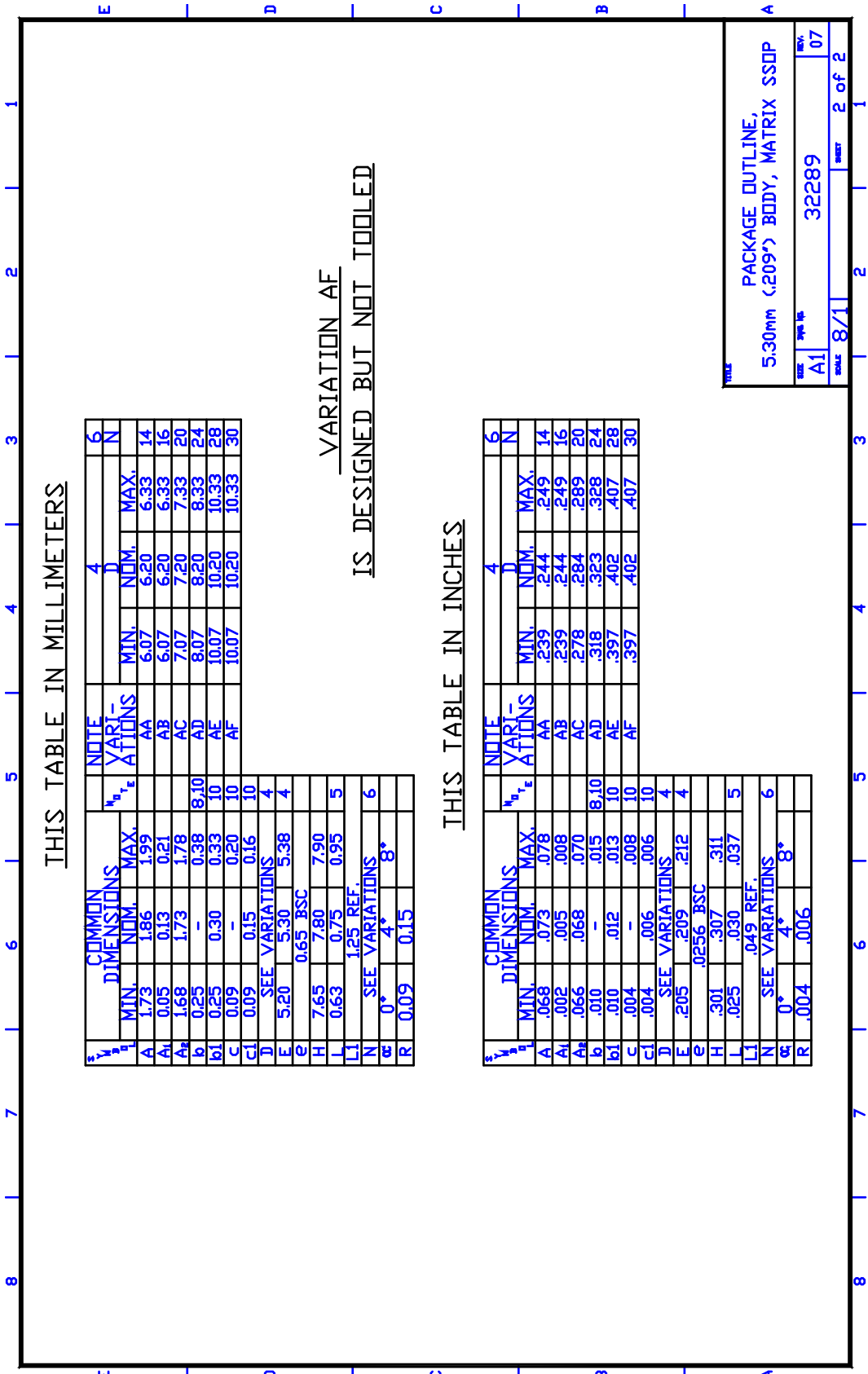

THIS TABLE IN MILLIMETERS

DIM.	COMMON DIMENSIONS		NOTE VARIATIONS	4		6	N
	MIN.	MAX.		MIN.	MAX.		
A	1.73	1.86	AA	6.07	6.20	6.33	14
A1	0.05	0.13	AB	6.07	6.20	6.33	16
A2	1.68	1.73	AC	7.07	7.20	7.33	20
b	0.25	-	AD	8.07	8.20	8.33	24
b1	0.25	0.30	AE	10.07	10.20	10.33	28
C	0.09	-	AF	10.07	10.20	10.33	30
Cl	0.09	0.15					
D	SEE VARIATIONS 4						
E	5.20	5.30					
e	0.65 BSC						
H	7.65	7.80					
L	0.63	0.75					
L1	1.25 REF.						
N	SEE VARIATIONS 6						
Ø	0°	4°					
R	0.09	0.15					

VARIATION AF IS DESIGNED BUT NOT TOOLED

THIS TABLE IN INCHES

DIM.	COMMON DIMENSIONS		NOTE VARIATIONS	4		6	N
	MIN.	MAX.		MIN.	MAX.		
A	.068	.073	AA	.239	.244	.249	14
A1	.002	.005	AB	.239	.244	.249	16
A2	.066	.068	AC	.278	.284	.289	20
b	.010	-	AD	.318	.323	.328	24
b1	.010	.012	AE	.397	.402	.407	28
C	.004	-	AF	.397	.402	.407	30
Cl	.004	.006					
D	SEE VARIATIONS 4						
E	.205	.209					
e	.0256 BSC						
H	.301	.307					
L	.025	.030					
L1	.049 REF.						
N	SEE VARIATIONS 6						
Ø	0°	4°					
R	.004	.006					

PACKAGE OUTLINE, 5.30mm (.209") BODY, MATRIX SSOP			
SIZE	PKG. NO.	REV.	
A1	32289	07	
SCALE	8/1	SHEET	2 of 2

## 15. Contact

For the latest version of this document, go to our website at [www.melexis.com](http://www.melexis.com).

For additional information, please contact our Direct Sales team and get help for your specific needs:

Europe, Africa	Telephone: +32 13 67 04 95
	Email : sales_europe@melexis.com
Americas	Telephone: +1 603 223 2362
	Email : sales_usa@melexis.com
Asia	Email : sales_asia@melexis.com

## 16. Disclaimer

*The information furnished by Melexis herein ("Information") is believed to be correct and accurate. Melexis disclaims (i) any and all liability in connection with or arising out of the furnishing, performance or use of the technical data or use of the product(s) as described herein ("Product") (ii) any and all liability, including without limitation, special, consequential or incidental damages, and (iii) any and all warranties, express, statutory, implied, or by description, including warranties of fitness for particular purpose, non-infringement and merchantability. No obligation or liability shall arise or flow out of Melexis' rendering of technical or other services.*

*The Information is provided "as is" and Melexis reserves the right to change the Information at any time and without notice. Therefore, before placing orders and/or prior to designing the Product into a system, users or any third party should obtain the latest version of the relevant information to verify that the information being relied upon is current.*

*Users or any third party must further determine the suitability of the Product for its application, including the level of reliability required and determine whether it is fit for a particular purpose.*

*The Information is proprietary and/or confidential information of Melexis and the use thereof or anything described by the Information does not grant, explicitly or implicitly, to any party any patent rights, licenses, or any other intellectual property rights.*

*This document as well as the Product(s) may be subject to export control regulations. Please be aware that export might require a prior authorization from competent authorities.*

*The Product(s) are intended for use in normal commercial applications. Unless otherwise agreed upon in writing, the Product(s) are not designed, authorized or warranted to be suitable in applications requiring extended temperature range and/or unusual environmental requirements. High reliability applications, such as medical life-support or life-sustaining equipment are specifically not recommended by Melexis.*

*The Product(s) may not be used for the following applications subject to export control regulations: the development, production, processing, operation, maintenance, storage, recognition or proliferation of 1) chemical, biological or nuclear weapons, or for the development, production, maintenance or storage of missiles for such weapons; 2) civil firearms, including spare parts or ammunition for such arms; 3) defense related products, or other material for military use or for law enforcement; 4) any applications that, alone or in combination with other goods, substances or organisms could cause serious harm to persons or goods and that can be used as a means of violence in an armed conflict or any similar violent situation.*

*The Products sold by Melexis are subject to the terms and conditions as specified in the Terms of Sale, which can be found at <https://www.melexis.com/en/legal/terms-and-conditions>.*

*This document supersedes and replaces all prior information regarding the Product(s) and/or previous versions of this document.*

*Melexis NV © - No part of this document may be reproduced without the prior written consent of Melexis. (2016)*

*ISO/TS 16949 and ISO14001 Certified*

## X-ON Electronics

Largest Supplier of Electrical and Electronic Components

*Click to view similar products for [Sensor Interface](#) category:*

*Click to view products by [Melexis](#) manufacturer:*

Other Similar products are found below :

[ZSC31150GEG1-T](#) [ZSSC4161BE2W](#) [MCZ33784EF](#) [FM-254-8-P](#) [LM1815MX/NOPB](#) [FM-213-4-P](#) [FM-215-8](#) [FM-253-4-P](#) [AS8510-ASSM](#)  
[AD598AD](#) [AD598JRZ](#) [AD598SD/883B](#) [743478D](#) [AD698APZ](#) [AD698SQ](#) [ADA4558WHCPZ-R7](#) [ADPD4000BCBZR7](#) [ADPD4001BCBZR7](#)  
[DRV401AIDWPR](#) [MAX9921AUB/V+T](#) [MAX1358BETL+](#) [MAX14827ATG+](#) [MAX14832ETB+](#) [MAX14829ATG+](#) [MAX14838GTC+T](#)  
[MAX22520GWP+](#) [MAX31911AUI+](#) [RE46C803SS20](#) [MAX14826GTG+](#) [MAX1452AAE+](#) [MAX31855SASA+T](#) [MAX31855EASA+](#)  
[MAX31855SASA+](#) [MAX31855TASA+](#) [MAX31855KASA+](#) [MAX31855KASA+T](#) [MAX31855NASA+](#) [MAX35102ETJ+](#) [MAX35103EHJ+](#)  
[MAX6682MUA+](#) [MAX86171ENI+](#) [MAX9921AUB+](#) [MAX9924UAUB+T](#) [MAX9925AUB+](#) [MAX9927AEE+](#) [MAX1454AUE/V+](#)  
[MAX1454AUE+](#) [RE46C800SS20](#) [SSC7102-GQ-AB2](#) [MAX6675ISA+](#)