

## 1. Features and Benefits

- Sensor interface IC for use in harsh automotive environments
- Possibilities to achieve outstanding overall sensor performances
- Ratiometric Analog Output

## 2. Application Examples

- Piezoresistive automotive pressure sensors interface
- Sensors based on Wheatstone bridge resistors

## 3. Ordering information

Product Code	Temperature Code	Package Code	Option Code	Packing form Code
MLX90328	L	DC	DBA-000	RE

Legend:

Temperature Code: L (-40°C to 150°C)

Package Code: DC = SOIC-8 Plastic Small Outline, 150 mil

Option Code: DBA-000

Packing Form: RE = Reel

Ordering example: MLX90328LDC-DBA-000-RE

## 4. Functional Diagram

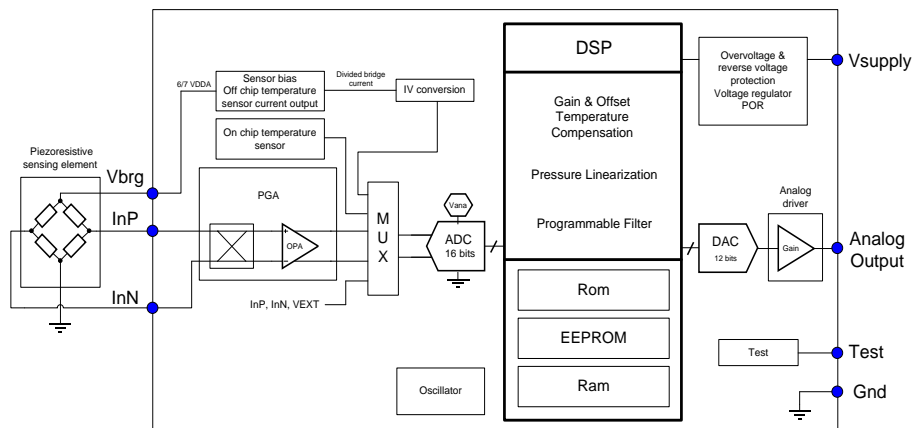

Figure 1: Functional block diagram

## 5. General Description

The MLX90328 covers the most typical resistive type of Wheatstone bridge applications for use in an automotive environment. It is a mixed signal sensor interface IC that converts small changes in resistors, configured in a full Wheatstone bridge on a sensing element, to large output voltage variations.

The signal conditioning includes gain adjustment, offset control as well as temperature compensation in order to accommodate variations of the different resistive sensing elements. Compensation values are stored in EEPROM and can be reprogrammed with a Melexis tool including the necessary software. The MLX90328 is programmed with a single wire serial interface through the output pin.

## Contents

1. Features and Benefits .....	1
2. Application Examples .....	1
3. Ordering information .....	1
4. Functional Diagram .....	1
5. General Description .....	1
6. Glossary of Terms.....	3
7. Absolute Maximum Ratings.....	3
8. Pin Definitions and Descriptions.....	3
9. General Electrical Specifications.....	4
10. Filters .....	6
10.1. PFLT.....	6
10.2. SSF.....	6
11. Analog Front End.....	7
12. ADC.....	9
13. Digital.....	9
14. Wrong Connections Overview.....	10
15. Diagnostics.....	11
15.1. Input Diagnostics.....	11
15.2. Diagnostic Sources .....	11
16. Unique Features.....	12
17. Application Information .....	13
18. Standard information regarding manufacturability of Melexis products with different soldering processes.....	14
19. ESD Precautions .....	14
20. Package Information .....	15
21. Contact .....	16
22. Disclaimer .....	16

## 6. Glossary of Terms

POR: Power-on Reset

ADC: Analog to Digital Converter

DSP: Digital Signal Processor

EMC: Electro Magnetic Compatibility

OV: Over Voltage

UV: Under Voltage

## 7. Absolute Maximum Ratings

Parameter	Symbol	Value	Units
Supply Voltage (overvoltage)	VDD	18	V
Reverse Voltage Protection		-14	V
Positive output voltage	Vout	18	V
Reverse output voltage		-0.5	V
Operating Temperature Range	T <sub>A</sub>	-40 to 150	°C
Storage Temperature Range	T <sub>S</sub>	-40 to 150	°C
Programming Temperature Range		-40 to 125	°C

*Table 1: Absolute maximum ratings*

Exceeding the absolute maximum ratings may cause permanent damage. Exposure to absolute-maximum-rated conditions for extended periods may affect device reliability.

## 8. Pin Definitions and Descriptions

Pin number SOIC8	Description
1	Vbrg: bridge supply voltage
2	InP: positive bridge output
3	Test: pin used for testing purposes only
4	InN: negative bridge output
5	Test: pin used for testing purposes only
6	Vsupply: IC supply
7	Out: Analog output
8	Gnd: Ground

*Table 2: Pin out definitions and descriptions*

Package side	Line number	Description
Top	1	Product number
Top	2	Lot number
Top	3	Sublot number (optional)
Bottom	1	Year and calendar week (yyww)

*Table 3: Package marking definition*

## 9. General Electrical Specifications

DC Operating Parameters  $T_A = -40^{\circ}\text{C}$  to  $150^{\circ}\text{C}$

Parameter	Symbol	Remarks	Min	Typ <sup>(1)</sup>	Max	Units
Nominal supply voltage	Vdd		4.5	5	5.5	V
Nominal supply current	Idd	Sensing element and output load current consumption excluded		8	10	mA
Decoupling capacitor on supply				100		nF
Capacitive load on output				100	470	nF
Resistive load on output		Pull-up or Pull-down	4.7			kOhm
Supply programming entry level	Vdd_com	Threshold to enter communication mode	6.2	7	7.8	V
Analog POR level (rising)			3.1	3.5	3.9	V
Analog POR hysteresis			100		500	mV
Digital POR level (rising)			2.05	2.3	2.7	V
Digital POR hysteresis			10		200	mV
Analog regulator	VDDA		-9%	3.5	+9%	V
Nominal bridge supply voltage	Vbrg		-9%	3	+9%	V
Power up time		Time from reaching minimum allowed supply voltage of 4.5V till having the output within specification			1.3	msec
Response time		Time needed for the output to change from an input pressure step to 90% of its final value. Using filter settings PFLT=0 and SSF=1. For response times using different filter settings see Table 5.			1	ms
Wheastone Bridge sensitivity range at 25degC <sup>(2)</sup>			2		55	mV/V
Wheastone Bridge resistance range			2			kOhm
Wheastone Bridge offset range			-20		20	mV/V
ADC resolution				16		Bits
InP InN digital diagnostic levels		Diagnostic thresholds of 25% of VDDA (low) and 75% of VDDA (high)	-16384		16384	lsb

<sup>1</sup> Typical values are defined at  $T_A = +25^{\circ}\text{C}$  and  $VDD = 5\text{V}$ .

<sup>2</sup> A maximum performance can be obtained with this sensor sensitivity range. A programmable gain with 5 bits from a gain of 9 to 237 is used in the analog front end circuitry to adapt the sensor range to the on chip ADC input range. Half of the ADC input range (= 1.75V) is foreseen to be used during the sensor calibration at the first temperature. The rest of the ADC input range is left for the compensation of the sensor temperature effects. A coarse offset compensation is available to calibrate large sensor offsets.

A more detailed overview of the gains in the analog frontend can be found in Table 6.

Parameter	Symbol	Remarks	Min	Typ <sup>(1)</sup>	Max	Units
Output noise using highest analog gain and lowest filter settings		Worst case noise configuration (PFLT=0, SSF=0, G0=30000d, CG=31)			1.4	mVrms
Overall accuracy		Taking into account the drifts over temperature and over life, worst case using typical and maximum gain settings		0.2	0.4	%FSO
Diagnostic limits	Diag low	Pull up $\geq 4.7k\Omega$ or Pull down $\geq 4.7k\Omega$			3	%VDD
	Diag high	Pull down $\geq 8k\Omega$ or Pull up $\geq 4.7k\Omega$	96			%VDD
Clamping levels	Clamp low	Programmable range with 7 bit resolution for the low clamping level, 9 bit for the high	0		12.5	%VDD
	Clamp high		50		100	%VDD
Analog saturation output level	Vsat high	PD $\geq 4.7k\Omega$ PD $\geq 10k$ or PU $\geq 4.7k$	96		100	%VDD
			97		100	%VDD
	Vsat low		0		3	%VDD

Table 4: General electrical parameters

## 10. Filters

There are two filters available to filter the pressure signal. The first filter is a Small Signal Filter which can be disabled or enabled. The second filter is a first order low pass filter for the pressure signal which has a programmable depth.

### 10.1. PFLT

PFLT is a programmable first order low pass filter. The depth of this filter can be selected. This filter can be configured to select the optimal trade-off between response time and output noise.

The low pass filter is implemented according to the following formula:

$$Filter_{output}(k) = \frac{Filter_{input}(k) - Filter_{output}(k - 1)}{2^{PFLT}} + Filter_{output}(k - 1)$$

The PFLT parameter in the formula is set in EEPROM and can have a value between 0 and 9. An overview of typical response times when applying a step on the input using different PFLT filter settings can be found in Table 5. Filter setting 0 disables the PFLT.

PFLT setting	Response time in ms <sup>(3)</sup>
0	0.93
1	1.25
2	2
3	3.7
4	7.1
5	13.7
6	27.0
7	53.8
8	106.8
9	203.8

Table 5: Filter settings and typical response times

### 10.2. SSF

The SSF (Small Signal Filter) is a digital filter which is designed not to have an impact on the response time of a fast changing pressure signal like a pressure step. When a large signal change at the input is present, the filter is bypassed and not filtering the signal. For small signal changes, which are in most cases noise, the filter is used and filtering the pressure signal.

The Small Signal Filter can be enabled or disabled in EEPROM.

---

<sup>3</sup> Time needed for the output to change from an input pressure step to 90% of its final value.

## 11. Analog Front End

The analog front end of the MLX90328 consists of a chopping stage and 3 amplification stages as can be seen in Figure 2. There are also several input diagnostics integrated into this front end to be able to detect a broken InP or InN connection or an input which is out of range. This diagnostic information is transferred to the microcontroller to handle further action for example flagging a diagnostic message.

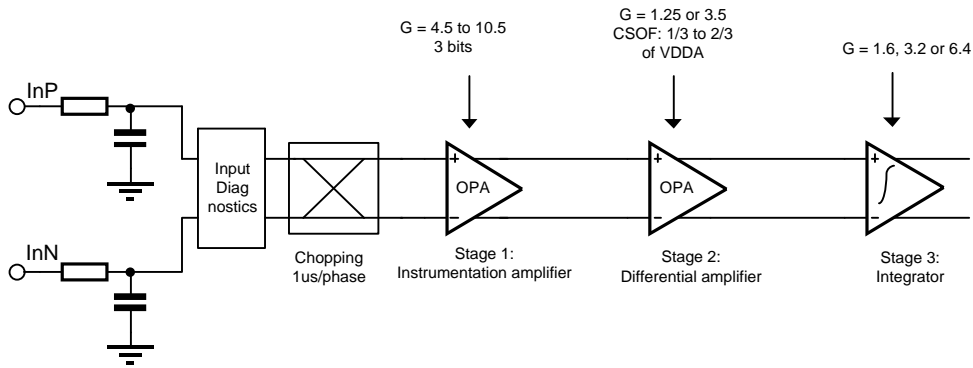

Figure 2: Analog front end block diagram

The first stage is an instrumentation amplifier of which the gain can be programmed using 3 bits to cover a gain range between 4.5 and 10.6.

Transfer equation:

$$\text{OUTP1} - \text{OUTN1} = \text{Gst1} * (\text{InP} - \text{InN}) \text{ in phase 1}$$

$$\text{OUTP1} - \text{OUTN1} = \text{Gst1} * (\text{InN} - \text{InP}) \text{ in phase 2}$$

The second stage is a fully differential amplifier. The gain of the amplifier can be calibrated using 1 bit.

Transfer equation:

$$\text{OUTP2} - \text{OUTN2} = -\text{Gst2} * (\text{OUTP1} - \text{OUTN1}) - \text{Gst2} * (\text{CSOF1} - \text{CSOF2}) \text{ in phase 1}$$

$$\text{OUTP2} - \text{OUTN2} = -\text{Gst2} * (\text{OUTN1} - \text{OUTP1}) - \text{Gst2} * (\text{CSOF2} - \text{CSOF1}) \text{ in phase 2}$$

The CSOF1 and CSOF2 signals are generated by the coarse offset DAC with the following transfer functions:

$$\text{CSOF1} = \frac{\text{VDDA}}{2} + (-1)^{\text{CO7}} * \left( \frac{2}{3} - \frac{1}{3} \right) * \frac{\text{VDDA}}{2} * \frac{\text{CO}[6:0]}{127}$$

$$\text{CSOF2} = \frac{\text{VDDA}}{2} - (-1)^{\text{CO7}} * \left( \frac{2}{3} - \frac{1}{3} \right) * \frac{\text{VDDA}}{2} * \frac{\text{CO}[6:0]}{127}$$

CO[6:0] fixes the DAC output. CO7 is used for the polarity.

The third stage is an integrator which is controlled using 2 bits to set a gain between 1.6 and 6.4

Transfer equation at the outputs of the amplifier:

$$\text{OUTP3} - \text{OUTN3} = -N * (\text{C1}/\text{C2}) * (\text{OUTP2} - \text{OUTN2})$$

$$\text{OUTP3\_common\_mode} \text{ and } \text{OUTN3\_common\_mode} = \text{VCM} = \text{VDDA}/2$$

In this equation N represents the number of integration cycles which is a fixed value of N = 40.

C2 is a fixed feedback capacitor of approximately 5pF. C1 can have 3 different values: 0.2pF, 0.4pF or 0.8pF.

Transfer equation after the ADC:

$$\text{Pressure\_ADC} = ((\text{OUTN3} - \text{OUTP3}) * 2^{16} / \text{VDDA}) + 32768$$

An overview of all possible values for Gst1, Gst2 and Gst3 can be found in Table 6 below.  
 The input stage is designed to work with an input common-mode voltage range between 42%Vbrg and 58%Vbrg.

Gain setting [-]	Gst1 [V/V]	Gst2 [V/V]	Gst3 [V/V]	Total gain [V/V]	FS Differential input signal [mV]
0	4.49	-1.25	1.6	-9.0	± 195
1	5.06	-1.25	1.6	-10.1	± 173
2	5.8	-1.25	1.6	-11.6	± 151
3	6.52	-1.25	1.6	-13.0	± 134
4	7.43	-1.25	1.6	-14.9	± 118
5	8.37	-1.25	1.6	-16.7	± 105
6	9.35	-1.25	1.6	-18.7	± 94
7	10.6	-1.25	1.6	-21.2	± 83
8	4.49	-3.5	1.6	-25.1	± 70
9	5.06	-3.5	1.6	-28.3	± 62
10	5.8	-3.5	1.6	-32.5	± 54
11	6.52	-3.5	1.6	-36.5	± 48
12	7.43	-3.5	1.6	-41.6	± 42
13	8.37	-3.5	1.6	-46.9	± 37
14	9.35	-3.5	1.6	-52.4	± 33
15	10.6	-3.5	1.6	-59.4	± 29
16	4.49	-3.5	3.2	-50.3	± 35
17	5.06	-3.5	3.2	-56.7	± 31
18	5.8	-3.5	3.2	-65.0	± 27
19	6.52	-3.5	3.2	-73.0	± 24
20	7.43	-3.5	3.2	-83.2	± 21
21	8.37	-3.5	3.2	-93.7	± 19
22	9.35	-3.5	3.2	-104.7	± 17
23	10.6	-3.5	3.2	-118.7	± 15
24	4.49	-3.5	6.4	-100.6	± 17
25	5.06	-3.5	6.4	-113.3	± 15
26	5.8	-3.5	6.4	-129.9	± 13
27	6.52	-3.5	6.4	-146.0	± 12
28	7.43	-3.5	6.4	-166.4	± 11
29	8.37	-3.5	6.4	-187.5	± 9
30	9.35	-3.5	6.4	-209.4	± 8
31	10.6	-3.5	6.4	-237.4	± 7

Table 6: Gain and input signal range of the analog front end



## 12. ADC

The 16 bit differential ADC has a range from  $-VDDA/2$  to  $+VDDA/2$ .

There are 7 different ADC channels. Channel 0 is not used. Table 7 below describes all the channels.

ADC	Signal	Remarks
SIN[2:0]		
0	-	Nothing connected
1	P	Pressure
2	Tint	Internal Temperature
3	Vsup	External Supply
4	InP/InN	Multiplexing between Positive/Negative Sensor Output
5	Vdig	Digital Regulator
6	Tntc	NTC Output
7	Text	External Temperature

Table 7: ADC channels

The different channels are converted in a constantly repeating sequence. A new ADC conversion is done every 50us following the sequence shown below in Figure 3. This is resulting in an updated pressure output value every 200us.

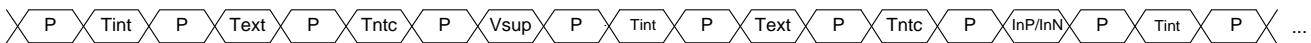

Figure 3: ADC sequence

## 13. Digital

The digital is built around a 16-bit microcontroller. It contains besides the processor also ROM, RAM and EEPROM and a set of user and system IO registers.

Temperature compensation of the pressure signal and pressure linearization is handled by the microcontroller. For the pressure compensation there are EEPROM parameters allocated to be able to cover a large variety of calibration approaches.

Both for gain and offset of the pressure signal, there is a separate temperature dependency programmable ranging from a temperature independence to a first order, second order and finally a third order compensation. This is reflected in EEPROM parameters for the offset (O0, O1, O2 and O3) and for the gain (G0, G1, G2 and G3). If required, the linearity of the pressure signal can also be compensated without a temperature dependency or with a first order temperature dependency through EEPROM parameters L0 and L1.

For the temperature compensation of the pressure signal both the internal on-chip temperature as the temperature measured using the sensor bridge resistance can be used. The selection between both can be set in EEPROM using the 'Tpress Select' parameter. When using the bridge resistance temperature measurement, a

selection of a 2K, 4K, 8K or a 32K bridge resistance can be done using EEPROM parameter 'BRIDGE\_SEL'<sup>(4)</sup>, see Table 8.

BRIDGE_SEL	Resistance selection
0	2K
1	4K
2	8K
3	32K

Table 8: Bridge resistance selection for temperature reference

## 14. Wrong Connections Overview

Table 9 provides an overview of the behavior of the MLX90328 when different combinations of connections to GND, VDD and OUT are made.

GND	VDD	Analog out	Effect on output	Action after wrong connection
0V	5V	Pull-down or Pull-up	Normal operation	Normal operation
Disconnected	5V	Pull-down or Pull-up	High Fault Band	Normal operation
0V	Disconnected	Pull-down or Pull-up	Low Fault Band	Normal operation
0V	5V	Disconnected	Low Fault Band for Pull-down High Fault Band for Pull-up	Normal operation
0V	5V	0V	Low Fault Band	Normal operation
0V	5V	5V	High Fault Band	Normal operation
0V	5V	18V	18V	Normal operation
0V	0V	Pull-down or Pull-up	Low Fault Band	Normal operation
0V	18V	Pull-down or Pull-up	Low Fault Band for Pull-down High Fault Band for Pull-up	Normal operation
5V	5V	Pull-down or Pull-up	High Fault Band	Normal operation
5V	0V	Pull-down or Pull-up		Normal operation

Table 9: Wrong connections overview

<sup>4</sup> It is not mandatory to have a bridge resistance identical to the resistance selection setting. In this case it is advised to select the setting closest to the actual value. In case support is needed please contact Melexis.

## 15. Diagnostics

### 15.1. Input Diagnostics

An overview of the different input diagnostics conditions and their corresponding fault band and diagnostic source can be found in Table 10.

Condition	Fault Band	Diagnostic Source
Vbrg disconnected	Low	ERR_EN_SPSN
GND (sensor) disconnected	Low	ERR_EN_SPSN
InP disconnected	Low	ERR_EN_BW
InN disconnected	Low	ERR_EN_BW
Vbrg shorted to GND	Low	ERR_EN_SPSN
InP shorted to GND	Low	ERR_EN_SPSN
InN shorted to GND	Low	ERR_EN_SPSN
InP shorted to Vbrg	Low	ERR_EN_SPSN
InN shorted to Vbrg	Low	ERR_EN_SPSN

*Table 10: Input diagnostics*

### 15.2. Diagnostic Sources

The MLX90328 product has several internal checks which monitor the status of device. These checks or diagnostic sources can be enabled or disabled based on the sensor module requirements. An overview of the different diagnostic sources, their enable/disable parameter and the explanation of their functionality can be found below in Table 11.

Parameter	Error condition
ERR_EN_TINT	The Internal temperature could not be measured/calculated
ERR_EN_IO	RAM configuration error
ERR_EN_SPSN	SP or SN pin voltage out of range
ERR_EN_PV	The pressure value could not be measured/calculated
ERR_EN_PP	Pressure parameter error
ERR_EN_BW	A broken wire is detected in the pressure sensor path
ERR_EN_VSUPH	The supply voltage is too high
ERR_EN_VSUPL	The supply voltage is too low
ERR_EN_TCHIP	The chip temperature out of range

*Table 11: Diagnostic sources*

The level of the over and under voltage diagnostics can be configured according to the ranges described in Table 12.

Parameter	Min	Max	Units	Comment
Under voltage detection threshold range	3.25	5.74	V	Optional and Programmable with 8 bits in parameter VSUP_LOW
Overvoltage detection threshold range	4.25	6.74	V	Optional and Programmable with 8 bits in parameter VSUP_HIGH
Over-/Under-voltage detection accuracy		200	mV	

Table 12: MLX90818 under and overvoltage detection

## 16. Unique Features

Thanks to its state of the art mixed signal chain, the MLX90328 offers the possibility to calibrate several types of resistive Wheatstone bridge technologies allowing the MLX90328 users to reach an outstanding overall sensor accuracy. The MLX90328 is robust for harsh automotive environments like large temperature range, overvoltage conditions and external EMC disturbances.

The MLX90328 allows the compensation of sensor nonlinear variations over temperature as well as compensates for the sensor pressure signal non linearity. Several parameters can be programmed through the application pins in the MLX90328 to set clamping levels or filter settings to choose for the best trade-off between signal chain noise and speed. The MLX90328 can also diagnose several error conditions like sensor connections errors.

The sensor bias Vbrg which is supplying the external pressure sensor is generated using a regulator. The target sensor supply is  $6/7V_{DDA}$  or typically 3V. The current through the bridge resistance is mirrored and divided so that it can be fed to an IV convertor. The division ratio is depending on the EEPROM selection bit IVSEL which chooses a different ratio for a 2K, 4K, 8K or a 32K sensor bridge. This IV converted signal is a measure for the external temperature so that it can be used for the calibration of the pressure sensor. A short circuit protection is foreseen on the pin Vbrg.

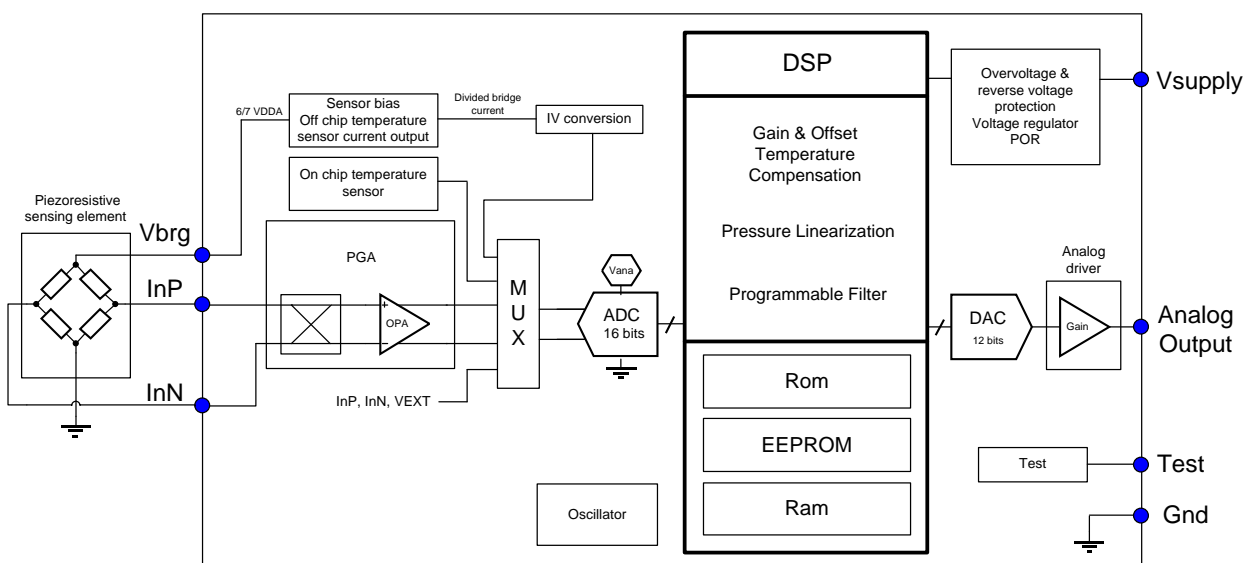

Figure 4: MLX90328 block diagram

## 17. Application Information

The MLX90328 only needs 2 capacitors in the application. A 100nF decoupling capacitor connected between the supply line and the ground a 100nF load between the analog output pin and the ground.

MLX90328 has built in EMC protection for the sensor supply and sensing element input pins. Therefore it is advised not to place any external capacitors between the sensing element and the interface. Capacitors on the sensor supply or the inputs can even disturb the normal operation of the interface.

These recommendations for external components are however only providing a basic protection. Depending on the module design and the EMC requirements different configurations can be needed.

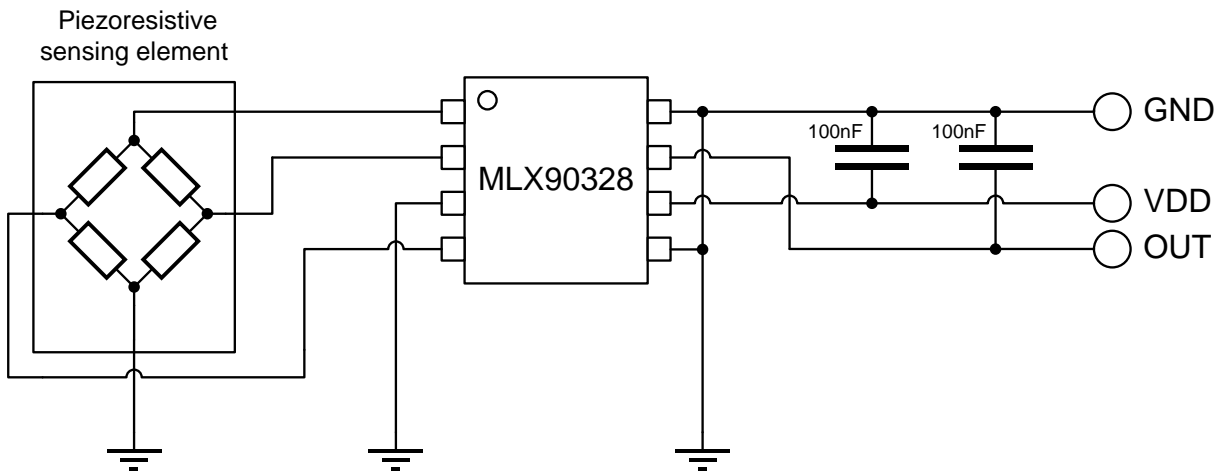

*Figure 5: MLX90328 basic application schematic*

## 18. Standard information regarding manufacturability of Melexis products with different soldering processes

Our products are classified and qualified regarding soldering technology, solderability and moisture sensitivity level according to following test methods:

### Reflow Soldering SMD's (Surface Mount Devices)

- IPC/JEDEC J-STD-020  
Moisture/Reflow Sensitivity Classification for Nonhermetic Solid State Surface Mount Devices (classification reflow profiles according to table 5-2)
- EIA/JEDEC JESD22-A113  
Preconditioning of Nonhermetic Surface Mount Devices Prior to Reliability Testing (reflow profiles according to table 2)

### Wave Soldering SMD's (Surface Mount Devices) and THD's (Through Hole Devices)

- EN60749-20  
Resistance of plastic- encapsulated SMD's to combined effect of moisture and soldering heat
- EIA/JEDEC JESD22-B106 and EN60749-15  
Resistance to soldering temperature for through-hole mounted devices

### Iron Soldering THD's (Through Hole Devices)

- EN60749-15  
Resistance to soldering temperature for through-hole mounted devices

### Solderability SMD's (Surface Mount Devices) and THD's (Through Hole Devices)

- EIA/JEDEC JESD22-B102 and EN60749-21  
Solderability

For all soldering technologies deviating from above mentioned standard conditions (regarding peak temperature, temperature gradient, temperature profile etc) additional classification and qualification tests have to be agreed upon with Melexis.

The application of Wave Soldering for SMD's is allowed only after consulting Melexis regarding assurance of adhesive strength between device and board.

Melexis is contributing to global environmental conservation by promoting **lead free** solutions. For more information on qualifications of **RoHS** compliant products (RoHS = European directive on the Restriction Of the use of certain Hazardous Substances) please visit the quality page on our website: <http://www.melexis.com/quality.aspx>

## 19. ESD Precautions

Electronic semiconductor products are sensitive to Electro Static Discharge (ESD). Always observe Electro Static Discharge control procedures whenever handling semiconductor products.

## 20. Package Information

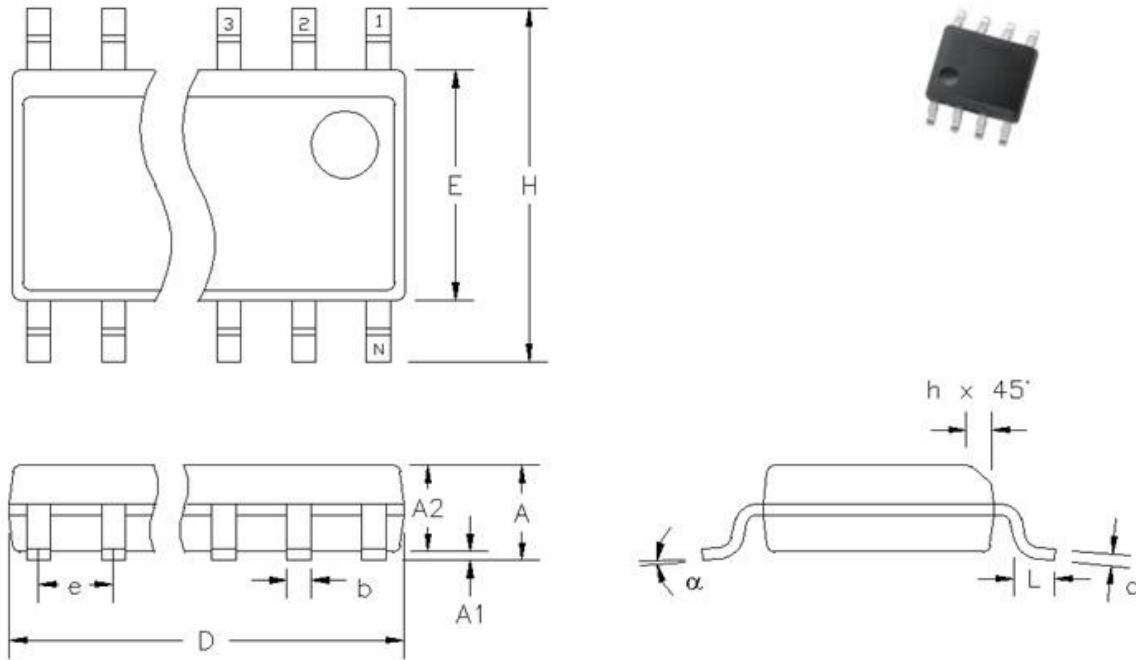

Figure 6: Package drawing

Package dimensions in mm

N		A	A1	A2	D	E	H	L	b	c	e	h	$\alpha$
8	min	1.52	0.10	1.37	4.80	3.91	5.80	0.41	0.35	0.19	1.27	0.25	0°
	max	1.73	0.25	1.57	4.98	3.99	6.20	1.27	0.49	0.25	BSC	0.50	8°

Package dimensions in inch

N		A	A1	A2	D	E	H	L	b	c	e	h	$\alpha$
8	min	.060	.004	.054	.189	.150	.228	.016	.014	.008	.050	.010	0°
	max	.068	.010	.062	.196	.157	.244	.050	.019	.010	BSC	.020	8°

Table 13: Package dimensions in mm and inch

## 21. Contact

For the latest version of this document, go to our website at [www.melexis.com](http://www.melexis.com).

For additional information, please contact our Direct Sales team and get help for your specific needs:

Europe, Africa	Telephone: +32 13 67 04 95
	Email : sales_europe@melexis.com
Americas	Telephone: +1 603 223 2362
	Email : sales_usa@melexis.com
Asia	Email : sales_asia@melexis.com

## 22. Disclaimer

*The information furnished by Melexis herein ("Information") is believed to be correct and accurate. Melexis disclaims (i) any and all liability in connection with or arising out of the furnishing, performance or use of the technical data or use of the product(s) as described herein ("Product") (ii) any and all liability, including without limitation, special, consequential or incidental damages, and (iii) any and all warranties, express, statutory, implied, or by description, including warranties of fitness for particular purpose, non-infringement and merchantability. No obligation or liability shall arise or flow out of Melexis' rendering of technical or other services.*

*The Information is provided "as is" and Melexis reserves the right to change the Information at any time and without notice. Therefore, before placing orders and/or prior to designing the Product into a system, users or any third party should obtain the latest version of the relevant information to verify that the information being relied upon is current. Users or any third party must further determine the suitability of the Product for its application, including the level of reliability required and determine whether it is fit for a particular purpose.*

*The Information is proprietary and/or confidential information of Melexis and the use thereof or anything described by the Information does not grant, explicitly or implicitly, to any party any patent rights, licenses, or any other intellectual property rights.*

*This document as well as the Product(s) may be subject to export control regulations. Please be aware that export might require a prior authorization from competent authorities.*

*The Product(s) are intended for use in normal commercial applications. Unless otherwise agreed upon in writing, the Product(s) are not designed, authorized or warranted to be suitable in applications requiring extended temperature range and/or unusual environmental requirements. High reliability applications, such as medical life-support or life-sustaining equipment are specifically not recommended by Melexis.*

*The Product(s) may not be used for the following applications subject to export control regulations: the development, production, processing, operation, maintenance, storage, recognition or proliferation of 1) chemical, biological or nuclear weapons, or for the development, production, maintenance or storage of missiles for such weapons; 2) civil firearms, including spare parts or ammunition for such arms; 3) defense related products, or other material for military use or for law enforcement; 4) any applications that, alone or in combination with other goods, substances or organisms could cause serious harm to persons or goods and that can be used as a means of violence in an armed conflict or any similar violent situation.*

*The Products sold by Melexis are subject to the terms and conditions as specified in the Terms of Sale, which can be found at <https://www.melexis.com/en/legal/terms-and-conditions>.*

*This document supersedes and replaces all prior information regarding the Product(s) and/or previous versions of this document.*

*Melexis NV © - No part of this document may be reproduced without the prior written consent of Melexis. (2016)*

*ISO/TS 16949 and ISO14001 Certified*



## X-ON Electronics

Largest Supplier of Electrical and Electronic Components

*Click to view similar products for [Sensor Interface](#) category:*

*Click to view products by [Melexis](#) manufacturer:*

Other Similar products are found below :

[ZSC31150GEG1-T](#) [ZSSC4161BE2W](#) [MCZ33784EF](#) [LM1815MX/NOPB](#) [FM-213-4-P](#) [MAX31850KATB+](#) [FM-252-4](#) [FM-215-8](#) [FM-216-AR2](#) [FM-253-4-P](#) [AS8510-ASSM](#) [AD598AD](#) [AD598JRZ](#) [AD598SD/883B](#) [743478D](#) [AD698APZ](#) [AD698SQ](#) [ADA4558WHCPZ-R7](#) [ADPD4000BCBZR7](#) [ADPD4001BCBZR7](#) [DRV401AIDWPR](#) [MAX1358BETL+](#) [MAX14827ATG+](#) [MAX14832ETB+](#) [MAX14838GTC+T](#) [MAX22520GWP+](#) [MAX31911AUI+](#) [RE46C803SS20](#) [MAX14826GTG+](#) [MAX1452AAE+](#) [MAX31855SASA+T](#) [MAX31855EASA+](#) [MAX31855SASA+](#) [MAX31855TASA+](#) [MAX31855KASA+T](#) [MAX31855NASA+](#) [MAX35102ETJ+](#) [MAX35103EHJ+](#) [MAX6682MUA+](#) [MAX86171ENI+](#) [MAX9921AUB+](#) [MAX9924UAUB+T](#) [MAX9925AUB+](#) [MAX9927AEE+](#) [MAX1454AUE/V+](#) [MAX1454AUE+](#) [RE46C800SS20](#) [SSC7102-GQ-AB2](#) [MAX6675ISA+](#) [MAX6674ISA+](#)