

# PTC04-DB-HALL06

Daughter Board for Melexis PTC devices



Figure 1: PTC04-DB-HALL06

## Features and Benefits

PTC04 interface board for testing devices:

- MLX90371
- MLX90372
- MLX90373
- MLX90374
- MLX90378
- MLX90380
- MLX91372

## Ordering Information

### Part No.

PTC04-DB-Hall-06 V4.0

### Description

Daughter Board (PCB + rear panel PTC04)

## Accessories

### Part No.

DLL's for all supported products  
User Interfaces for supported products

## Applications

Experimental tool for Lab and Prototyping  
Production Equipment for Serial Programming

## Functional Diagram

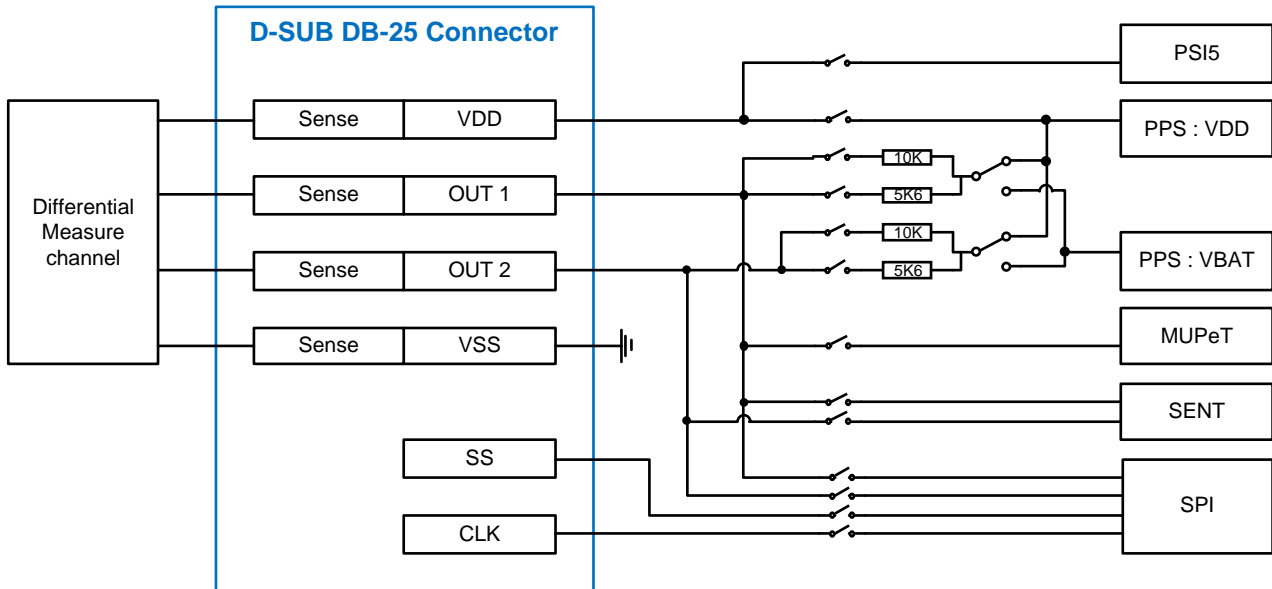

Figure 2: Functional diagram

## Contents

Features and Benefits.....	1
Applications .....	1
Ordering Information .....	1
Accessories.....	1
Functional Diagram .....	2
Contents .....	2
<b>1. Board description .....</b>	<b>3</b>
1.1. Board Layout .....	3
1.2. Board Schematic.....	4
1.3. Daughter board Connectors .....	9
1.3.1. Digital DB Connector (40 Pins).....	10
1.3.2. Analog DB Connector (48 Pins).....	10
1.4. Application Connector .....	11
1.5. Jumper Selection .....	16
1.5.1. CON18 and CON19 – short measuring lines .....	16
1.5.2. J2, J3, J4 and J5 – select pull-up.....	17
1.5.3. CON3 and CON21 – configure MUPeT circuit.....	17
<b>2. Contact.....</b>	<b>18</b>
<b>3. Disclaimer.....</b>	<b>18</b>

# 1. Board description

## 1.1. Board Layout

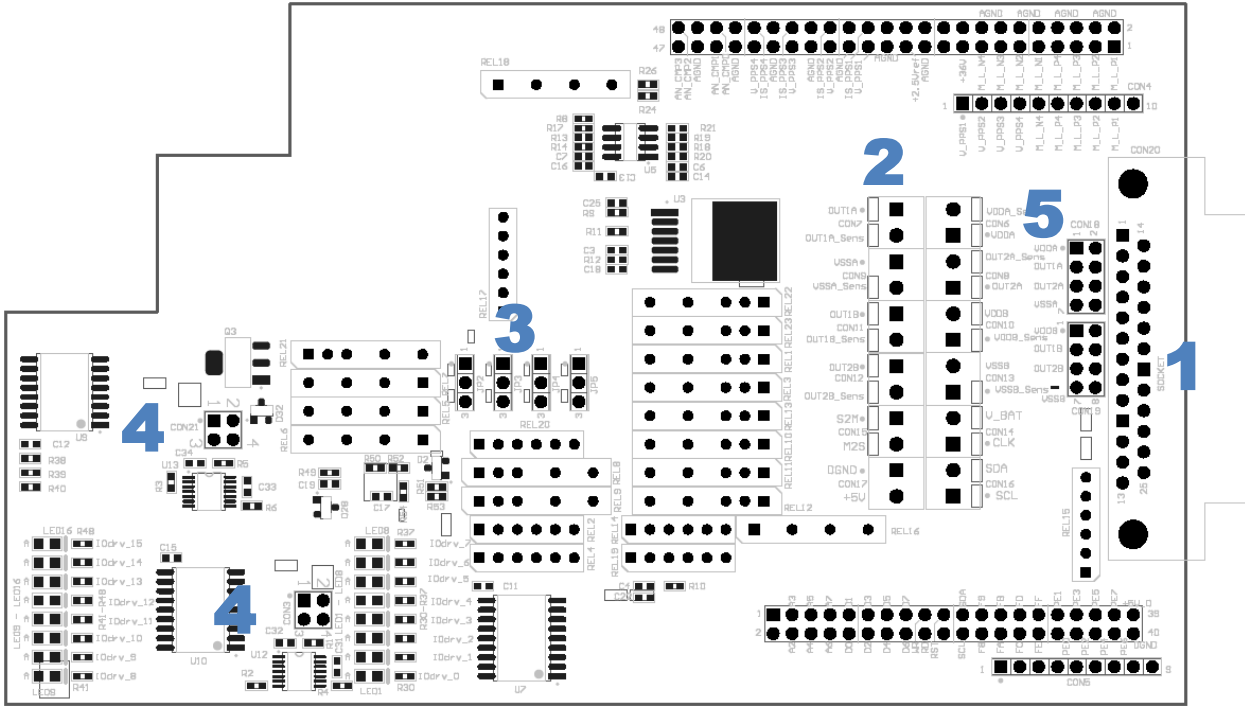

Figure 3: Top layer

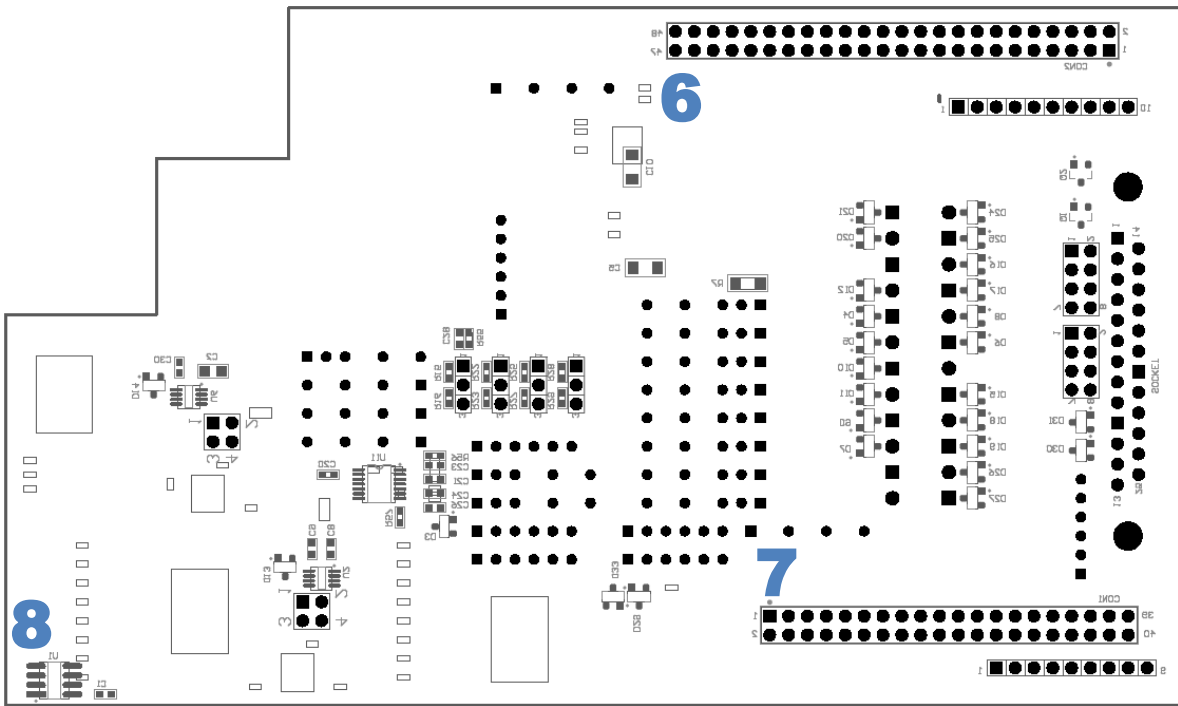

Figure 4: Bottom layer

1. DB-25 Connector (CON20): Connector to the application.
2. Screw terminal (CON7-16): Alternative connection to the application.
3. JP2, JP3, JP4, and JP5: Select 5K6 or 10 K for pull-up load to VDD or Vbat, resp. for OUT1A, OUT2A, OUT1B and OUT2B.
4. CON3 and CON21 Jumpers to select a 100 Ohm resistor or the digital potentiometer for MUPeT protocol.
5. CON18 and CON19 Jumpers to short the sensing lines at the device connector.
6. Analog (CON2) connector.
7. Digital (CON1) connector.
8. U1 This EEPROM memory keeps a few initial variables in mind. It allows for example to detect what DB is connected to the programmer and if the DB is not expired.

See below for a detailed description on the connectors and the jumper configurations.

## 1.2. Board Schematic

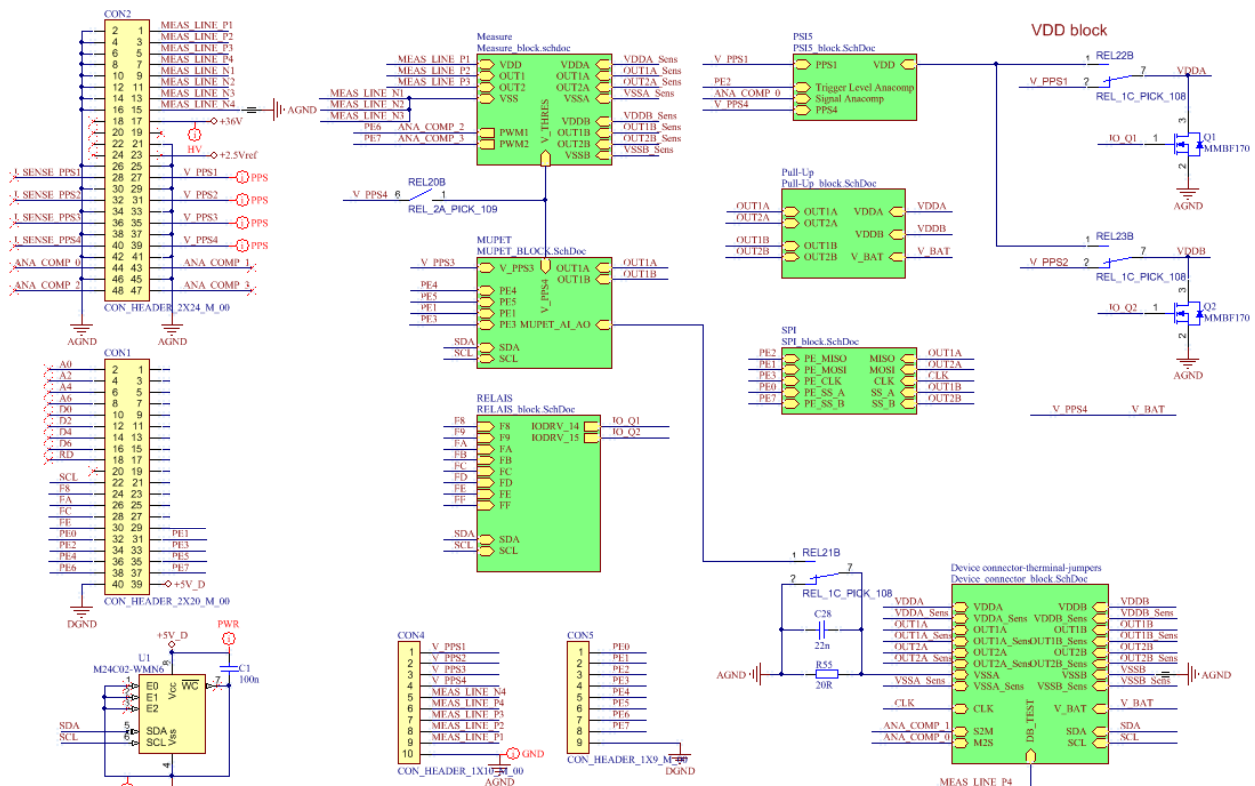

Figure 5: Main schematic



Figure 6: Pull-Up Block

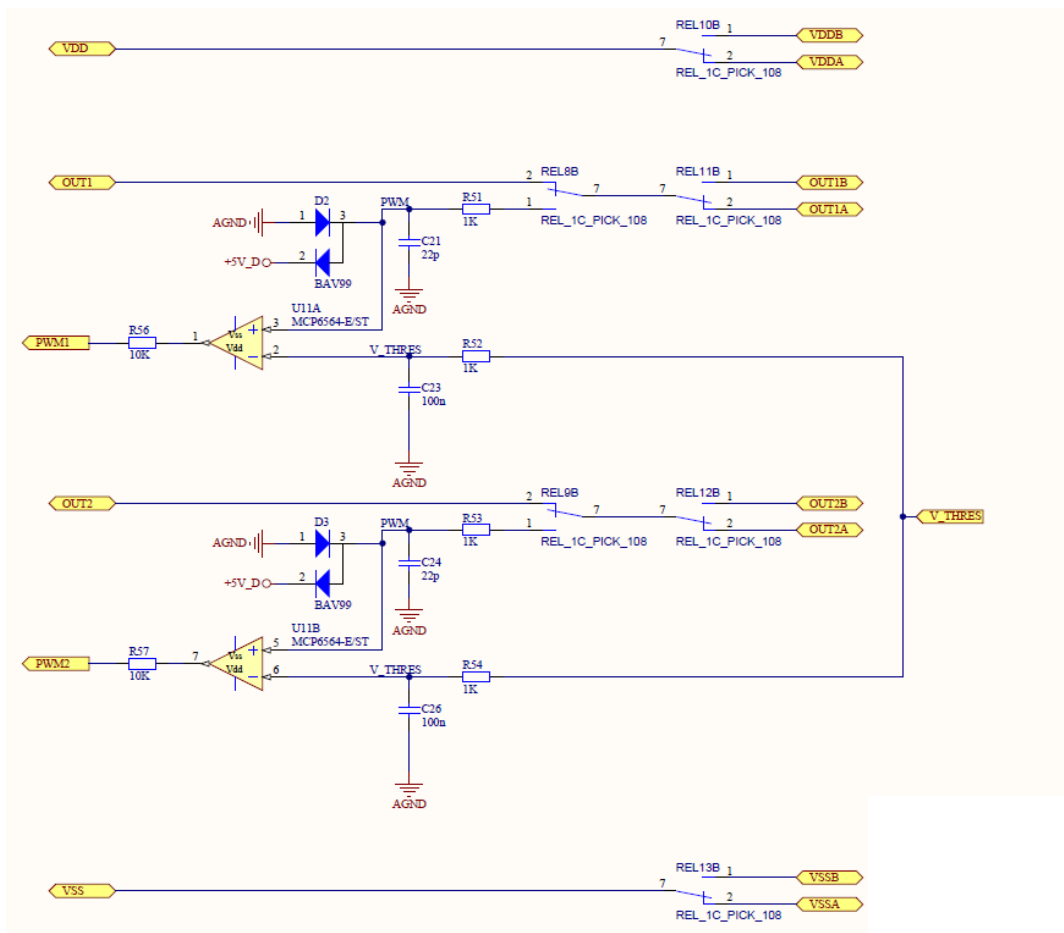

Figure 7: Measure Block

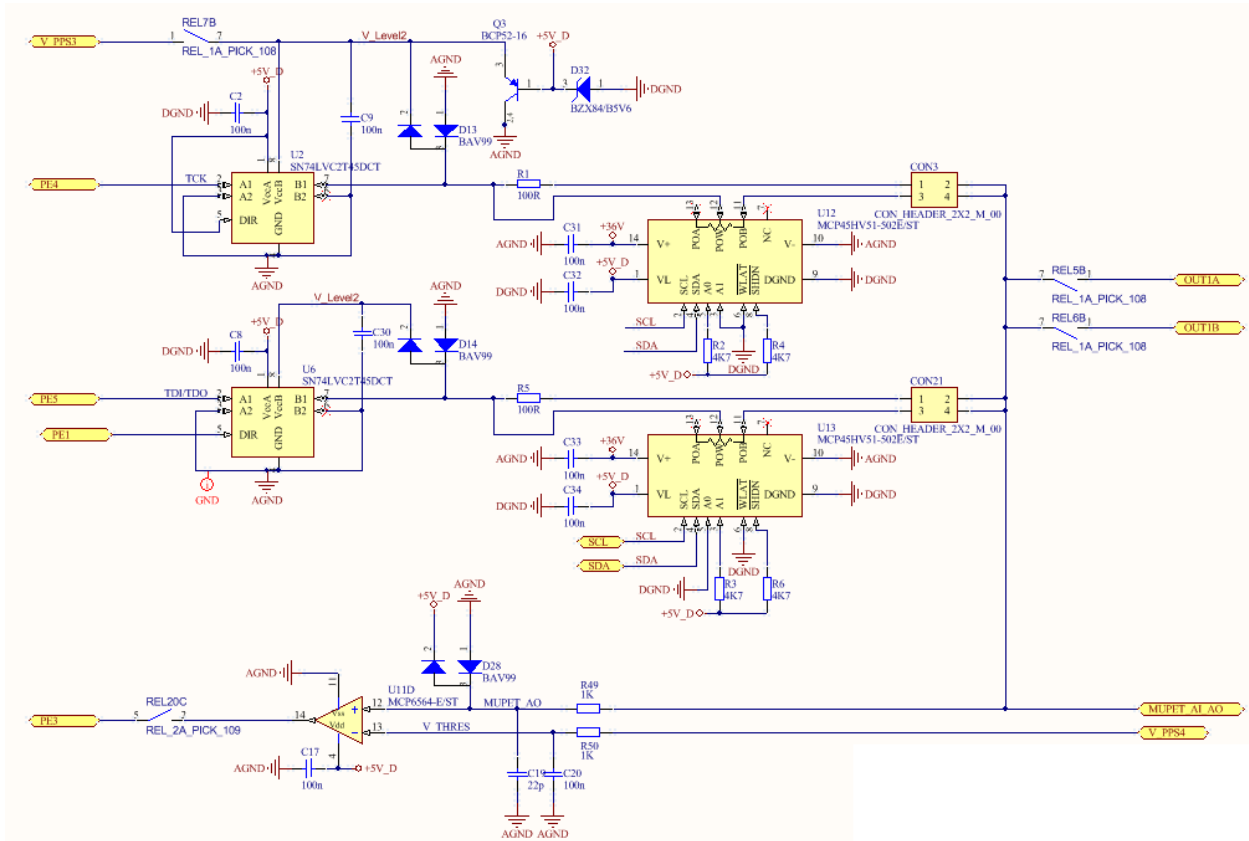

Figure 8: MUPET Block

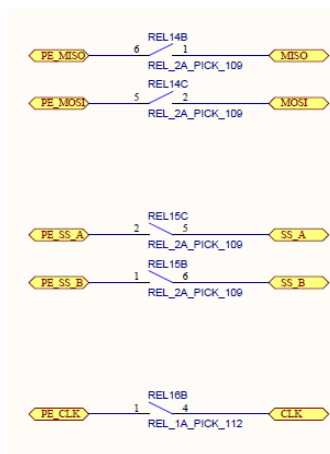

Figure 9: SPI Block



Figure 10: Device Connector Block

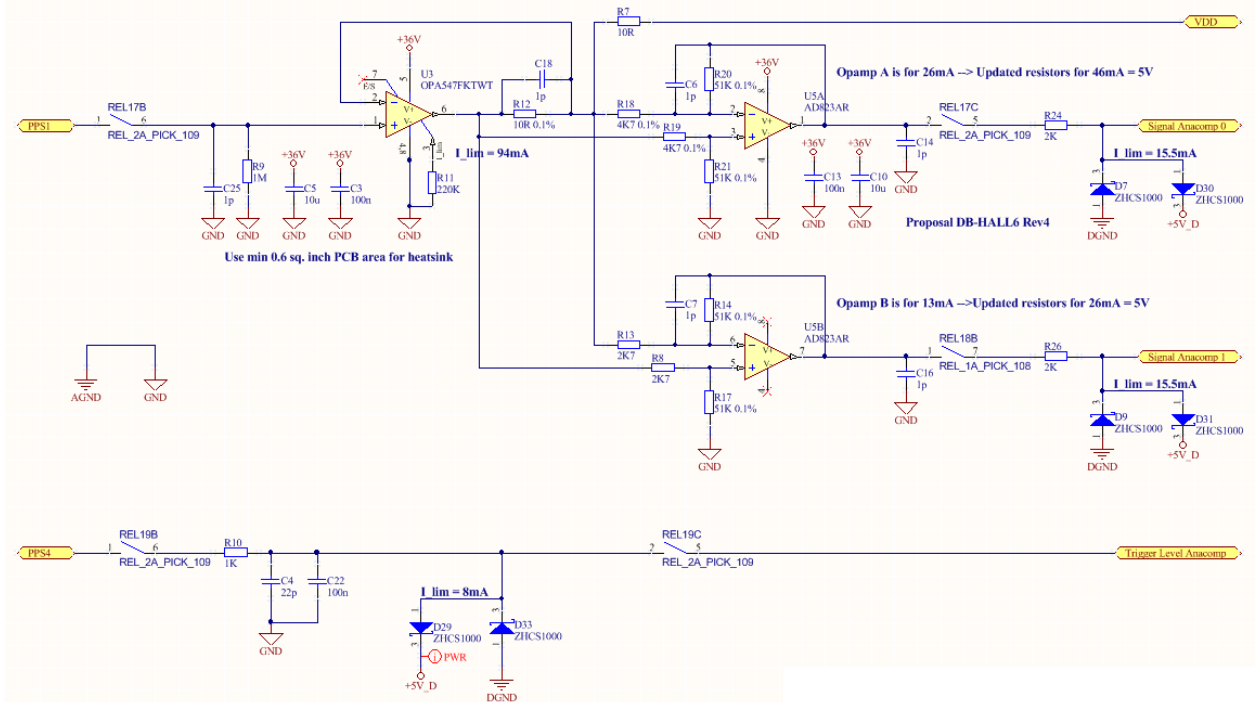

Figure 11: PS15 Block

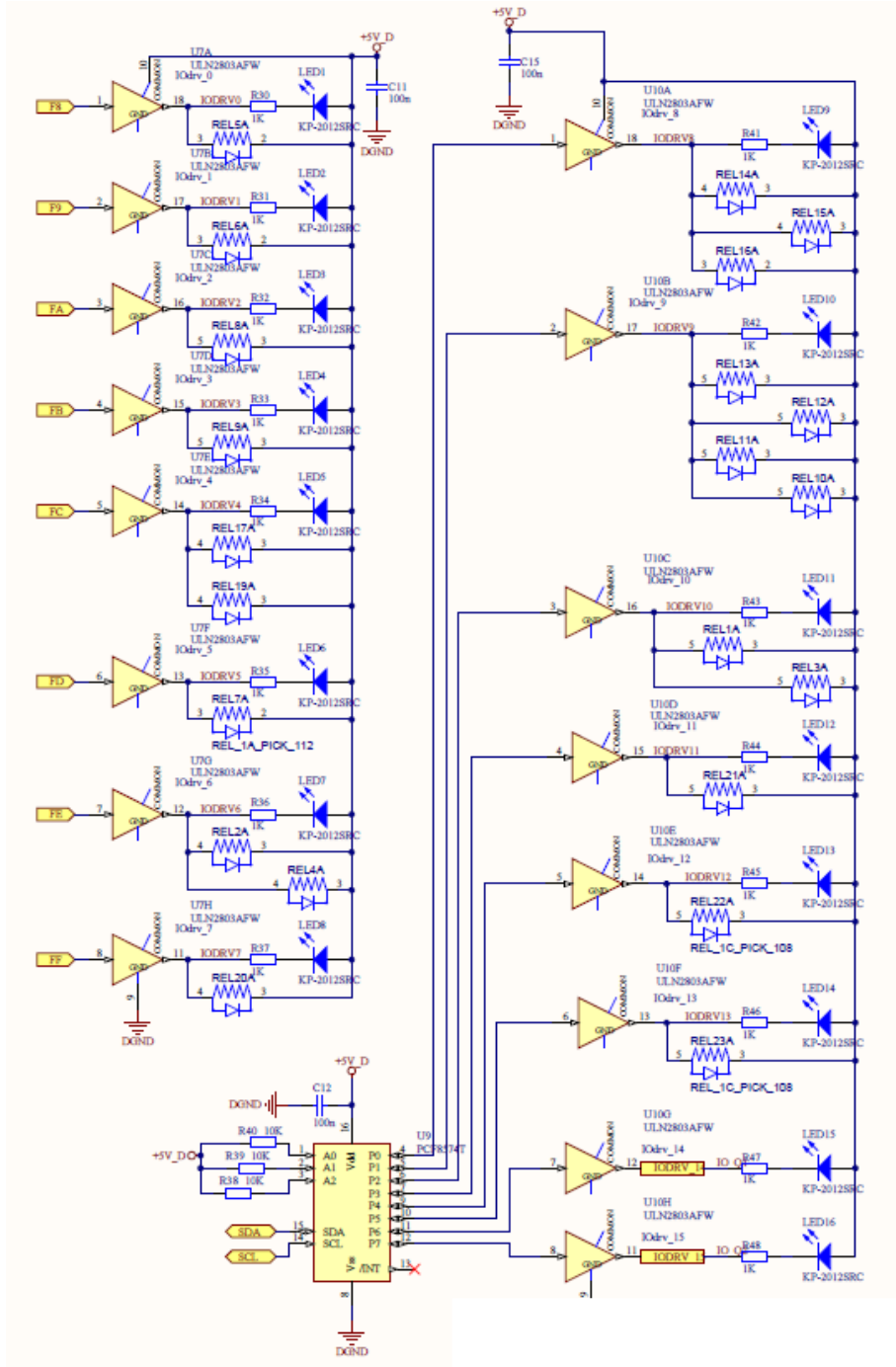

Figure 12: Relays Block



### 1.3. Daughter board Connectors

The main board has two connectors to the interface with the application. The PTC allows adding a full PCB in between. This daughter board can be mounted on the two connectors. In some exceptional cases, a daughter board contains only a few wires from the Analog connector to the application connector. The pins on of the connectors are described below.

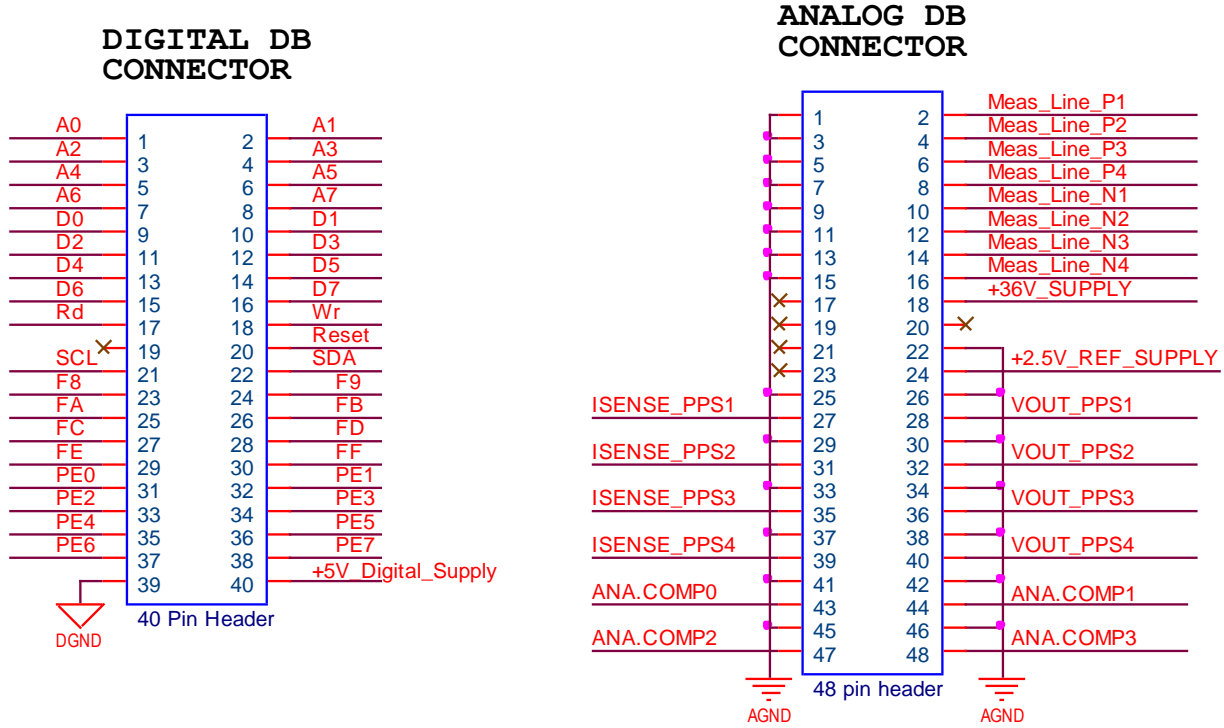

Figure 13: Daughter Board Connectors

### 1.3.1. Digital DB Connector (40 Pins)

Mainly, the digital connector is meant to expand the programmer to extra needs. Address lines A0-A7 together with the Map Select Lines F8-FF allows to direct access an area of 2 K. Examples would be adding a simple addressed I/O register by using the selection lines. If more complexity is needed, a full FPGA can be mounted on the DB board

Pins	Names	Description
1 – 8	A0 – A7	Address lines
9 – 16	D0 – D7	Data Lines active during Rd or Wr signals
17	Rd	Read: A negative pulse will indicate a sampling of the data on the Data Bus
18	Wr	Write: A Negative pulse will indicate when data is available on the Data Bus
20	Reset	This signal goes low by powering the PTC or by pressing the reset button. This line can be pulled low by application. Check firmware documentation for resetting by software.
21-22	SCL / SDA	I2c Bus
23-30	F8,F9,...,FF	CS lines when the address areas are accessed
31-38	Port E	Note: These pins are limited to 5 Volt input\output!!!! The full Port E of the Atmega core is mounted to these pins. This allows us to use advanced features like PWM, UARTS, Time Measurements, etc.... By using firmware that supports these, functions, application specific requirements can be fulfilled.
39	DGND	Digital Ground
40	+5V Digital	5 Volt Digital Supply. Maximum current to get out of this supply: 250mA

*Note: All the pins are limited to 5 Volt input\output!!!! However, there are Protections, please take precautions in order to avoid damage of the main board.*

### 1.3.2. Analog DB Connector (48 Pins)

Mainly, the analog connector provides all the analog signals and measure possibilities.

Pins	Names	Description
28,32,36	PPS 1-3	Output of the Programmable Supplies
40	PPS 4	Output of the Fast DAC Programmable Power Supply
27,31,35,39	Isense_PP1-4	Outputs (Driver outputs before Rsens) for current evaluations. These outputs could be used to connect to the analog comparators in order to create fast digital signals based on current.
2,4,6,8	ExtMeas1-4Pos	There are 4 differential inputs for making measurements
10,12,14,16	ExtMeas1_4Neg	The negative inputs of ExtMeas1-4Pos
17,19,21,23	Shtd_PPS1-4	Outputs that shows the status of the Drivers. Signals are meant to connect LED's to put the front panel
43,44,47,48	AnaComp0-3	Input (limited to 5V) See *Note. Fast Level comparators in order to remove time consuming measurement
18	+35V_Supply	Supply to extend the daughter board with some extra drivers
24	+2.5V Ref	Output of internal reference
All other	AGND	Analog Ground

*Note: All the pins are limited to 35 Volt input\output!!!! However, there are Protections, please take precautions in order to avoid damage of the main board.*

*\* Note: Some pins are protected and limited to 5 Volt!!!! However, there are Protections, please take precautions in order to avoid damage of the main board.*

### 1.4. Application Connector

The figure and table below shows the connections as provided by the daughterboard PTC04-DB-HALL06. The view of the connector is front view for the female connector of the PTC04-DB-HALL06 which corresponds to the solder side of the male connector. The right side of the connector is used for device / die A, the left side of the connector is used for device / die B.

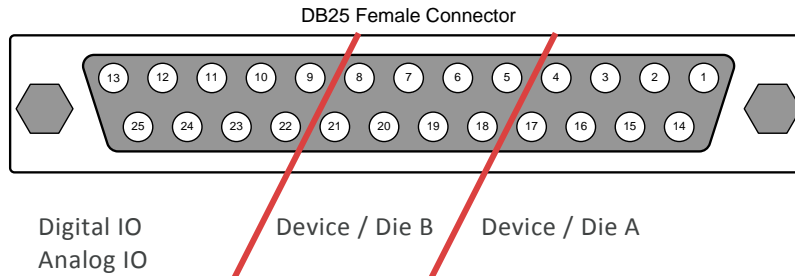

Additional, there are screw terminals on the Daughterboard that allows you to connect direct to wire.

PTC04				90371 90372 91372	
D-SUB 25				SO	TSSOP
Pin	Names	SPI	Description	Pin	Pin
1	VDDA	VDD	Supply Device A (Minimum required single die connection)	1	3
2	OUT1A	MOSI	Output 1 Device A (Minimum required single die connection)	5	15
3	OUT2A	MISO	Output 2 Device A		
4	VSSA	VSS	Analog Ground Device A (Minimum required single die connection)	8	2
5	VDDDB		Supply Device B (Minimum required dual die connection <sup>1</sup> )		11
6	OUT1B	SS1	Output 1 Device B (Minimum required dual die connection)		6
7	OUT2B	SS2	Output 2 Device B		
8	VSSB		Analog Ground Device B (Minimum required dual die connection)		10
9		CLK	SPI CLOCK		
10	V_BAT		Programmable power supply (Max 30mA load)		
11	M2S		Digital IO		
12	SCL		I2C communication		
13	+5Vdig		Digital supply used for I2C devices		
14	VDDA_S		Sensing Supply Device A	1	3
15	OUT1A_S		Sensing Output 1 Device A	5	15
16	OUT2A_S		Sensing Output 2 Device A		
17	VSSA_S		Sensing Analog Ground Device A	8	2
18	VDDDB_S		Sensing Supply Device B		11
19	OUT1B_S		Sensing Output 1 Device B		6
20	OUT2B_S		Sensing Output 2 Device B		
21	VSSB_S		Sensing Analog Ground Device B		10
22	DB_TEST		Free measuring line		
23	S2M		Digital IO		
24	SDA		I2C communication		
25	DGND		Digital ground for I2C communication		
MH	AGND		Metal Housing (shielding of the connector)		

<sup>1</sup> In case of a dual die connection with a common supply in the application (common VDD), only the VDDA pin of the daughter board device connector needs to be connected.

PTC04				90371	90372
				90372	
D-SUB 25				DMP#1	DMP#2
Pin	Names	SPI	Description	Pin	PIN
1	VDDA	VDD	Supply Device A (Minimum required single die connection)	2	3
2	OUT1A	MOSI	Output 1 Device A (Minimum required single die connection)	3	1
3	OUT2A	MISO	Output 2 Device A		
4	VSSA	VSS	Analog Ground Device A (Minimum required single die connection)	4	2
5	VDDDB		Supply Device B (Minimum required dual die connection <sup>2</sup> )		
6	OUT1B	SS1	Output 1 Device B (Minimum required dual die connection)		
7	OUT2B	SS2	Output 2 Device B		
8	VSSB		Analog Ground Device B (Minimum required dual die connection)		
9		CLK	SPI CLOCK		
10	V_BAT		Programmable power supply (Max 30mA load)		
11	M2S		Digital IO		
12	SCL		I2C communication		
13	+5Vdig		Digital supply used for I2C devices		
14	VDDA_S		Sensing Supply Device A	2	3
15	OUT1A_S		Sensing Output 1 Device A	3	1
16	OUT2A_S		Sensing Output 2 Device A		
17	VSSA_S		Sensing Analog Ground Device A	4	2
18	VDDDB_S		Sensing Supply Device B		
19	OUT1B_S		Sensing Output 1 Device B		
20	OUT2B_S		Sensing Output 2 Device B		
21	VSSB_S		Sensing Analog Ground Device B		
22	DB_TEST		Free measuring line		
23	S2M		Digital IO		
24	SDA		I2C communication		
25	DGND		Digital ground for I2C communication		
MH	AGND		Metal Housing (shielding of the connector)		

<sup>2</sup> In case of a dual die connection with a common supply in the application (common VDD), only the VDDA pin of the daughter board device connector needs to be connected.

PTC04				90373	
D-SUB 25				DMP	TSSOP
Pin	Names	SPI	Description	Pin	Pin
1	VDDA	VDD	Supply Device A (Minimum required single die connection)	2	3
2	OUT1A	MOSI	Output 1 Device A (Minimum required single die connection)		
3	OUT2A	MISO	Output 2 Device A		
4	VSSA	VSS	Analog Ground Device A (Minimum required single die connection)	4	2
5	VDDDB		Supply Device B (Minimum required dual die connection <sup>3</sup> )		11
6	OUT1B	SS1	Output 1 Device B (Minimum required dual die connection)		
7	OUT2B	SS2	Output 2 Device B		
8	VSSB		Analog Ground Device B (Minimum required dual die connection)		10
9		CLK	SPI CLOCK		
10	V_BAT		Programmable power supply (Max 30mA load)		
11	M2S		Digital IO		
12	SCL		I2C communication		
13	+5Vdig		Digital supply used for I2C devices		
14	VDDA_S		Sensing Supply Device A	2	3
15	OUT1A_S		Sensing Output 1 Device A		
16	OUT2A_S		Sensing Output 2 Device A		
17	VSSA_S		Sensing Analog Ground Device A	4	2
18	VDDDB_S		Sensing Supply Device B		11
19	OUT1B_S		Sensing Output 1 Device B		
20	OUT2B_S		Sensing Output 2 Device B		
21	VSSB_S		Sensing Analog Ground Device B		10
22	DB_TEST		Free measuring line		
23	S2M		Digital IO		
24	SDA		I2C communication		
25	DGND		Digital ground for I2C communication		
MH	AGND		Metal Housing (shielding of the connector)		

<sup>3</sup> In case of a dual die connection with a common supply in the application (common VDD), only the VDDA pin of the daughter board device connector needs to be connected.

PTC04				90374		
D-SUB 25				DMP	SO	TSSOP
Pin	Names	SPI	Description	Pin	Pin	Pin
1	VDDA	VDD	Supply Device A (Minimum required single die connection)	3	1	3
2	OUT1A	MOSI	Output 1 Device A (Minimum required single die connection)	1	5	15
3	OUT2A	MISO	Output 2 Device A	4	3	13
4	VSSA	VSS	Analog Ground Device A (Minimum required single die connection)	2	8	2
5	VDDDB		Supply Device B (Minimum required dual die connection <sup>4</sup> )			11
6	OUT1B	SS1	Output 1 Device B (Minimum required dual die connection)			7
7	OUT2B	SS2	Output 2 Device B			5
8	VSSB		Analog Ground Device B (Minimum required dual die connection)			10
9		CLK	SPI CLOCK			
10	V_BAT		Programmable power supply (Max 30mA load)			
11	M2S		Digital IO			
12	SCL		I2C communication			
13	+5Vdig		Digital supply used for I2C devices			
14	VDDA_S		Sensing Supply Device A	3	1	3
15	OUT1A_S		Sensing Output 1 Device A	1	5	15
16	OUT2A_S		Sensing Output 2 Device A	4	3	13
17	VSSA_S		Sensing Analog Ground Device A	2	8	2
18	VDDDB_S		Sensing Supply Device B			11
19	OUT1B_S		Sensing Output 1 Device B			7
20	OUT2B_S		Sensing Output 2 Device B			5
21	VSSB_S		Sensing Analog Ground Device B			10
22	DB_TEST		Free measuring line			
23	S2M		Digital IO			
24	SDA		I2C communication			
25	DGND		Digital ground for I2C communication			
MH	AGND		Metal Housing (shielding of the connector)			

<sup>4</sup> In case of a dual die connection with a common supply in the application (common VDD), only the VDDA pin of the daughter board device connector needs to be connected.

PTC04				90380		
D-SUB 25				DMP	SO	TSSOP
Pin	Names	SPI	Description	Pin	Pin	Pin
1	VDDA	VDD	Supply Device A (Minimum required single die connection)	2	6/7	14/15
2	OUT1A	MOSI	Output 1 Device A (Minimum required single die connection)	3	8	16
3	OUT2A	MISO	Output 2 Device A	1	5	13
4	VSSA	VSS	Analog Ground Device A (Minimum required single die connection)	4	1	1
5	VDDDB		Supply Device B (Minimum required dual die connection <sup>5</sup> )			6/7
6	OUT1B	SS1	Output 1 Device B (Minimum required dual die connection)			8
7	OUT2B	SS2	Output 2 Device B			5
8	VSSB		Analog Ground Device B (Minimum required dual die connection)			9
9		CLK	SPI CLOCK			
10	V_BAT		Programmable power supply (Max 30mA load)			
11	M2S		Digital IO			
12	SCL		I2C communication			
13	+5Vdig		Digital supply used for I2C devices			
14	VDDA_S		Sensing Supply Device A	2	6/7	14/15
15	OUT1A_S		Sensing Output 1 Device A	3	8	16
16	OUT2A_S		Sensing Output 2 Device A	1	5	13
17	VSSA_S		Sensing Analog Ground Device A	4	1	1
18	VDDDB_S		Sensing Supply Device B			6/7
19	OUT1B_S		Sensing Output 1 Device B			8
20	OUT2B_S		Sensing Output 2 Device B			5
21	VSSB_S		Sensing Analog Ground Device B			9
22	DB_TEST		Free measuring line			
23	S2M		Digital IO			
24	SDA		I2C communication			
25	DGND		Digital ground for I2C communication			
MH	AGND		Metal Housing (shielding of the connector)			

<sup>5</sup> In case of a dual die connection with a common supply in the application (common VDD), only the VDDA pin of the daughter board device connector needs to be connected.

## 1.5. Jumper Selection

### 1.5.1. CON18 and CON19 – short measuring lines

The D-SUP DB-25 connector of the daughter board is equipped with a sensing line for each analog device pin.

The top row is the force line of the device pins. The bottom row is the sensing line of the device pins.

Between each force and sense line there is a jumper to short the sense line at the DB-25 connector on the daughter board.

The jumper is placed when the external sensing is not required. For example: an application with a digital or PWM output.

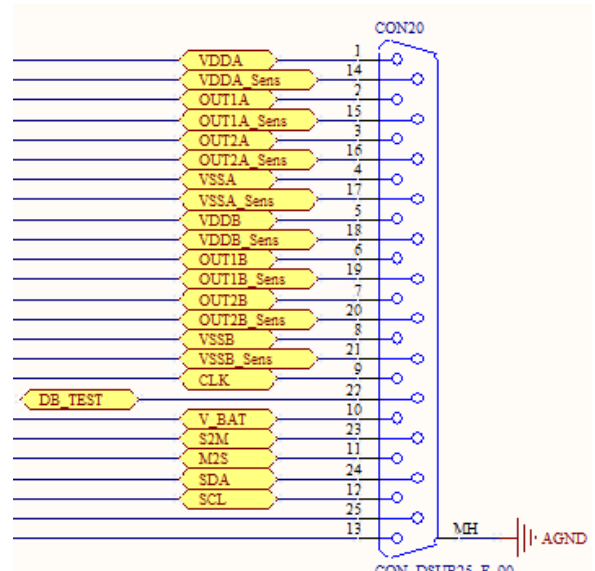

Figure 15: DB-25 device connector.



Figure 14: Jumper between force and sense line.

#### Single wire connection



When the jumper is closed, only one wire is required **per pin** between the PTC-04 and the module or sensor.

In the table above these pins are marked as “Minimum required single/dual die connection”.

In this configuration the measurement of VDD, OUT1 or OUT2 is done at the D-SUB DB-25 connector of the PTC04-DB-HALL06.

#### Double wire connection



When the jumper is open, two wires are required **per pin** between the PTC-04 and the module or sensor.

With two wires connected at the module side, the measurement of VDD, OUT1 or OUT2 is done on the module or sensor.

The external sensing line per pin is only required for applications with an analog sensor output and where a higher measuring accuracy is required.



### 1.5.2. J2, J3, J4 and J5 – select pull-up

These jumpers are used to select the pull-up resistor for the outputs of die A and B:

- JP2: Pull-up selection for OUT1 die A
- JP3: Pull-up selection for OUT2 die A
- JP4: Pull-up selection for OUT1 die B
- JP5: Pull-up selection for OUT2 die B

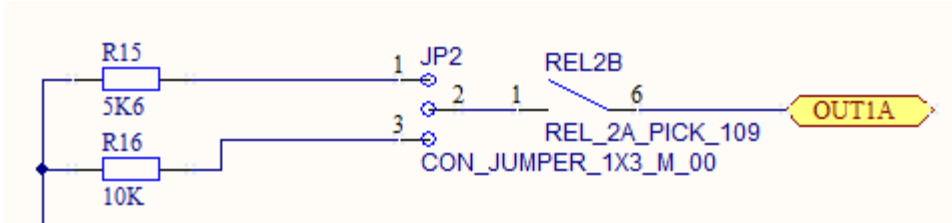

Place the jumper between:

- Pin 1 and 2 → select 5K6 Pull-up
- Pin 3 and 2 → select 10K Pull-up

The selection between VDD and Vbat is done by a relay on software level. When Vbat is set to 0V one can select a pull-down

### 1.5.3. CON3 and CON21 – configure MUPeT circuit

The MUPeT circuit on the daughter board is used to convert the clock and data of the UART to a single wire protocol called MUPeT.

CON3 and CON21 are used to configure the resistors of the MUPeT circuit in function of the output resistance on the sensor/module.



- Pin 1 and 2 → select 100Ω
- Pin 3 and 4 → select digital potentiometer

## 2. Contact

For the latest version of this document, go to our website at [www.melexis.com](http://www.melexis.com).

For additional information, please contact our Direct Sales team and get help for your specific needs:

Europe, Africa	Telephone: +32 13 67 04 95
	Email : <a href="mailto:sales_europe@melexis.com">sales_europe@melexis.com</a>
Americas	Telephone: +1 603 223 2362
	Email : <a href="mailto:sales_usa@melexis.com">sales_usa@melexis.com</a>
Asia	Email : <a href="mailto:sales_asia@melexis.com">sales_asia@melexis.com</a>

## 3. Disclaimer

*The information furnished by Melexis herein ("Information") is believed to be correct and accurate. Melexis disclaims (i) any and all liability in connection with or arising out of the furnishing, performance or use of the technical data or use of the product(s) as described herein ("Product") (ii) any and all liability, including without limitation, special, consequential or incidental damages, and (iii) any and all warranties, express, statutory, implied, or by description, including warranties of fitness for particular purpose, non-infringement and merchantability. No obligation or liability shall arise or flow out of Melexis' rendering of technical or other services.*

*The Information is provided "as is" and Melexis reserves the right to change the Information at any time and without notice. Therefore, before placing orders and/or prior to designing the Product into a system, users or any third party should obtain the latest version of the relevant information to verify that the information being relied upon is current.*

*Users or any third party must further determine the suitability of the Product for its application, including the level of reliability required and determine whether it is fit for a particular purpose.*

*The Information is proprietary and/or confidential information of Melexis and the use thereof or anything described by the Information does not grant, explicitly or implicitly, to any party any patent rights, licenses, or any other intellectual property rights.*

*This document as well as the Product(s) may be subject to export control regulations. Please be aware that export might require a prior authorization from competent authorities.*

*The Product(s) are intended for use in normal commercial applications. Unless otherwise agreed upon in writing, the Product(s) are not designed, authorized or warranted to be suitable in applications requiring extended temperature range and/or unusual environmental requirements. High reliability applications, such as medical life-support or life-sustaining equipment are specifically not recommended by Melexis.*

*The Product(s) may not be used for the following applications subject to export control regulations: the development, production, processing, operation, maintenance, storage, recognition or proliferation of 1) chemical, biological or nuclear weapons, or for the development, production, maintenance or storage of missiles for such weapons; 2) civil firearms, including spare parts or ammunition for such arms; 3) defense related products, or other material for military use or for law enforcement; 4) any applications that, alone or in combination with other goods, substances or organisms could cause serious harm to persons or goods and that can be used as a means of violence in an armed conflict or any similar violent situation.*

*The Products sold by Melexis are subject to the terms and conditions as specified in the Terms of Sale, which can be found at <https://www.melexis.com/en/legal/terms-and-conditions>.*

*This document supersedes and replaces all prior information regarding the Product(s) and/or previous versions of this document.*

*Melexis NV © - No part of this document may be reproduced without the prior written consent of Melexis. (2018)*

*ISO/TS 16949 and ISO14001 Certified*

## X-ON Electronics

Largest Supplier of Electrical and Electronic Components

*Click to view similar products for [Multiple Function Sensor Development Tools](#) category:*

*Click to view products by [Melexis](#) manufacturer:*

Other Similar products are found below :

[RD-KL25-AGMP01](#) [PTC-04-DB-ACT](#) [PTC-04-DB-FL](#) [FRDM-K22F-SA9500](#) [EV\\_ICM-20649](#) [MULTI-SENSE-GEVB](#) [BRKT-STBC-SA9500](#) [3397](#) [STEVAL-MKIT01V1](#) [EVAL-CN0411-ARDZ](#) [SEN0004](#) [KT-TVOC-200-TB200A](#) [KT-NmHc-200-TB200A](#) [SEN0344](#) [PIM520](#) [PIM518](#) [PIM519](#) [PIM510](#) [103030375](#) [ZSSC4132KIT](#) [ADIS16505-3/PCBZ](#) [SEN-16794](#) [PIM502](#) [SEN0359](#) [4829](#) [EV26Q64A](#) [EVAL-AD7746RDZ](#) [EVAL-AD7746HDZ](#) [AS7022-EVALKIT](#) [RTK0ESXB10C00001BJ](#) [MAX30134EVSYS#](#) [EV-CBM-PIONEER1-1Z](#) [EVAL-ADPD188BIZ-S2](#) [EVAL-ADCM-1](#) [EVAL-CN0507-ARDZ](#) [SI118X-KIT](#) [ALTEHTG2SMIP](#) [EVAL-CN0533-EBZ](#) [MIKROE-4305](#) [MAX30101WING#](#) [MIKROE-4192](#) [MIKROE-4049](#) [OB1203SD-U-EVK](#) [OB1203SD-BT-EVK](#) [MIKROE-4037](#) [101990644](#) [MIKROE-4267](#) [MIKROE-4330](#) [ARG-LDKT](#) [EVAL-CN0503-ARDZ](#)