

1. Features and Benefits

- Integrated High sensitivity Hall Sensor
- No VDD concept
- Locked rotor protection and auto-restart
- Power-efficient CMOS and power MOSFETs
- Built-in output protection clamping diode
- Integrated tachometer (FG: US90A) or alarm (RD: US91A) signal output
- FG/RD SIP package options:
 - 4 pins VA and VK package
- SMD package options
 - SOIC8 bent leads
 - SOT25 straight leads
- RoHS Compliant
- Peak current up to 500mA

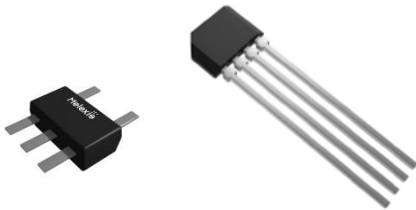

2. Application Examples

- 12V and 24V 2-coil fans

3. Description

The US90A/91A is a one-chip solution for driving two-coil brushless DC cooling fans.

Based on the advanced Melexis CMOS process, the IC contains a Hall-effect sensor, dynamic offset correction and low side output drivers.

Frequency Generator or Rotation Detection is available. The open-drain output makes the connectivity with any external interface such as hardware monitoring or Super I/O IC easier.

These features are combined with the Melexis patented no-VDD design to fit the IC in small 4-pin VK and VA package. The device is also delivered in DC package for automatic assembly.

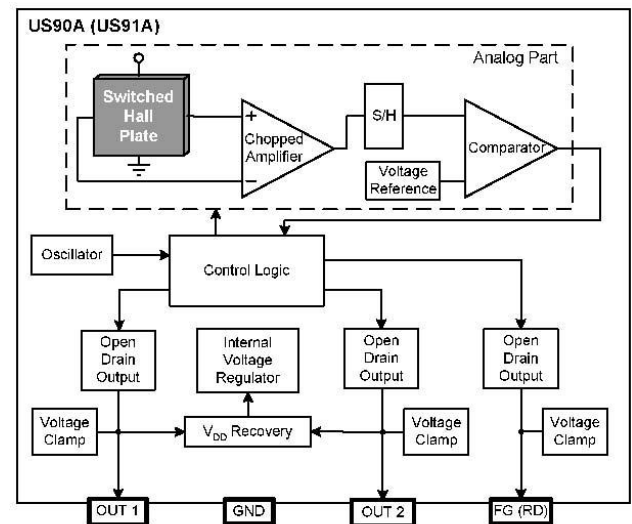

Figure 1

Contents

1. Features and Benefits.....	1
2. Application Examples.....	1
3. Description	1
4. Ordering Information	3
5. Glossary of Terms.....	4
6. Pin Definitions and Descriptions	4
7. Electrical Specifications	5
7.1. Absolute Maximum Ratings	5
7.2. General Electrical Specifications	5
7.3. Magnetic Specifications.....	6
7.4. Driver output vs Magnetic pole	6
8. Description	7
8.1. General description	7
8.2. No-VDD concept	7
8.3. LRP	7
9. Performance Graphs.....	8
10. Application Information.....	9
11. Package Information.....	10
11.1. VK Package Information (4-pin TO92)	10
11.2. Trimmed VK T&R(dead bug) : VKAAA000-RX	10
11.2.1. VKAA000-RX Tape	11
11.2.2. VKAAA000-RX Lead Trim length.....	11
11.3. DC Package Information (8-pin narrow SOIC)	11
11.4. VA Package Information (4-pin TO92 flat).....	12
11.5. ZE Package (SOT25 with straight leads).....	14
12. Standard Information	14
13. ESD Precautions.....	15
14. Disclaimer.....	15
15. Revision History Table	16
16. Contact.....	16

4. Ordering Information

Product	Temperature	Package	Option Code	Packing Form	Description
US90A	E	DC	AAA-000	RX	FG (frequency output)
US91A	E	DC	AAA-000	RX	RD (alarm output)
US90A	E	VK	AAA-000	BU	FG (frequency output)
US90A	E	VK	AAA-000	RX	VK cut leads in T&R FG (frequency output)
US91A	E	VK	AAA-000	BU	RD (alarm output)
US91A	E	VK	AAA-000	RX	VK cut leads in T&R RD (alarm output)
US90A	E	VA	AAA-000	BU	FG (frequency output)
US91A	E	VA	AAA-000	BU	RD (alarm output)
US90A	E	ZE	AAA-000	RE	FG (frequency output)
US91A	E	ZE	AAA-000	RE	RD (alarm output)

Legend:

Package Code:	<p>“DC” for SOIC-8 package</p> <p>“VK” for Plastic Single in Line thickness 1.5 - 1.6mm</p> <p>“VA” for Plastic Single in Line thickness 1.1 -1.2mm</p> <p>“ZE” for straight leads SOT25</p>
Packing Form:	<p>“RE for Reel, live bug (die face up)”</p> <p>“RX for Reel, dead bug (die face down)”</p> <p>“BU for Bulk bag”</p>
Ordering Example:	<p>“US91AEZE AAA000-RE”</p> <p>For an RD output in straight leads SOT25 package, delivered in Reel.</p>

Table 1

5. Glossary of Terms

Gauss (G), Tesla (T)	Units for the magnetic flux density – 1 mT = 10 G
NC	Not Connected
Two-coil fan	A fan with two-coil windings where current alternates from 1 coil to the other depending on the direction of the magnetic field.
MilliTesla (mT), Gauss	Units of magnetic flux density: 1mT = 10 Gauss
VDD	Voltage on the coils common node.
IDD	Current supplying the chip which flows through the coil connected to the switched off output driver.
Peak output current	The current flowing in the coil at start-up, only limited by the coil resistance RCOIL and the output driver resistance RDSON.
Continuous output current	The current flowing in the coil when the fan is spinning normally
Locked rotor	The state when the fan stopped spinning due to mechanical blockage.
FG	Frequency generator or tachometer output
RD	Rotation detection or alarm output
LFPM	Linear Feet Per Minute – Unit of airflow velocity

Table 2

6. Pin Definitions and Descriptions

Name	SOIC8 Pin #	SOT25 Pin #	VK Pin #	VA Pin #	Description
FG (RD)	1	4	1	1	open drain output signal
OUT1	2	3	2	2	Open Drain Coil Driver 1
OUT2	3	1	3	4	Open Drain Coil Driver 2
GND	4	2	4	3	Ground pin
N.C.	5,6,7,8	5			Not Connected

Table 3

For optimal EMC behavior connect the unused pins (Not Used) to the Ground.

7. Electrical Specifications

7.1. Absolute Maximum Ratings

Parameter	Symbol	Value	Units
Fan Supply Voltage	VDD	30	V
Maximum voltage OUT1, OUT2	Vout	100	V
Peak Output Current	IOUTp	500	mA
Continuous Output Current	IOUTc	250	mA
FG / RD Output Current	IFG (RD)	20	mA
Junction Temperature	TJ	-40 to 125	°C
Storage Temperature Range	TS	-55 to 150	°C
Magnetic Flux Density	B	Unlimited	mT
ESD HBM	ESDhbm	4000	V

Table 4

Exceeding the absolute maximum ratings may cause permanent damage. Exposure to absolute maximum-rated conditions for extended periods may affect device reliability.

7.2. General Electrical Specifications

DC Operating Parameters $T_A = 25^\circ\text{C}$, $V_{DD} = 24\text{V}$ (unless otherwise specified)

Parameter	Symbol	Test Conditions	Min	Typ	Max	Units
Fan Supply Voltage	VDD	Operating, RCOIL = 50Ω	4.7 ⁽¹⁾		30	V
Supply Current	IDD			2	4	mA
Output Saturation Voltage	VDSON	IOUT = 150mA		375		mV
Output Saturation Voltage	VDSON	IOUT = 250mA		625		mV
Output Clamp Voltage	VOUT		60		80	V
FG / RD Output Low Voltage	VOL	IOL = 10mA		250	500	mV
FG / RD Output Clamp Voltage	VCLAMP		28			V

Parameter	Symbol	Test Conditions	Min	Typ	Max	Units
FG / RD Output Leakage Current	ILEAK	VFG (VRD) = 18V			10	uA
Locked rotor ON time	Ton		210		350	ms
Locke rotor OFF time	Toff	Auto restart after locked rotor shut down		6.3*Ton		
DC Thermal Resistance	RTHja ⁽²⁾			150		°C/Watt
VK Thermal Resistance	RTHja ⁽²⁾			200		°C/Watt
VA Thermal Resistance	RTHja ⁽²⁾			170		°C/Watt
ZE Thermal Resistance	RTHja ⁽²⁾			170		°C/Watt
ZE Thermal Resistance	RTHjc	Junction to package top		20		°C/Watt

Table 5

Note 1: The minimal value of VDD should be determined using the following equation: $V_{DD} = 4.5V + R_{COIL} * I_{DD}$
Note 2: Rthja for JEDEC single layer board 76.2 x 114.3 x 1.60, zero LFPM

7.3. Magnetic Specifications

DC Operating Parameters T_A = 25 °C, V_{DD} = 24V (unless otherwise specified)

Parameter	Symbol	Test Conditions	Min	Typ	Max	Units
Operate point	BOP			3	6	mT
Release point	BRP		6	3		mT
Hysteresis	BHYST		2	6		mT

Table 6 magnetic specification

7.4. Driver output vs Magnetic pole

Parameter	Test Conditions	OUT1	OUT2
North pole	B < Brp – all packages	High	Low
South pole	B > Bop all packages	Low	High

Table 7: Driver output vs. magnetic pole

Note: The magnetic pole is applied facing the branded side of the package

8. Description

8.1. General description

The US90A/91A is a one-chip solution for driving two-coil brushless DC fans. Based on advanced Melexis CMOS process, the IC contains a Hall-effect sensor, dynamic offset correction and low side output drivers.

The output drivers OUT1 and OUT2 are fully protected against switching transients. So there is no need for an external zener diode to cut the high voltage spikes induced by the fan coils.

The US90A has an open-drain integrated tachometer FG output that follows the Hall signal. In the US91A, the open-drain rotation detection output RD is active low during normal spinning of the motor. It goes high when the flux switching frequency becomes too low, which means the motor is blocked.

8.2. No-VDD concept

The absence of a V_{DD} pin enables the two low side output drivers and FG/RD signal output to fit in a four-pin VK package. The lack of a V_{DD} pin decreases also the probability to damage the chip due to reverse voltage connection, using the coil resistance to limit the reverse current. In this condition, the total reverse current is twice the peak current value of the fan used.

8.3. LRP

The built-in locked-rotor protection will automatically shut off the coil current when the rotor is mechanically blocked, or the rotational speed drops below 60 RPM (4-pole rotor magnet). The fan will try to restart every 1.5 seconds until the obstruction is clear. The On / Off cycling reduces the average stall current to 1/7 normal; this is enough to prevent overheating or damage to most fans. Both the US90A and US91A have this feature.

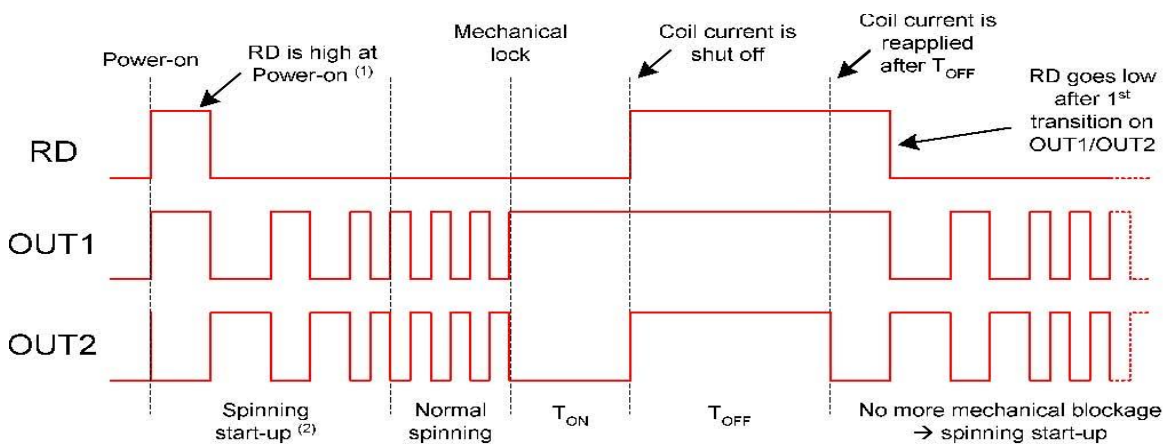

Note 1 : At Power-on, RD is high until the 1st transition on OUT1/OUT2.

Note 2 : The spinning start-up is the ramp between the zero speed and maximal speed. It depends on the motor characteristics.

Note 3 : This graph does not represent the EMF effect.

9. Performance Graphs

11.1 $R_{DS(on)}$ vs T_J

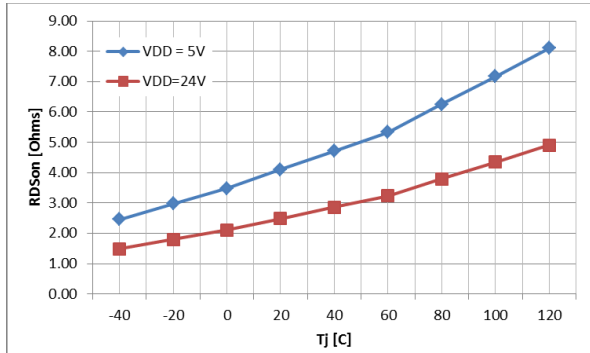

11.2 $R_{DS(on)}$ vs V_{DD}

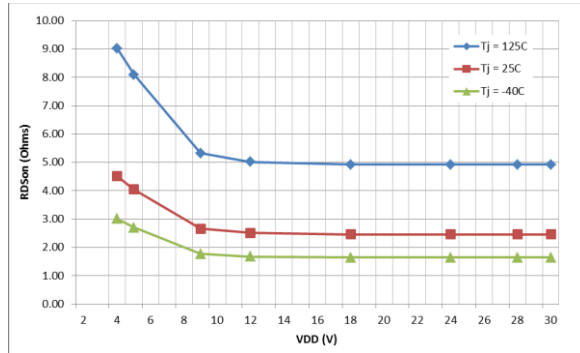

11.3 Magnetic parameters vs T_J

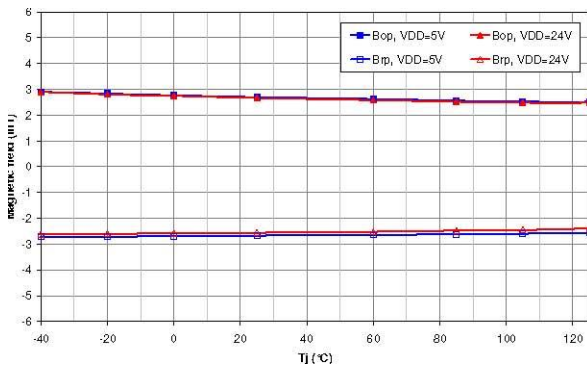

11.4 Magnetic parameters vs V_{DD}

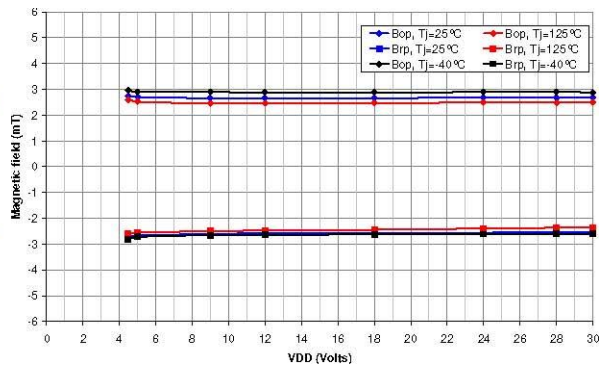

11.5 I_{DD} vs T_J

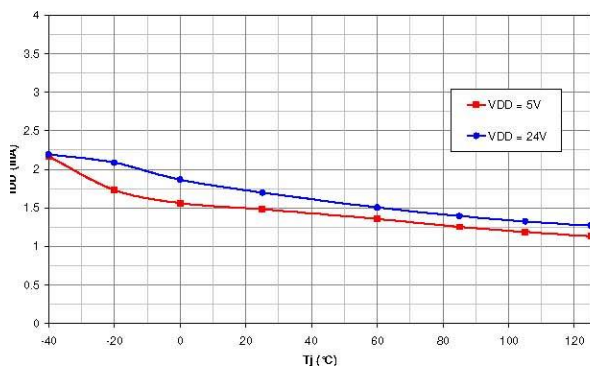

11.6 I_{DD} vs V_{DD}

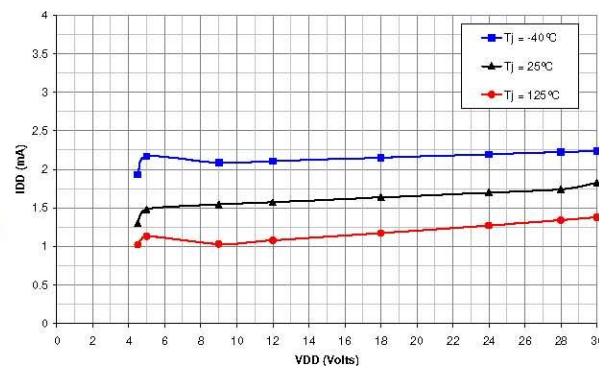

11.7 V_{OL} vs T_J

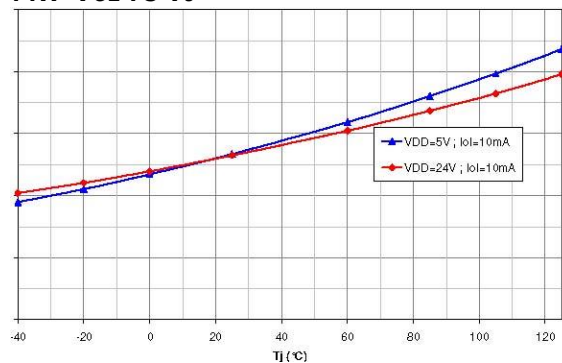

11.8 Power Dissipation vs. T_A

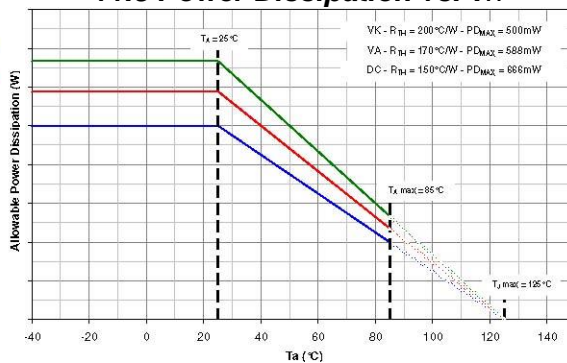

10. Application Information

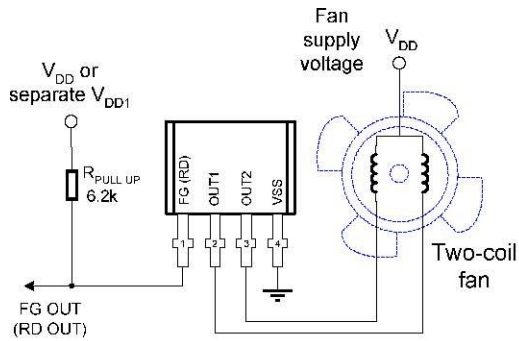

Typical application with pull-up resistor

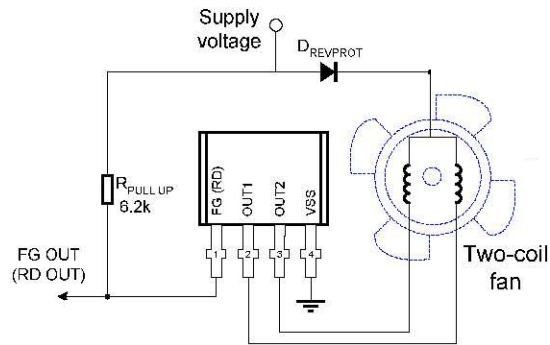

Configuration for reverse voltage protection

The left schematic shows an application including several external protections.

The diode DREVPROT best protects the chip and fan coils for reverse voltage condition.

The no-VDD design enables ESD protection at fan module level to be easily improved. The fan coils prevent and filter fast current stress on OUT1 and OUT2, resulting in better ESD protection.

11. Package Information

11.1. VK Package Information (4-pin TO92)

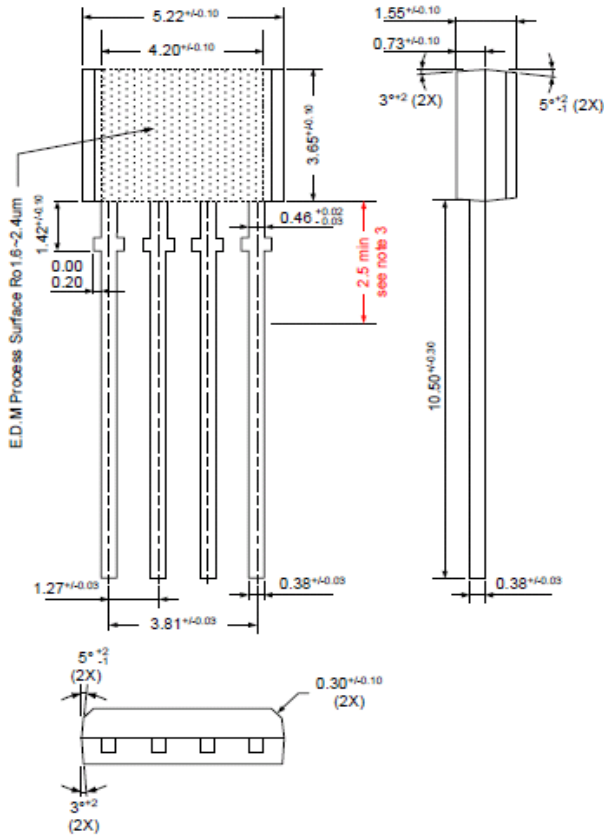

Notes:

1. All dimensions are in millimeters
2. Package dimension exclude molding flash. Mold flash shall not exceed 0.127mm.
3. To preserve reliability, it is recommended to have total lead length equal to 2.5mm minimum, measured from the package line.
4. VK package is a pin through-hole package, hence adapted for wave soldering process. A reflow soldering process is not recommended with VK package as it may seriously affect device reliability.

Marking:

- 1st Line : US90A (US91A) - Name of the device
- 2nd Line : xxxx - Assembly lot number (4 last digits)

Hall plate location

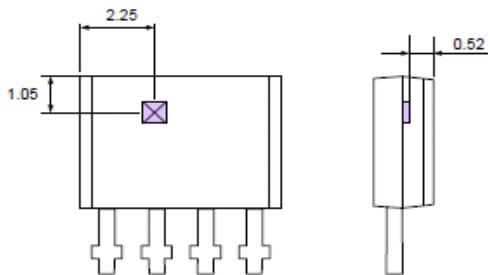

Notes:

1. All dimensions are in millimeters
2. Typical values

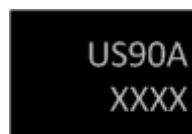

VK front marking

11.2. Trimmed VK T&R(dead bug) : VKAAA000-RX

11.2.1. VKAA000-RX Tape

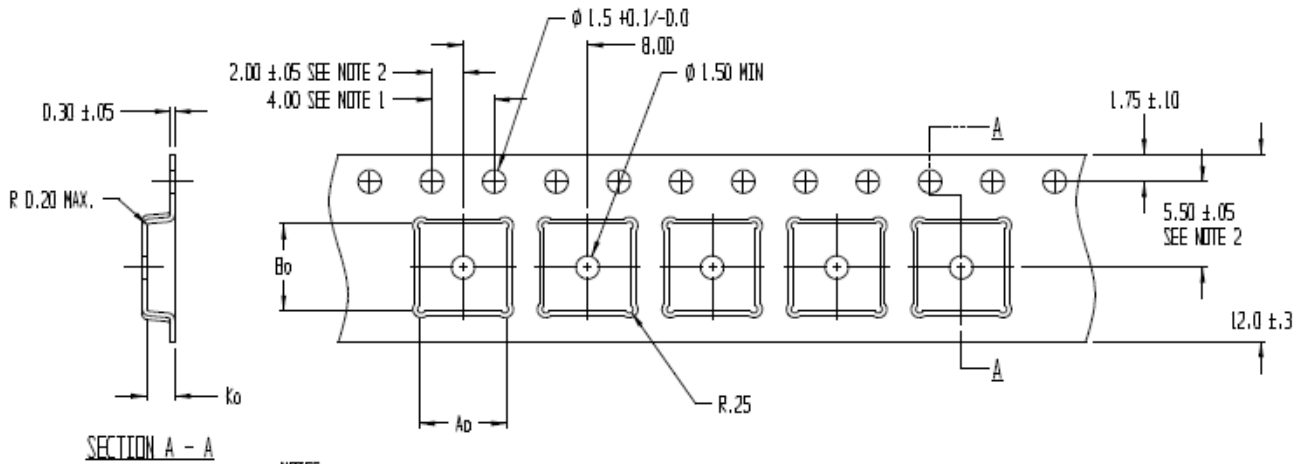

- NOTES:
1. 10 SPROCKET HOLE PITCH CUMULATIVE TOLERANCE ± 0.2
 2. POCKET POSITION RELATIVE TO SPROCKET HOLE MEASURED AS TRUE POSITION OF POCKET, NOT POCKET HOLE
 3. A_0 AND B_0 ARE CALCULATED ON A PLANE AT A DISTANCE "R" ABOVE THE BOTTOM OF THE POCKET.
- | |
|--------------|
| $A_0 = 5.60$ |
| $B_0 = 5.60$ |
| $K_0 = 1.83$ |

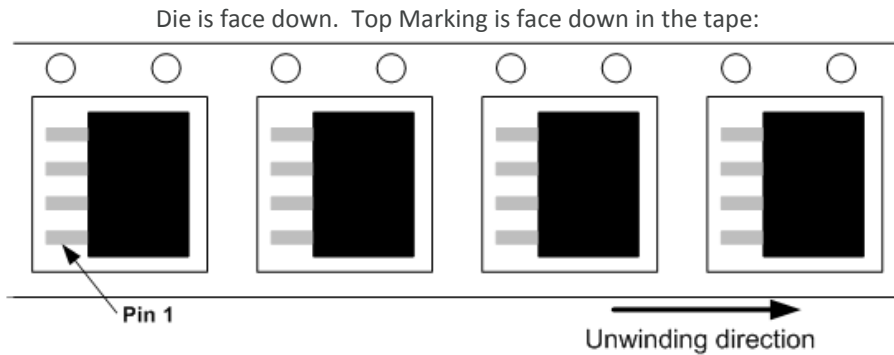

11.2.2. VKAAA000-RX Lead Trim length

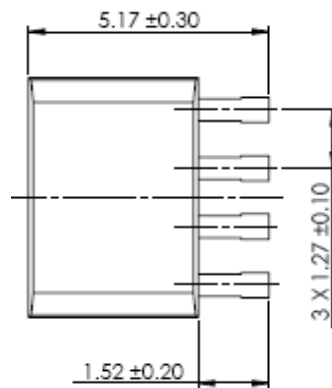

11.3. DC Package Information (8-pin narrow SOIC)

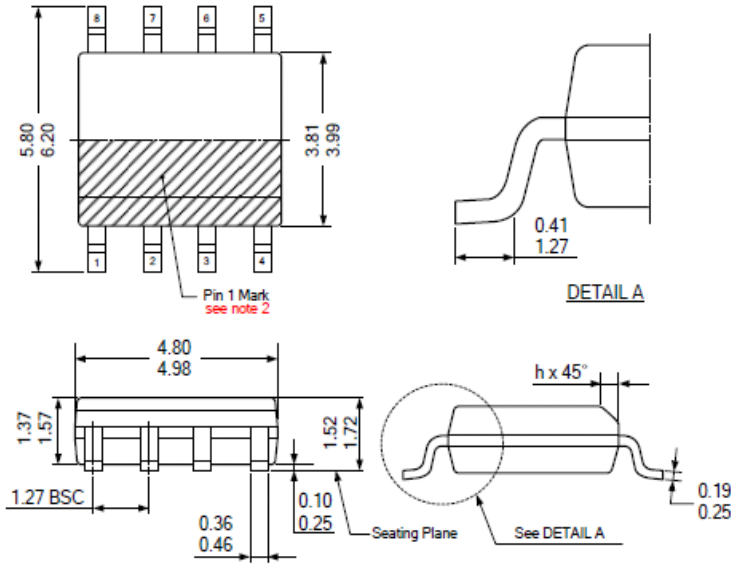

- Notes:**
1. Controlling dimensions in millimeters
 2. Detail of pin #1 identifier are optional but must be located within the zone indicated.
 3. Lead coplanarity should be to 0.10mm max.
 4. All dimensions exclude mold flashes
End flash from the package body shall not exceed 0.25mm per side.

Marking:

	US90A	US91A
Top Side:		
1 st Line :	US90A	US91A
2 nd Line :	xxxxxxxx	xxxxxxxx
3 rd Line :	yyww	NA
Bottom Side:		
1 st Line :	US90A	US91A
2 nd Line :	xxxxxxxx	xxxxxx
3 rd Line :	yyww	yyww

yyww : yy = year, ww = week
xxxxxxxx : assembly lot#

Hall plate location

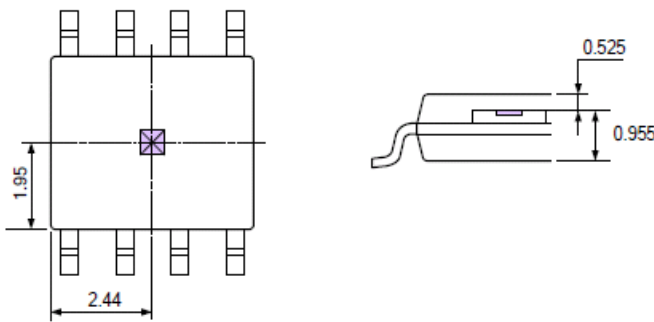

- Notes:**
1. All dimensions are in millimeters
 2. Typical values

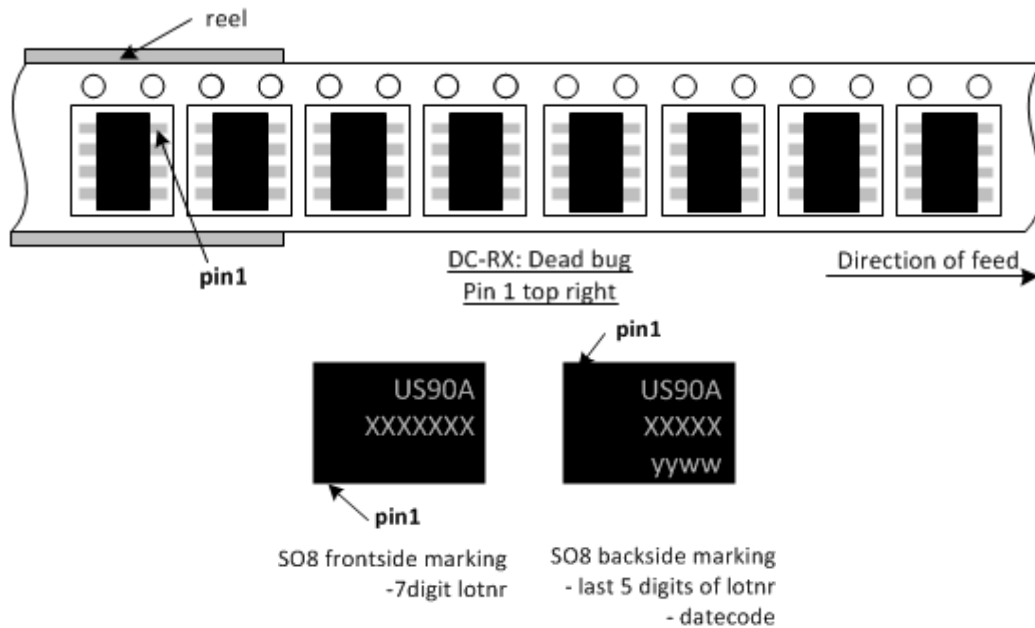

11.4. VA Package Information (4-pin TO92 flat)

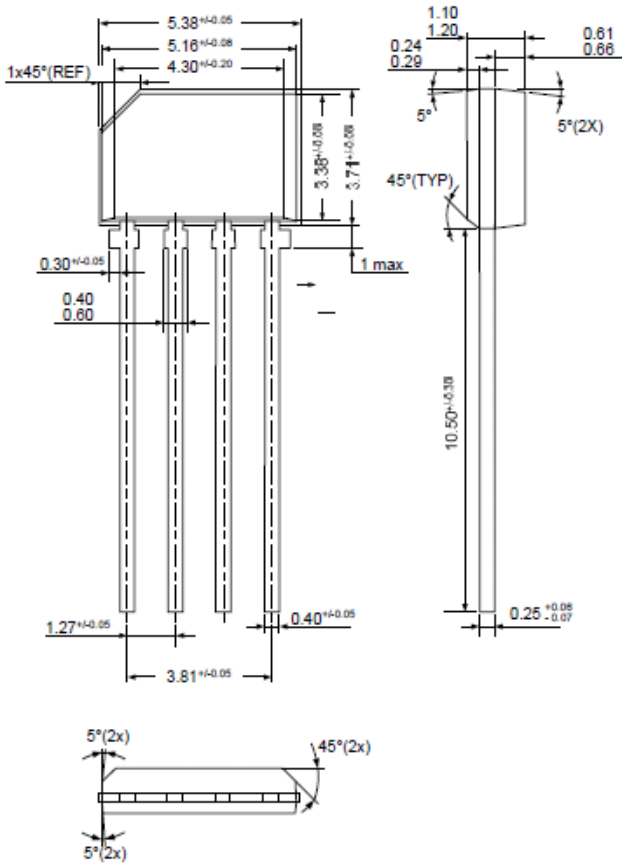

Notes:

1. All dimensions are in millimeters
2. Package dimension exclude end flash

Marking:

Top Side:

- 1st Line : US90A (US91A) - Name of the device
- 2nd Line : xxxxxx - Assembly lot number (last 6 digits)

Bottom Side:

- yyww : yy = year
- ww = week

Hall plate location

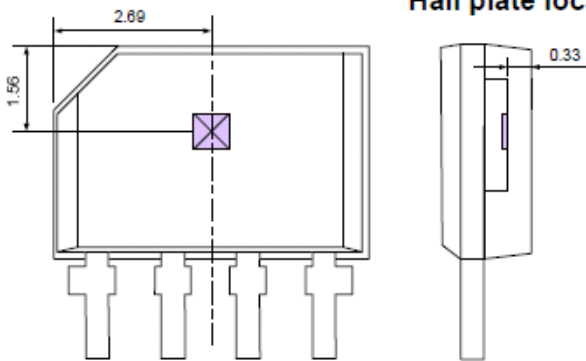

Notes:

1. All dimensions are in millimeters
2. Typical values



VA frontside marking



VA backside marking

11.5. ZE Package (SOT25 with straight leads)

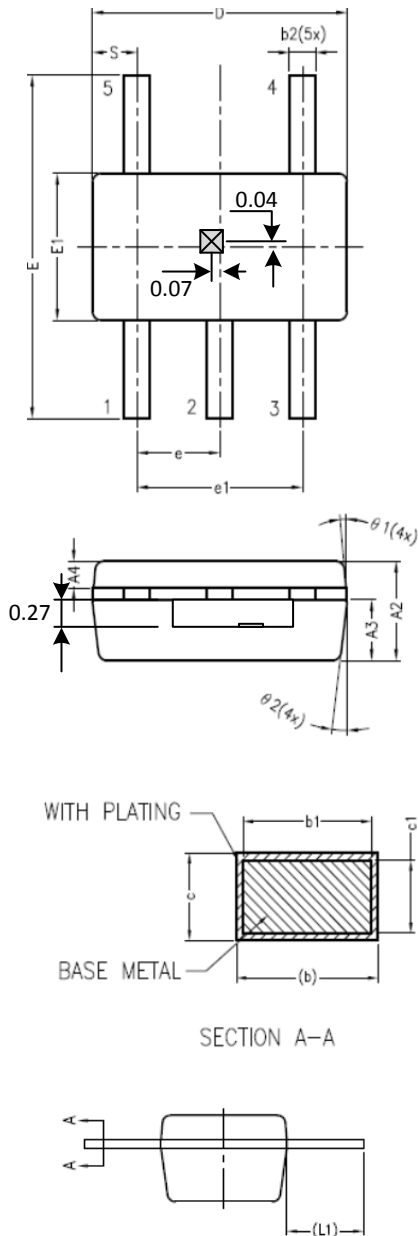

SYMBOLS	DIMENSIONS IN MILLIMETERS		
	MIN	NOM	MAX
A2	1.00	1.10	1.20
A3	0.62	0.67	0.72
A4	0.25	0.30	0.35
b	0.30	————	0.40
b1	0.30	————	0.35
c	0.08	————	0.22
c1	0.08	0.13	0.20
D	2.80	2.90	3.00
E	3.60	3.80	4.00
E1	1.50	1.60	1.70
e	0.95 BSC		
e1	1.90 BSC		
L1	1.00	1.10	1.20
s	0.46	0.51	0.56
theta1	5°	6°	15°
theta2	5°	8°	15°

NOTE :

1. ALL DIMENSIONS ARE IN MILLIMETERS.
2. DIMENSION D DOES NOT INCLUDE MOLD FLASH, PROTRUSION OR GATE BURRS. MOLD FLASH PROTRUSIONS OR GATE BURRS SHALL NOT EXCEED 0.15 mm PER END. DIMENSION E1 DOES NOT INCLUDE INTERLEAD FLASH OR PROTRUSION. INTERLEAD FLASH OR PROTRUSION SHALL NOT EXCEED 0.15 mm PER SIDE.
3. THE PACKAGE TOP MAY BE SMALLER THAN THE PACKAGE BOTTOM. DIMENSIONS D AND E1 ARE DETERMINED AT THE OUTERMOST EXTREMES OF THE PLASTIC BODY EXCLUSIVE OF MOLD FLASH, TIE BAR BURRS, GATE BURRS AND INTERLEAD FLASH, BUT INCLUDING ANY MISMATCH BETWEEN THE TOP AND BOTTOM OF THE PLASTIC BODY.
4. DIMENSION "b & b2" DOES NOT INCLUDE DAMBAR PROTRUSION. ALLOWABLE DAMBAR PROTRUSION SHALL BE 0.08 mm TOTAL IN EXCESS OF THE "b & b2" DIMENSION AT MAXIMUM MATERIAL CONDITION. THE DAMBAR CANNOT BE LOCATED ON THE LOWER RADIUS OF THE FOOT. MINIMUM SPACE BETWEEN PROTRUSION AND AN ADJACENT LEAD SHALL NOT BE LESS THAN 0.07 mm.
5. LEAD FRAME MATERIAL : EETEC-64T

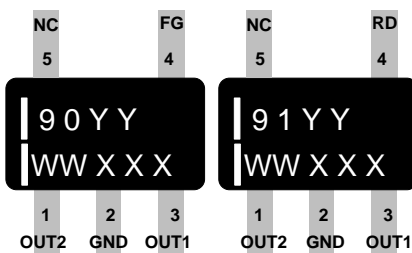

Top marking US91A, US90A

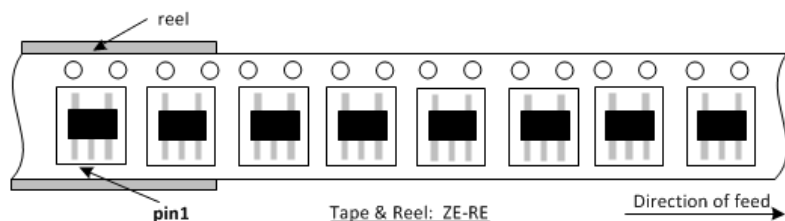

12. Standard Information

Our products are classified and qualified regarding soldering technology, solderability and moisture sensitivity level according to standards in place in Semiconductor industry.

For further details about test method references and for compliance verification of selected soldering method for product integration, Melexis recommends reviewing on our web site the General Guidelines [soldering recommendation](#). For all soldering technologies deviating from the one mentioned in above document (regarding peak temperature, temperature gradient, temperature profile etc), additional classification and qualification tests have to be agreed upon with Melexis.

For package technology embedding trim and form post-delivery capability, Melexis recommends to consult the dedicated trim&form recommendation application note: [lead trimming and forming recommendations](#)

Melexis is contributing to global environmental conservation by promoting **lead free** solutions. For more information on qualifications of **RoHS** compliant products (RoHS = European directive on the Restriction Of the use of certain Hazardous Substances) please visit the quality page on our website: <http://www.melexis.com/en/quality-environment>

13. ESD Precautions

Electronic semiconductor products are sensitive to Electro Static Discharge (ESD).

Always observe Electro Static Discharge control procedures whenever handling semiconductor products.

14. Disclaimer

The information furnished by Melexis herein is believed to be correct and accurate. Melexis disclaims (i) any and all liability in connection with or arising out of the furnishing, performance or use of the technical data or use of the product as described herein, (ii) any and all liability, including without limitation, special, consequential or incidental damages, and (iii) any and all warranties, express, statutory, implied, or by description, including warranties of fitness for particular purpose, non-infringement and merchantability. No obligation or liability shall arise or flow out of Melexis' rendering of technical or other services.

The information contained herein is provided "as is" and Melexis reserves the right to change specifications and/or any other information contained herein at any time and without notice. Therefore, before placing orders and/or prior to designing this product into a system, users or any third party should obtain the latest version of the relevant information to verify that the information being relied upon is current. This document supersedes and replaces all prior information regarding the product(s) as described herein and/or previous versions of this document.

Users or any third party must further determine the suitability of the Melexis' product(s) described herein for its application, including the level of reliability required and determine whether it is fit for a particular purpose.

The information contained herein is proprietary and/or confidential information of Melexis. The information contained herein or any use thereof does not grant, explicitly or implicitly, to any party any patent rights, licenses, or any other intellectual property rights, whether with regard to such information itself or anything described by such information. This document as well as the product(s) described herein may be subject to export control regulations. Please be aware that export might require a prior authorization from competent authorities.

The product(s) as described herein is/are intended for use in normal commercial applications. Unless otherwise agreed upon in writing, the product(s) described herein are not designed, authorized or warranted to be suitable in applications requiring extended temperature range, unusual environmental requirements. High reliability applications, such as medical life-support or life-sustaining equipment are specifically not recommended by Melexis.

The product(s) may not be used for the following applications subject to export control regulations: the development, production, processing, operation, maintenance, storage, recognition or proliferation of 1) chemical, biological or nuclear weapons, or for the development, production, maintenance or storage of missiles for such weapons; 2) civil firearms, including spare parts or ammunition for such arms; 3) defense related products, or other material for military use or for law enforcement; 4) any applications that, alone or in combination with other goods, substances or organisms could cause serious harm to persons or goods and that can be used as a means of violence in an armed conflict or any similar violent situation.

Products sold by Melexis are subject to the terms and conditions as specified in the Terms of Sale, which can be found at <https://www.melexis.com/en/legal/terms-and-conditions>.

Melexis NV © - No part of this document may be reproduced without the prior written consent of Melexis. (2016)

ISO/TS 16949 and ISO14001 Certified

15. Revision History Table

006	<p>Added US91AEVK-AAA000-RX options</p> <p>Added Ton/Toff specification.</p> <p>Added SOT straight leads package: 11.5ZE Package (SOT25 with straight leads)</p> <p>Added marking info VA, VK</p> <p>Added ESD hbm rating</p> <p>Corrected characterization graphs for RDson</p>
-----	--

Table 8

16. Contact

For the latest version of this document, go to our website at www.melexis.com.

For additional information, please contact our Direct Sales team and get help for your specific needs:

Europe, Africa	Telephone: +32 13 67 04 95
	Email : sales_europe@melexis.com
Americas	Telephone: +1 603 223 2362
	Email : sales_usa@melexis.com
Asia	Email : sales_asia@melexis.com

X-ON Electronics

Largest Supplier of Electrical and Electronic Components

Click to view similar products for [Motor/Motion/Ignition Controllers & Drivers](#) category:

Click to view products by [Melexis](#) manufacturer:

Other Similar products are found below :

[FSB50550TB2](#) [FSBF15CH60BTH](#) [MSVCPM2-63-12](#) [MSVGW45-14-2](#) [MSVGW54-14-3](#) [MSVGW54-14-5](#) [NTE7043](#) [LA6565VR-TLM-E](#)
[LB11650-E](#) [LB1837M-TLM-E](#) [LB1845DAZ-XE](#) [LC898300XA-MH](#) [SS30-TE-L-E](#) [26700](#) [LV8281VR-TLM-H](#) [BA5839FP-E2](#) [IRAM236-1067A](#) [LA6584JA-AH](#) [LB11847L-E](#) [NCV70501DW002R2G](#) [AH293-PL-B](#) [TND315S-TL-2H](#) [FNA23060](#) [FSB50250AB](#) [FNA41060](#)
[MSVB54](#) [MSVBTC50E](#) [MSVCPM3-54-12](#) [MSVCPM3-63-12](#) [MSVCPM4-63-12](#) [MSVTA120](#) [FSB50550AB](#) [NCV70501DW002G](#)
[LC898301XA-MH](#) [LV8413GP-TE-L-E](#) [MSVGW45-14-3](#) [MSVGW45-14-4](#) [MSVGW45-14-5](#) [MSVGW54-14-4](#) [STK984-091A-E](#)
[SLA7026M](#) [MP6519GQ-Z](#) [LB11651-E](#) [IRSM515-025DA4](#) [LV8127T-TLM-H](#) [MC33812EKR2](#) [NCP81382MNTXG](#) [TDA21801](#)
[LB11851FA-BH](#) [NCV70627DQ001R2G](#)