

MERIT SENSOR 1510 I²C COMMUNICATION

I²C Write, Command Byte, and 2 Data Bytes

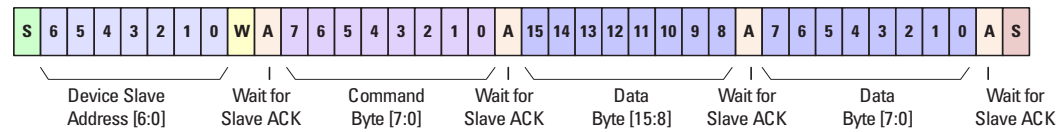

I²C Write, Command Byte, No Data Bytes



NOTE: Standard address = 0x28 (other addresses available upon request)

The correct command to write to the unit for setting up the data read is "0x2E 0x21 0x00". This write command interrupts the normal operation of the ASIC and should only be used once to "activate" the register that holds the pressure data. Once the register is activated, any subsequent read of the device will return the data from that register.

I²C Read, 2 (+n) Data Bytes

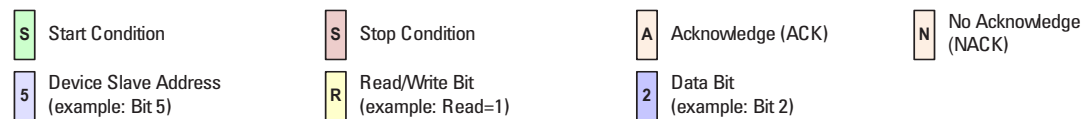
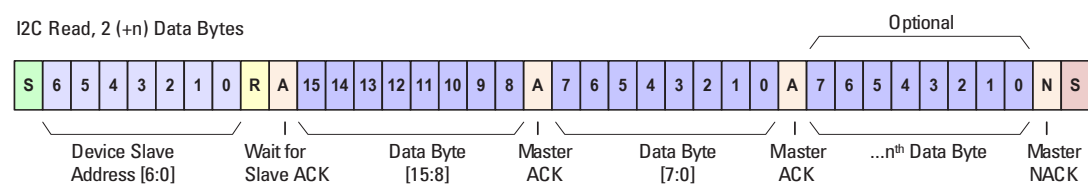

A read command will return the data from the output register. It will not interrupt the normal processing of the ASIC. Three bytes of data should be read... the first byte is the original command (0x2E), the next two bytes are the pressure output in counts.

TRANSFER FUNCTION EXAMPLE

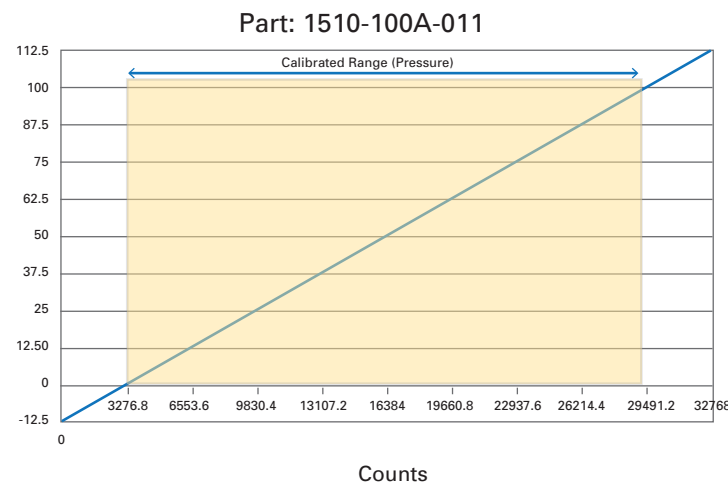

The HTS 1510 Series is a surface-mountable package with both digital and analog outputs available. Its backside-pressure measurement provides great compatibility with wet, corrosive media. It is ideal for integration on a control board.

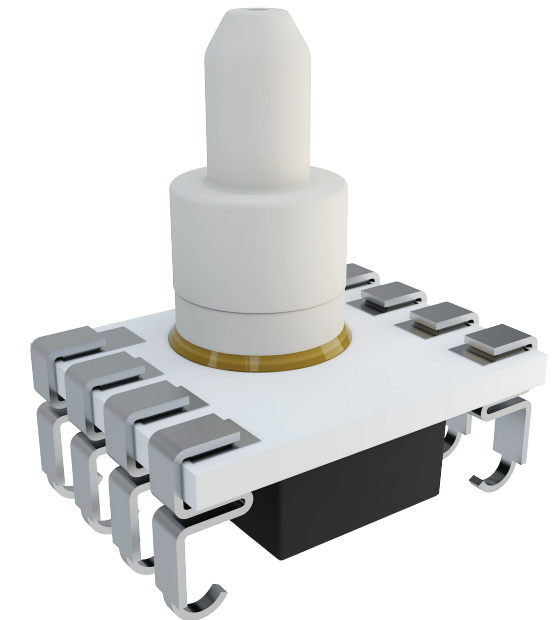

FEATURES

Pressure Range	1 to 100 psi / 70 to 7000 mbar / 7 to 700 kPa
Temp.	-40 to 125 °C
Output Type	Digital I ² C and Analog 0.5V – 4.5V
Type	Absolute or Gage
Packaging	Tape and Reel

APPLICATIONS

Industrial: To monitor HVAC systems, water levels, water pressure, and processes. It is also used for air-conditioning and other refrigerant systems, portable-measurement and analysis instrumentation, and industrial automation.

Automotive: To monitor the pressure of transmission fluid, fuel systems, oil systems, EGR systems, exhaust gas, etc.

Medical: Used in equipment for diagnosis and analysis.

HTS Series Part Number Configurator

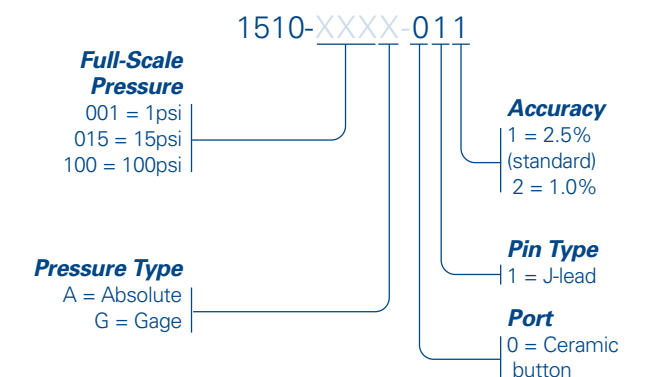

SPECIFICATIONS

Parameter	Minimum	Typical	Maximum	Units	Notes
Electrical					
Supply Voltage (Vs)	4.5	5	5.5	Vs	
Supply Current		6.5		mA	@5V input voltage.
Operating Temperature	-40		125	°C	
Storage Temperature	-55			°C	
Weight		1.48		Grams	
Performance					
Effective ADC Resolution	13.5			Bits	
Accuracy					Applicable if Vs = nominal 5V. Accuracy includes all error for hysteresis and linearity over the entire operating temperature range. It does not include lifetime drift. -40°C to 125°C.
Standard	-2.5	0	2.5	%FS	
High Performance	-1.0	0	1.0	%FS	
Analog Output Range (Vout)	10		90	%Vs	0 to 100 optional
Analog Output Clipping Limit (Vout)	0		100	%Vs	Other limits optional
Lifetime Drift	-0.5		0.5	%FS	
Startup Time			10	ms	
Digital Update Time		5		ms	
Proof Pressure	2X				Full scale pressure.
Burst Pressure	5X				

Transfer Function Formula - Digital

$$P_{psi} = (P_{max} - P_{min}) \cdot \left(\frac{P_{counts} - 0.1 \cdot Max}{0.8 \cdot Max} \right) + P_{min}$$

Where

P_{psi} = Measured Pressure in PSI
 P_{counts} = Pressure Counts from Merit Sensor Part
 P_{Min} = Minimum Pressure
 P_{Max} = Maximum Pressure
 Max = 32768 = 15 Bits

Transfer Function Formula - Analog

$$P_{psi} = (P_{max} - P_{min}) \cdot \left(\frac{V_{out} - V_{min}}{V_{max} - V_{min}} \right) + P_{min}$$

Where

P_{psi} = Measured Pressure in PSI
 P_{Max} = Maximum Pressure
 P_{Min} = Minimum Pressure
 V_{min} = Minimum Volatage (Usually 0.5V)
 V_{max} = Maximum Volatage (Usually 4.5V)
 V_{out} = Output voltage

ELECTRICAL

Note: The HTS product is represented by the blue dashed line. The customer needs to include the other capacitors in their circuit.

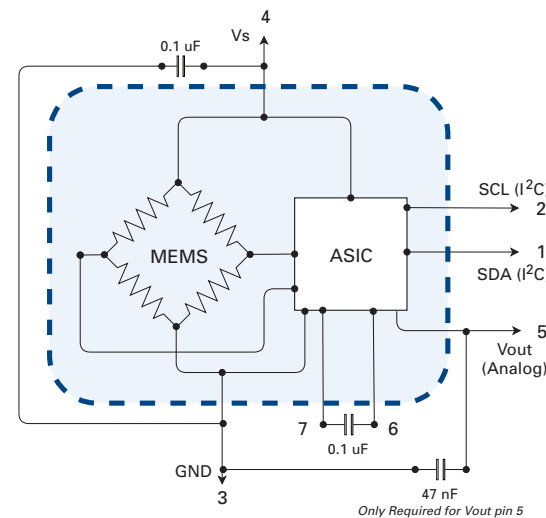

DIMENSIONS FOR STANDARD OPTIONS (in millimeters)

Dimensions for reference only. Engineering drawings (with tolerance) available upon order.

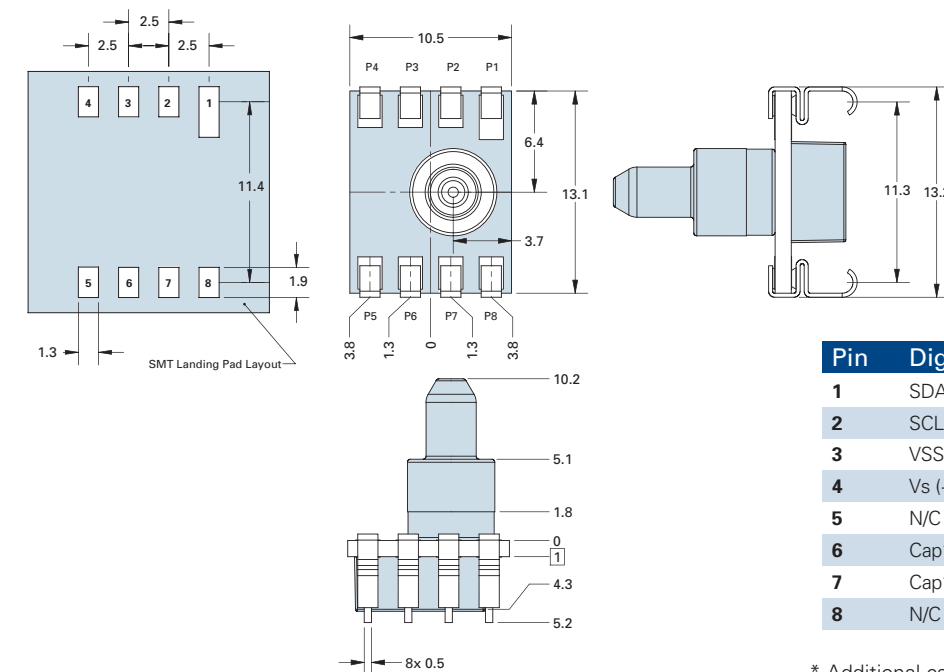

Pin	Digital	Analog
1	SDA	N/C
2	SCL	N/C
3	VSSE (Ground)	GND
4	Vs (+5V)	Vs (+5V)
5	N/C	Vout
6	Cap*	Cap*
7	Cap*	Cap*
8	N/C	N/C

* Additional capacitor required between pins 6 & 7 (refer to electrical schematic).

I²C PARAMETERS (FOR REFERENCE ONLY)

Nr.	Parameter	Symbol	Condition	Min	Typ	Max	Units
1	SCL clock frequency	f_{SCL}				400	kHz
2	Bus free time between start and stop condition	t_{I2C_BF}		1.3			μ s
3	Hold time start condition	$t_{I2C_HD_STA}$		0.6			μ s
4	Setup time repeated start condition	$t_{I2C_SU_STA}$		0.6			μ s
5	Low period SCL/SDA	t_{I2C_L}		1.3			μ s
6	High period SCL/SDA	t_{I2C_H}		0.6			μ s
7	Data hold time	$t_{I2C_HD_DAT}$		0.1			μ s
8	Data setup time	$t_{I2C_SU_DAT}$		0.1			μ s
9	Rise time SCL/SDA	t_{I2C_R}				0.3	μ s
10	Fall time SCL/SDA	t_{I2C_F}				0.3	μ s
11	Setup time stop condition	$t_{I2C_SU_STO}$		0.6		0.3	μ s
12	Fall time SCL/SDA	t_{I2C_NI}	Spike suppression			50	μ s

I²C TIMING DIAGRAM (FOR REFERENCE ONLY)

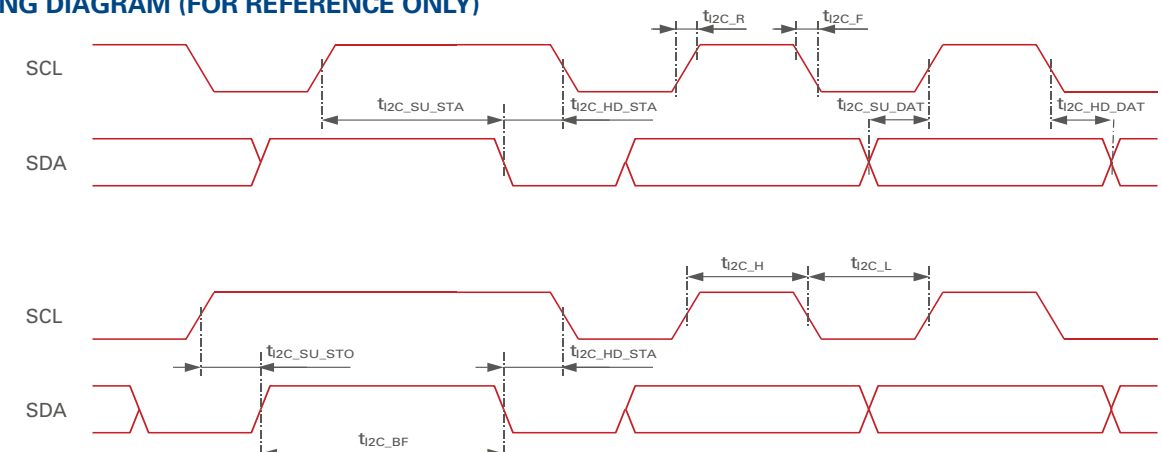

SPECIFICATIONS

Parameter	Minimum	Typical	Maximum	Units	Notes
Electrical					
Supply Voltage (Vs)	4.5	5	5.5	Vs	
Supply Current		6.5		mA	@5V input voltage.
Operating Temperature	-40		125	°C	
Storage Temperature	-55			°C	
Weight		1.48		Grams	
Performance					
Effective ADC Resolution	13.5			Bits	
Accuracy					Applicable if Vs = nominal 5V. Accuracy includes all error for hysteresis and linearity over the entire operating temperature range. It does not include lifetime drift. -40°C to 125°C.
Standard	-2.5	0	2.5	%FS	
High Performance	-1.0	0	1.0	%FS	
Analog Output Range (Vout)	10		90	%Vs	0 to 100 optional
Analog Output Clipping Limit (Vout)	0		100	%Vs	Other limits optional
Lifetime Drift	-0.5		0.5	%FS	
Startup Time			10	ms	
Digital Update Time		5		ms	
Proof Pressure	2X				Full scale pressure.
Burst Pressure	5X				

Transfer Function Formula - Digital

$$P_{psi} = (P_{max} - P_{min}) \cdot \left(\frac{P_{counts} - 0.1 \cdot Max}{0.8 \cdot Max} \right) + P_{min}$$

Where

P_{psi} = Measured Pressure in PSI
 P_{counts} = Pressure Counts from Merit Sensor Part
 P_{Min} = Minimum Pressure
 P_{Max} = Maximum Pressure
 Max = 32768 = 15 Bits

Transfer Function Formula - Analog

$$P_{psi} = (P_{max} - P_{min}) \cdot \left(\frac{V_{out} - V_{min}}{V_{max} - V_{min}} \right) + P_{min}$$

Where

P_{psi} = Measured Pressure in PSI
 P_{Max} = Maximum Pressure
 P_{Min} = Minimum Pressure
 V_{min} = Minimum Volatage (Usually 0.5V)
 V_{max} = Maximum Volatage (Usually 4.5V)
 V_{out} = Output voltage

ELECTRICAL

Note: The HTS product is represented by the blue dashed line. The customer needs to include the other capacitors in their circuit.

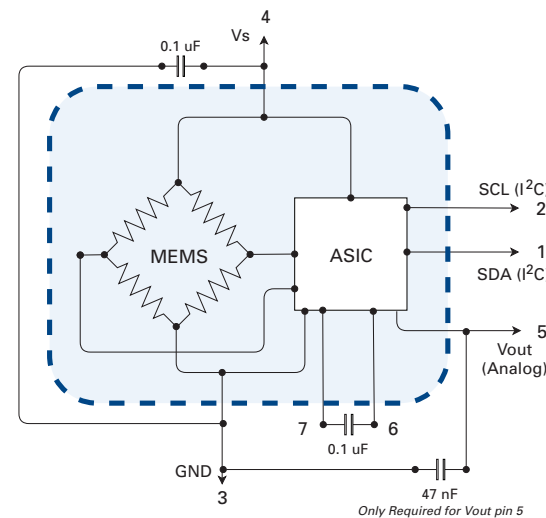

DIMENSIONS FOR STANDARD OPTIONS (in millimeters)

Dimensions for reference only. Engineering drawings (with tolerance) available upon order.

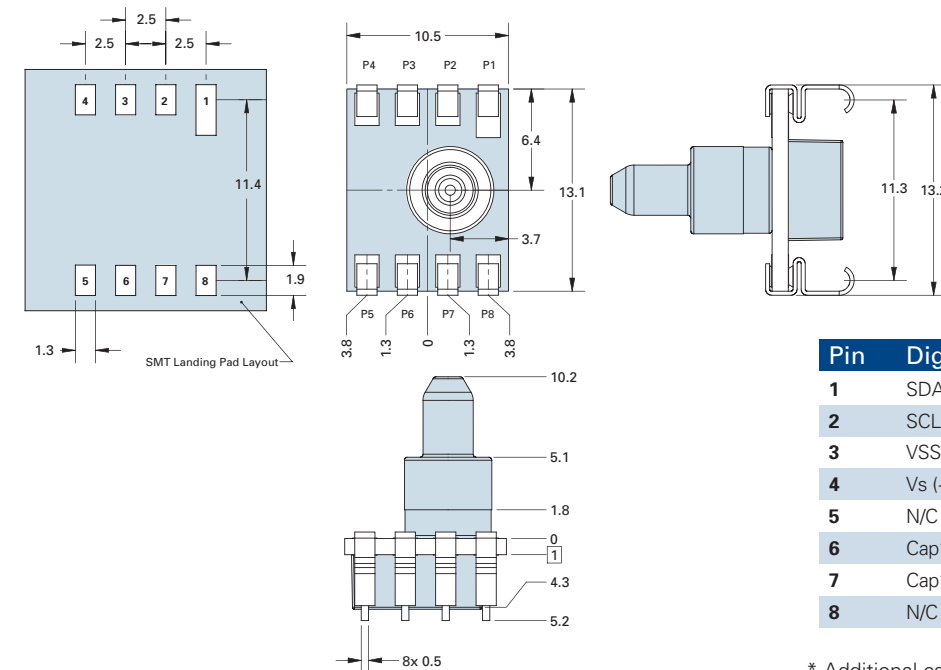

Pin	Digital	Analog
1	SDA	N/C
2	SCL	N/C
3	VSSE (Ground)	GND
4	Vs (+5V)	Vs (+5V)
5	N/C	Vout
6	Cap*	Cap*
7	Cap*	Cap*
8	N/C	N/C

* Additional capacitor required between pins 6 & 7 (refer to electrical schematic).

I²C PARAMETERS (FOR REFERENCE ONLY)

Nr.	Parameter	Symbol	Condition	Min	Typ	Max	Units
1	SCL clock frequency	f_{SCL}				400	kHz
2	Bus free time between start and stop condition	t_{I2C_BF}		1.3			μ s
3	Hold time start condition	$t_{I2C_HD_STA}$		0.6			μ s
4	Setup time repeated start condition	$t_{I2C_SU_STA}$		0.6			μ s
5	Low period SCL/SDA	t_{I2C_L}		1.3			μ s
6	High period SCL/SDA	t_{I2C_H}		0.6			μ s
7	Data hold time	$t_{I2C_HD_DAT}$		0.1			μ s
8	Data setup time	$t_{I2C_SU_DAT}$		0.1			μ s
9	Rise time SCL/SDA	t_{I2C_R}				0.3	μ s
10	Fall time SCL/SDA	t_{I2C_F}				0.3	μ s
11	Setup time stop condition	$t_{I2C_SU_STO}$		0.6		0.3	μ s
12	Fall time SCL/SDA	t_{I2C_NI}	Spike suppression			50	μ s

I²C TIMING DIAGRAM (FOR REFERENCE ONLY)

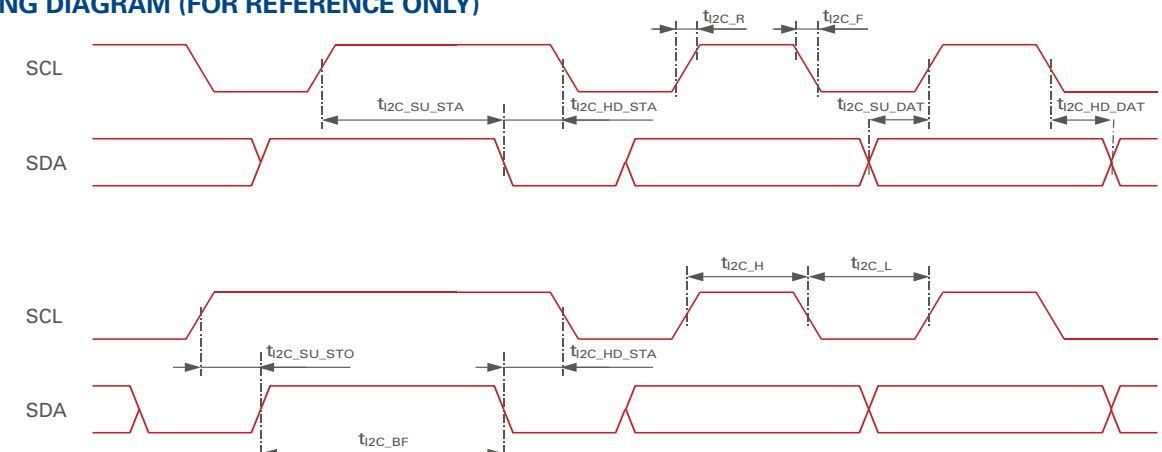

MERIT SENSOR 1510 I²C COMMUNICATION

I²C Write, Command Byte, and 2 Data Bytes

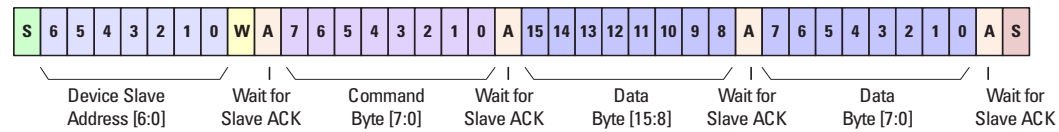

I²C Write, Command Byte, No Data Bytes



NOTE: Standard address = 0x28 (other addresses available upon request)

The correct command to write to the unit for setting up the data read is "0x2E 0x21 0x00". This write command interrupts the normal operation of the ASIC and should only be used once to "activate" the register that holds the pressure data. Once the register is activated, any subsequent read of the device will return the data from that register.

I²C Read, 2 (+n) Data Bytes

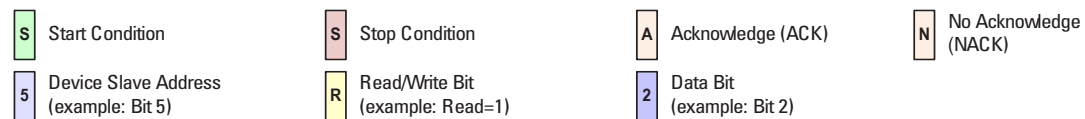
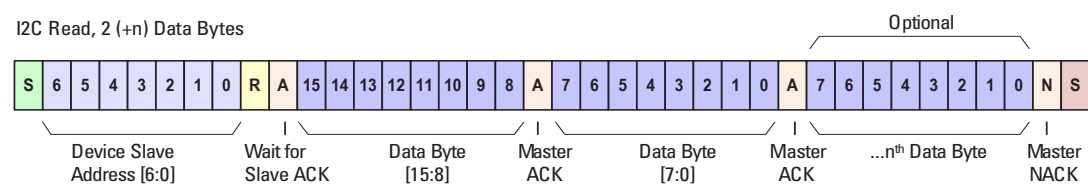

A read command will return the data from the output register. It will not interrupt the normal processing of the ASIC. Three bytes of data should be read... the first byte is the original command (0x2E), the next two bytes are the pressure output in counts.

TRANSFER FUNCTION EXAMPLE

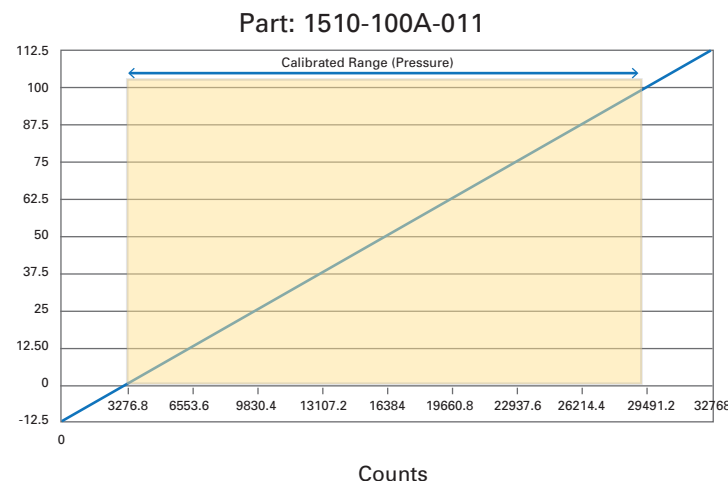

The HTS 1510 Series is a surface-mountable package with both digital and analog outputs available. Its backside-pressure measurement provides great compatibility with wet, corrosive media. It is ideal for integration on a control board.

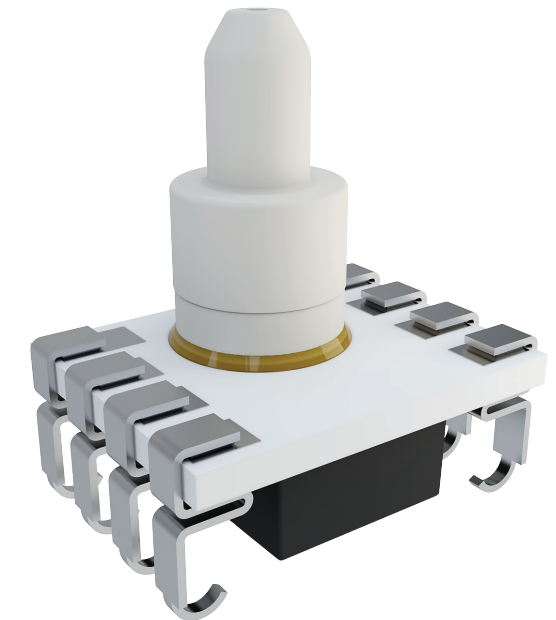

FEATURES

Pressure Range	1 to 100 psi / 70 to 7000 mbar / 7 to 700 kPa
Temp.	-40 to 125 °C
Output	Digital I ² C and Analog 0.5V – 4.5V
Type	Absolute or Gage
Packaging	Tape and Reel

APPLICATIONS

Industrial: To monitor HVAC systems, water levels, water pressure, and processes. It is also used for air-conditioning and other refrigerant systems, portable-measurement and analysis instrumentation, and industrial automation.

Automotive: To monitor the pressure of transmission fluid, fuel systems, oil systems, EGR systems, exhaust gas, etc.

Medical: Used in equipment for diagnosis and analysis.

HTS Series Part Number Configurator

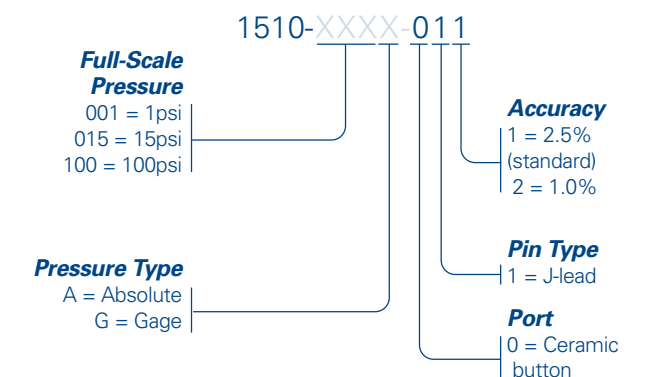

X-ON Electronics

Largest Supplier of Electrical and Electronic Components

Click to view similar products for [Board Mount Pressure Sensors](#) category:

Click to view products by [Merit Sensor](#) manufacturer:

Other Similar products are found below :

[6407-249V-17343P](#) [6407-250V-09273P](#) [6407-250V-09343P](#) [80527-25.0H2-05](#) [80541-B00000150-01](#) [80541-B00000200-05](#) [80554-00700100-05](#) [80568-00300050-01](#) [93.631.4253.0](#) [93.731.4353.0](#) [93.932.4553.0](#) [136PC15A1](#) [142PC95AW71](#) [142PC05DW70](#) [15PSI-G-4V](#) [1805-01A-L0N-B](#) [26PCBKT](#) [26PCCFA6D26](#) [26PCCFS2G](#) [26PCCVA6D](#) [93.632.7353.0](#) [93.731.3653.0](#) [93.931.4853.0](#) [93.932.4853.0](#) [SDP510-500PA](#) [185PC30DH](#) [20INCH-G-MV-MINI](#) [26PCAFJ3G](#) [26PCCEP5G24](#) [26PCCFJ3G](#) [26PCDFA3G](#) [26PCJEU5G19](#) [30INCH-D1-MV-MINI](#) [ASCX15AN-90](#) [ASCX15AN/SZ76114](#) [4426-015G](#) [4525-DS5A030DP](#) [DCAL401DN](#) [DCAL401GN](#) [4515-DS5A020DP](#) [XZ202798SSC](#) [XZ203676HSC](#) [6407-249V-09273P](#) [6407-249V-09343P](#) [6407-249V-17273P](#) [6407-250V-17273P](#) [6407-250V-17343P](#) [81717-00000050-05](#) [81794-B00001200-01](#) [82681-B00000100-01](#)