

SPECIFICATIONS

Customer : _____

 Customer P/N: _____ ACW- Series

Drawing No : _____

 Quantity : 0 Pcs. Date : 2017/09/06

 Meled P/N : _____ ACW- Series/参照

SPECIFICATION	
ACCEPTED BY:	
COMPONENT ENGINEER	
ELECTRICAL ENGINEER	
MECHANICAL ENGINEER	
APPROVED	
REJECTED	

For Customer approval Only

 Qualification Status: Full Restricted Rejected

Approved By	Verified By	Re-checked By	Checked By

Comments: _____

Version change history

Rev.	Effective Date	Changed Contents	Change Reasons	Approved By
01	/	New release	/	/

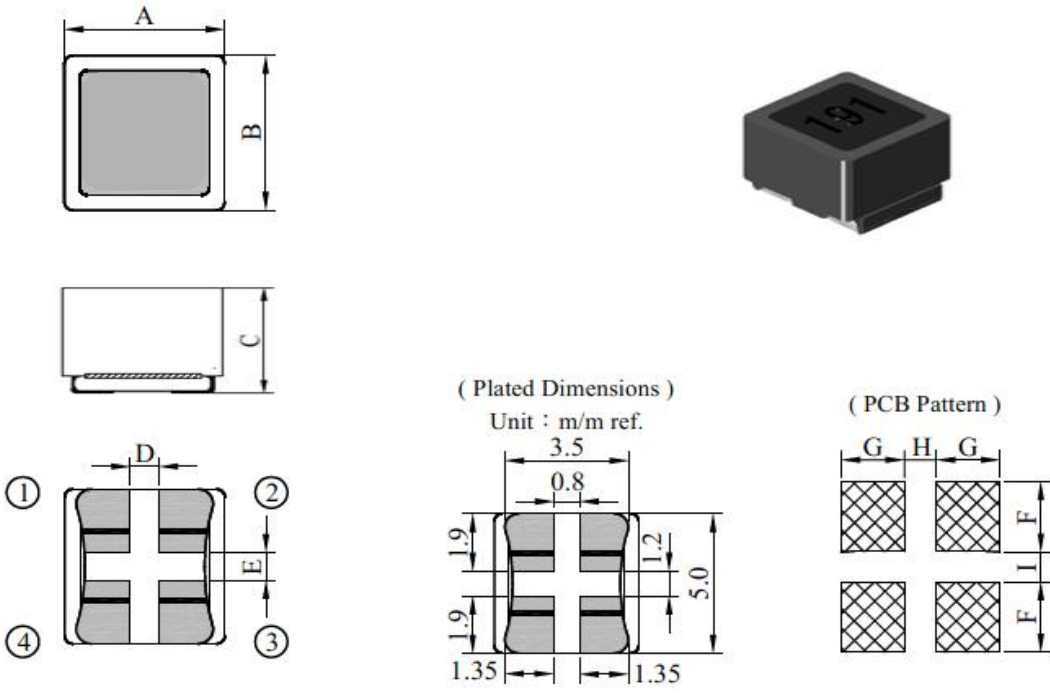
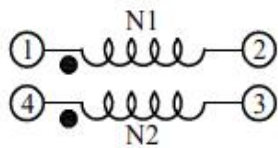
CUSTOMER	0	CUSTOMER P/N	-----	REV.	A	
PRODUCT TYPE		Meled P/N	ACW5020-SERIES	FILE NO.	SP-20103001	
1. DIMENSION (UNIT : mm) 				A	4.8 ±0.2	
				B	5.0 ±0.2	
				C	2.5 Max	
				D	0.8 Typ	
				E	1.0 Typ	
				F	2.3 Ref	
				G	1.6 Ref	
				H	0.8 Ref	
				I	1.0 Ref	
2. CIRCUIT DIAGRAM		3. NOTE :				
						
4. ELECTRICAL CHARACTERISTIC						
Meled P/N	Common mode Impedance (Ω)	Test Frequency	Rated Voltage (V) MAX	DCR (mΩ) MAX	Rated Current (A) Max.	IR (MΩ) MIN
ACW5020-101T60	100 (Typ)	100MHz/0.5V	50	13	6.0	10
ACW5020-251T50	250 (Typ)	100MHz/0.5V	50	20	5.0	10
ACW5020-421T40	420 (Typ)	100MHz/0.5V	50	27	4.0	10
ACW5020-501T40	500 (Typ)	100MHz/0.5V	50	27	4.0	10
ACW5020-102T20	1000 (Typ)	100MHz/0.5V	50	34	2.0	10
ACW5020-142T15	1400 (Typ)	100MHz/0.5V	50	56	1.5	10
ACW5020-152T15	1500 (Typ)	100MHz/0.5V	50	56	1.5	10

1.IDC: ΔT=40℃Typ.
2.I.R: 50V(DC)/0.5S

CUSTOMER	0	CUSTOMER P/N	-----	REV.	A
PRODUCT		Meled P/N	ACW5020-SERIES	FILE NO.	SP-20103001

5. CHARACTERISTICS(REFERENCE)

ACW5020-251T50

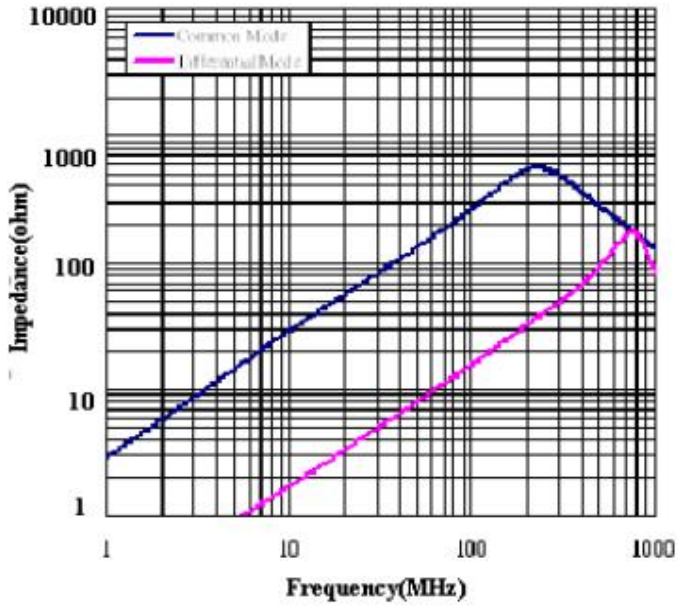

ACW5020-501T40

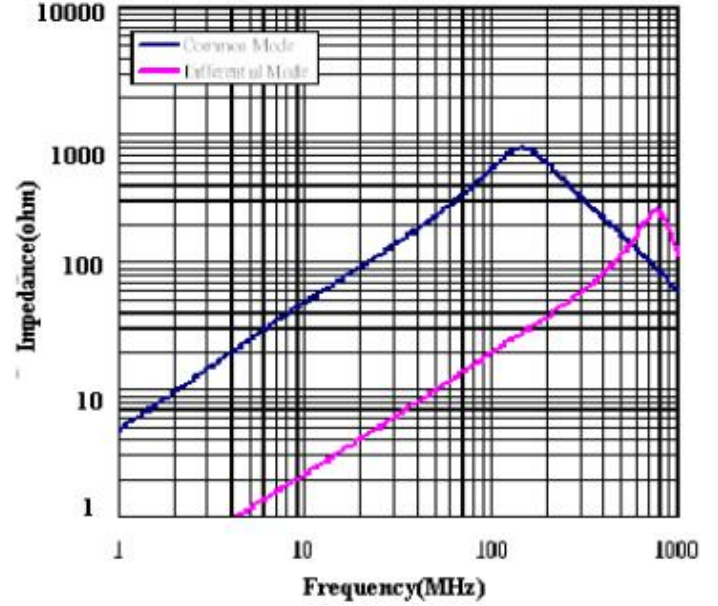

ACW5020-102T20

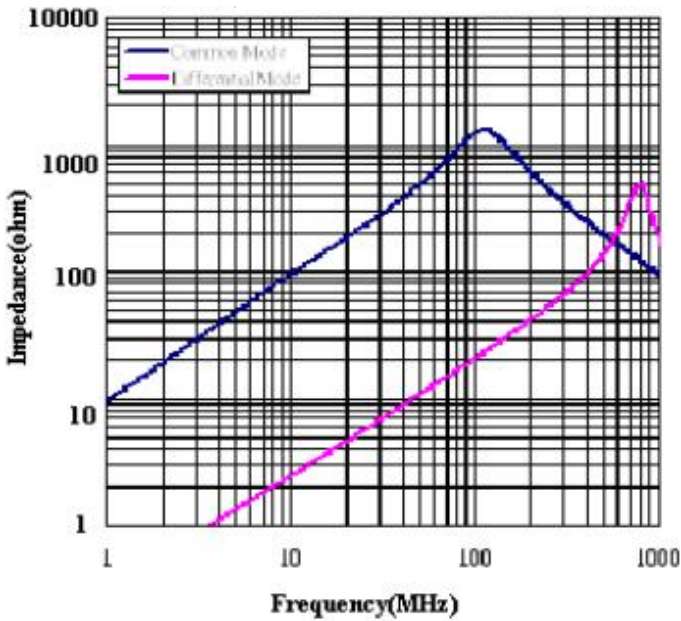

ACW5020-152T15

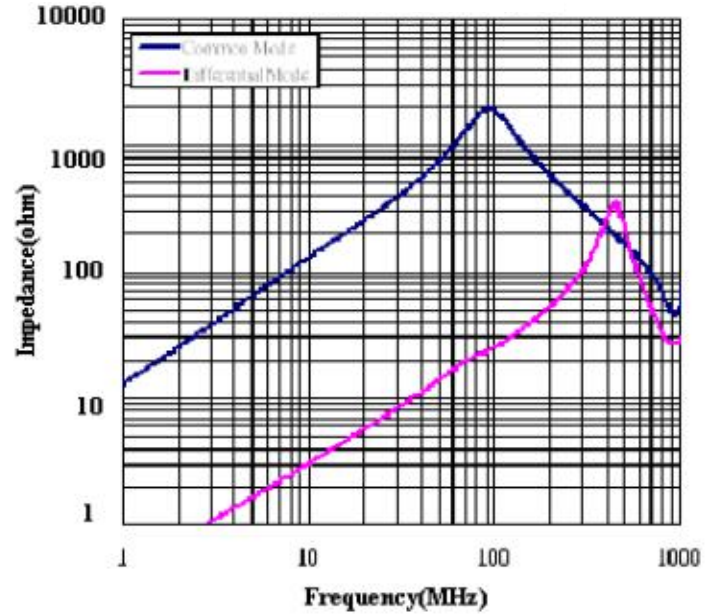

CUSTOMER	0	CUSTOMER P/N	-----	REV.	A
PRODUCT		Meled P/N	ACW5020-SERIES	FILE NO.	SP-20103001

5. CHARACTERISTICS(REFERENCE)

ACW5020-421T40

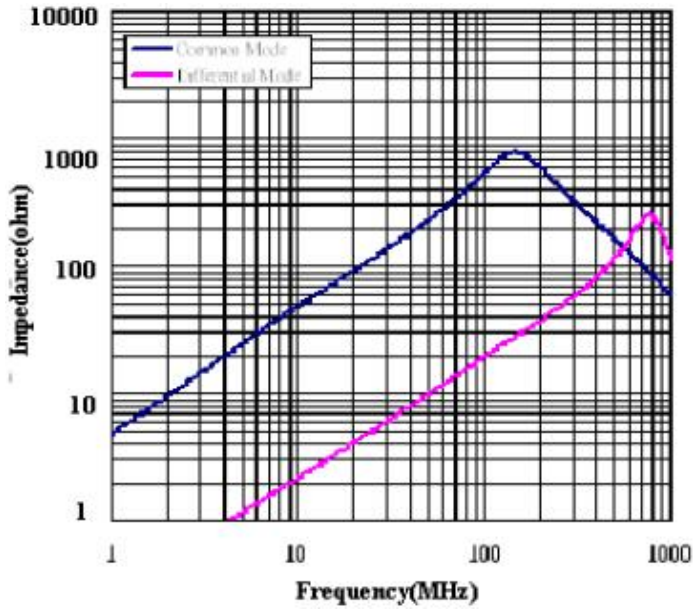

CUSTOMER	0	CUSTOMER P/N	-----	REV.	A
PRODUCT		Meled P/N	ACW5020-SERIES	FILE NO.	SP-20103001

6. MATERIAL LIST

NO.	ITEM	DESCRIPTION	SUPPLIER
1	CORE	FERRITE	FENGYIN OR EQ
2	WIRE	P180 Grd1	ELEKTRISOLA OR EQ
3	ADHESIVE	EPOXY RESIN	NAGASE OR EQ
4	SOLDER	Sn99.3:Cu0.7	SHENMAO OR EQ
8			

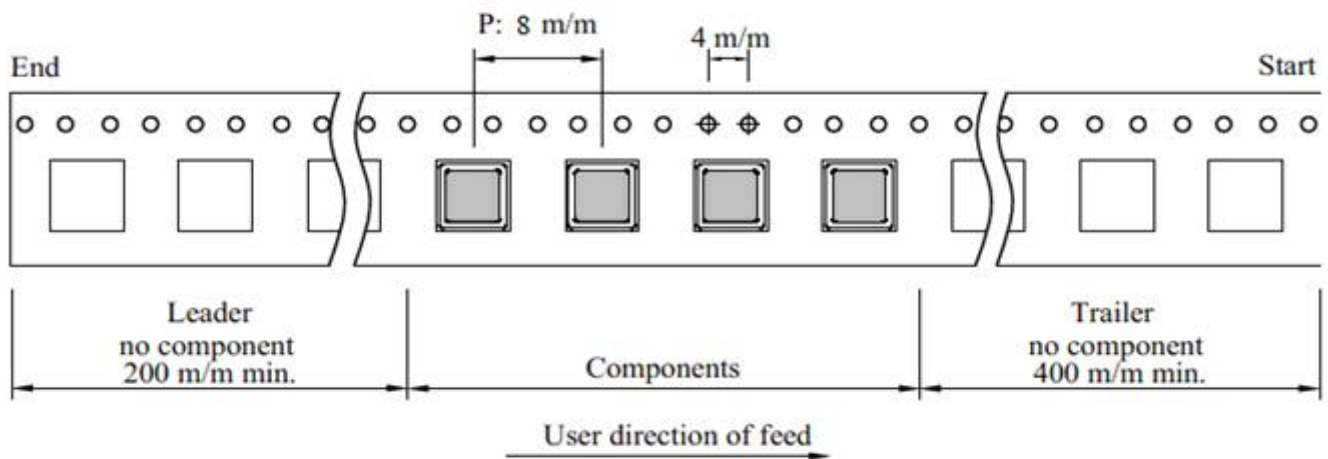
7. TAPING SPECIFICATIONS

Adhesive strength of cover tape is 20 to 120 gf
The conduction band direction

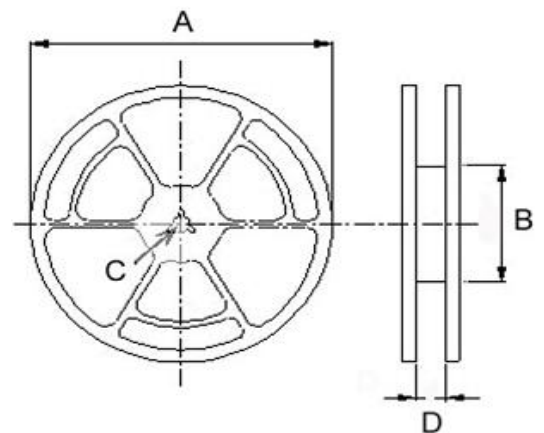
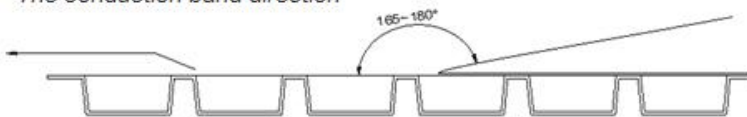

Reel Dimensions (Unit: mm)				Quantity
A	B	C	D	Pcs/Reel
330	100	13	12.5	2500

CUSTOMER	0	CUSTOMER P/N	-----	REV.	A
PRODUCT		Meled P/N	ACW5020-SERIES	FILE NO.	SP-20103001

8. RELIABILITY TESTING

Operating Temperature	- 40 to +125 °C (Contain Heating coil)
Appearance Inspection	No external defects by visual inspection
Terminal Strength	After soldering , between copper plaet and terminals of coils , push in two directions of X , Y with standing 10N(1.02kg) for10+/-2 sec. Terminal should not peel off. (Refer to figure at right)
Heat endurance of reflow soldering	Refer to figure
Insulating resistance	Over 100 MΩ at 100V D.C . between wire and core
Dielectric Strength	Apply at 0.5KV 3mA for 1 minute between wire and core
Temperature characteristics	Inductance coefficient (0~2,000) × 10 / °C (- 40~ + 125 °C)
Humidity characteristics	Inductance deviation within ± 10% , after 96 hours in 90~95% relative humidity at 40 ± 2 °C and 1 hours drying under normal condition

A test is made under the above mentioned condition , and it is kept for 2 hours in the normal

IR Reflow profile

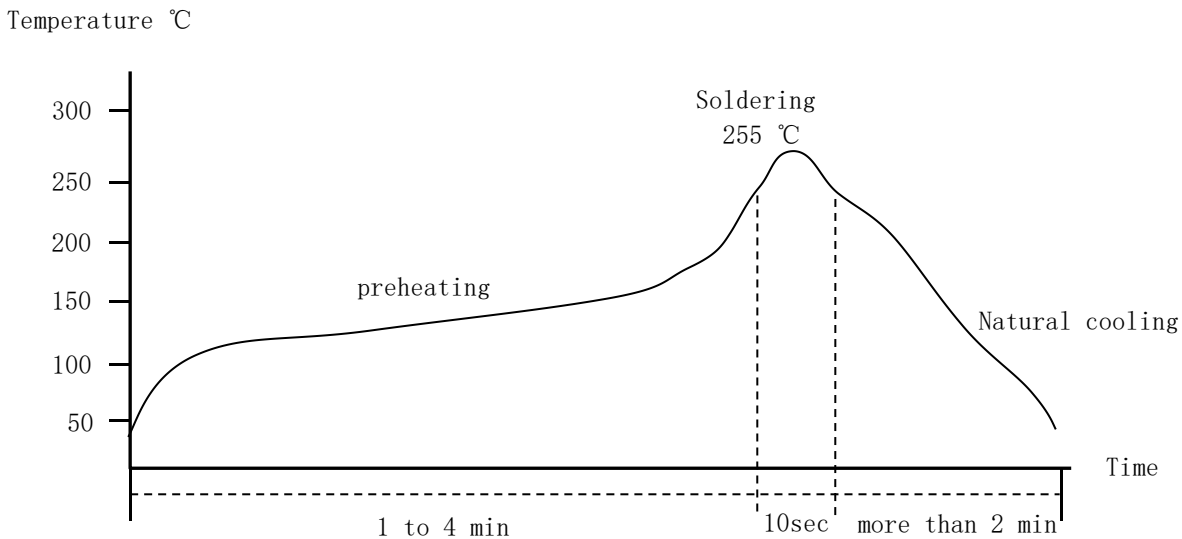

Temperature and humidity . After that , no mechanical and electrical defect should be found .

X-ON Electronics

Largest Supplier of Electrical and Electronic Components

Click to view similar products for [Common Mode Chokes / Filters](#) category:

Click to view products by [MetalLions](#) manufacturer:

Other Similar products are found below :

[PE-64683](#) [RD5122-6-9M6](#) [RD6137-6-7M5](#) [RD8147-16-3M0](#) [ST6118T-R](#) [FE3X025-10-7NL](#) [RD7147-25-0M7](#) [TCM0806G-350-2P-T](#)
[TCM0806G-650-2P-T](#) [IND-0110](#) [UAL21VR0802000](#) [UALSC023000000](#) [UALSC1020JH000](#) [UALSU10VD20010](#) [UALSU9VD070100](#) [36-00037](#) [UALW21HS072450](#) [UALSU9H0208000](#) [UAL24VK06450CH](#) [PLT10HH501100PNB](#) [PLT10HH401100PNB](#) [PLT10HH1026R0PNB](#)
[36-00029-01](#) [PE-67531](#) [TLH10UB](#) [113 0R5](#) [2752045447](#) [7351V](#) [CMF16-153131](#) [RD7147-6-6M0](#) [T8116NLT](#) [FE2X10-4-2NL](#) [36-00029-07](#)
[T8003NLT](#) [CTX01-13663](#) [CTX66-19521-R](#) [RC212-0.5-10M](#) [RC112-0.4-15M](#) [RC212-0.6-6M8](#) [RC212-0.4-15M](#) [RC112-0.3-30M](#)
[WTCF2012Z0M751PB](#) [PH9408.814NLT](#) [PAC6006.364NLT](#) [PAC6006.444NLT](#) [PAC6006.204NLT](#) [PH9407.204NLT](#) [PAC6006.264NLT](#)
[PH9408.105NLT](#) [PH9408.494NLT](#) [PAC6006.104NLT](#)