

MNR1050 Series

Wire Wound SMD Power Inductors

FEATURES

- Magnetic-resin shielded construction reduces buzz noise to ultra-low levels
- Metallization on ferrite core results in excellent shock resistance and damage-free durability
- Closed magnetic circuit design reduces leakage flux and Electro Magnetic Interference (EMI)
- 30% higher current rating than conventional inductors of equal size
- Takes up less PCB real estate and save more power
- Operate temperature range $-40^{\circ}\text{C} \sim +125^{\circ}\text{C}$ (Including self temp. rise)
- RoHS compliant



APPLICATIONS

- Smart phone, smart TV, set top box, notebook
- Car navigation systems, telecomm base stations
- VR, AR
- LED lighting

Explanation of Part Number

MNR 1050 T1R0 M T

1 2 3 4 5 6

- ◆ 1:Product Series:Wire Wound SMD Power Inductors
- ◆ 2:Dimensions:
- ◆ 3: Feature Type:T Type
- ◆ 4: Initial inductance value: 1R0 = 1.0uH
- ◆ 5: Tolerance of Inductance:M:±20%
- ◆ 6:Packing:Tape Carrier Package

Dimensions: [mm]

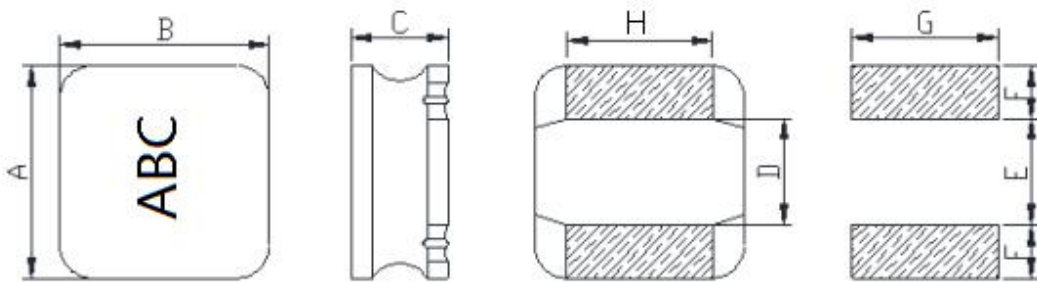

A	10.0±0.3
B	10.0±0.3
C	5.0Max.
D	6.4Ref
E	6.2Ref
F	2.0Ref
G	5.5Ref
H	4.2Ref

Electrical Characteristics List

规格型号 Part NO.	电感量 Tolerance(μ H)	测试频率 Test Freq. (kHz/v)	直流电阻 DC Max (Ω)	饱和电流 Isat (A)	温升电流 Irms (A)
MNR1050T1R0MT	1.0	100/0.25	0.018	14.2	6.40
MNR1050T1R5MT	1.5	100/0.25	0.020	12.8	6.00
MNR1050T2R2MT	2.2	100/0.25	0.025	12.1	5.50
MNR1050T3R3MT	3.3	100/0.25	0.027	11.2	5.00
MNR1050T4R7MT	4.7	100/0.25	0.030	10.3	4.60
MNR1050T6R8MT	6.8	100/0.25	0.037	9.00	4.20
MNR1050T100MT	10	100/0.25	0.048	7.20	3.70
MNR1050T150MT	15	100/0.25	0.059	6.00	3.20
MNR1050T220MT	22	100/0.25	0.085	4.30	2.70
MNR1050T330MT	33	100/0.25	0.104	4.00	2.30
MNR1050T470MT	47	100/0.25	0.163	3.30	2.00
MNR1050T680MT	68	100/0.25	0.235	3.00	1.80
MNR1050T101MT	100	100/0.25	0.338	2.50	1.40
MNR1050T151MT	150	100/0.25	0.438	2.00	1.20
MNR1050T221MT	220	100/0.25	0.675	1.80	1.00
MNR1050T271MT	270	100/0.25	0.858	1.50	0.90
MNR1050T331MT	330	100/0.25	1.10	1.40	0.85
MNR1050T471MT	470	100/0.25	1.43	1.20	0.73
MNR1050T561MT	560	100/0.25	1.75	1.10	0.68
MNR1050T681MT	680	100/0.25	1.98	1.00	0.65
MNR1050T821MT	820	100/0.25	2.73	0.90	0.55
MNR1050T102MT	1000	100/0.25	3.42	0.80	0.50

※Tolerance: N: \pm 30%、M: \pm 20%、K: \pm 10%.

※Operating temperature rang: -40 °C to +125°C (Including Self-heating)

※Storage temperature rang: -40 °C to +125°C

The rated DC current is that which cause at 30% inductance reduction from the initial value or inductor surface temperature to rise by 40°C, whichever is smaller (Reference ambient temperature 25°C)。

Reliability and Test Condition

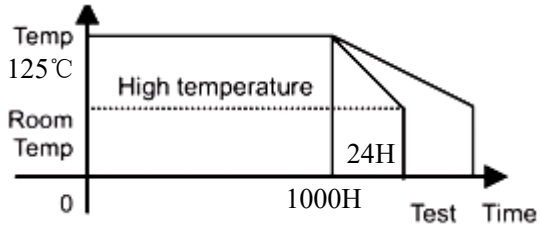
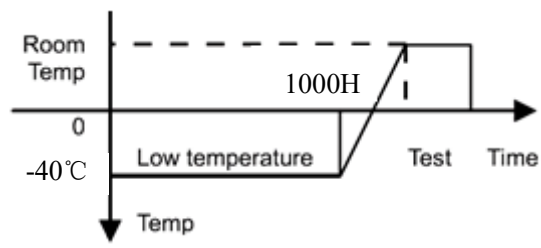
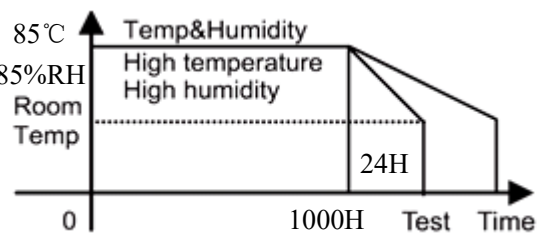
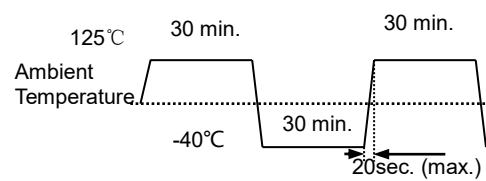
Item	Required Characteristics	Test Method/Condition
High temperature storage test		<p>Temperature: $125\pm 2^{\circ}\text{C}$ Time : 1000 hours Measurement at 24 ± 4 hours after test conclusion.</p> 
Low temperature storage test	<ol style="list-style-type: none"> No case deformation or change in appearance. $\Delta L/L \leq 10\%$ 	<p>Temperature : $-40\pm 2^{\circ}\text{C}$ Time : 1000 hours Measurement at 24 ± 4 hours after test conclusion.</p> 
Humidity test		<p>Temperature: $25-85^{\circ}\text{C}$, Humidity : 85% RH Time : 1000 hours. Measurement at 24 ± 4 hours after test conclusion.</p> 
Thermal shock test		<p>First -40°C for 30min. time, last 125°C 30min. time as 1 cycle. Go through 1000 cycles.</p> 

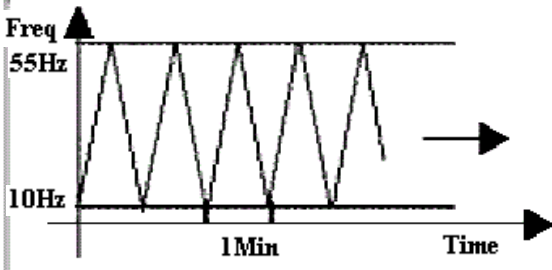
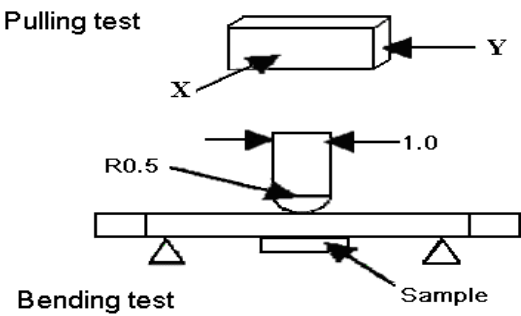
Item	Required Characteristics	Test Method/Condition
Solderability test	Terminal area must have 90% min. solder coverage.	Dip pads in flux then dip in solder pot at $245 \pm 5^{\circ}\text{C}$ for 5 ± 0.1 second. Solder: Sn96.5%、Ag3%、Cu0.5% Flux: rosin flux.
Heat endurance of reflow soldering		Refer to the next page reflow curve , Go through 3 times. The peak temperature: $260 + 5 / - 0^{\circ}\text{C}$
Vibration test	1. No case deformation or change in appearance. 2. $\Delta L/L \leq 10\%$	Apply frequency 10~55Hz. 1.5mm amplitude in each of perpendicular direction for 2 hours in each 3 mutually perpendicular directions.(total 6 hours) 
Drop test		Drop 10 times on a concrete floor from a height of 1m.
Terminal strength push test	Pulling test: Solder the products on testing PCB using eutectic solder. Then apply a force in the direction of the arrow. 17.64N force. Keep time $\geq 10\text{s}$ Bending test: Soldering the products on PCB, after the pulling test and bending test, terminal should not pull off.	Pulling test: The application of force X、 Y direction Bend the testing PCB at middle point, the deflection shall be 2mm. Pressurizing Speed: 0.5mm/sec, Keep time: $60 \pm 1\text{s}$, 
Loading at High Temperature	1. No case deformation or change in appearance. 2. $ \Delta L/L \leq 10\%$	1. Temperature: $85 \pm 2^{\circ}\text{C}$ 2. Time : 1000 hours 3. Apply rated current 4. Measurement at 24 ± 4 hours after test conclusion

Packaging

Tape packing diagram

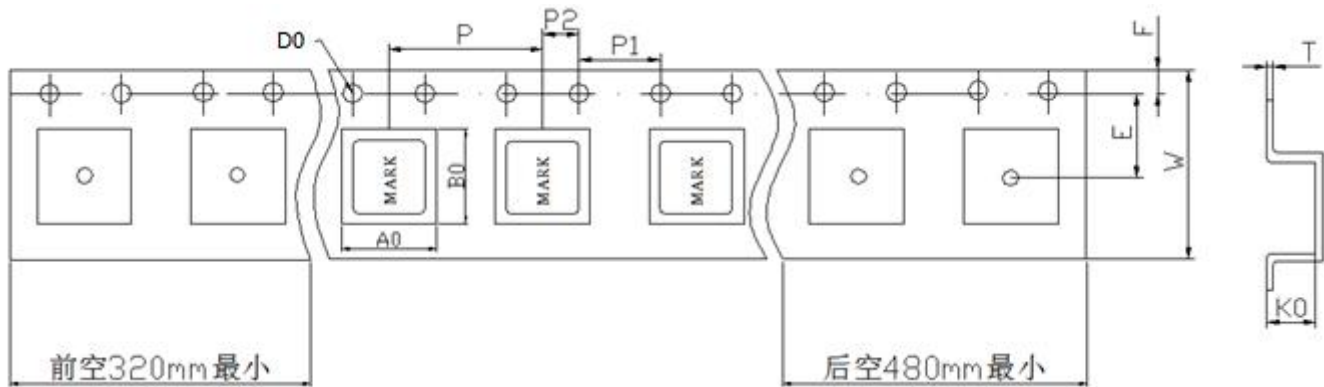

ITEM	W	A0	B0	K0	P	E	F	D0	P0	P2	T
DIM	24.00	10.4	10.4	5.2	16.00	7.5	1.75	1.50	4.00	2.00	0.40
TOLE	±0.3	±0.1	±0.1	±0.1	±0.1	±0.1	±0.1	+0.1	±0.1	±0.1	±0.05

Tape packing diagram

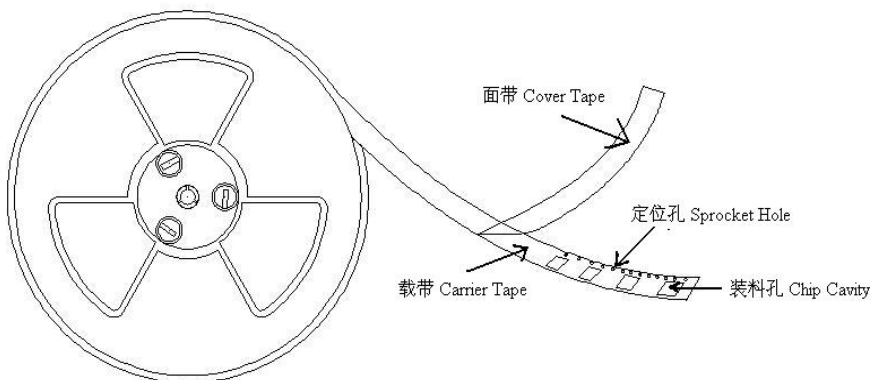

剥离强度要求 Peeling required

①F 力大小: 20~100g;

②面带剥离角度: 165°~180°。

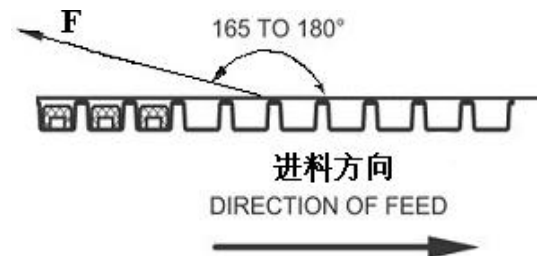

Packing quantity

Item	Quantity (PCS)	Dimension Size (mm)
Reel	800	13"
Inbox	1600	340mm*340mm*65mm
Outbox	3200	360mm*360mm*160mm

Re-flowing Profile:

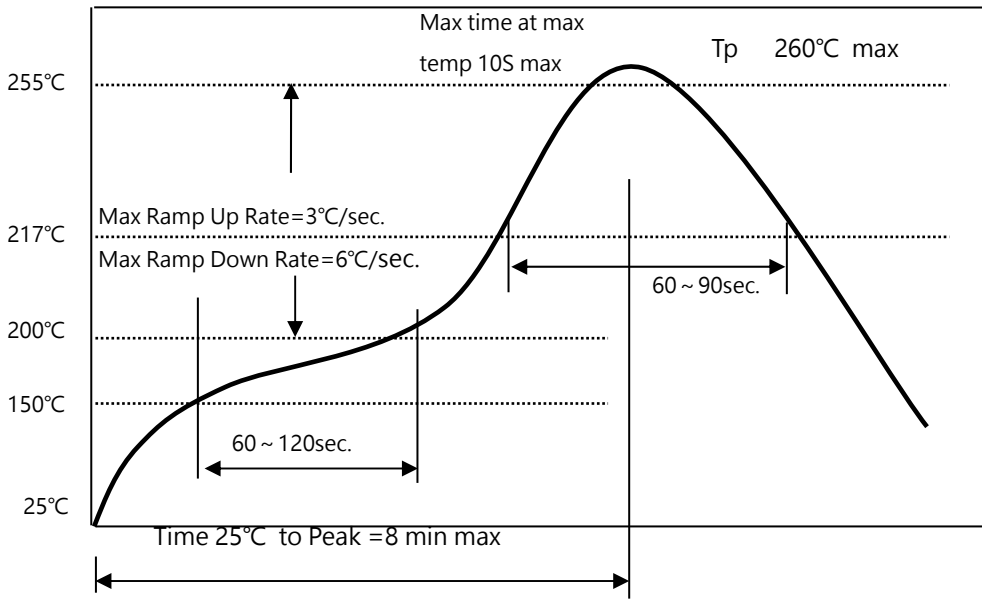

X-ON Electronics

Largest Supplier of Electrical and Electronic Components

Click to view similar products for [Fixed Inductors](#) category:

Click to view products by [MetalLions](#) manufacturer:

Other Similar products are found below :

[CR32NP-100KC](#) [70F224AI](#) [MHQ1005P10NJ](#) [MHQ1005P1N0S](#) [MHQ1005P2N4S](#) [MHQ1005P3N6S](#) [MHQ1005P5N1S](#) [MHQ1005P8N2J](#)
[PE-53601NL](#) [PE-53602NL](#) [PG0936.113NLT](#) [9220-20](#) [9310-16](#) [PM06-2N7](#) [PM06-39NJ](#) [A01TK](#) [1206CS-471XJ](#) [HC2-R47-R](#) [HC8-1R2-R](#)
[HCF1305-3R3-R](#) [1206CS-151XG](#) [RCH664NP-4R7M](#) [RCP1317NP-391L](#) [DH2280-4R7M](#) [DS1608C-106](#) [B10TJ](#) [B82498B3101J000](#) [ELJ-](#)
[RE27NJF2](#) [1812CS-153XJ](#) [1812CS-183XJ](#) [1812CS-223XJ](#) [1812LS-104XJ](#) [1812LS-105XJ](#) [1812LS-124XJ](#) [1812LS-154XJ](#) [1812LS-223XJ](#)
[1812LS-224XJ](#) [1812LS-563XJ](#) [1812LS-683XJ](#) [1812LS-824XJ](#) [NIN-FB101JTR110F](#) [NIN-FB471JTR62F](#) [NIN-FC1R5JTR220F](#) [NIN-](#)
[HCR15JTRF](#) [NIN-HCR33JTRF](#) [NIN-HDR22JTRF](#) [NIN-HDR82JTRF](#) [NIN-HK2N7STRF](#) [NIN-PA150KTR370F](#) [NIN-PB100KTR550F](#)