

FEATURES

- Low profile, high current power supplies.
- Low loss realized with low DCR.
- Ultra low buzz noise, due to composite construction.
- Frequency up to 5MHz.
- Available for automatic mounting in tape and reel package.



APPLICATIONS

- Excellent for power line DC-DC conversion application used in power switching, personal computer and other handheld electronic equipment.

PRODUCT IDENTIFICATION

MHP- 2520 12 -100 - M

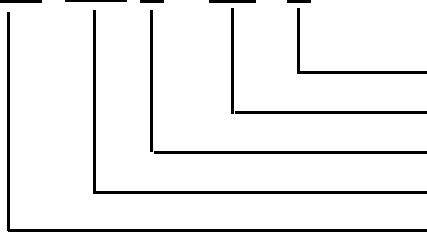

Inductance Tolerance (K:10% ; M:20% ; N:30%)
 Inductance Value 4R7:4.7uH; 100: 10uH; 101:100uH
 Thickness
 Product dimensions
 Series name

SHAPES AND DIMENSIONS

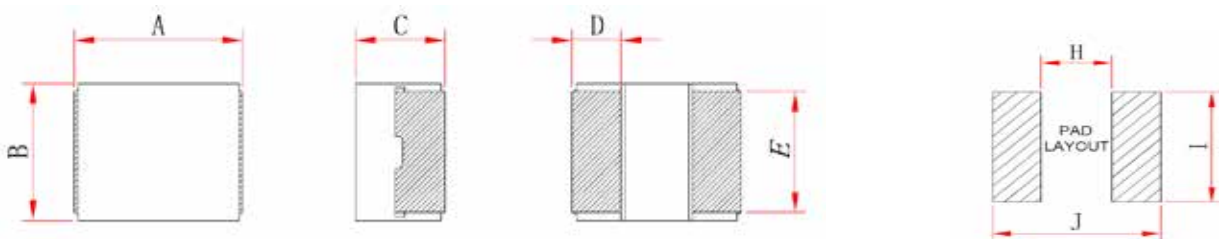

Item	A	B	C	D	E	H	I	J
MHP201610	2.0±0.2	1.6±0.2	1.0 Max	0.5±0.2	1.44	0.9	1.6	2.3
MHP201612	2.0±0.2	1.6±0.2	1.2 Max	0.5±0.2	1.44	0.9	1.6	2.3
MHP252010	2.5±0.2	2.0±0.2	1.0 Max	0.6±0.2	1.84	1.2	2.0	2.8
MHP252012	2.5±0.2	2.0±0.2	1.2 Max	0.6±0.2	1.84	1.2	2.0	2.8

Note: Beyond the above specification also could satisfy the special requirement

ELECTRICAL CHARACTERISTICS

Part No.	Inductance L (uH)	Tolerance (±%)	DCR (mΩ)		I sat (A)		I rms (A)	
			Typ	Max	Max	Typ	Max	Typ
MHP201610-R24M	0.24	20	20	24	4.8	4.3	4.0	3.5
MHP201610-R33M	0.33	20	29	36	4.2	3.7	3.4	3.0
MHP201610-R47M	0.47	20	36	46	3.56	3.2	2.7	2.43
MHP201610-1R0M	1.0	20	63	75	2.8	2.4	2.1	1.9
MHP201610-1R5M	1.5	20	105	137	2.2	2.0	1.8	1.6
MHP201610-2R2M	2.2	20	174	197	1.95	1.75	1.6	1.4
MHP201612-R24M	0.24	20	17	21	5.3	4.8	4.5	4.0
MHP201612-R33M	0.33	20	27	33	4.6	4.0	3.9	3.5
MHP201612-R47M	0.47	20	30	36	3.9	3.5	3.5	3.1
MHP201612-1R0M	1.0	20	60	72	2.9	2.6	2.4	2.2
MHP201612-1R5M	1.5	20	86	112	2.4	2.16	1.9	1.7
MHP201612-2R2M	2.2	20	146	186	2.1	1.7	1.5	1.35
MHP252010-R33M	0.33	20	19	26	5.3	4.77	4.4	4.0
MHP252010-R47M	0.47	20	28	41	4.5	4.05	3.5	3.1
MHP252010-R68M	0.68	20	31	45	4.3	3.6	3.3	3.0
MHP252010-1R0M	1.0	20	58	65	3.55	3.2	2.8	2.52
MHP252010-1R5M	1.5	20	76	95	3.0	2.7	2.2	1.98
MHP252010-2R2M	2.2	20	104	113	2.6	2.34	1.8	1.62
MHP252012-R33M	0.33	20	15	17	5.80	5.22	5.5	4.95
MHP252012-R47M	0.47	20	23	28	5.0	4.5	4.5	4.0
MHP252012-1R0M	1.0	20	48	55	3.8	3.3	3.1	2.7
MHP252012-1R5M	1.5	20	61	70	2.9	2.61	2.7	2.43
MHP252012-2R2M	2.2	20	92	105	2.5	2.2	2.3	2.0

If you require another part number please contact with us.

Note 1: Referenced ambient temperature 20°C .

Note 2: Test Condition :1MHz ,1.0 Vrms.

Note 3: I sat (Typ) : DC current (A) that will cause L0 to drop approximately 30%

I sat (Max) : DC current (A) that will cause L0 to drop 30% Max

I rms (Typ) : DC current (A) that will cause an approximate ΔT of 40°C

I rms (Max) : DC current (A) that will cause an ΔT of 40°C Max

Note 4: Operating temperature range includes self-temperature rise. Storage Temperature Range:-40°C to+125°C

Note 5: The rated current as listed is either the saturation current or the heating current depending on which value is lower.

Note: Beyond the above specification also could satisfy the special requirement

Typical performance curves :

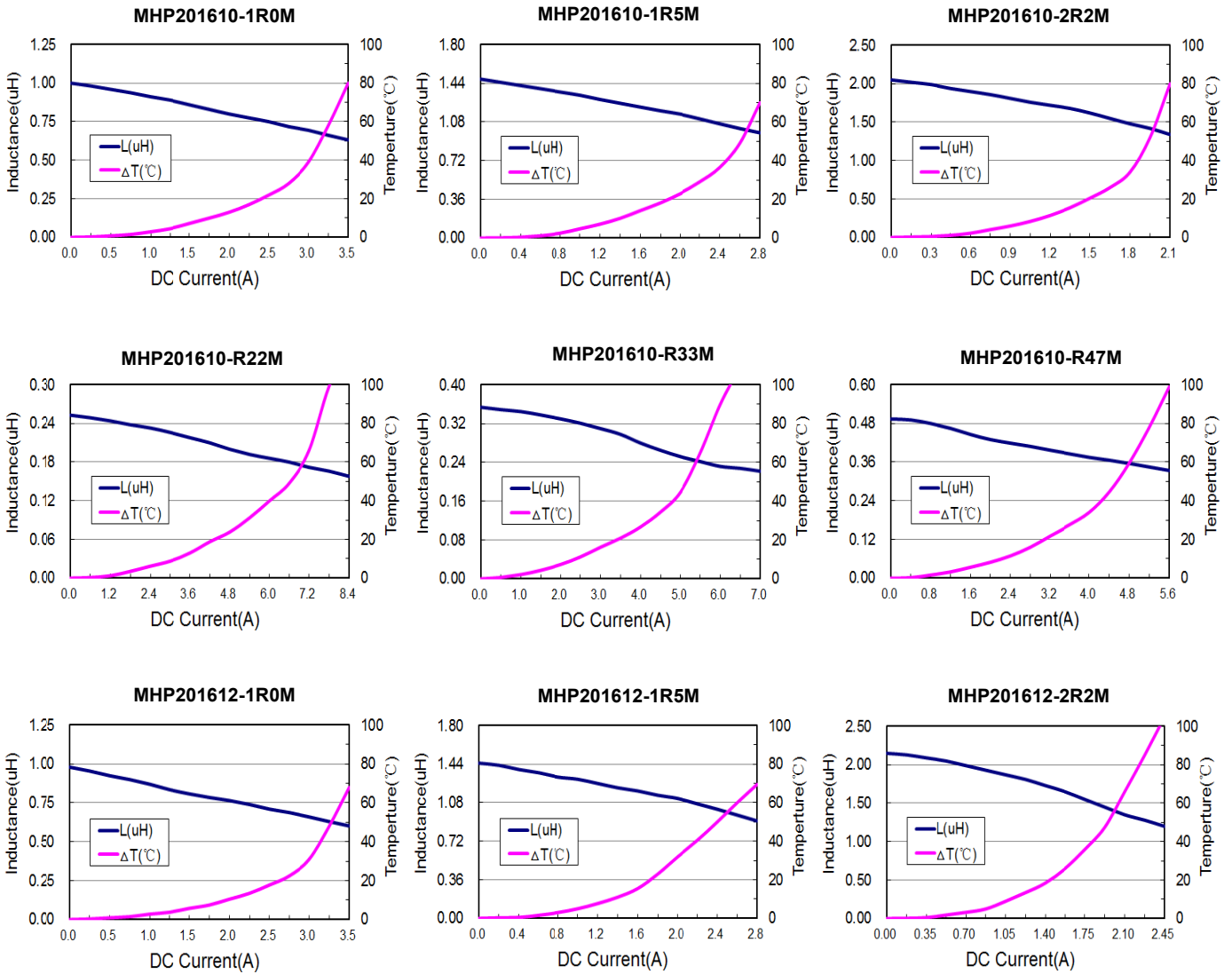

Typical performance curves :

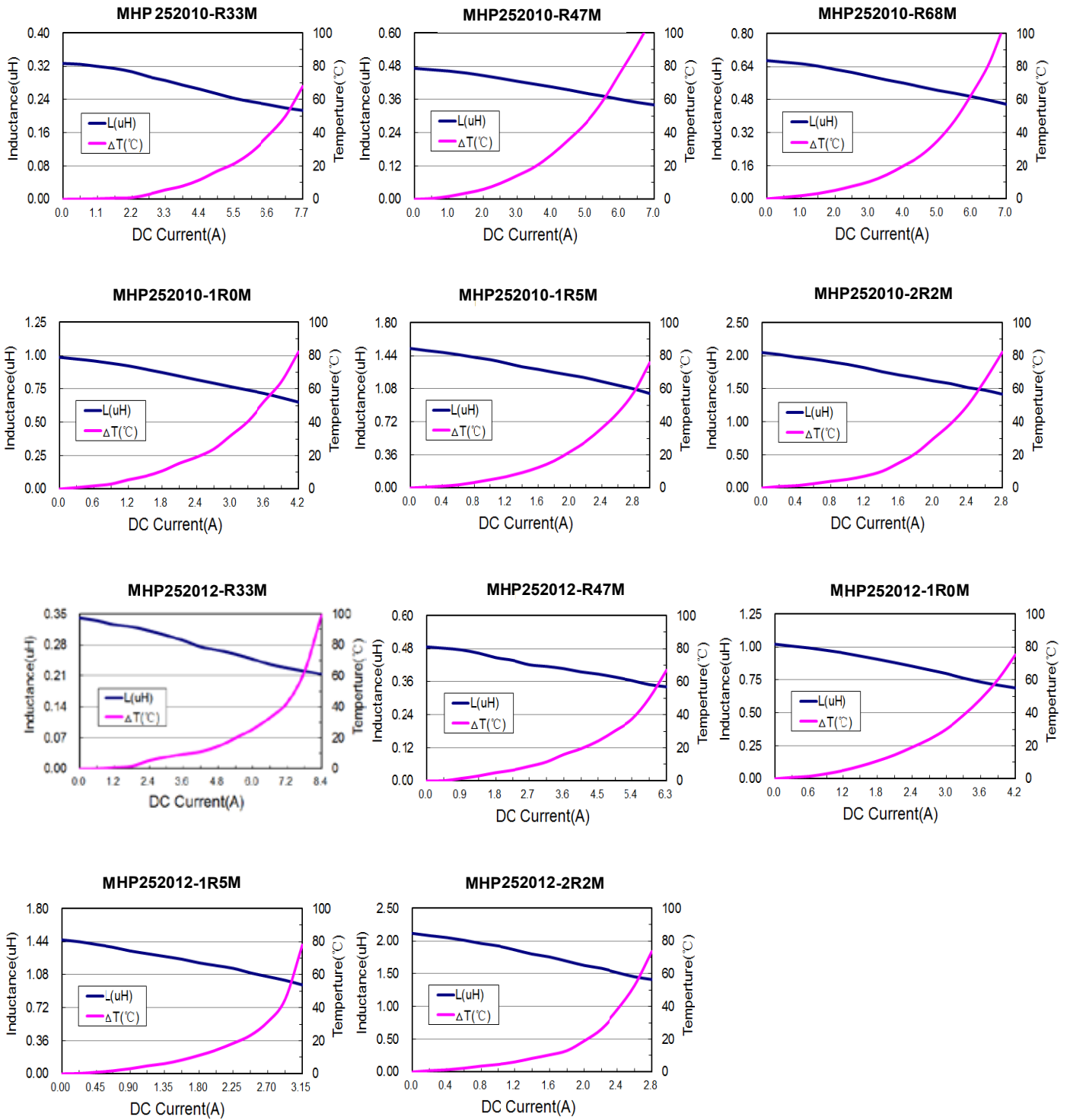

RELIABILITY TEST

FOR SMT/SMD and other similar types

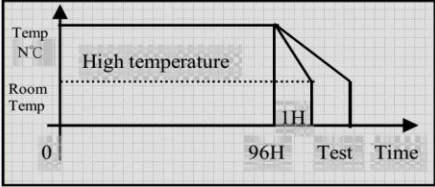
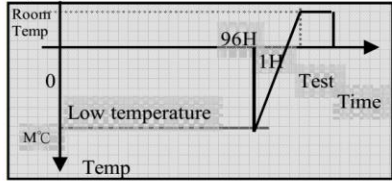
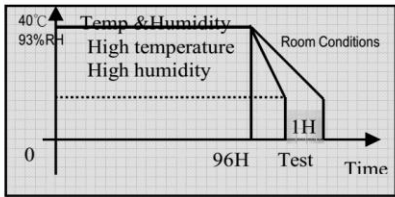
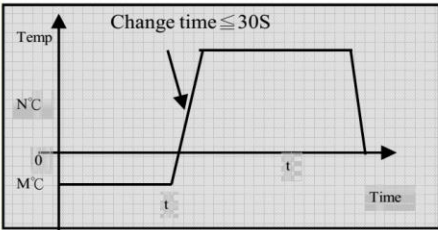
Item (項目)	Required Characteristics (要求)	Test Method / Condition (測試方法)
High temperature Storage test Reference documents: MIL-STD-202G Method 108A 高溫儲存試驗	1.No case deformation or change in appearance. 2. $\Delta L/L \leq 10\%$ or 15% 3. $\Delta Q/Q \leq 30\%$ 4. $\Delta DCR/DCR \leq 10\%$ N:依據產品規格設定 1.無明顯的外觀缺陷 2.感值變化不超過10%或者15% 3.品質因數變化不超過30% 4.直流電阻變化不超過10%	Temperature: $N \pm 2^\circ\text{C}$ Time : 96 ± 2 hours Tested not less than 1 hour, nor more than 2 hours at room temperature.  溫度: $N \pm 2^\circ\text{C}$ 時間: 96 ± 2 小時 樣品在室溫下放置1小時,不超2小時必須測試.
Low temperature Storage test Reference documents: IEC 68-2-1A 6.1 6.2 低溫儲存試驗	1.No case deformation or change in appearance. 2. $\Delta L/L \leq 10\%$ or 15% 3. $\Delta Q/Q \leq 30\%$ 4. $\Delta DCR/DCR \leq 10\%$ M:依據產品規格設定 1.無明顯的外觀缺陷 2.感值變化不超過10%或者15% 3.品質因數變化不超過30% 4.直流電阻變化不超過10%	Temperature: $M \pm 2^\circ\text{C}$ Time : 96 ± 2 hours Tested not less than 1 hour, nor more than 2 hours at room temperature.  溫度: $M \pm 2^\circ\text{C}$ 時間: 96 ± 2 小時 樣品在室溫下放置1小時,不超2小時必須測試.
Humidity test Reference documents: MIL-STD-202G Method 103B 濕度測試	1.No case deformation or change in appearance. 2. $\Delta L/L \leq 10\%$ or 15% 3. $\Delta Q/Q \leq 30\%$ 4. $\Delta DCR/DCR \leq 10\%$ 1.無明顯的外觀缺陷 2.感值變化不超過10%或者15% 3.品質因數變化不超過30% 4.直流電阻變化不超過10%	Temperature: $40 \pm 2^\circ\text{C}$, Humidity: $93 \pm 3\% \text{RH}$ Time : 96 ± 2 hours Tested not less than 1 hour, nor more than 2 hours at room temperature.  溫度: $40 \pm 2^\circ\text{C}$, 溼度: $93 \pm 3\% \text{RH}$ 時間 : 96 ± 2 hours 樣品在室溫下放置1小時,不超2小時必須測試.
Thermal shock test Reference documents: MIL-STD-202G Method 107G 熱衝擊測試	1.No case deformation or change in appearance. 2. $\Delta L/L \leq 10\%$ or 15% 3. $\Delta Q/Q \leq 30\%$ 4. $\Delta DCR/DCR \leq 10\%$ For T: weight $\leq 28\text{g}$: 15Min; M:低溫設定 $28\text{g} \leq \text{weight} \leq 136\text{g}$: 30Min N:高溫設定 1.無明顯的外觀缺陷 2.感值變化小於10%或者15% 3.品質因數變化小於30% 4.直流電阻變化小於10%	First $M^\circ\text{C}$ for T time, last $N^\circ\text{C}$ for T time as 1 cycle. Go through 20 cycles.  從 -40°C 作用 T 分鐘,然後溫度衝擊到 125°C 作用 T 分鐘,作為一個循環,共作用 20 次.

FOR SMT/SMD and other similar types

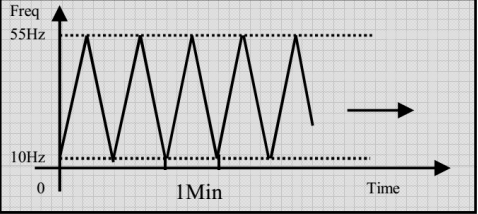
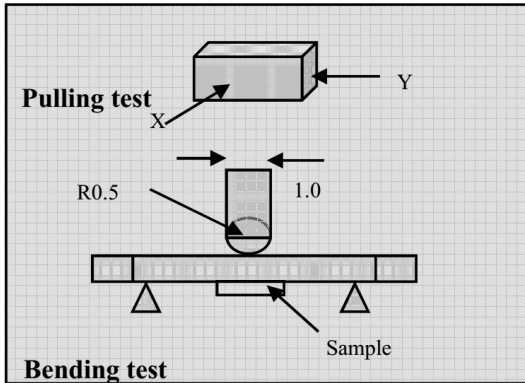
Item (項目)	Required Characteristics (要求)	Test Method / Condition (測試方法)
Solderability test Reference documents: MIL-STD-202G Method 208H IPC J-STD-002C 可焊性測試	Terminals area must have 95% min. solder coverage 端子必須有95%以上著錫	1. Dip pads in flux then dip in solder pot at $245\pm 5^{\circ}\text{C}$ for 5 seconds. 2. Solder: lead free 3. Flux: rosin flux 1. 端子浸入助焊劑, 然後浸入 $245\pm 5^{\circ}\text{C}$ 錫爐中5秒 2. 焊料: 無鉛焊料 3. 助焊劑: 松香助焊劑
Heat endurance of Reflow soldering Reference documents: IPC J-STD-020D 過再流焊測試	1. No case deformation or change in appearance. 2. $\Delta L/L \leq 10\%$ or 15% 3. $\Delta Q/Q \leq 30\%$ 4. $\Delta \text{DCR}/\text{DCR} \leq 10\%$ 1. 無明顯的外觀缺陷 2. 感值變化不超過10%或者15% 3. 品質因數變化不超過30% 4. 直流電阻變化不超過10%	1. Refer to the next page reflow curve Go through 3 times 2. The peak temperature : $260+0/-5^{\circ}\text{C}$ 1. 參照下頁回流焊曲線過三次 2. 峰值溫度為: $260+0/-5^{\circ}\text{C}$
Vibration test Reference documents: MIL-STD-202G Method 201A 振動測試	1. No case deformation or change in appearance. 2. $\Delta L/L \leq 10\%$ 3. $\Delta Q/Q \leq 30\%$ 4. $\Delta \text{DCR}/\text{DCR} \leq 10\%$ 1. 無明顯的外觀缺陷 2. 感值變化不超過10% 3. 品質因數變化不超過30% 4. 直流電阻變化不超過10%	Apply frequency 10~55Hz. 1.5mm amplitude in each of perpendicular direction for 2 hours. (total 6 hours)  用10~55Hz 振動頻率, 振幅1.5mm, 振動周期為1min/cycle. 沿X,Y,Z方向各振動2小時.(共6小時)
Drop test Reference documents: MIL-STD-202G Method 203C 落下試驗	1. No case deformation or change in appearance. 2. $\Delta L/L \leq 10\%$ 3. $\Delta Q/Q \leq 30\%$ 4. $\Delta \text{DCR}/\text{DCR} \leq 10\%$ 1. 無明顯的外觀缺陷 2. 感值變化不超過10% 3. 品質因數變化不超過30% 4. 直流電阻變化不超過10%	Packaged & Drop down from 1m with 981m/s^2 (100G) attitude In 1 angle 1 ridges & 2 surfaces orientations. 將產品包裝後從1米高度自然落下至試驗板上 1角1稜2面
Terminal strength push test Reference documents: JIS C 5321 :1997 端子強度試驗	Pulling test: Define: A: sectional area of terminal $0.5\text{mm}^2 < A \leq 1.2\text{mm}^2$ force $\geq 20\text{N}$ time : 10sec $1.2\text{mm}^2 < A$ force $\geq 40\text{N}$ time: 10sec Bending test: Soldering the products on PCB, after the pulling test and bending test ,terminal should not pull off 推力測試: 定義: A: 焊接端子截面積 $0.5\text{mm}^2 < A \leq 1.2\text{mm}^2$ 推力 $\geq 20\text{N}$ 時間: 10S $1.2\text{mm}^2 < A$ 推力 $\geq 40\text{N}$ 時間10S 彎折測試: 將產品焊於PCB上, 分別經過推力測試和彎折測試後, 端子不會發生松脫	Bend the testing PCB at middle point, the deflection shall be 2mm  將PCB對中彎折, 到達撓度2mm.
Resistance to solvent test Reference documents: IEC 68-2-45:1993 耐溶劑性試驗	No case deformation or change in appearance, or obliteration of marking 無外觀破壞及標記破損	To dip parts into IPA solvent for $5\pm 0.5\text{Min}$, then drying them at room temp for 5Min, at last, to brushing making 10 times. 在IPA溶劑中浸泡 5 ± 0.5 分鐘, 室溫下乾燥5分鐘, 然後擦拭10次.

Physical characteristic tests (物理特性試驗)

Packaging

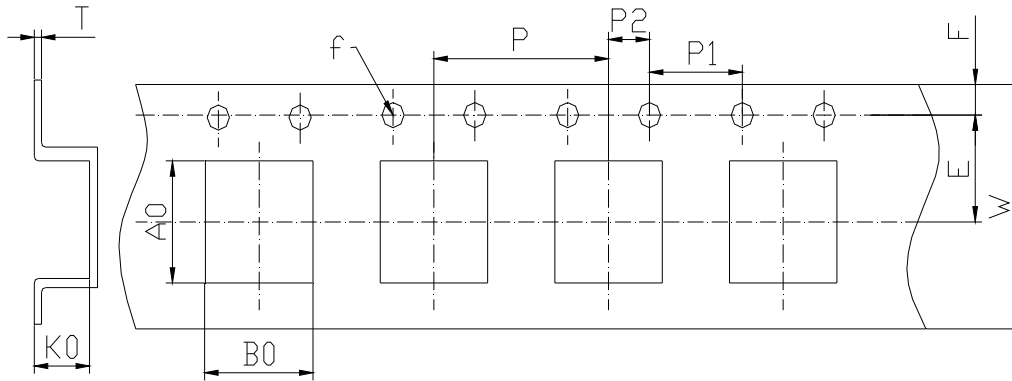

SIZE	A0	B0	E	F	f	P	P1	P2	W	T	K0
MHP201610	2.65	2.23	5.50	1.75	1.50	4.00	4.00	2.00	8.00	0.25	1.30
MHP201612	2.65	2.23	5.50	1.75	1.50	4.00	4.00	2.00	8.00	0.25	1.50
MHP252010	2.73	2.23	5.50	1.75	1.50	4.00	4.00	2.00	8.00	0.25	1.30
MHP252012	2.73	2.23	5.50	1.75	1.50	4.00	4.00	2.00	8.00	0.25	1.50

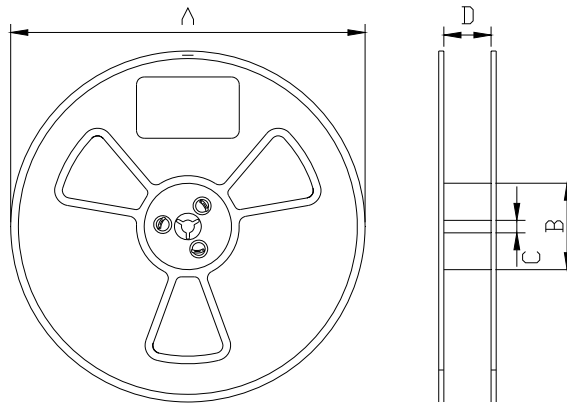

SIZE	A	B	C	D	Reel/PCS
MHP2016	330	100	13	12.5	3000
MHP2520	330	100	13	12.5	3000

Note: Beyond the above specification also could satisfy the special requirement

X-ON Electronics

Largest Supplier of Electrical and Electronic Components

Click to view similar products for [Fixed Inductors](#) category:

Click to view products by [Me-TECH](#) manufacturer:

Other Similar products are found below :

[MLZ1608M6R8WTD25](#) [MLZ1608N6R8LT000](#) [MLZ1608N3R3LTD25](#) [MLZ1608N3R3LT000](#) [MLZ1608N150LT000](#)

[MLZ1608M150WTD25](#) [MLZ1608M3R3WTD25](#) [MLZ1608M3R3WT000](#) [MLZ1608M150WT000](#) [MLZ1608A1R5WT000](#)

[MLZ1608N1R5LT000](#) [B82432C1333K000](#) [PCMB053T-1R0MS](#) [PCMB053T-1R5MS](#) [PCMB104T-1R5MS](#) [CR32NP-100KC](#) [CR32NP-](#)

[151KC](#) [CR32NP-180KC](#) [CR32NP-181KC](#) [CR32NP-1R5MC](#) [CR32NP-390KC](#) [CR32NP-3R9MC](#) [CR32NP-680KC](#) [CR32NP-820KC](#)

[CR32NP-8R2MC](#) [CR43NP-390KC](#) [CR43NP-560KC](#) [CR43NP-680KC](#) [CR54NP-181KC](#) [CR54NP-470LC](#) [CR54NP-820KC](#) [CR54NP-8R5MC](#)

[MGDQ4-00004-P](#) [MGDU1-00016-P](#) [MHL1ECTTP18NJ](#) [MHL1JCTTD12NJ](#) [PE-51506NL](#) [PE-53601NL](#) [PE-53630NL](#) [PE-53824SNLT](#) [PE-](#)

[62892NL](#) [PE-92100NL](#) [PG0434.801NLT](#) [PG0936.113NLT](#) [PM06-2N7](#) [PM06-39NJ](#) [HC2LP-R47-R](#) [HC2-R47-R](#) [HC3-2R2-R](#) [HC8-1R2-R](#)