



BRIGHTTEK
BRIGHTTEK (EUROPE) LIMITED

Brighten up The World With LED!



ISO/TS 16949:2009



BS EN ISO 14001:2004



QC 080000 IECQ HSPM

PRODUCT DATASHEET



- ▶ PLCC4 SMD with IC
- ▶ 5050 IC 1.6t
- ▶ Red/Green/Blue

NOM59S06IC



Release Date: 19 May 2021 Version: A1.0

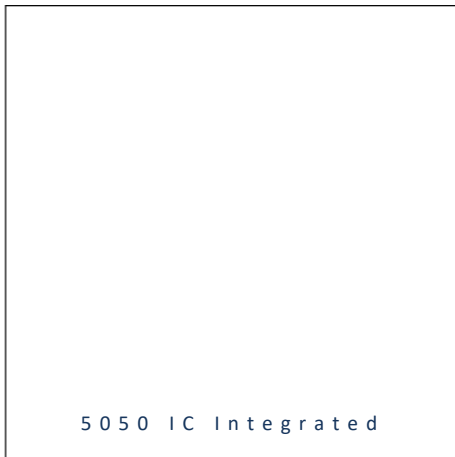

5050 IC Integrated

5050 IC-Integrated

RoHS
Compliant



FEATURES:

- **Package:** PLCC6 Top View LED Package with Integrated IC
- **Forward Current:** 20/20/20mA* * in order of Red/Green/Blue
- **Power Supply Voltage (typ.):** +3.5~+5.3V
- **Luminous Intensity (typ.):** 600/1550/400mcd
- **Colour:** Red/Green/Blue
- **Materials:**
 - Resin: Silicone (Water Clear)
 - L/F Finish: Ag Plated
- **IC Feature:** Cascading port transmission signal by single line. Built-in signal reshaping circuit, after wave reshaping to the next driver, ensure wave-form distortion not accumulate. Built-in electric reset circuit and power lost reset circuit. Any two point the distance does not exceed 3m transmission signal without any increase circuit. Send data at speeds of 800Kbps. When the refresh rate is 30fps, cascade number are not less than 1024 points.
- **Pixel:** Each pixel of the three primary colour can achieve 256 brightness display, completed 16777216 full colour display, and scan frequency not less than 400Hz/s.
- **Soldering methods:** Reflow soldering
- **Preconditioning:** acc. to JEDEC Level 3
- **Packing:** 12mm tape with Max.1000pcs/reel, ø180mm (7")

APPLICATIONS:

- Telecommunication
- Indicator
- Home Appliance
- Decoration Lighting
- Full Colour LED Strip
- Gaming Device
- Guardrail Tube

General Description:

N0M59S061C is an intelligent control LED light source that the control circuit and RGB chips are integrated in a package of 5050 components. It internal include intelligent digital port data latch and signal reshaping amplification drive circuit. Also include a precision internal oscillator and a 12V voltage programmable constant current control part, effectively ensuring the pixel point light color height consistent.

The data transfer protocol uses single NZR communication mode. After the pixel power-on reset, the DIN port receive data from controller, the first pixel collects initial 24bit data then sent to the internal data latch, the other data which reshaping by the internal signal reshaping amplification circuit sent to the next cascade pixel through the DO port. After transmission for each pixel the signal to reduce 24bit. pixel adopt auto reshaping transmit technology, making the pixel cascade number is not limited the signal transmission, only depend on the speed of signal transmission.

LED with low driving voltage, environmental protection and energy saving, high brightness, scattering angle is large, good consistency, low power, long life and other advantages. The control chip integrated in LED above becoming more simple circuit, small volume, convenient installation.

Features and Benefits:

- The control circuit and the LED share the only power source.
- Control circuit and RGB chip are integrated in a package of 5050 components, form a complete control of pixel point.
- Built-in signal reshaping circuit, after wave reshaping to the next driver, ensure wave-form distortion not accumulate.
- Built-in electric reset circuit and power lost reset circuit.
- Each pixel of the four primary color can achieve 256 brightness display, completed 16777216 color full color display, and scan frequency not less than 400Hz/s.
- Cascading port transmission signal by single line.
- Any two point the distance does not exceed 3m transmission signal without any increase circuit.
- When the refresh rate is 30fps, cascade number are not less than 1024 points.
- Send data at speeds of 800Kbps.
- The color of the light were highly consistent and cost-effective.

CHARACTERISTICS:

Absolute Maximum Characteristics (Ta=25°C)

Parameter	Symbol	Ratings	Unit
Power Supply Voltage	V _{DD}	+3.5~+5.3	V
Logic Input Voltage	V _I	-0.4~V _{DD} +0.4	V
Operating Temperature	T _{OPR}	-40~+85	°C
Storage Temperature	T _{STG}	-40~+105	°C

Electrical & Optical Characteristics (Ta=25°C, V_{DD}=5V, V_{SS}=0V)

Parameter	Symbol	Values			Unit	Test Condition	
		Min.	Typ.	Max.			
Chip Supply Voltage	V _{DD}	3.5	5.2	6.0	V	---	
R/G/B Port Input Voltage	V _{DS(MAX)}	---	---	9	V	---	
Signal Input Flip Threshold	V _{IH}	3.4	---	---	V	V _{DD} =5V	
	V _{IL}	---	---	1.6	V		
The Frequency of PWM	F _{PWM}	---	1.2	---	KHz	---	
Static Power Consumption	I _{DD}	---	1	---	mA	---	
Luminous Intensity	R	I _v	500	---	700	mcd	I _F =20mA
	G		1300	---	1800		
	B		300	---	500		
Dominant Wavelength	R	λ _D	620	---	625	nm	I _F =20mA
	G		520	---	525		
	B		465	---	470		
Forward Voltage	R	V _F	2.0	---	2.4	V	I _F =20mA
	G		2.8	---	3.2		
	B		2.8	---	3.2		
Viewing Angle	2θ _{1/2}	---	120	---	deg	I _F =20mA	

Dynamic Characteristics (Ta=25°C)

Parameter	Symbol	Values			Unit	Test Condition
		Min.	Typ.	Max.		
Speed of Data Transmission	F _{DIN}	---	800	---	KHz	---
DIN/FDIN to DO Delay	I _{DLY}	---	500	000	ns	---
R/G/B Output Current	I _R /I _G /I _B	---	13.2	---	mA	V _R /V _G /V _B =3V

OUTLINE DIMENSION:

Package Dimension:

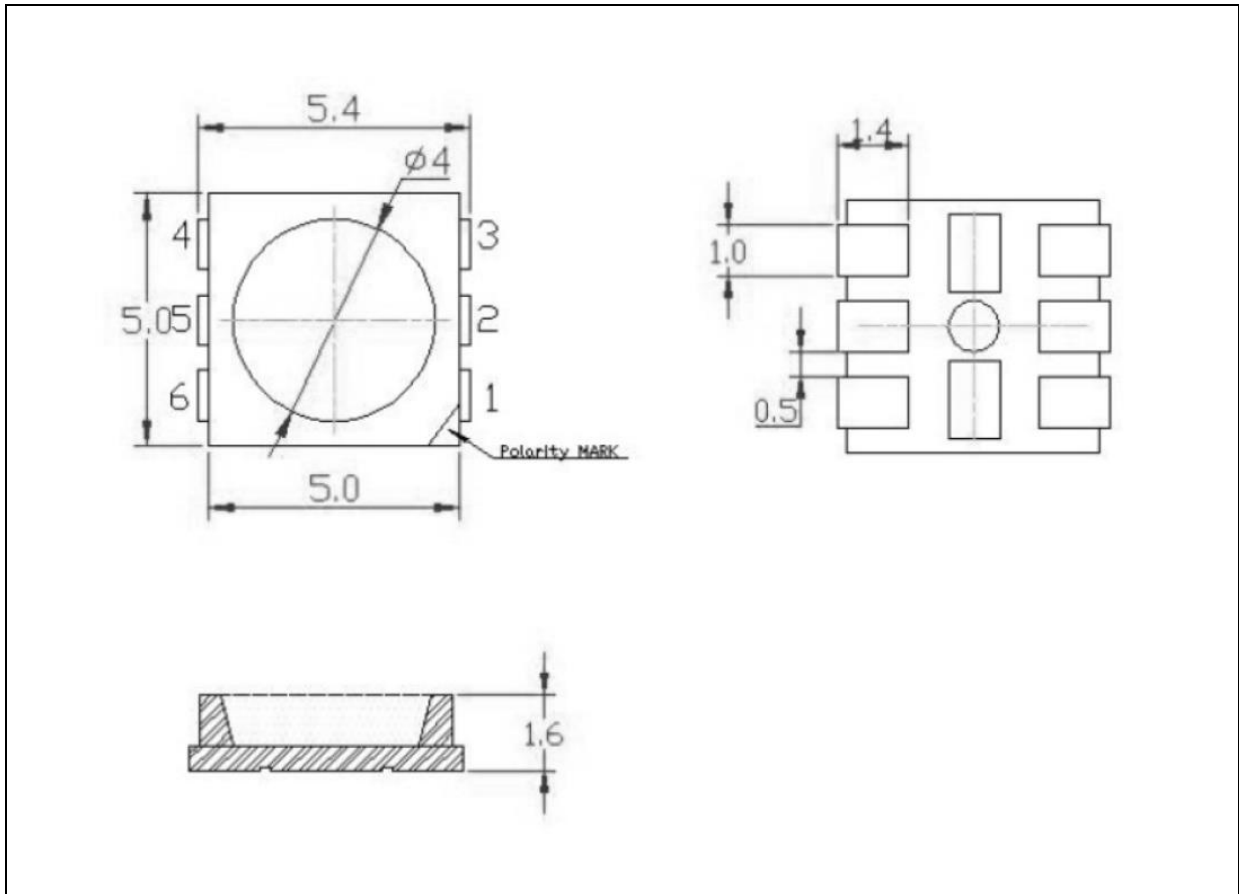

1. All dimensions are in millimetre (mm).
2. Tolerance $\pm 0.2\text{mm}$, unless otherwise noted.

Recommended Soldering Pad Dimension:

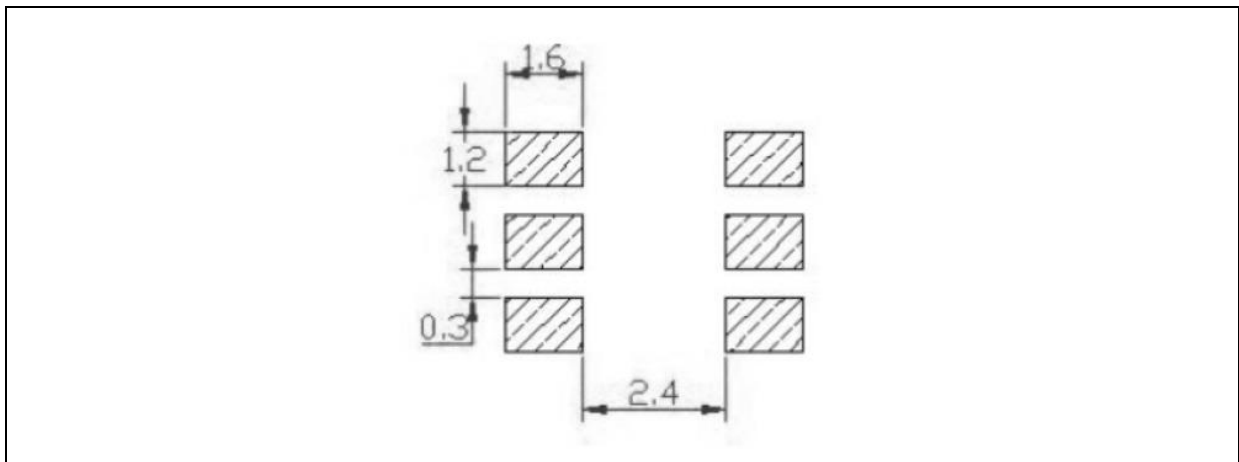

1. Dimensions are in millimetre (mm).
2. Tolerance $\pm 0.1\text{mm}$ with angle tolerance $\pm 0.5^\circ$.

PIN CONFIGURATION:

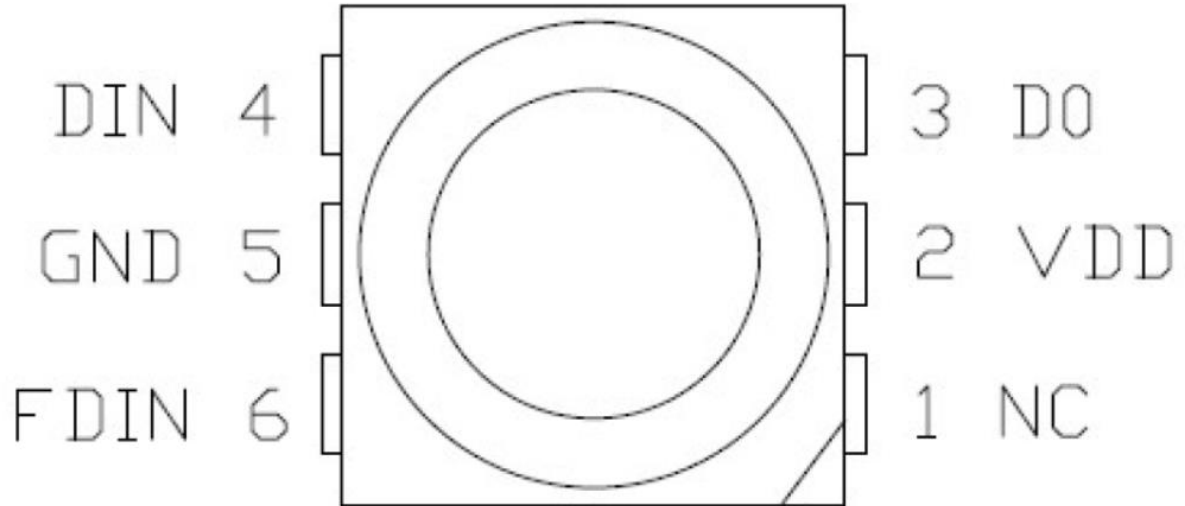

No.	Symbol	Function Description
1	NC	No Connection
2	VDD	Power Supply LED +5V
3	DO	Control Data Signal Output
4	DIN	Control Data Signal Input
5	GND	Signal Ground and Power Ground
6	FDIN	Backup Data Signal Input

Function Description:

1. Timing Wave Form:

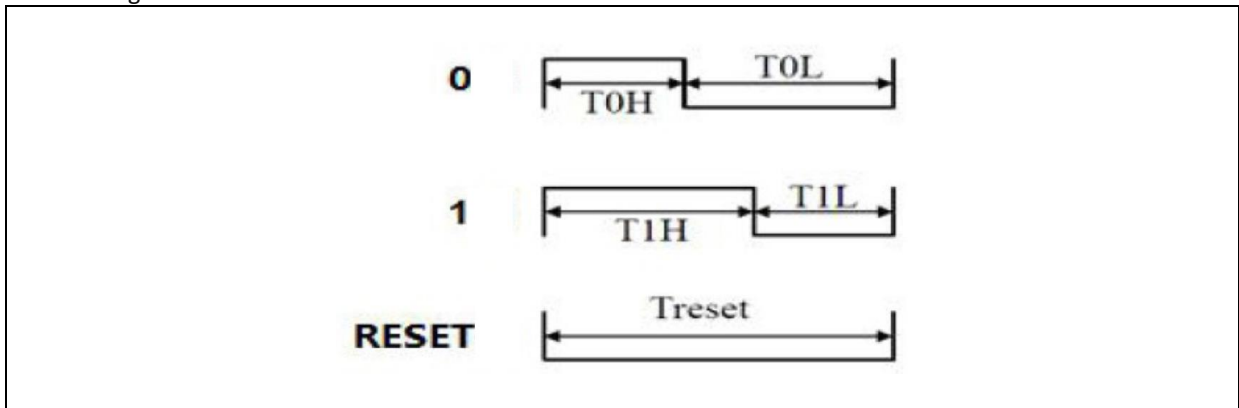

2. Low Speed Mode:

Item	Description	Typical	Allowance
TOH	0 Code, High Voltage Time	0.3 μ s	$\pm 0.05\mu$ s
T1H	1 Code, High Voltage Time	0.9 μ s	$\pm 0.05\mu$ s
TOL	0 Code, Low Voltage Time	0.9 μ s	$\pm 0.05\mu$ s
T1L	1 Code, Low Voltage Time	0.3 μ s	$\pm 0.05\mu$ s
TRST	Reset Code, Low Voltage Time	>80 μ s	---

3. Mode of Data Transmission:

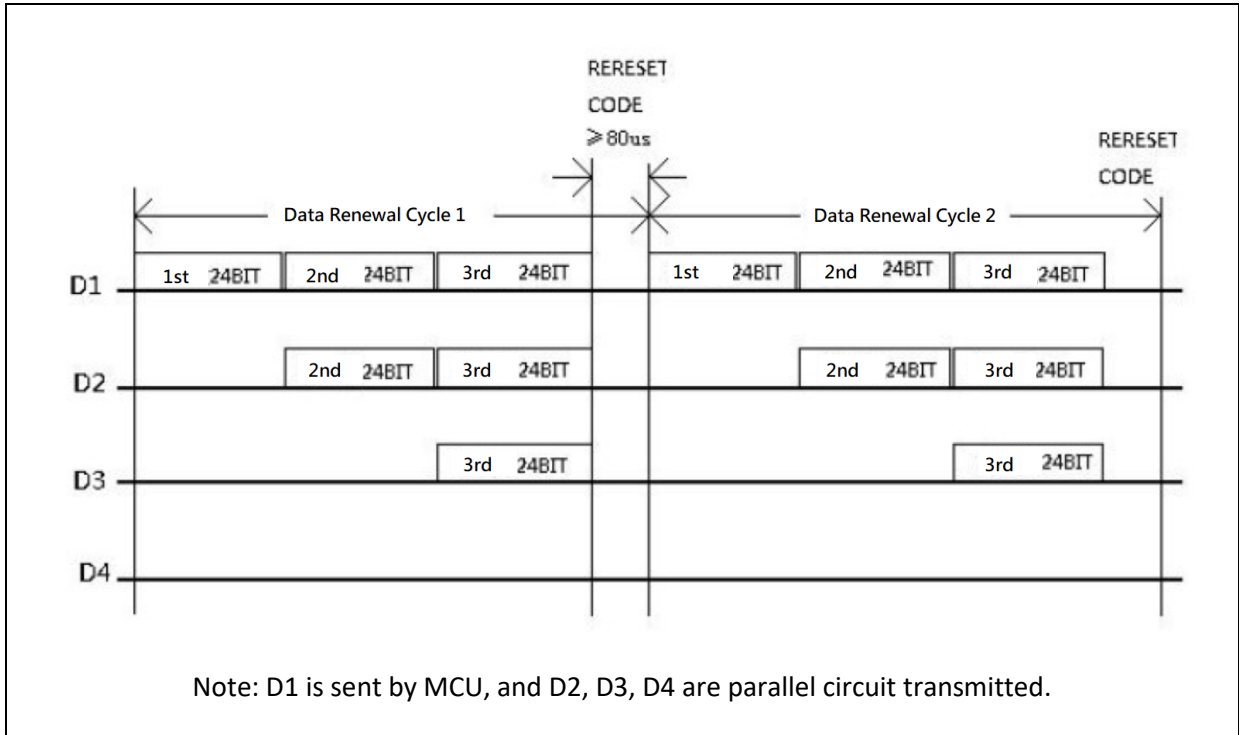

4. Data Transmission:

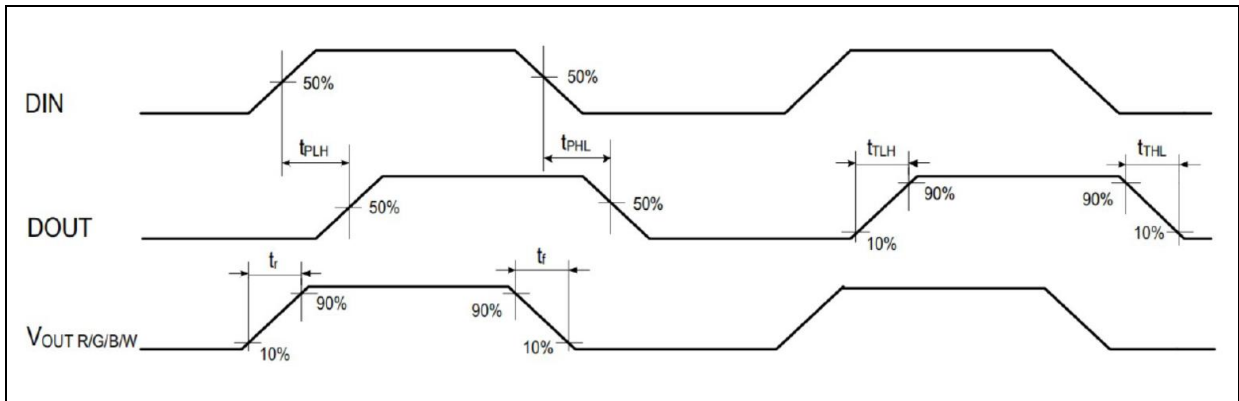

5. Low Speed Mode:

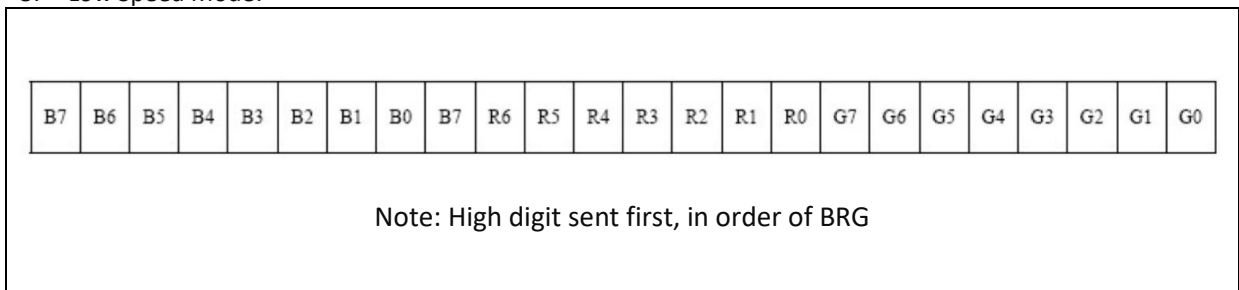

6. Typical Application Circuit:

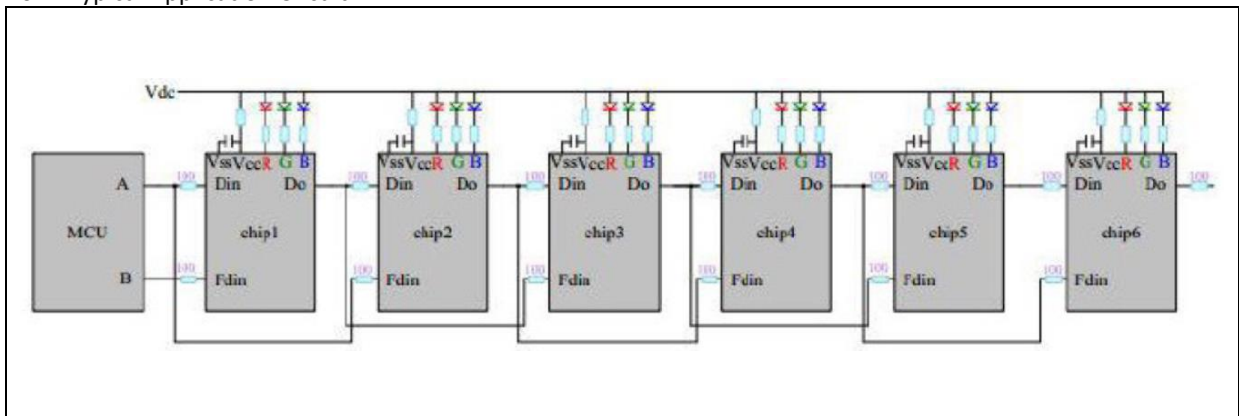

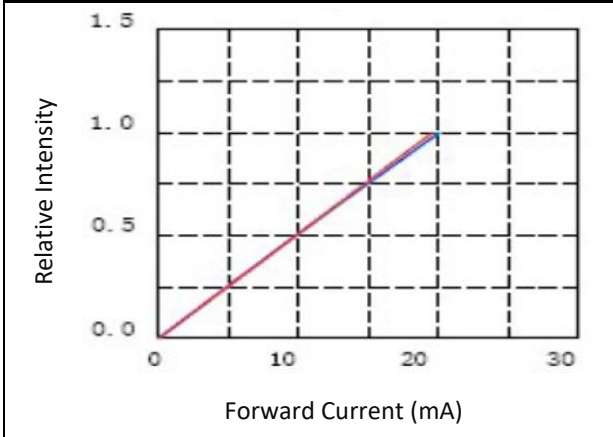
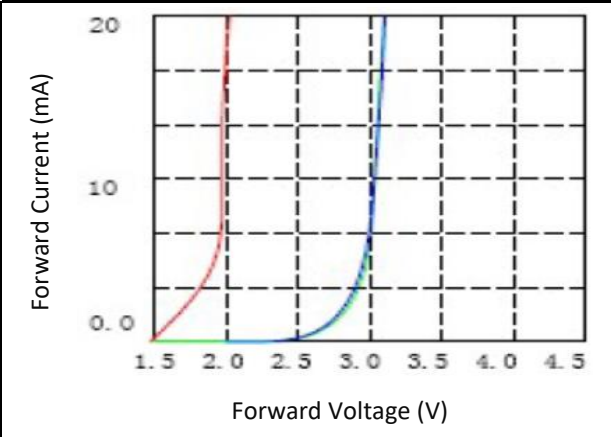
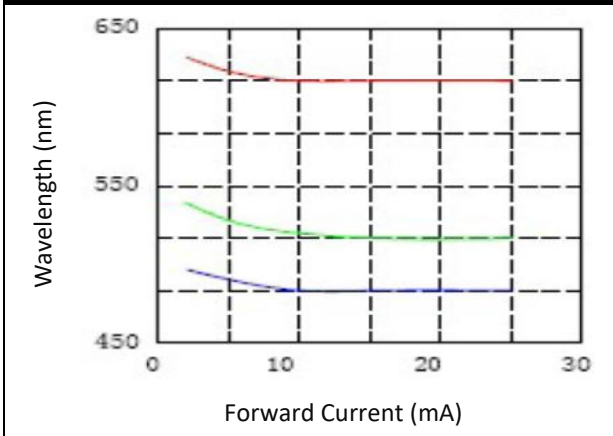
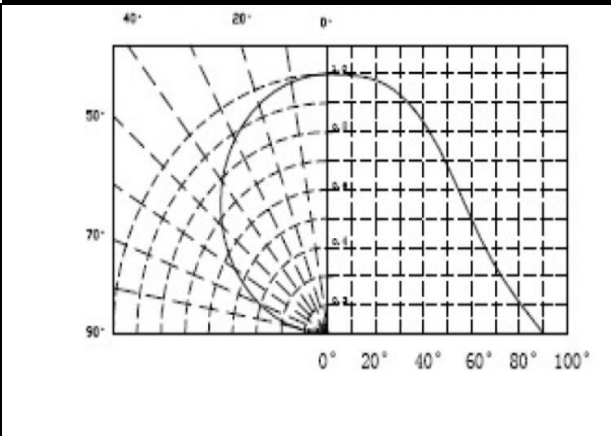
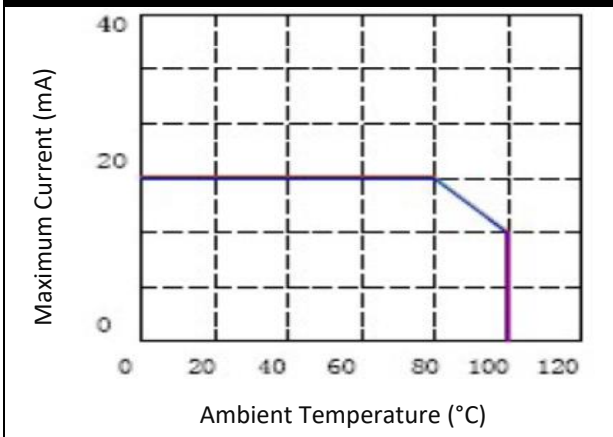
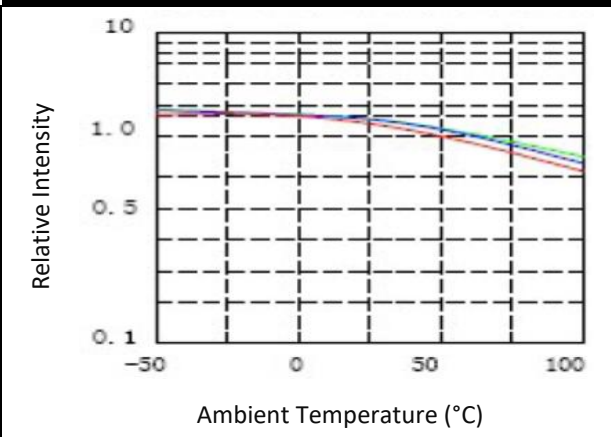
ELECTRO-OPTICAL CHARACTERISTICS:
Relative Intensity v.s. Forward Current

Forward Current v.s. Forward Voltage

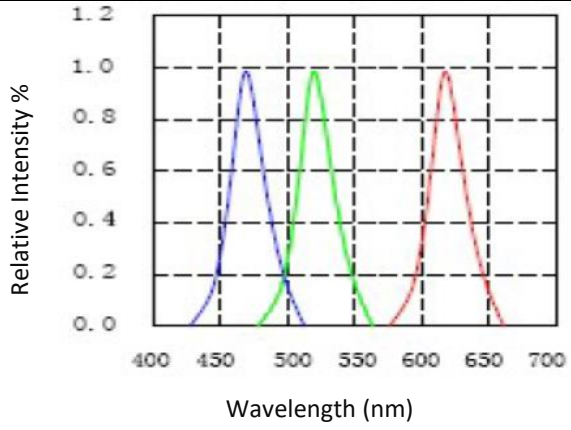
Forward Current v.s. Wavelength

Diagram of Radiation

Temperature Derating Chart

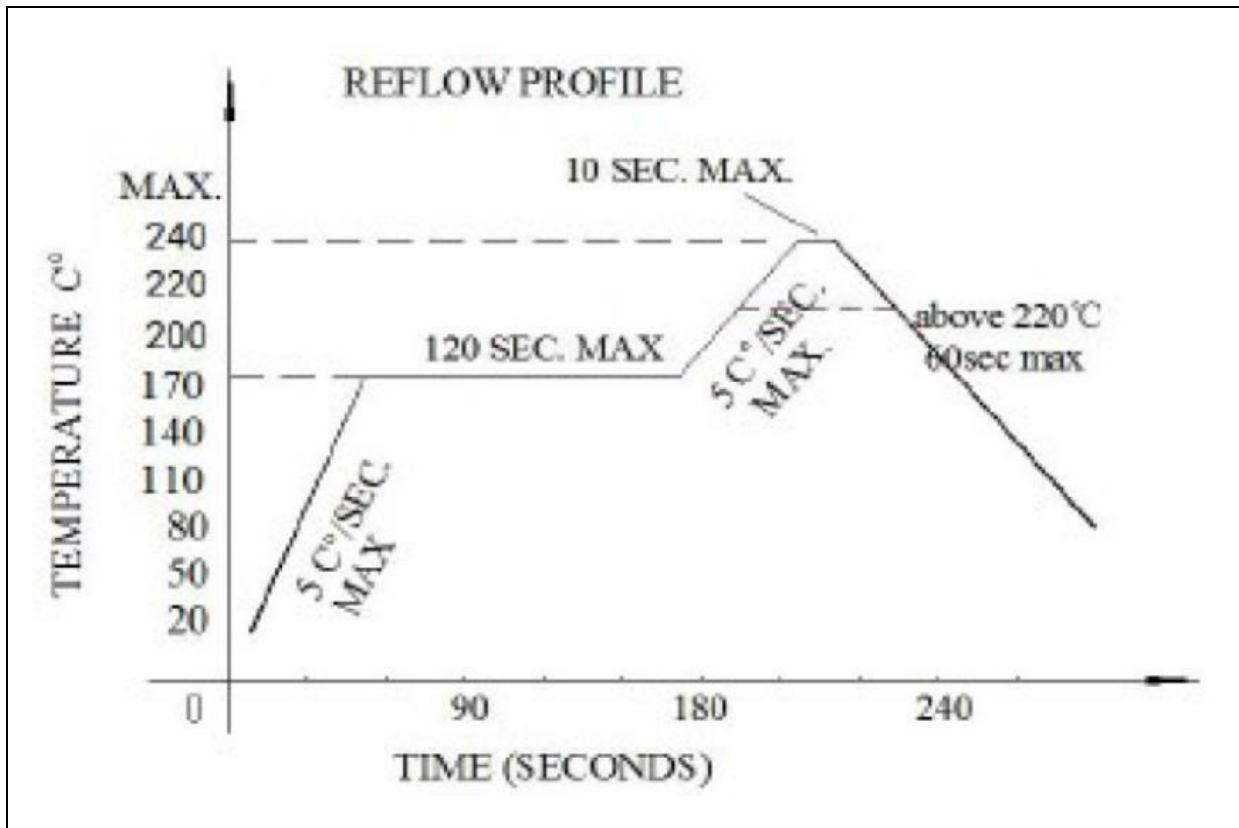
Relative Intensity Flux v.s. Ambient Temperature

Relative Intensity v.s. Wavelength



RECOMMENDED SOLDERING PROFILE:

Lead-free Solder IR Reflow:



Note:

1. The maximum soldering temperature should be limited to 240°C.
2. Maxima reflow soldering: 2 times.
3. Before, during, and after soldering, should not apply stress on the components and PCB board.

PACKING SPECIFICATION:

Reel Dimension:

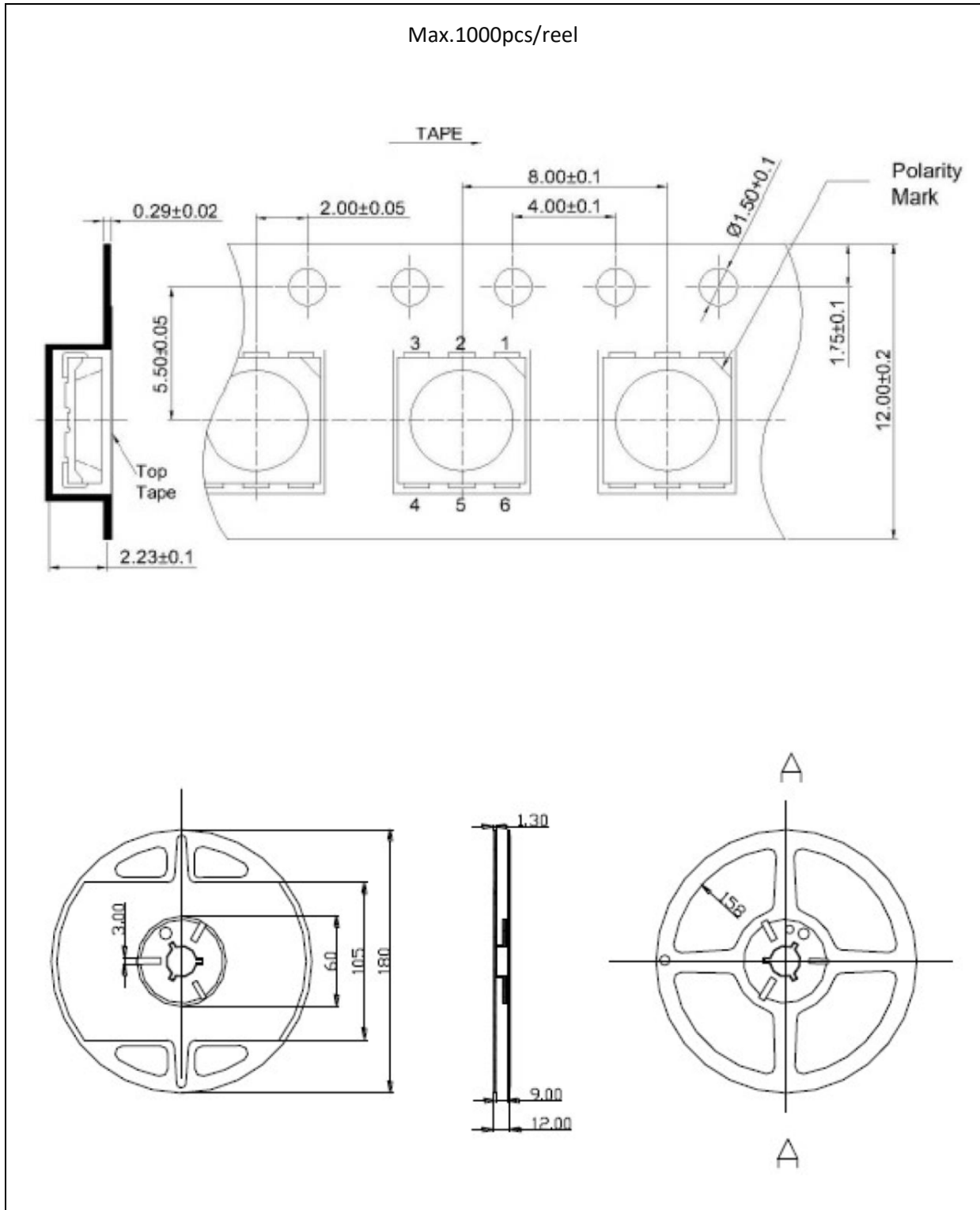

PRECAUTIONS OF USE:

Storage:

It is recommended to store the products in the following conditions:

- Humidity: 60% R.H. Max.
- Temperature: 5°C~30°C (41°F ~86°F).

Shelf life in sealed bag: 12 months at 5°C~30°C and <60% R.H.

Once the package is opened, the products should be used within 48 hours. Otherwise, they should be kept in a damp-proof box with desiccating agent stored at R.H.<10% and apply baking before use.

Over-Current Proof:

Must apply resistors for protection otherwise slight voltage shift will cause big current change and burn-out will happen.

Baking:

It is recommended to bake the LED before soldering if the pack has been unsealed for longer than 24hrs. The suggested baking conditions are as followings:

- 60±3°C x 6hrs and <5%RH, taped / reel package.

It's normal to see slight color fading of carrier (light yellow) after baking in process.

Cleaning:

Use alcohol-based cleaning solvents such as isopropyl alcohol to clean the LED carrier / package. Avoid putting any stress force directly on to the LED lens.

ESD (Electrostatic Discharge):

Static Electricity or power surge will damage the LED. Use of a conductive wrist band or anti-electrostatic glove is recommended when handling the LED all time. All devices, equipment, machinery, work tables, and storage racks must be properly grounded.

REVISION RECORD:

Version	Date	Summary of Revision
A1.0	19/05/2021	Datasheet set-up.

X-ON Electronics

Largest Supplier of Electrical and Electronic Components

Click to view similar products for [Standard LEDs - SMD category](#):

Click to view products by [MGT Brightek manufacturer](#):

Other Similar products are found below :

[LTST-C190KYKT](#) [LTST-C19GD2WT](#) [LTW-170ZDC](#) [LTW-M140SZS40](#) [LTW-M140ZVS](#) [598-8110-100F](#) [598-8610-202F](#) [91-21SUBCS400-A6TR7](#) [AAAF5060QBFSEEZGS](#) [APT1608QGW](#) [99-213/R6C-AR2T1B/2C](#) [SML-LX0606SISUGC/A](#) [SML-LXR851SIUPGUBC](#) [LT1ED53A](#) [APFA3010SURKCGKQBDC](#) [APHK1608VGCA](#) [APT2012QGW](#) [LTST-008BGEW](#) [LTW-010DCG](#) [LTW-020ZDCG](#) [LTW-21TS5](#) [LTW-220DS5](#) [598-8330-117F](#) [65-21SYGC/S530-E3/TR8](#) [CMDA20AYAA7D1S](#) [95-21SURCS530-A3TR10](#) [598-8040-100F](#) [598-8070-100F](#) [598-8140-100F](#) [598-8610-200F](#) [SML-LXR851SGSIC-TR](#) [SML-512PWT86A](#) [SMF-2432GYC-TR](#) [EASV3015RGYA0](#) [95-21UYC-S530-A5-TR7](#) [LTST-C190KFKT-5A](#) [LTST-C194TBKT-5A](#) [CLX6E-FKC-CH1M1D1BB7C3D3](#) [SML-LXL0805USBC-TR](#) [SML-LX2835SYSUGCTR](#) [LTW-M670ZVS-M5](#) [APA2106ZGC/G](#) [CLMXB-FKA-CbcfghjnpACBB79463](#) [VFA1101W-5AY3B2-TR](#) [LCB P473-P2R2-3J7L-1-Z](#) [91-21VGC/S556/S68/TR10/S370](#) [LW A67C-S2U1-FK0KM0](#) [LW A673-P1S1-FK0PM0](#) [BL-HE1G033B-TRB](#) [5988B90107F](#)