

## 4 MHz PWM 6A Buck Regulator with HyperLight Load<sup>®</sup>

### Features

- Input Voltage: 2.7V to 5.5V
- 6A Output Current
- Up to 93% Efficiency and 81% at 1 mA
- 24  $\mu$ A Typical Quiescent Current
- 4 MHz PWM Operation in Continuous Mode
- Ultra-Fast Transient Response
- Power Good
- Programmable Soft-Start
- Low Voltage Output Ripple
  - 14 mV<sub>PP</sub> Ripple in HyperLight Load Mode
  - 5 mV Output Voltage Ripple in Full PWM Mode
- Fully Integrated MOSFET Switches
- 0.01  $\mu$ A Shutdown Current
- Thermal Shutdown and Current Limit Protection
- Output Voltage as Low as 0.65V
- 20-pin 4 mm x 5 mm DFN
- -40°C to +125°C Junction Temperature Range

### Applications

- 5V POL Supplies
- $\mu$ C/ $\mu$ P, FPGA and DSP Power
- Test and Measurement Systems
- Barcode Readers
- Set-Top Box, Modems, and DTV
- Distributed Power Systems
- Networking Systems

### General Description

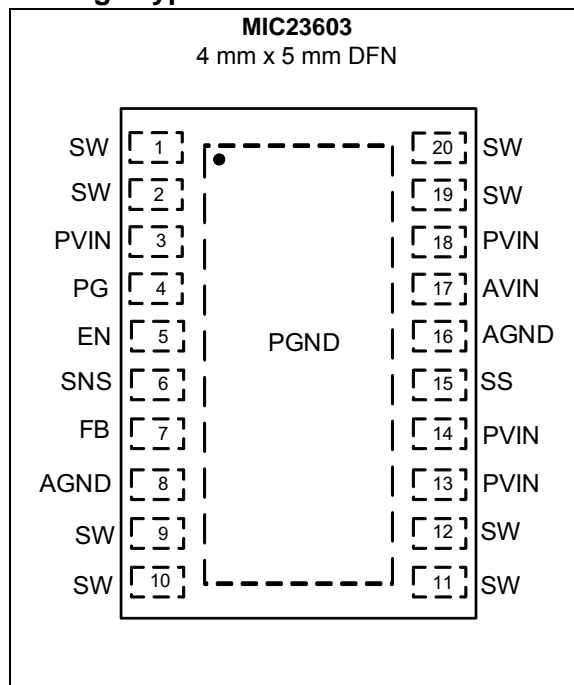
The MIC23603 is a high-efficiency 4 MHz 6A synchronous buck regulator with HyperLight Load<sup>®</sup> mode. HyperLight Load provides very high efficiency at light loads and ultra-fast transient response which is perfectly suited for supplying processor core voltages. An additional benefit of this proprietary architecture is very low output ripple voltage throughout the entire load range with the use of small output capacitors. The tiny 4 mm x 5 mm DFN package saves precious board space and requires few external components.

The MIC23603 is designed for use with a very small inductor, down to 0.33  $\mu$ H, and an output capacitor as small as 47  $\mu$ F that enables a sub-1 mm height.

The MIC23603 has a very low quiescent current of 24  $\mu$ A and achieves as high as 81% efficiency at 1 mA. At higher loads, the MIC23603 provides a constant switching frequency around 4 MHz while achieving peak efficiencies up to 93%.

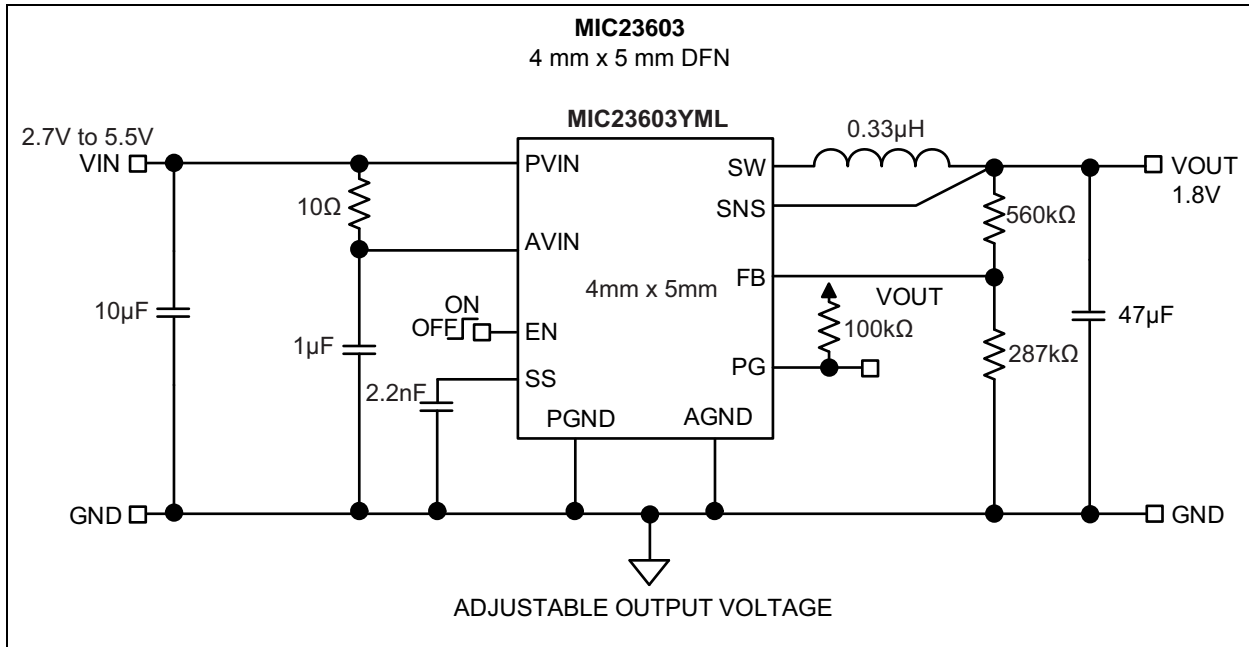
The MIC23603 is available in 20-pin 4 mm x 5mm DFN package with an operating junction temperature range from -40°C to +125°C.

### Package Type

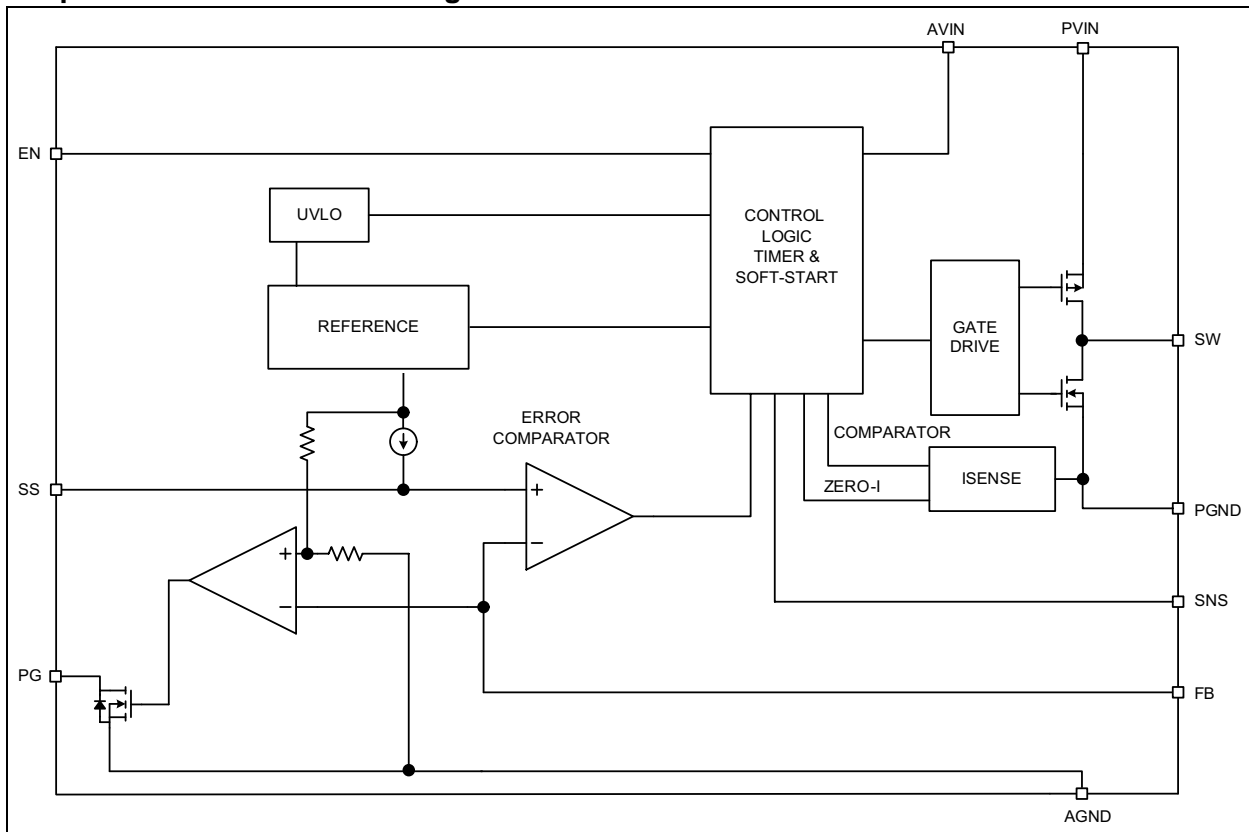


# MIC23603

## Typical Application Circuit



## Simplified Functional Block Diagram



## 1.0 ELECTRICAL CHARACTERISTICS

### Absolute Maximum Ratings †

Supply Voltage ( $V_{IN}$ )	+6V
Sense ( $V_{SNS}$ )	+6V
Output Switch Voltage	+6V
Enable Input Voltage ( $V_{EN}$ )	-0.3V to $V_{IN}$
ESD Rating (Note 1)	ESD Sensitive

### Operating Ratings ††

Supply Voltage ( $V_{IN}$ )	+2.7V to +5.5V
Enable Input Voltage ( $V_{EN}$ )	0V to $V_{IN}$
Output Voltage Range ( $V_{SNS}$ )	+0.65V to +3.6V

† Notice: Exceeding absolute maximum rating may cause damage to the device.

†† Notice: The device is not guaranteed to function outside its operating rating.

**Note 1:** Devices are ESD sensitive. Handling precautions are recommended. Human body model, 1.5 k $\Omega$  in series with 100 pF.

### ELECTRICAL CHARACTERISTICS (Note 1)

**Electrical Characteristics:** Unless otherwise indicated,  $T_A = +25^\circ\text{C}$ ;  $V_{IN} = V_{EN} = 3.6\text{V}$ ;  $V_{OUT} = 1.8\text{V}$ ;  $L = 0.33\ \mu\text{H}$ ;  $C_{OUT} = 47\ \mu\text{F} \times 2$  unless otherwise specified. **Bold** values indicate  $-40^\circ\text{C} \leq T_J \leq +125^\circ\text{C}$ .

Parameters	Min.	Typ.	Max.	Units	Conditions
Supply Voltage Range	<b>2.7</b>	—	<b>5.5</b>	V	—
Undervoltage Lockout Threshold	<b>2.2</b>	2.5	<b>2.8</b>	V	Turn-on
Undervoltage Lockout Hysteresis	—	270	—	mV	—
Quiescent Current	—	24	<b>45</b>	$\mu\text{A}$	$I_{OUT} = 0\ \text{mA}$ , $SNS > 1.2 \times V_{OUT}$ Nominal
Shutdown Current	—	0.01	<b>5</b>	$\mu\text{A}$	$V_{EN} = 0\text{V}$ , $V_{IN} = 5.5\text{V}$
Feedback Voltage	<b>0.605</b>	0.62	<b>0.636</b>	V	—
Current Limit	<b>6.5</b>	12	<b>16</b>	A	$SNS = 0.9 \times V_{OUTNOM}$
Output Voltage Line Regulation	—	0.3	—	%/ $V$	$V_{IN} = 3.6\text{V}$ to $5.5\text{V}$ if $V_{OUTNOM} < 2.5\text{V}$ , $I_{LOAD} = 20\ \text{mA}$
					$V_{IN} = 4.5\text{V}$ to $5.5\text{V}$ if $V_{OUTNOM} \geq 2.5\text{V}$ , $I_{LOAD} = 20\ \text{mA}$
Output Voltage Load Regulation	—	0.3	—	%	$20\ \text{mA} < I_{LOAD} < 500\ \text{mA}$ , $V_{IN} = 3.6\text{V}$ if $V_{OUTNOM} < 2.5\text{V}$
					$20\ \text{mA} < I_{LOAD} < 500\ \text{mA}$ , $V_{IN} = 5.0\text{V}$ if $V_{OUTNOM} \geq 2.5\text{V}$
	—	0.7	—	%	$20\ \text{mA} < I_{LOAD} < 1\text{A}$ , $V_{IN} = 3.6\text{V}$ if $V_{OUTNOM} < 2.5\text{V}$
					$20\ \text{mA} < I_{LOAD} < 1\text{A}$ , $V_{IN} = 5.0\text{V}$ if $V_{OUTNOM} \geq 2.5\text{V}$
PWM Switch ON-Resistance	—	0.03	—	$\Omega$	$I_{SW} = 1000\ \text{mA}$ PMOS
	—	0.025	—		$I_{SW} = -1000\ \text{mA}$ NMOS

**Note 1:** Specification for packaged product only.

# MIC23603

## ELECTRICAL CHARACTERISTICS (CONTINUED)(Note 1)

**Electrical Characteristics:** Unless otherwise indicated,  $T_A = +25^\circ\text{C}$ ;  $V_{IN} = V_{EN} = 3.6\text{V}$ ;  $V_{OUT} = 1.8\text{V}$ ;  $L = 0.33\ \mu\text{H}$ ;  $C_{OUT} = 47\ \mu\text{F} \times 2$  unless otherwise specified. **Bold** values indicate  $-40^\circ\text{C} \leq T_J \leq +125^\circ\text{C}$ .

Parameters	Min.	Typ.	Max.	Units	Conditions
Maximum Frequency	—	4	—	MHz	$I_{OUT} = 300\ \text{mA}$
Soft Start Time	—	1200	—	$\mu\text{s}$	$V_{OUT} = 90\%$ , $C_{SS} = 2.2\ \text{nF}$
Power Good Threshold	85	90	95	%	% of $V_{NOMINAL}$
Power Good Hysteresis	—	20	—	%	—
Power Good Pull Down	—	—	200	mV	$V_{SNS} = 90\% V_{NOMINAL}$ , $I_{PG} = 1\ \text{mA}$
Enable Threshold	<b>0.4</b>	0.8	<b>1.2</b>	V	Turn-On
Enable Input Current	—	0.1	<b>2</b>	$\mu\text{A}$	—
Overtemperature Shutdown	—	160	—	$^\circ\text{C}$	—
Overtemperature Shutdown Hysteresis	—	20	—	$^\circ\text{C}$	—

**Note 1:** Specification for packaged product only.

## TEMPERATURE SPECIFICATIONS (Note 1)

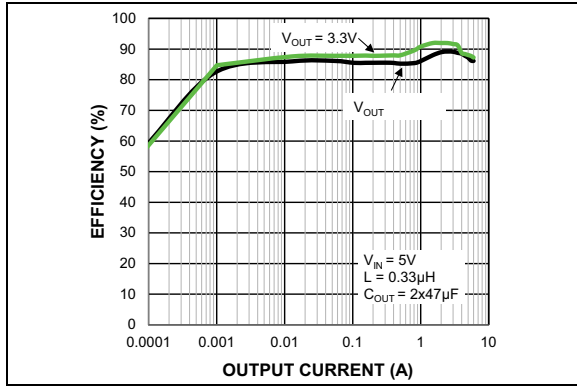
Parameters	Sym.	Min.	Typ.	Max.	Units	Conditions
<b>Temperature Ranges</b>						
Junction Operating Temperature	$T_J$	-40	—	+125	°C	—
Storage Temperature Range	$T_A$	-65	—	+150	°C	—
<b>Package Thermal Resistances</b>						
Thermal Resistance, 4 x 5 DFN-20Ld	$\theta_{JA}$	—	44.1	—	°C/W	—

**Note 1:** The maximum allowable power dissipation is a function of ambient temperature, the maximum allowable junction temperature and the thermal resistance from junction to air (i.e.,  $T_A$ ,  $T_J$ ,  $\theta_{JA}$ ). Exceeding the maximum allowable power dissipation will cause the device operating junction temperature to exceed the maximum +125°C rating. Sustained junction temperatures above +125°C can impact the device reliability.

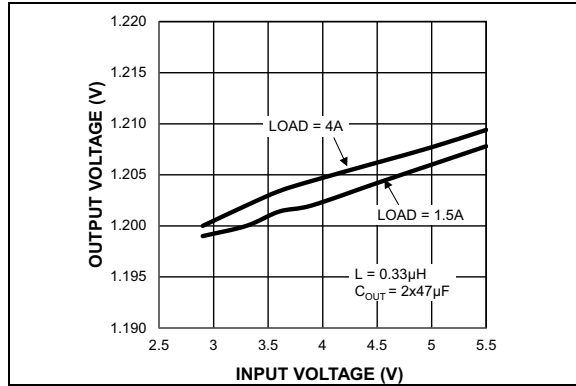
# MIC23603

## 2.0 TYPICAL PERFORMANCE CURVES

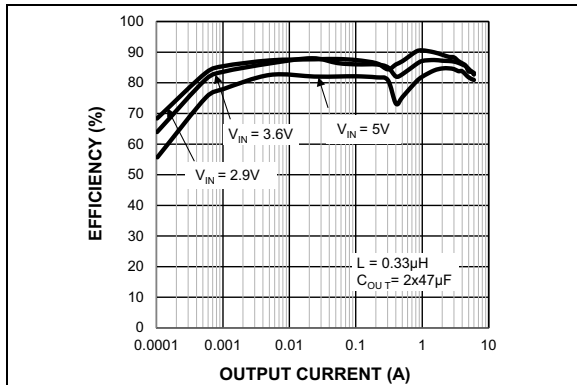
**Note:** The graphs and tables provided following this note are a statistical summary based on a limited number of samples and are provided for informational purposes only. The performance characteristics listed herein are not tested or guaranteed. In some graphs or tables, the data presented may be outside the specified operating range (e.g., outside specified power supply range) and therefore outside the warranted range.



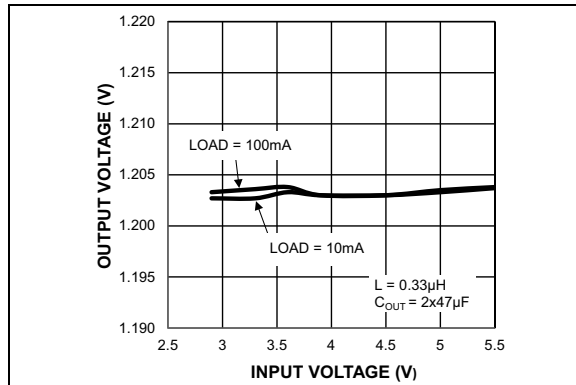
**FIGURE 2-1:** Efficiency vs. Output Current.



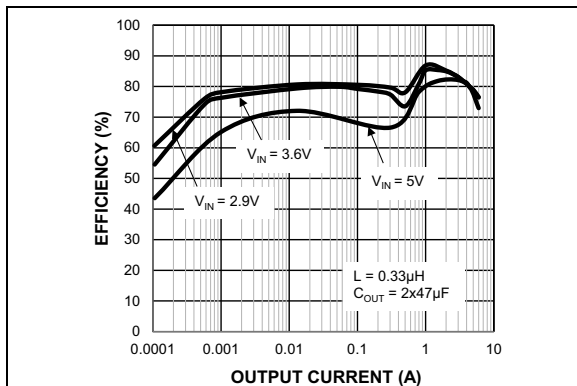
**FIGURE 2-4:** Output Voltage vs. Input Voltage.



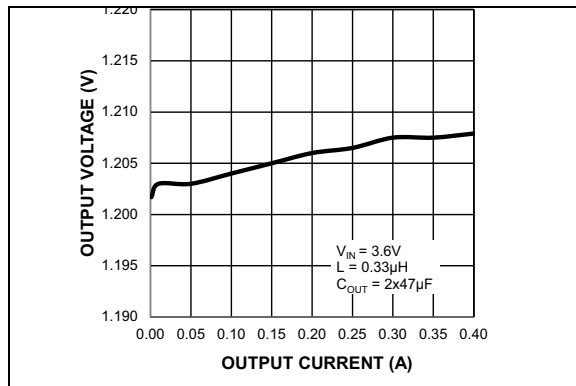
**FIGURE 2-2:** Efficiency vs. Output Current  $V_{OUT} = 1.8V$ .



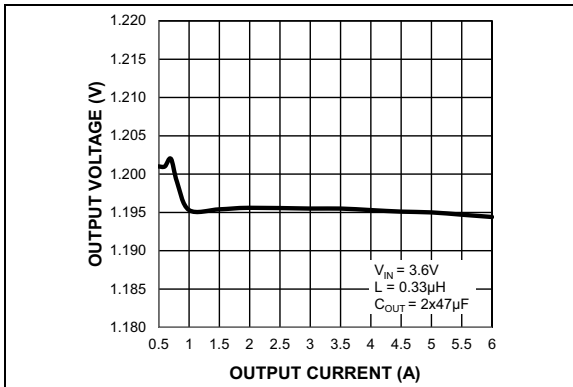
**FIGURE 2-5:** Output Voltage vs. Input Voltage.



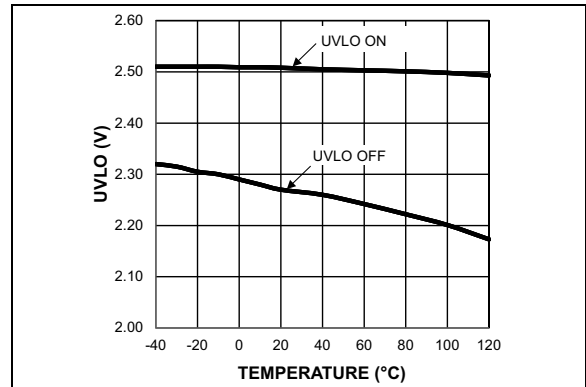
**FIGURE 2-3:** Efficiency vs. Output Current  $V_{OUT} = 1.2V$ .



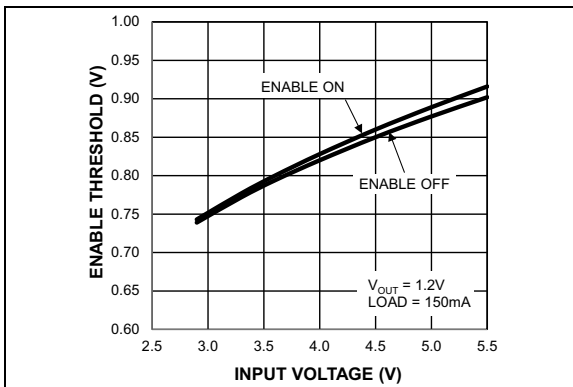
**FIGURE 2-6:** Output Voltage vs. Output Current (HLL).



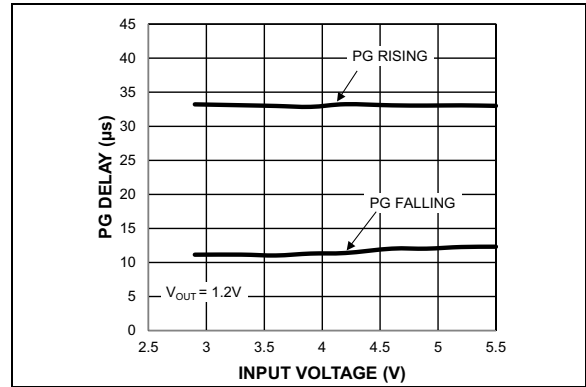
**FIGURE 2-7:** Output Voltage vs Output Current (CCM).



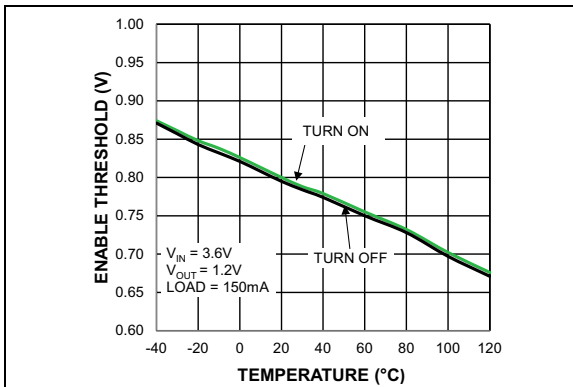
**FIGURE 2-10:** Undervoltage Lockout vs. Temperature.



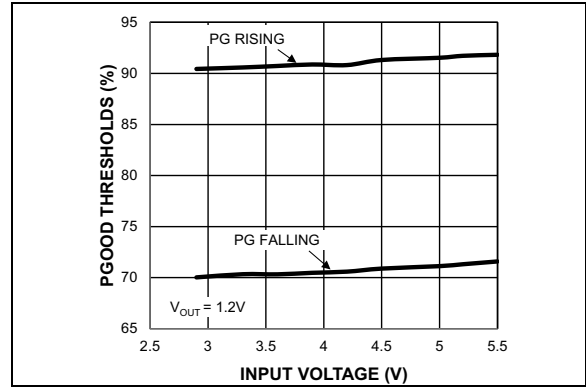
**FIGURE 2-8:** Enable Thresholds vs. Input Voltage.



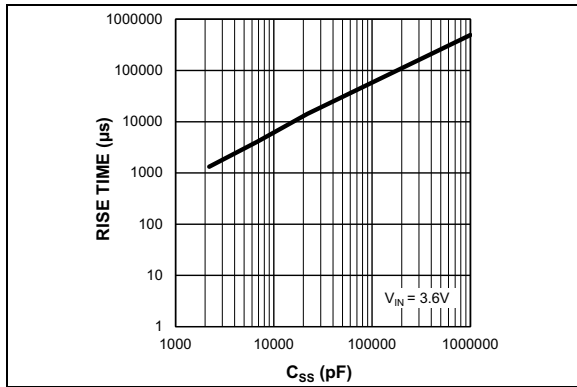
**FIGURE 2-11:** PGOOD Delay Time vs. Input Voltage.



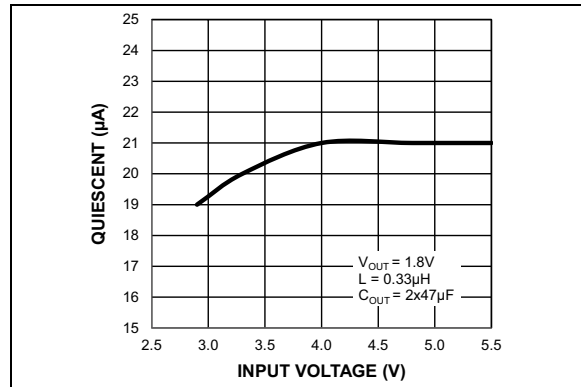
**FIGURE 2-9:** Enable Thresholds vs. Temperature.



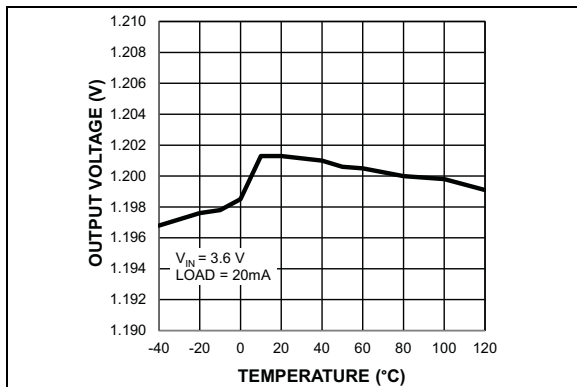
**FIGURE 2-12:** PGOOD Thresholds vs. Input Voltage.



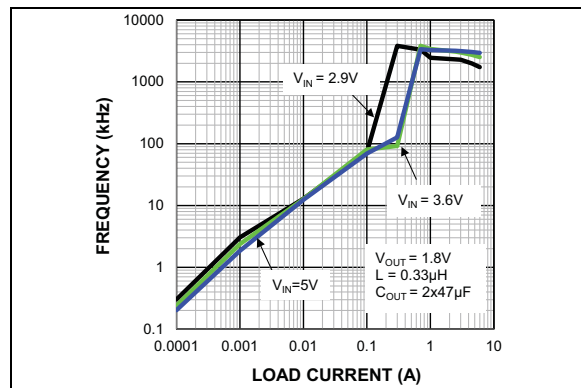
**FIGURE 2-13:**  $V_{OUT}$  Rise Time vs.  $C_{SS}$ .



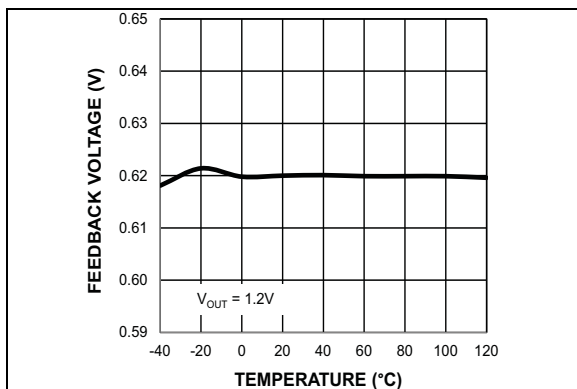
**FIGURE 2-16:** Quiescent Current vs. Input Voltage.



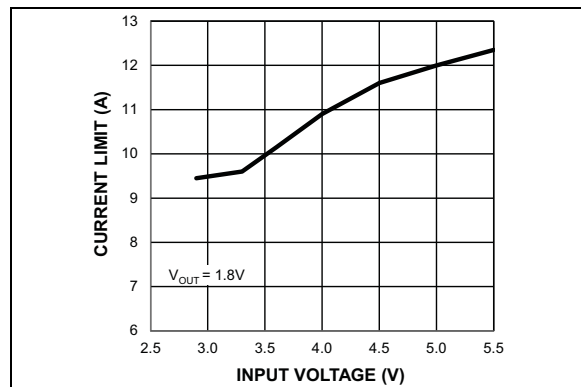
**FIGURE 2-14:** Output Voltage vs. Temperature.



**FIGURE 2-17:** Switching Frequency vs. Load Current.

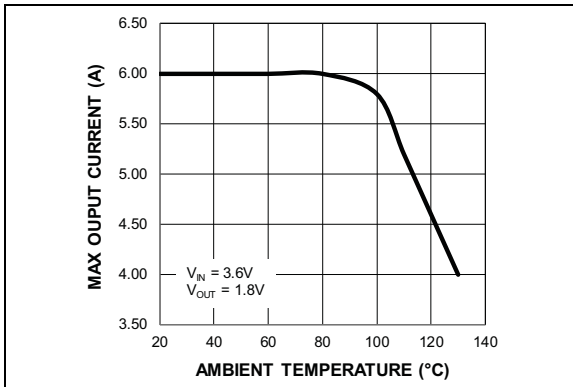


**FIGURE 2-15:** Feedback Voltage vs. Temperature.

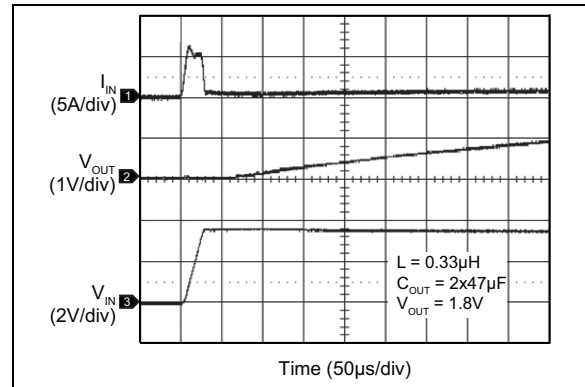


**FIGURE 2-18:** Current Limit vs. Input Voltage.

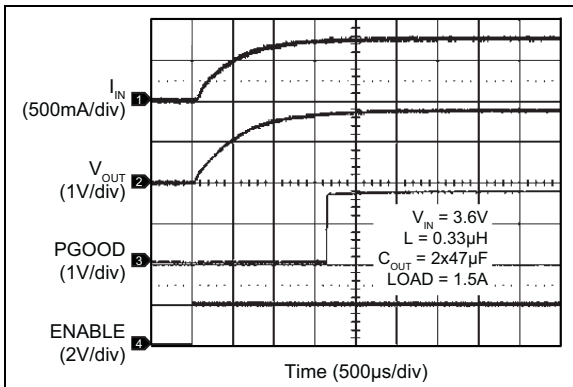




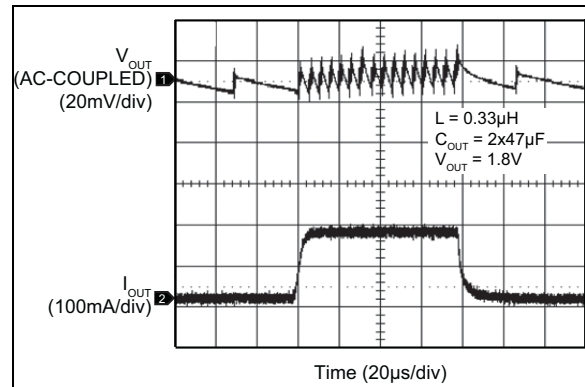
**FIGURE 2-19:** Maximum Output Current vs. Ambient Temperature.



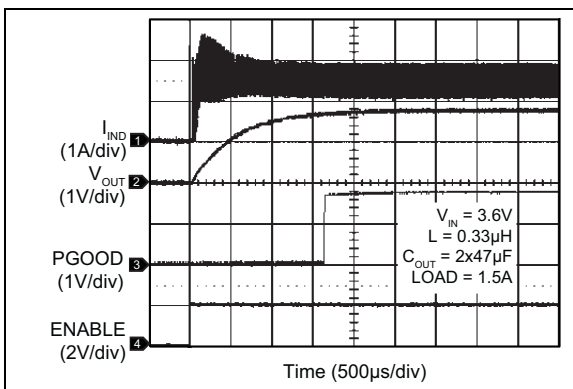
**FIGURE 2-22:** Hot Plug Input Current.



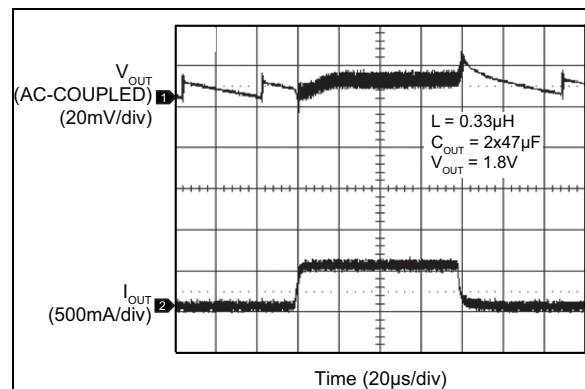
**FIGURE 2-20:** Turn-On Input Current.



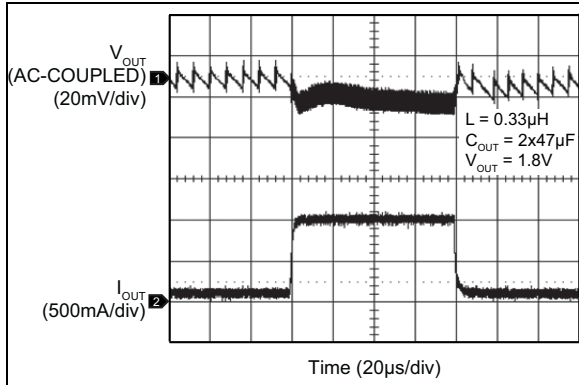
**FIGURE 2-23:** Load Transmit 10 mA to 200 mA.



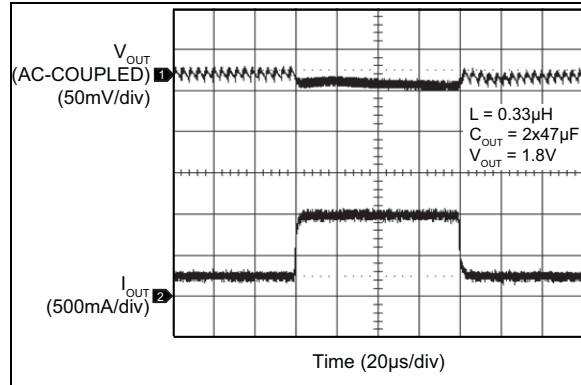
**FIGURE 2-21:** Start-Up Inductor Current.



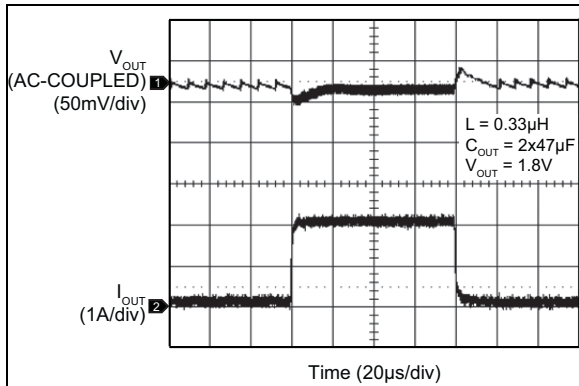
**FIGURE 2-24:** Load Transmit 10 mA to 500 mA.



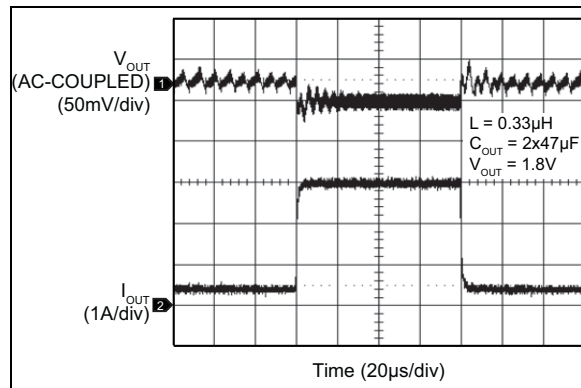
**FIGURE 2-25:** Load Transient 50 mA to 1A.



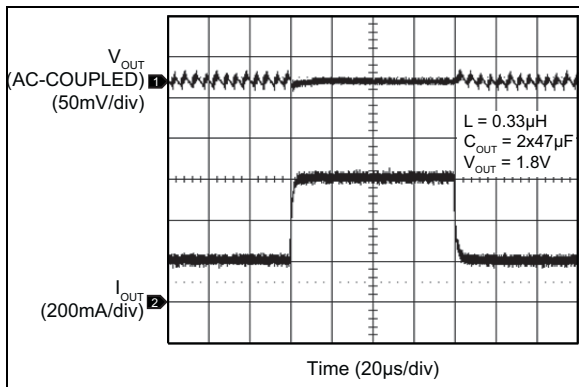
**FIGURE 2-28:** Load Transient 200 mA to 1A.



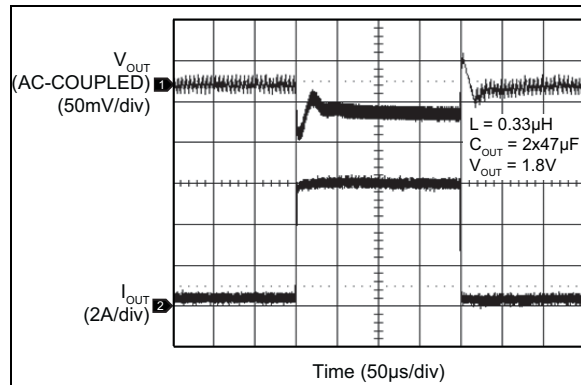
**FIGURE 2-26:** Load Transient 50 mA to 2A.



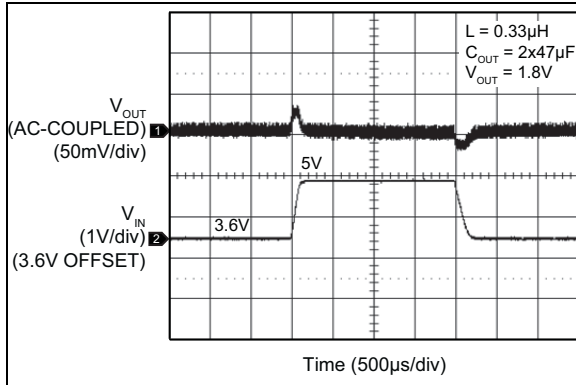
**FIGURE 2-29:** Load Transient 200 mA to 3A.



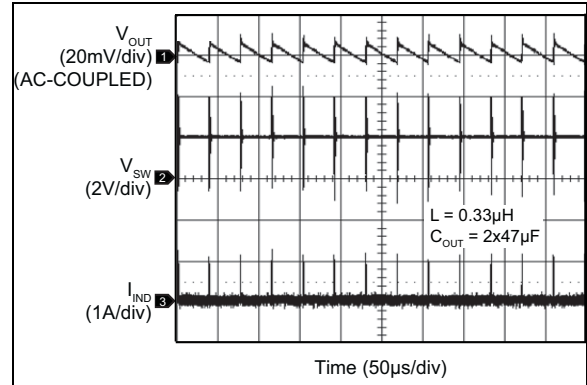
**FIGURE 2-27:** Load Transient 200 mA to 600 mA.



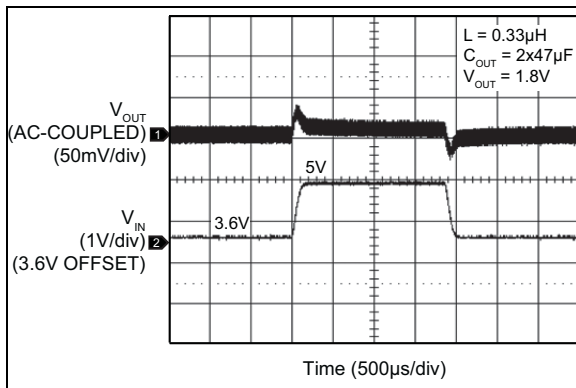
**FIGURE 2-30:** Load Transient 200 mA to 6A.



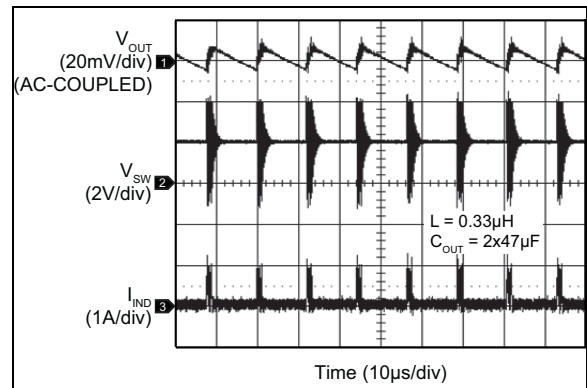
**FIGURE 2-31:** Line Transient 100 mA Load.



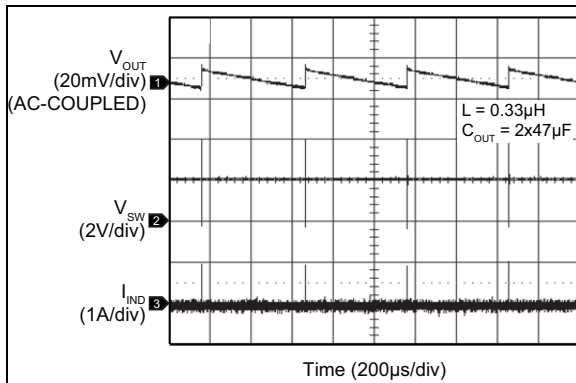
**FIGURE 2-34:** Switching Waveform Discontinuous Mode (10 mA).



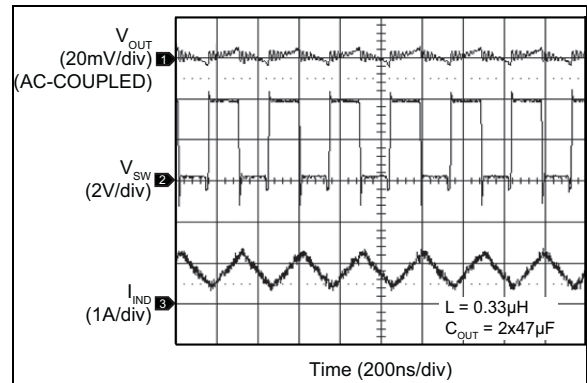
**FIGURE 2-32:** Line Transient 6A Load.



**FIGURE 2-35:** Switching Waveform Discontinuous Mode (50 mA).



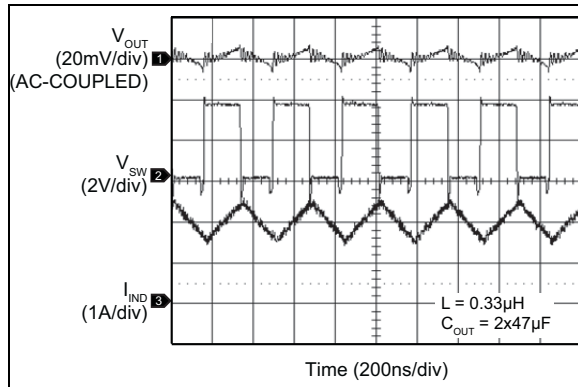
**FIGURE 2-33:** Switching Waveform Discontinuous Mode (1 mA).



**FIGURE 2-36:** Switching Waveform Continuous Mode (800 mA).

# MIC23603

---



**FIGURE 2-37:** *Switching Waveform  
Continuous Mode (2A).*

## 3.0 PIN DESCRIPTIONS

The descriptions of the pins are listed in [Table 3-1](#).

**TABLE 3-1: PIN FUNCTION TABLE**

Pin Number	Pin Name	Description
1, 2, 9, 10, 11, 12, 19, 20	SW	Switch output. Internal power MOSFET output switches.
3, 13, 14, 18	PV <sub>IN</sub>	Input voltage. Connect a capacitor to ground to decouple the noise.
4	PG	Power good. Connect an external resistor to a voltage source to supply a power good indicator.
5	EN	Enable input. Logic high enables operation of the regulator. Logic low shuts down the device. Do not leave floating.
6	SNS	Sense input. Connect to V <sub>OUT</sub> as close to output capacitor as possible to sense output voltage.
7	FB	Feedback input. Connect an external divider between V <sub>OUT</sub> and ground to program the output voltage.
8,16	AGND	Analog ground. Connect to central ground point where all high current paths meet (C <sub>IN</sub> , C <sub>OUT</sub> , P <sub>GND</sub> ) for best operation.
15	SS	Soft Start. Place a capacitor from this pin to ground to program the soft start time. Do not leave floating, 2.2 nF minimum C <sub>SS</sub> is required.
17	AV <sub>IN</sub>	Supply voltage. Analog control circuitry. Connect to V <sub>IN</sub> through a 10Ω resistor.
EP	PGND	Power Ground.

# MIC23603

## 4.0 FUNCTIONAL DESCRIPTION

### 4.1 $PV_{IN}$

The input supply ( $PV_{IN}$ ) provides power to the internal MOSFETs for the switch mode regulator and the driver circuitry. The  $PV_{IN}$  operating range is 2.7V to 5.5V, so an input capacitor, with a minimum voltage rating of 6.3V, is recommended. Because of the high switching speed, a minimum 10  $\mu$ F bypass capacitor placed close to  $V_{IN}$  and the power ground (PGND) pin is required.

### 4.2 $AV_{IN}$

Analog  $V_{IN}$  ( $AV_{IN}$ ) provides power to the internal control and analog circuitry.  $AV_{IN}$  and  $PV_{IN}$  must be tied together through a 10 $\Omega$  resistor to minimize noise coupling from  $PV_{IN}$ . Consider the layout carefully to reduce high frequency switching noise caused by  $V_{IN}$  before reaching  $AV_{IN}$ . Place a 1  $\mu$ F capacitor as close to  $AV_{IN}$  as possible.

### 4.3 EN

A logic high signal on the enable pin activates the device's output voltage. A logic low signal on the enable pin deactivates the output and reduces supply current to 0.01  $\mu$ A. The MIC23603 features built-in soft-start circuitry that reduces inrush current and prevents the output voltage from overshooting at start-up. Do not leave EN floating.

### 4.4 SW

The switch (SW) connects directly to one end of the inductor and provides the current path during switching cycles. The other end of the inductor is connected to the load, SNS pin, and output capacitor. Because of the high speed switching on this pin, route the switch node away from sensitive nodes whenever possible.

### 4.5 SNS

The sense (SNS) pin is connected to the device's output to provide feedback to the control circuitry. Place the SNS connection close to the output capacitor.

### 4.6 PG

The power good (PG) pin is an open-drain output that indicates logic high when the output voltage is typically above 90% of its steady state voltage. A pull-up resistor of more than 5 k $\Omega$  should be connected from PG to  $V_{OUT}$ .

### 4.7 AGND

The analog ground (AGND) is the ground path for the biasing and control circuitry. The current loop for the signal ground should be separate from the power ground (PGND) loop. Placing a 3 $\Omega$  resistor between AGND and PGND reduces ground noise.

### 4.8 PGND

The power ground pin is the ground return path for the inductor current during the freewheeling stage. The current loop for the power ground should be as small as possible and separate from the analog ground (AGND) loop as applicable.

### 4.9 SS

The soft-start (SS) pin is used to control the output voltage ramp up time. The approximate equation for the ramp time in seconds is:

#### EQUATION 4-1:

$$250 \times 10^3 \times L(10) \times C_{SS}$$

For example, for  $C_{SS} = 2.2$  nF,  $T_{RISE} \sim 1.26$  ms. See the [Typical Performance Curves](#) for a graphical guide. The minimum recommended value for  $C_{SS}$  is 2.2 nF.

### 4.10 FB

The feedback (FB) pin is provided for the adjustable voltage option (no internal connection for fixed options). This is the control input for programming the output voltage. A resistor divider network is connected to this pin from the output and is compared to the internal 0.62V reference within the regulation loop.

Use [Equation 4-2](#) to program the output voltage between 0.65V and 3.6V:

#### EQUATION 4-2:

$$V_{OUT} = V_{REF} \times \left(1 + \frac{R3}{R4}\right)$$

Where: R3 is the top resistor, R4 is the bottom resistor.

TABLE 4-1: EXAMPLE FEEDBACK RESISTOR VALUES

$V_{OUT}$	R3	R4
1.2V	274 k $\Omega$	294 k $\Omega$
1.5V	316 k $\Omega$	221 k $\Omega$
1.8V	560 k $\Omega$	294 k $\Omega$
2.5V	324 k $\Omega$	107 k $\Omega$
3.3V	464 k $\Omega$	107 k $\Omega$

## 5.0 APPLICATION INFORMATION

The MIC23603 is a high-performance DC/DC step-down regulator offering a small solution size. Because it supports an output current up to 6A inside a tiny 4 mm x 5 mm DFN package and requires only three external components, the MIC23603 meets today's miniature portable electronic device needs. Using the HyperLight Load switching scheme, the MIC23603 maintains high efficiency throughout the entire load range while providing ultra-fast load transient response. The following sections provide additional device application information.

### 5.1 Input Capacitor

Place a 10  $\mu\text{F}$  ceramic capacitor or greater close to the  $V_{\text{IN}}$  pin and PGND/GND pin for bypassing. The TDK C1608X5R0J106K, size 0603, 10  $\mu\text{F}$  ceramic capacitor is recommended based upon performance, size, and cost. An X5R or X7R temperature rating is recommended for the input capacitor. Y5V temperature rating capacitors, aside from losing most of their capacitance over temperature, can also become resistive at high frequencies. This reduces their ability to filter out high frequency noise.

### 5.2 Output Capacitor

The MIC23603 was designed for use with a 47  $\mu\text{F}$  or greater ceramic output capacitor. Increasing the output capacitance lowers output ripple and improves load transient response, but could increase solution size or cost. A low equivalent series resistance (ESR) ceramic output capacitor such as the TDK C3216X6S1A476M, size 1206, 47  $\mu\text{F}$  ceramic capacitor is recommended based upon performance, size and cost. Both the X7R or X5R temperature rating capacitors are recommended. The Y5V and Z5U temperature rating capacitors are not recommended because of their wide variation in capacitance over temperature and increased resistance at high frequencies.

### 5.3 Inductor Selection

When selecting an inductor, consider the following factors (not necessarily in order of importance):

- Inductance
- Rated current value
- Size requirements
- DC resistance (DCR)

The MIC23603 was designed for use with a 0.33  $\mu\text{H}$  to 1  $\mu\text{H}$  inductor. For faster transient response, a 0.33  $\mu\text{H}$  inductor yields the best result. For lower output ripple, a 1  $\mu\text{H}$  inductor is recommended.

Maximum current ratings of the inductor are generally given in two methods: permissible DC current and saturation current. Permissible DC current can be rated

either for a 40°C temperature rise or a 10% to 20% loss in inductance. Make sure that the inductor selected can handle the maximum operating current.

When saturation current is specified, make sure that there is enough margin so that the peak current does not cause the inductor to saturate. Peak current can be calculated using [Equation 5-1](#).

#### EQUATION 5-1:

$$I_{PEAK} = \left[ I_{OUT} + V_{OUT} \left( \frac{1 - V_{OUT}/V_{IN}}{2 \times f \times L} \right) \right]$$

As [Equation 5-1](#) shows, the peak inductor current is inversely proportional to the switching frequency and the inductance; the lower the switching frequency or the inductance, the higher the peak current. As input voltage increases, the peak current also increases.

The size of the inductor depends on the requirements of the application.

DC resistance (DCR) is also important. While DCR is inversely proportional to size, it can represent a significant efficiency loss. See [Efficiency Considerations](#) for information.

### 5.4 Compensation

The MIC23603 is designed to be stable with a 0.33  $\mu\text{H}$  to 1  $\mu\text{H}$  inductor with a minimum of 47  $\mu\text{F}$  ceramic (X5R) output capacitor. A feed-forward capacitor ( $C_{FF}$ ) in the range of 33 pF to 68 pF is recommended across the top feedback resistor to reduce the effects of parasitic capacitance and improve transient performance.

### 5.5 Duty Cycle

The typical maximum duty cycle of the MIC23603 is 80%.

### 5.6 Efficiency Considerations

Efficiency is defined as the amount of useful output power, divided by the amount of power supplied.

#### EQUATION 5-2:

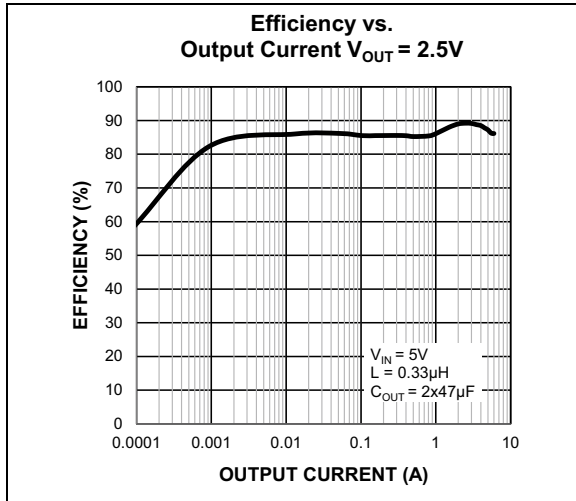
$$Efficiency = \left( \frac{V_{OUT} \times I_{OUT}}{V_{IN} \times I_{IN}} \right) \times 100$$

Maintaining high efficiency serves two purposes. It reduces power dissipation in the power supply, reducing the need for heat sinks and thermal design considerations, and it reduces current consumption for battery powered applications. Reduced current draw from a battery increases the device's operating time and is critical in hand-held devices.



# MIC23603

There are two types of losses in switching converters: DC losses and switching losses. DC losses are simply the power dissipation of  $I^2R$ . Power is dissipated in the high side switch during the on cycle. Power loss is equal to the high side MOSFET  $R_{DS(ON)}$  multiplied by the switch current squared. During the off cycle, the low side N channel MOSFET conducts, also dissipating power. Device operating current also reduces efficiency. The product of the quiescent (operating) current and the supply voltage represents another DC loss. The current needed to drive the gates on and off at a constant 4 MHz frequency and the switching transitions make up the switching losses.



**FIGURE 5-1:** Efficiency Under Load.

Figure 5-1 shows an efficiency curve, from no load to 300 mA. Efficiency losses are dominated by quiescent current losses, gate drive, and transition losses. By using the HyperLight Load mode, the MIC23603 can maintain high efficiency at low output currents.

Over 300 mA, efficiency loss is dominated by MOSFET  $R_{DS(ON)}$  and inductor losses. Higher input supply voltages will increase the gate-to-source drive voltage on the internal MOSFETs, which reduces the internal  $R_{DS(ON)}$ . This improves efficiency by reducing DC losses in the device. All but the inductor losses are inherent to the device. In this case, inductor selection becomes increasingly critical in efficiency calculations. As the inductors get smaller, the DC resistance (DCR) can become quite significant. The DCR losses can be calculated in Equation 5-3.

### EQUATION 5-3:

$$P_{DCR} = I_{OUT}^2 \times DCR$$

From that, the loss in efficiency due to inductor resistance can be calculated Equation 5-5.

### EQUATION 5-4:

$$Efficiency\ Loss = \left[ 1 - \left( \frac{V_{OUT} \times I_{OUT}}{V_{OUT} \times I_{OUT} + P_{DCR}} \right) \right] \times 100$$

Efficiency loss caused by DCR is minimal at light loads and gains significance as the load is increased. Inductor selection becomes a trade-off between efficiency and size.

## 5.7 HyperLight Load Mode

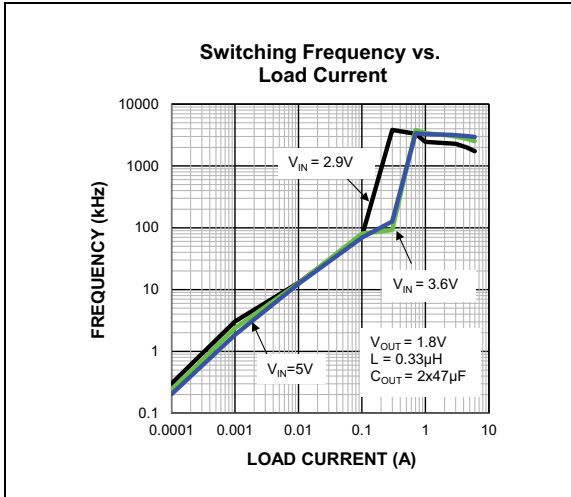
MIC23603 uses a minimum on and off time proprietary control loop. When the output voltage falls below the regulation threshold, the error comparator begins a switching cycle that turns the PMOS on and keeps it on for the duration of the minimum-on-time. This increases the output voltage. If the output voltage is over the regulation threshold, then the error comparator turns the PMOS off for a minimum-off-time until the output drops below the threshold. The NMOS acts as an ideal rectifier that conducts when the PMOS is off. Using an NMOS switch instead of a diode allows for lower voltage drop across the switching device when it is on. The asynchronous switching combination between the PMOS and the NMOS allows the control loop to work in discontinuous mode for light load operations. In discontinuous mode, the MIC23603 works in pulse frequency modulation (PFM) to regulate the output. As the output current increases, the off-time decreases, which provides more energy to the output. This switching scheme improves the efficiency of MIC23603 during light load currents by switching only when needed. As the load current increases, the MIC23603 goes into continuous conduction mode (CCM) and switches at a frequency centered at 4 MHz. The load when the MIC23603 goes into continuous conduction mode may be approximated by the formula in Equation 5-5.

### EQUATION 5-5:

$$I_{LOAD} > \left( \frac{(V_{IN} - V_{OUT}) \times D}{2L \times f} \right)$$

As shown in the previous equation, the load at which MIC23603 transitions from HyperLight Load mode to PWM mode is a function of the input voltage ( $V_{IN}$ ), output voltage ( $V_{OUT}$ ), duty cycle (D), inductance (L), and frequency (f). As shown in Figure 5-2, as the Output Current increases, the switching frequency also increases, until the MIC23603 goes from HyperLight Load mode to PWM mode at approximately 300 mA. The MIC23603 switches a relatively constant frequency around 4 MHz after the output current is over 300 mA.





**FIGURE 5-2:** SW Frequency vs. Load Current.

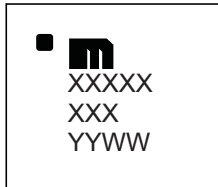
# MIC23603

---

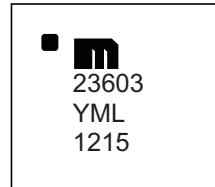
## 6.0 PACKAGING INFORMATION

### 6.1 Package Marking Information

20-lead DFN\*



Example



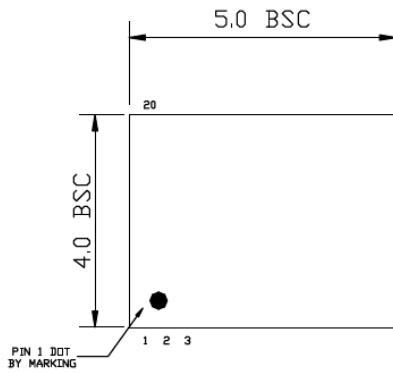
<b>Legend:</b>	XX...X	Product code or customer-specific information
	Y	Year code (last digit of calendar year)
	YY	Year code (last 2 digits of calendar year)
	WW	Week code (week of January 1 is week '01')
	NNN	Alphanumeric traceability code
	(e3)	Pb-free JEDEC® designator for Matte Tin (Sn)
	*	This package is Pb-free. The Pb-free JEDEC designator (e3) can be found on the outer packaging for this package.
	•, ▲, ▼	Pin one index is identified by a dot, delta up, or delta down (triangle mark).
<b>Note:</b>	In the event the full Microchip part number cannot be marked on one line, it will be carried over to the next line, thus limiting the number of available characters for customer-specific information. Package may or may not include the corporate logo.	
	Underbar ( _ ) symbol may not be to scale.	

## 20-Lead 4.0 mm x 5.0 mm DFN Package Outline and Recommended Land Pattern

**TITLE**

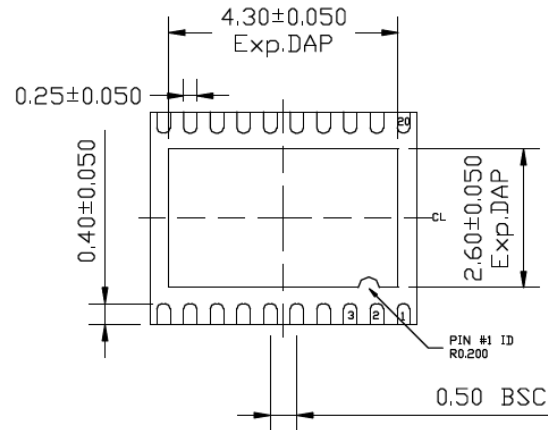
20 LEAD DFN 4.0 x 5.0 mm PACKAGE OUTLINE & RECOMMENDED LAND PATTERN

DRAWING #	DFN45-20LD-PL-1	UNIT	MM
-----------	-----------------	------	----



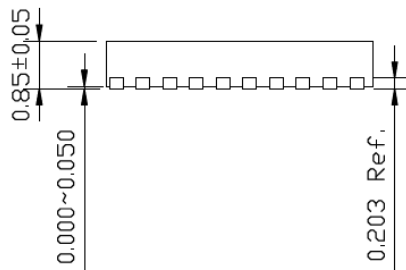
TOP VIEW

NOTE: 1, 2, 3



BOTTOM VIEW

NOTE: 1, 2



SIDE VIEW

NOTE: 1, 2

**NOTE:**

1. MAX PACKAGE WARPAGE IS 0.05MM
2. MAX ALLOWABLE BURR IS 0.076MM IN ALL DIRECTIONS
3. PIN #1 IS ON TOP WILL BE LASER MARKED
4. GREEN RECTANGLES (SHADED AREA) REPRESENT STENCIL OPENING ON EXPOSED AREA. SIZE IS 1.17X0.60 MM, 0.80 MM SPACING
5. RED CIRCLES REPRESENT THERMAL VIAS & SHOULD BE CONNECTED TO GND FOR MAX PERFORMANCE. 0.30 - 0.35 MM RECOMMENDED DIAMETER

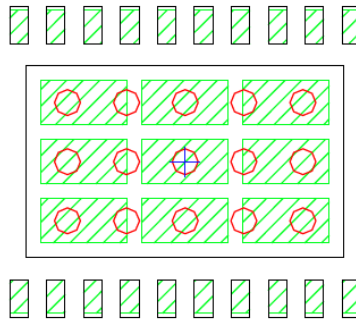
Note: For the most current package drawings, please see the Microchip Packaging Specification located at <http://www.microchip.com/packaging>.

# MIC23603

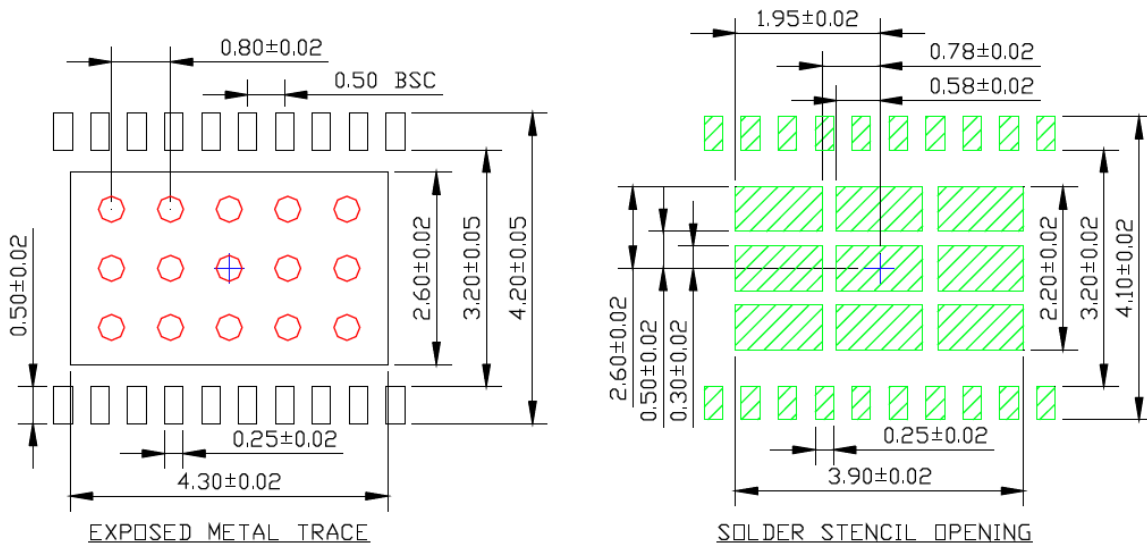
POD-Land Pattern drawing #DFN45-20LD-PL-1

## RECOMMENDED LAND PATTERN

NOTE: 4, 5



STACKED-UP



Note: For the most current package drawings, please see the Microchip Packaging Specification located at <http://www.microchip.com/packaging>.

## APPENDIX A: REVISION HISTORY

### Revision A (July 2017)

- Converted Micrel document MIC23603 to Microchip data sheet template DS2005636A.
- Minor text changes throughout.

# MIC23603

---

NOTES:

## PRODUCT IDENTIFICATION SYSTEM

To order or obtain information, e.g., on pricing or delivery, contact your local Microchip representative or sales office.

<u>PART NO.</u>		X	XX
Device		Junction Temperature Range	Package
<b>Device:</b>	MIC23603:	4 MHz PWM 6A Buck Regulator with HyperLight Load®	
<b>Junction Temperature Range:</b>	Y	=	-40°C to +85°C (Pb-Free)
<b>Packages:</b>	ML	=	20-lead 4 mm x 5 mm DFN

**Examples:**

a) MIC23603YML:      4 MHz PWM 6A Buck Regulator with HyperLight Load®, -40°C to +85°C (Pb-Free), 20-lead 4 mm x 5 mm DFN

**Note 1:** 1.DFN is GREEN RoHS-compliant package. Lead finish is NiPdAu. Mold compound is Halogen Free.

# MIC23603

---

NOTES:



---

---

**Note the following details of the code protection feature on Microchip devices:**

- Microchip products meet the specification contained in their particular Microchip Data Sheet.
- Microchip believes that its family of products is one of the most secure families of its kind on the market today, when used in the intended manner and under normal conditions.
- There are dishonest and possibly illegal methods used to breach the code protection feature. All of these methods, to our knowledge, require using the Microchip products in a manner outside the operating specifications contained in Microchip's Data Sheets. Most likely, the person doing so is engaged in theft of intellectual property.
- Microchip is willing to work with the customer who is concerned about the integrity of their code.
- Neither Microchip nor any other semiconductor manufacturer can guarantee the security of their code. Code protection does not mean that we are guaranteeing the product as “unbreakable.”

Code protection is constantly evolving. We at Microchip are committed to continuously improving the code protection features of our products. Attempts to break Microchip's code protection feature may be a violation of the Digital Millennium Copyright Act. If such acts allow unauthorized access to your software or other copyrighted work, you may have a right to sue for relief under that Act.

---

Information contained in this publication regarding device applications and the like is provided only for your convenience and may be superseded by updates. It is your responsibility to ensure that your application meets with your specifications. MICROCHIP MAKES NO REPRESENTATIONS OR WARRANTIES OF ANY KIND WHETHER EXPRESS OR IMPLIED, WRITTEN OR ORAL, STATUTORY OR OTHERWISE, RELATED TO THE INFORMATION, INCLUDING BUT NOT LIMITED TO ITS CONDITION, QUALITY, PERFORMANCE, MERCHANTABILITY OR FITNESS FOR PURPOSE. Microchip disclaims all liability arising from this information and its use. Use of Microchip devices in life support and/or safety applications is entirely at the buyer's risk, and the buyer agrees to defend, indemnify and hold harmless Microchip from any and all damages, claims, suits, or expenses resulting from such use. No licenses are conveyed, implicitly or otherwise, under any Microchip intellectual property rights unless otherwise stated.

*Microchip received ISO/TS-16949:2009 certification for its worldwide headquarters, design and wafer fabrication facilities in Chandler and Tempe, Arizona; Gresham, Oregon and design centers in California and India. The Company's quality system processes and procedures are for its PIC® MCUs and dsPIC® DSCs, KEELoC® code hopping devices, Serial EEPROMs, microperipherals, nonvolatile memory and analog products. In addition, Microchip's quality system for the design and manufacture of development systems is ISO 9001:2000 certified.*

**QUALITY MANAGEMENT SYSTEM  
CERTIFIED BY DNV  
= ISO/TS 16949 =**

### Trademarks

The Microchip name and logo, the Microchip logo, AnyRate, AVR, AVR logo, AVR Freaks, BeaconThings, BitCloud, CryptoMemory, CryptoRF, dsPIC, FlashFlex, flexPWR, Helder, JukeBlox, KEELoC, KEELoC logo, Klear, LANCheck, LINK MD, maXStylus, maXTouch, MediaLB, megaAVR, MOST, MOST logo, MPLAB, OptoLyzer, PIC, picoPower, PICSTART, PIC32 logo, Prochip Designer, QTouch, RightTouch, SAM-BA, SpyNIC, SST, SST Logo, SuperFlash, tinyAVR, UNI/O, and XMEGA are registered trademarks of Microchip Technology Incorporated in the U.S.A. and other countries.

ClockWorks, The Embedded Control Solutions Company, EtherSynch, Hyper Speed Control, HyperLight Load, IntelliMOS, mTouch, Precision Edge, and Quiet-Wire are registered trademarks of Microchip Technology Incorporated in the U.S.A.

Adjacent Key Suppression, AKS, Analog-for-the-Digital Age, Any Capacitor, AnyIn, AnyOut, BodyCom, chipKIT, chipKIT logo, CodeGuard, CryptoAuthentication, CryptoCompanion, CryptoController, dsPICDEM, dsPICDEM.net, Dynamic Average Matching, DAM, ECAN, EtherGREEN, In-Circuit Serial Programming, ICSP, Inter-Chip Connectivity, JitterBlocker, KlearNet, KlearNet logo, Mindi, MiWi, motorBench, MPASM, MPF, MPLAB Certified logo, MPLIB, MPLINK, MultiTRAK, NetDetach, Omniscient Code Generation, PICDEM, PICDEM.net, PICKit, PICTail, PureSilicon, QMatrix, RightTouch logo, REAL ICE, Ripple Blocker, SAM-ICE, Serial Quad I/O, SMART-I.S., SQI, SuperSwitcher, SuperSwitcher II, Total Endurance, TSHARC, USBCheck, VariSense, ViewSpan, WiperLock, Wireless DNA, and ZENA are trademarks of Microchip Technology Incorporated in the U.S.A. and other countries.

SQTP is a service mark of Microchip Technology Incorporated in the U.S.A.

Silicon Storage Technology is a registered trademark of Microchip Technology Inc. in other countries.

GestIC is a registered trademark of Microchip Technology Germany II GmbH & Co. KG, a subsidiary of Microchip Technology Inc., in other countries.

All other trademarks mentioned herein are property of their respective companies.

© 2017, Microchip Technology Incorporated, All Rights Reserved.  
ISBN: 978-1-5224-1961-7



# MICROCHIP

## Worldwide Sales and Service

### AMERICAS

**Corporate Office**  
2355 West Chandler Blvd.  
Chandler, AZ 85224-6199  
Tel: 480-792-7200  
Fax: 480-792-7277  
Technical Support:  
<http://www.microchip.com/support>  
Web Address:  
[www.microchip.com](http://www.microchip.com)

**Atlanta**  
Duluth, GA  
Tel: 678-957-9614  
Fax: 678-957-1455

**Austin, TX**  
Tel: 512-257-3370

**Boston**  
Westborough, MA  
Tel: 774-760-0087  
Fax: 774-760-0088

**Chicago**  
Itasca, IL  
Tel: 630-285-0071  
Fax: 630-285-0075

**Dallas**  
Addison, TX  
Tel: 972-818-7423  
Fax: 972-818-2924

**Detroit**  
Novi, MI  
Tel: 248-848-4000

**Houston, TX**  
Tel: 281-894-5983

**Indianapolis**  
Noblesville, IN  
Tel: 317-773-8323  
Fax: 317-773-5453  
Tel: 317-536-2380

**Los Angeles**  
Mission Viejo, CA  
Tel: 949-462-9523  
Fax: 949-462-9608  
Tel: 951-273-7800

**Raleigh, NC**  
Tel: 919-844-7510

**New York, NY**  
Tel: 631-435-6000

**San Jose, CA**  
Tel: 408-735-9110  
Tel: 408-436-4270

**Canada - Toronto**  
Tel: 905-695-1980  
Fax: 905-695-2078

### ASIA/PACIFIC

**Asia Pacific Office**  
Suites 3707-14, 37th Floor  
Tower 6, The Gateway  
Harbour City, Kowloon

**Hong Kong**  
Tel: 852-2943-5100  
Fax: 852-2401-3431

**Australia - Sydney**  
Tel: 61-2-9868-6733  
Fax: 61-2-9868-6755

**China - Beijing**  
Tel: 86-10-8569-7000  
Fax: 86-10-8528-2104

**China - Chengdu**  
Tel: 86-28-8665-5511  
Fax: 86-28-8665-7889

**China - Chongqing**  
Tel: 86-23-8980-9588  
Fax: 86-23-8980-9500

**China - Dongguan**  
Tel: 86-769-8702-9880

**China - Guangzhou**  
Tel: 86-20-8755-8029

**China - Hangzhou**  
Tel: 86-571-8792-8115  
Fax: 86-571-8792-8116

**China - Hong Kong SAR**  
Tel: 852-2943-5100  
Fax: 852-2401-3431

**China - Nanjing**  
Tel: 86-25-8473-2460  
Fax: 86-25-8473-2470

**China - Qingdao**  
Tel: 86-532-8502-7355  
Fax: 86-532-8502-7205

**China - Shanghai**  
Tel: 86-21-3326-8000  
Fax: 86-21-3326-8021

**China - Shenyang**  
Tel: 86-24-2334-2829  
Fax: 86-24-2334-2393

**China - Shenzhen**  
Tel: 86-755-8864-2200  
Fax: 86-755-8203-1760

**China - Wuhan**  
Tel: 86-27-5980-5300  
Fax: 86-27-5980-5118

**China - Xian**  
Tel: 86-29-8833-7252  
Fax: 86-29-8833-7256

### ASIA/PACIFIC

**China - Xiamen**  
Tel: 86-592-2388138  
Fax: 86-592-2388130

**China - Zhuhai**  
Tel: 86-756-3210040  
Fax: 86-756-3210049

**India - Bangalore**  
Tel: 91-80-3090-4444  
Fax: 91-80-3090-4123

**India - New Delhi**  
Tel: 91-11-4160-8631  
Fax: 91-11-4160-8632

**India - Pune**  
Tel: 91-20-3019-1500

**Japan - Osaka**  
Tel: 81-6-6152-7160  
Fax: 81-6-6152-9310

**Japan - Tokyo**  
Tel: 81-3-6880-3770  
Fax: 81-3-6880-3771

**Korea - Daegu**  
Tel: 82-53-744-4301  
Fax: 82-53-744-4302

**Korea - Seoul**  
Tel: 82-2-554-7200  
Fax: 82-2-558-5932 or  
82-2-558-5934

**Malaysia - Kuala Lumpur**  
Tel: 60-3-6201-9857  
Fax: 60-3-6201-9859

**Malaysia - Penang**  
Tel: 60-4-227-8870  
Fax: 60-4-227-4068

**Philippines - Manila**  
Tel: 63-2-634-9065  
Fax: 63-2-634-9069

**Singapore**  
Tel: 65-6334-8870  
Fax: 65-6334-8850

**Taiwan - Hsin Chu**  
Tel: 886-3-5778-366  
Fax: 886-3-5770-955

**Taiwan - Kaohsiung**  
Tel: 886-7-213-7830

**Taiwan - Taipei**  
Tel: 886-2-2508-8600  
Fax: 886-2-2508-0102

**Thailand - Bangkok**  
Tel: 66-2-694-1351  
Fax: 66-2-694-1350

### EUROPE

**Austria - Wels**  
Tel: 43-7242-2244-39  
Fax: 43-7242-2244-393

**Denmark - Copenhagen**  
Tel: 45-4450-2828  
Fax: 45-4485-2829

**Finland - Espoo**  
Tel: 358-9-4520-820

**France - Paris**  
Tel: 33-1-69-53-63-20  
Fax: 33-1-69-30-90-79

**France - Saint Cloud**  
Tel: 33-1-30-60-70-00

**Germany - Garching**  
Tel: 49-8931-9700

**Germany - Haan**  
Tel: 49-2129-3766400

**Germany - Heilbronn**  
Tel: 49-7131-67-3636

**Germany - Karlsruhe**  
Tel: 49-721-625370

**Germany - Munich**  
Tel: 49-89-627-144-0  
Fax: 49-89-627-144-44

**Germany - Rosenheim**  
Tel: 49-8031-354-560

**Israel - Ra'anana**  
Tel: 972-9-744-7705

**Italy - Milan**  
Tel: 39-0331-742611  
Fax: 39-0331-466781

**Italy - Padova**  
Tel: 39-049-7625286

**Netherlands - Drunen**  
Tel: 31-416-690399  
Fax: 31-416-690340

**Norway - Trondheim**  
Tel: 47-7289-7561

**Poland - Warsaw**  
Tel: 48-22-3325737

**Romania - Bucharest**  
Tel: 40-21-407-87-50

**Spain - Madrid**  
Tel: 34-91-708-08-90  
Fax: 34-91-708-08-91

**Sweden - Gothenberg**  
Tel: 46-31-704-60-40

**Sweden - Stockholm**  
Tel: 46-8-5090-4654

**UK - Wokingham**  
Tel: 44-118-921-5800  
Fax: 44-118-921-5820

## X-ON Electronics

Largest Supplier of Electrical and Electronic Components

*Click to view similar products for [Switching Voltage Regulators](#) category:*

*Click to view products by [Micrel](#) manufacturer:*

Other Similar products are found below :

[FAN53610AUC33X](#) [FAN53611AUC123X](#) [FAN48610BUC33X](#) [FAN48610BUC45X](#) [FAN48617UC50X](#) [R3](#) [430464BB](#) [MIC45116-1YMP-T1](#) [KE177614](#) [MAX809TTR](#) [NCV891234MW50R2G](#) [NCP81103MNTXG](#) [NCP81203PMNTXG](#) [NCP81208MNTXG](#) [NCP81109GMNTXG](#) [SCY1751FCCT1G](#) [NCP81109JMNTXG](#) [AP3409ADNTR-G1](#) [LTM8064IY](#) [LT8315EFE#TRPBF](#) [NCV1077CSTBT3G](#) [XCL207A123CR-G](#) [MPM54304GMN-0002](#) [MPM54304GMN-0003](#) [XDPE132G5CG000XUMA1](#) [DA9121-B0V76](#) [LTC3644IY#PBF](#) [MP8757GL-P](#) [MIC23356YFT-TR](#) [LD8116CGL](#) [HG2269M/TR](#) [OB2269](#) [XD3526](#) [U6215A](#) [U6215B](#) [U6620S](#) [LTC3803ES6#TR](#) [LTC3803ES6#TRM](#) [LTC3412IFE](#) [LT1425IS](#) [MAX25203BATJA/VY+](#) [MAX77874CEWM+](#) [XC9236D08CER-G](#) [ISL95338IRTZ](#) [MP3416GJ-P](#) [BD9S201NUX-CE2](#) [MP5461GC-Z](#) [MPQ4415AGQB-Z](#) [MPQ4590GS-Z](#) [MCP1603-330IMC](#)