



MIC3232 Evaluation Board

High Voltage Boost HBLED Driver with PWM Dimming Control

Bringing the Power to Light™

General Description

The MIC3232 is a constant current boost switching controller specifically designed to power one or more strings of high power LEDs. The MIC3232 has an input voltage range from 6V to 45V and is ideal for a variety of applications. The MIC3232 is the fixed 400kHz version of the MIC3230, in a 10-pin MSOP package.

The MIC3232 utilizes an external power device which offers a cost conscious solution for driving high power LED applications. Power consumption has been minimized through the implementation of a 250mV feedback voltage reference providing an accuracy of $\pm 3\%$. The MIC3232 is dimmable via a PWM input signal and also features an enable pin for low power shutdown.

The LED current is regulated by keeping the voltage drop across the current sense resistor (R7) constant. The LED current can be set by selecting the value of R7. In this version of the eval board, the output current is limited to 1A.

Table 1 provides a summary of the eval board specifications. The evaluation board schematic is shown in Figure 1 and the parts list is shown in the Bill of Materials table.

Requirements

1. Voltage source capable of supplying 50 Watts
2. Load: LED, resistive or electronic load
3. Scope
4. Voltage meter
5. (Optional) Function generator for PWM Dimming

Precautions

The evaluation board does not have input reverse polarity protection. Applying a negative voltage at the VIN terminal may damage the board. When the controller is off there is a current path through the inductor and the flyback diode to the output. No current limit exists for this current path so care must be taken not to short circuit the output.

How it works

The MIC3232 evaluation board is set to operate as a boost converter, which requires the output voltage to be greater than the input voltage. It is important to have the series LED forward voltage drops be greater than the input voltage because when the MIC3232 is off, the input is connected to the output through the inductor (L1) and diode (D1). The input voltage (V_{IN}) is effectively applied across the LEDs and will turn on if V_{IN} is greater than the sum of the forward voltage drops across the LED string. For 100% duty cycle, simply pull PWMD high or leave open. For a different LED current change R7 using the following equation. When R7 is 0.62Ω the LED current is to 0.4A. The evaluation board is currently set to this output current value.

$$I_{LED} = \frac{V_{REF}}{R7} \quad \text{Where } V_{REF} = 0.25$$

PWM Dimming

A PWM signal applied to the PWMD pin turns the current to the LEDs on and off. When PWMD is high, the MIC3232 is enabled and the boost converter regulates the LED current by keeping the voltage drop across the R7 resistor constant. When PWMD is low the converter turns off and the LED current discharges the output capacitors and the LED current stops.

Ordering Information

Part Number	Description
MIC3232YMM EV	Evaluation board for the MIC3232YML IC

Quick-Start Guide

1. Connect a load (LED series string or resistive load) between V_{OUT} and LED RTN (this is not the same as ground).
2. Connect 12V (or other input voltage) to V_{IN} and GND.
3. Use a current probe to measure the load current. and Monitor the Switch node with a scope to view the switch waveform
4. PWM Dimming:
 - a. For no PWM dimming, leave the PWMD terminal open
 - b. For PWM DIMMING connect a function generator to the PWM DIM input and GND (not RTN). Set the output at 0-5V square wave pulse at 300Hz. Make sure the pulse goes all the way to 0V.

R_{SET} – Current Limit Sensing

The MIC3232 features current limit sensing. Current limit is set through the external resistor, R6, by the following equation:

$$I_S = 0.5V = R6 \times I_{Q1}$$

Where, I_{Q1} is the peak FET current that will trigger the current limit, the Default setting for the evaluation board is R6 = 75mΩ with the current limit set at 6.7A.

OVP – Setting the over voltage protection

OVP is set with the R9 resistor, according to equation:

$$OVP = 1.245V = \frac{(R9 \times V_{O,MAX})}{(R8 + R9)}$$

On the evaluation board, these values have been set to: R9=2kΩ and R8=100kΩ and V_{O,MAX} = 64V.

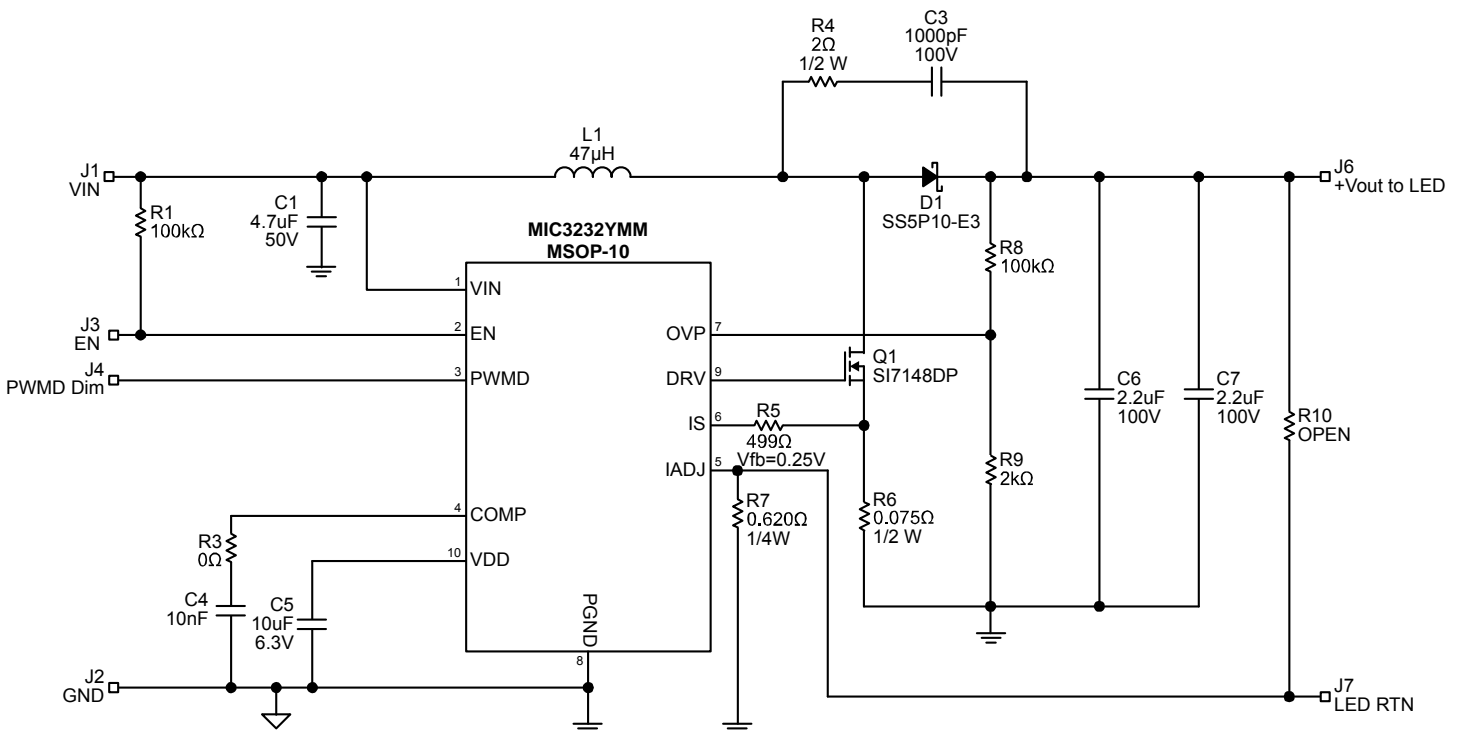

Figure 1. Schematic Diagram

Evaluation Board Design Specifications

	MIN	TYP	MAX
V _{IN}	6V	12-24	45V
Output Voltage	V _{in}	12-24 Series LEDs	90V*
LED Current	0	0.2-.5	0.70A
Power Out	0	20W	70W
Efficiency		90%	
Switching Frequency	100kHz	400kHz	1MHz
PWM Dim Frequency	0	300Hz	500Hz
Line Regulation			<3%
Load Regulation			<3%
Ambient Temperature	-40°C	+25°C	+85°C

*Evaluation Board parts are rated to 75V

Table 1. Evaluation Board Design Specifications

LED current selection

R7 (ohms)	I_LED
5	50mA
2	125mA
1	250mA
0.62	404mA
0.5	500mA
0.4	625mA
.35	0.7A

Table 2. LED current selection

Bill of Materials

Item	Part number	Manufacturer	Part Description	Quant
U1	MIC3232-YMM	Micrel.Inc	Constant Current Boost control for Hi Power LED	1
Q1	SI7148DP-T1	Vishay Siliconix.	N Channel 75V MOSFET	1
D1	SS5P10-E3	Vishay corp	5A, 100V schottky diode	1
L1	MSD1278-473ML	Coilcraft	47 μ H, rate 5.2A inductor	1
C1	GRM32ER71H475KA88L	Murata	4.7 μ F/50V, 1210, Ceramic capacitor	1
C5	GRM21BR61A106KE19L	Murata	10uF/10V, 0805, ceramic capacitor	1
	LMK212BJ106KD-T	Taiyo Yuden		OR
	C0805C106K8PACTU	Kemet		OR
C3 OR	VJ0805Y102KXBAT.	Vishay Vitramon	1nF/100V,0805, Ceramic capacitor	1
	GRM2195C2A102JA01B.	Murata		
	C2012X7R2A102K	TDK		
C6,C7 OR	C4532X7R2A225K	TDK	2.2 μ F/100V,1812, Ceramic capacitor	2
	GRM32ER72A225KA35L.	Murata	2.2uF/100V, 2220, Ceramic capacitor	
C4 OR	VJ0603Y103KXBAT.	Vishay Vitramon	10nF/50V, 0603, Ceramic capacitor	1
	GRM188R71H103KA01D.	Murata		
R1,R8	CRCW0603100KFKEA.	Vishay Dale	100k Ω , 0603, 1%	2
R3	CRCW06030000FKEA.	Vishay Dale	0 Ω , 0603	1
R4	CRCW20102R00FKEF	Vishay Dale	2 Ω , 1/2W, 2010	1
R9	CRCW06032K00FKEA.	Vishay Dale	2k Ω , 0805	1
R5	CRCW12064990FKEA.	Vishay Dale	499 Ω , 1206	1
R6	WSL2010-R0750-FKEA	Vishay Dale	0.075 Ω , 1/2W, 1812	1
R7	CRCW1206R620JNTALR.	Vishay Dale	0.620 Ω , 1/4W, 1206	1
R10			Open	1

Notes:

1. DigiKey: www.digikey.com
2. Murata: www.murata.com
3. Vishay: www.vishay.com
4. AVX: www.avx.com
5. TDK: www.tdk.com
6. Diodes, Inc.: www.diodes.com
7. Sumida: www.sumida.com
8. International Rectifier: www.irf.com
9. Micrel, Inc: www.micrel.com

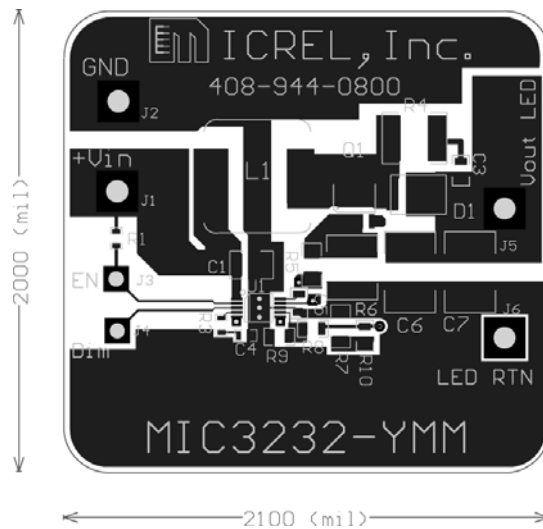
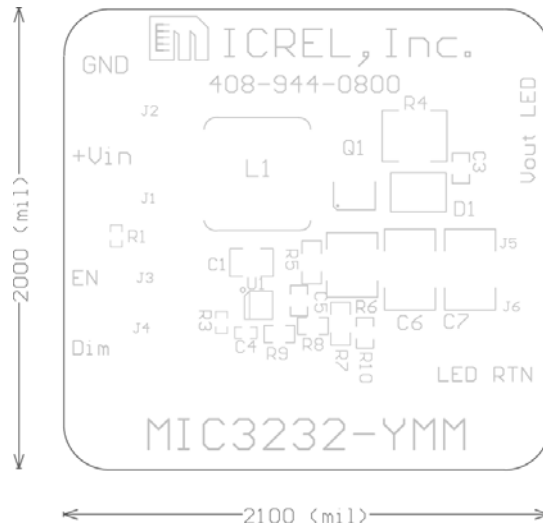

Top Layer

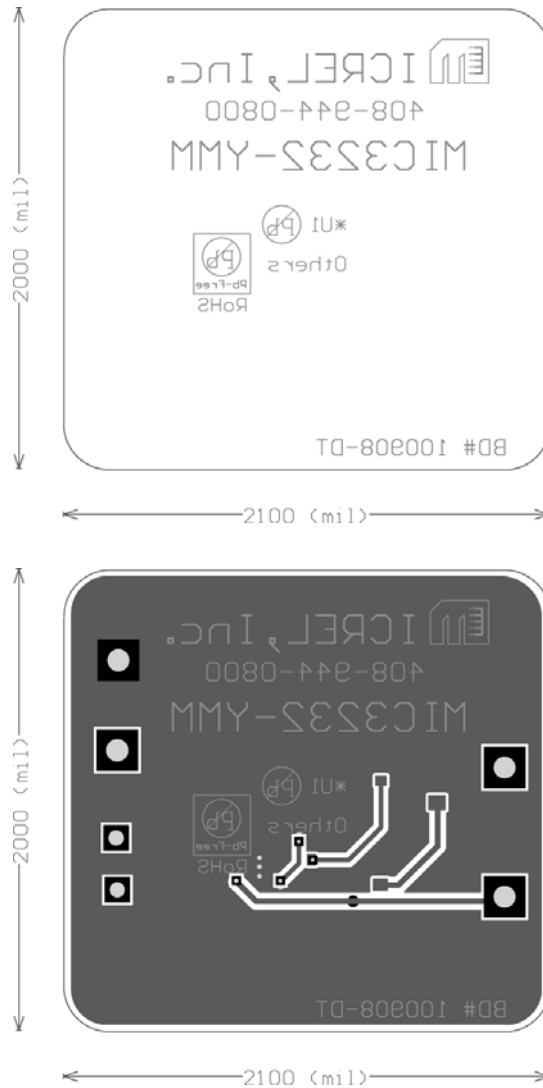

Bottom Layer

MICREL, INC. 2180 FORTUNE DRIVE SAN JOSE, CA 95131 USA
 TEL +1 (408) 944-0800 FAX +1 (408) 474-1000 WEB <http://www.micrel.com>

The information furnished by Micrel in this data sheet is believed to be accurate and reliable. However, no responsibility is assumed by Micrel for its use. Micrel reserves the right to change circuitry and specifications at any time without notification to the customer.

Micrel Products are not designed or authorized for use as components in life support appliances, devices or systems where malfunction of a product can reasonably be expected to result in personal injury. Life support devices or systems are devices or systems that (a) are intended for surgical implant into the body or (b) support or sustain life, and whose failure to perform can be reasonably expected to result in a significant injury to the user. A Purchaser's use or sale of Micrel Products for use in life support appliances, devices or systems is a Purchaser's own risk and Purchaser agrees to fully indemnify Micrel for any damages resulting from such use or sale.

© 2009 Micrel, Incorporated.

X-ON Electronics

Largest Supplier of Electrical and Electronic Components

Click to view similar products for [LED Lighting Development Tools](#) category:

Click to view products by [Micrel](#) manufacturer:

Other Similar products are found below :

[MIC2870YFT EV](#) [TDGL014](#) [ISL97682IRTZEVALZ](#) [EA6358NH](#) [TPS92315EVM-516](#) [STEVAL-LLL006V1](#) [IS31LT3948-GRLS4-EB](#)
[104PW03F](#) [PIM526](#) [PIM527](#) [MAX6946EVKIT+](#) [MAX20070EVKIT#](#) [MAX20090BEVKIT#](#) [PIM498](#) [AP8800EV1](#) [ZXLD1370/1EV4](#)
[TLC59116EVM-390](#) [1216.1013](#) [TPS61176EVM-566](#) [TPS92001EVM-628](#) [1270](#) [1271.2004](#) [1272.1030](#) [1273.1010](#) [1278.1010](#) [1279.1002](#)
[1279.1001](#) [1282.1000](#) [1293.1900](#) [1293.1800](#) [1293.1700](#) [1293.1500](#) [1293.1100](#) [1282.1400](#) [1282.1100](#) [1293.1200](#) [1282.1200](#) [1293.1000](#)
[1282.6000](#) [1296.2012](#) [LM3423BBLSCSEV/NOPB](#) [LM3447-PAR-230VEVM](#) [LM3632EVM](#) [LP8861Q1EVM](#) [MIKROE-2520](#) [1721](#) [1762](#)
[PIR-GEVB](#) [TPS61161EVM-243](#) [TLC6C5712EVM](#)