



FEATURES

- 3.3V and 5V power supply options
- 500ps propagation delay
- Fully differential design
- Supports both standard and low voltage operation
- Available in 20-pin SOIC package

DESCRIPTION

The SY100EL90V is a triple ECL/LVECL-to-PECL/LVPECL translator. The device can translate over all combinations of supply voltages: -5V ECL to 5V PECL, -5V ECL to 3.3V LVPECL, -3.3V LVECL to 5V PECL or -3.3V LVECL to 3.3V LVPECL.

A V_{BB} output is provided for interfacing with single ended ECL signals at the input. If a single ended input is to be used, the V_{BB} output should be connected to the \bar{D} input. The active signal would then drive the D input. When used, the V_{BB} output should be bypassed to via a 0.01 μ F capacitor. The V_{BB} output is designed to act as the switching reference for the EL90V under single ended input switching conditions. As a result this pin can only source/sink up to 0.5mA of current.

To accomplish the level translation the EL90V requires three power rails. The V_{CC} supply should be connected to the positive supply, and the V_{EE} pin should be connected to the negative power supply. The GND pins as expected are connected to the system ground plane. Both V_{EE} and V_{CC} should be bypassed to ground via 0.01 μ F capacitors.

Under open input conditions, the \bar{D} input will be biased at $V_{CC}/2$ and the D input will be pulled to V_{EE} . This condition will force the Q output to a LOW, ensuring stability.

FUNCTION TABLE

Function	VCC	GND	VEE
-5V ECL to 5V PECL	5V	0V	-5V
-5V ECL to 3.3V LVPECL	3.3V	0V	-5V
-3.3V LVECL to 5V PECL	5V	0V	-3.3V
-3.3V LVECL to 3.3V LVPECL	3.3V	0V	-3.3V

PIN NAMES

Pin	Function
Dn	ECL/LVECL Inputs
Qn	PECL/LVPECL Outputs
VBB	ECL/LVECL Reference Voltage Output

PACKAGE/ORDERING INFORMATION

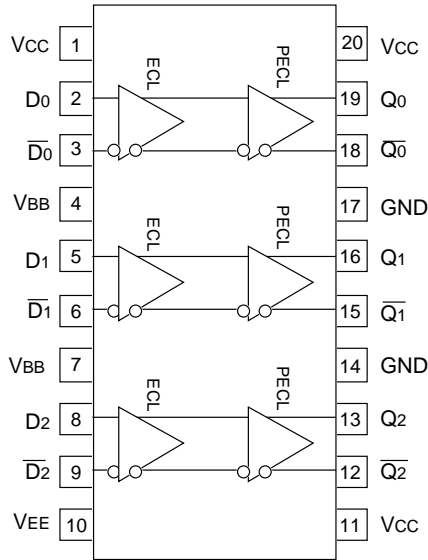

20-Pin Wide SOIC (Z20-1)

Ordering Information⁽¹⁾

Part Number	Package Type	Operating Range	Package Marking	Lead Finish
SY100EL90VZC	Z20-1	Commercial	SY100EL90VZC	Sn-Pb
SY100EL90VZCTR ⁽²⁾	Z20-1	Commercial	SY100EL90VZC	Sn-Pb
SY100EL90VZI	Z20-1	Industrial	SY100EL90VZI	Sn-Pb
SY100EL90VZITR ⁽²⁾	Z20-1	Industrial	SY100EL90VZI	Sn-Pb
SY100EL90VZG ⁽³⁾	Z20-1	Industrial	SY100EL90VZG with Pb-Free bar-line indicator	NiPdAu Pb-Free
SY100EL90VZGTR ^(2, 3)	Z20-1	Industrial	SY100EL90VZG with Pb-Free bar-line indicator	NiPdAu Pb-Free

Notes:

1. Contact factory for die availability. Dice are guaranteed at $T_A = 25^\circ\text{C}$, DC Electricals only.
2. Tape and Reel.
3. Pb-Free package is recommended for new designs.

ECL/LVECL INPUT DC ELECTRICAL CHARACTERISTICSECL: $V_{EE} = -4.2V$ to $-5.5V$; LVECL: $V_{EE} = -3.0V$ to $-3.8V$

Symbol	Parameter	$T_A = -40^\circ C$			$T_A = 0^\circ C$			$T_A = +25^\circ C$			$T_A = +85^\circ C$			Unit
		Min.	Typ.	Max.	Min.	Typ.	Max.	Min.	Typ.	Max.	Min.	Typ.	Max.	
V_{IH}	Input HIGH Voltage	-1165	—	-880	-1165	—	-880	-1165	—	-880	-1165	—	-880	mV
V_{IL}	Input LOW Voltage	-1810	—	-1475	-1810	—	-1475	-1810	—	-1475	-1810	—	-1475	mV
I_{EE}	Power Supply Current	—	—	8	—	—	8	—	—	8	—	—	8	mA
I_{IH}	Input HIGH Current	—	—	150	—	—	150	—	—	150	—	—	150	μA
I_{IL}	Input LOW Current D_n $\overline{D_n}$	0.5 -600	— —	— —	0.5 -600	— —	— —	0.5 -600	— —	— —	0.5 -600	— —	— —	μA
V_{BB}	Output Reference	-1.38	—	-1.26	-1.38	—	-1.26	-1.38	—	-1.26	-1.38	—	-1.26	V
V_{PP}	Minimum Peak-to-Peak Input	150	—	—	150	—	—	150	—	—	150	—	—	mV

LVPECL OUTPUT DC ELECTRICAL CHARACTERISTICS $V_{CC} = +3.0V$ to $+3.8V$

Symbol	Parameter	$T_A = -40^\circ C$			$T_A = 0^\circ C$			$T_A = +25^\circ C$			$T_A = +85^\circ C$			Unit
		Min.	Typ.	Max.	Min.	Typ.	Max.	Min.	Typ.	Max.	Min.	Typ.	Max.	
V_{OH}	Output HIGH Voltage ⁽¹⁾	2.215	—	2.420	2.275	—	2.420	2.275	2.350	2.420	2.275	—	2.420	V
V_{OL}	Output LOW Voltage ⁽¹⁾	1.470	—	1.745	1.490	—	1.680	1.490	1.600	1.680	1.490	—	1.680	V
I_{CC}	Power Supply Current	—	—	24	—	—	24	—	20	24	—	—	26	mA

Note:1. These levels are for $V_{CC} = 3.3V$. Level specifications will vary 1:1 with V_{CC} .**PECL OUTPUT DC ELECTRICAL CHARACTERISTICS** $V_{CC} = +4.2V$ to $+5.5V$

Symbol	Parameter	$T_A = -40^\circ C$			$T_A = 0^\circ C$			$T_A = +25^\circ C$			$T_A = +85^\circ C$			Unit
		Min.	Typ.	Max.	Min.	Typ.	Max.	Min.	Typ.	Max.	Min.	Typ.	Max.	
V_{OH}	Output HIGH Voltage ⁽¹⁾	3.915	—	4.120	3.975	—	4.120	3.975	4.050	4.120	3.975	—	4.120	V
V_{OL}	Output LOW Voltage ⁽¹⁾	3.170	—	3.445	3.190	—	3.380	3.190	3.300	3.380	3.190	—	3.380	V
I_{CC}	Power Supply Current	—	—	24	—	—	24	—	20	24	—	—	26	mA

Note:1. These values are for $V_{CC} = 5V$. Level specifications will vary 1:1 with V_{CC} .

AC ELECTRICAL CHARACTERISTICS

ECL: $V_{EE} = -4.2V$ to $-5.5V$; LVECL: $V_{EE} = -3.0V$ to $-3.8V$; PECL: $V_{CC} = +4.2V$ to $+5.5V$; LVPECL: $V_{CC} = +3.0V$ to $+3.8V$

Symbol	Parameter	$T_A = -40^\circ C$			$T_A = 0^\circ C$			$T_A = +25^\circ C$			$T_A = +85^\circ C$			Unit	
		Min.	Typ.	Max.	Min.	Typ.	Max.	Min.	Typ.	Max.	Min.	Typ.	Max.		
t_{PD}	Propagation Delay D to Q	Diff.	390	—	590	410	—	610	420	—	620	460	—	660	ps
		S.E.	340	—	640	360	—	660	370	—	670	410	—	710	
t_{skew}	Within-Device Skew ⁽¹⁾	—	20	100	—	20	100	—	20	100	—	20	100	ps	
	Output-to-Output	—	—	200	—	—	200	—	—	200	—	—	200		
	Part-to-Part (Diff.) Duty Cycle (Diff.)	—	25	—	—	25	—	—	25	—	—	25	—		
V_{PP}	Minimum Input Swing ⁽²⁾	150	—	—	150	—	—	150	—	—	150	—	—	mV	
V_{CMR}	Common Mode Range ⁽³⁾	—	—	-0.4	—	—	-0.4	—	—	-0.4	—	—	-0.4	V	
t_r t_f	Output Rise/Fall Times Q (20% to 80%)	230	—	500	230	—	500	230	—	500	230	—	500	ps	

Notes:

- Skew is measured between outputs under identical transitions.
- Minimum input swing for which AC parameters are guaranteed. The device will function reliably with differential inputs down to 100mV.
- The CMR range is referenced to the most positive side of the differential input signal. Normal operation is obtained if the HIGH level falls within the specified range and the peak-to-peak voltage lies between V_{PP} min. and 1V. V_{CMR} min. depends on V_{EE} , V_{PP} and temperature at $V_{PP} < 500mV$ and $-40^\circ C$, V_{CMR} is $V_{EE}+1.3V$; and for $0-85^\circ C$, V_{CMR} is $V_{EE}+1.2V$. At $V_{PP} \geq 500mV$ and $-40^\circ C$, V_{CMR} is $V_{EE}+1.5V$; and for $0-85^\circ C$, V_{CMR} is $V_{EE}+1.4V$.

20-PIN SOIC .300" WIDE (Z20-1)

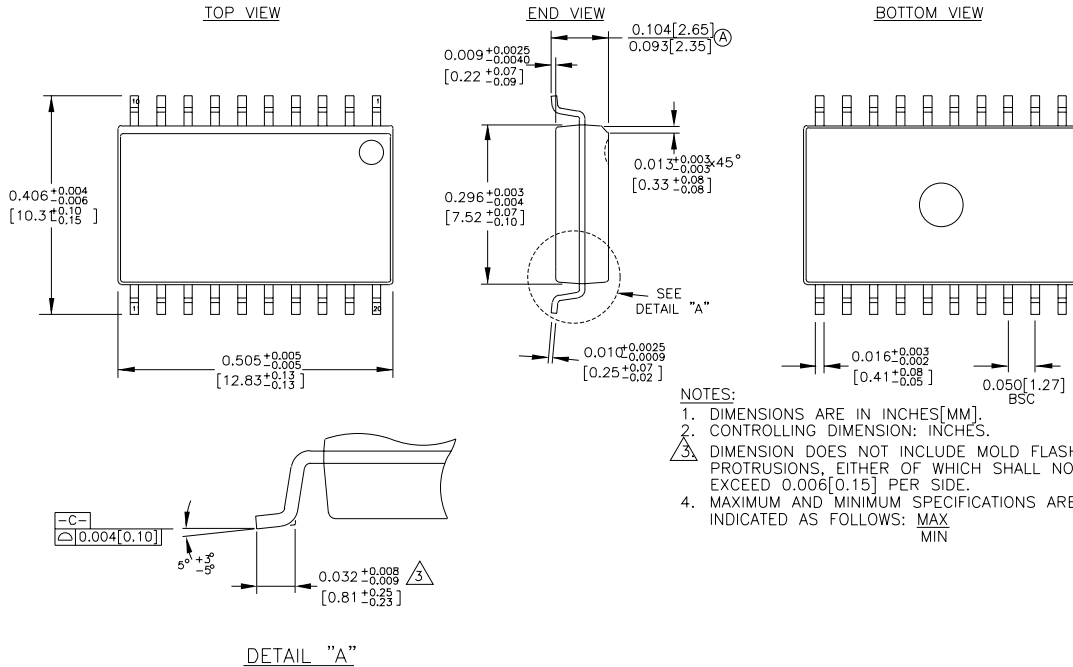

Rev. 03

MICREL, INC. 2180 FORTUNE DRIVE SAN JOSE, CA 95131 USA

TEL + 1 (408) 944-0800 FAX + 1 (408) 474-1000 WEB <http://www.micrel.com>

The information furnished by Micrel in this datasheet is believed to be accurate and reliable. However, no responsibility is assumed by Micrel for its use. Micrel reserves the right to change circuitry and specifications at any time without notification to the customer.

Micrel Products are not designed or authorized for use as components in life support appliances, devices or systems where malfunction of a product can reasonably be expected to result in personal injury. Life support devices or systems are devices or systems that (a) are intended for surgical implant into the body or (b) support or sustain life, and whose failure to perform can be reasonably expected to result in a significant injury to the user. A Purchaser's use or sale of Micrel Products for use in life support appliances, devices or systems is at Purchaser's own risk and Purchaser agrees to fully indemnify Micrel for any damages resulting from such use or sale.

© 2006 Micrel, Incorporated.

X-ON Electronics

Largest Supplier of Electrical and Electronic Components

Click to view similar products for [Translation - Voltage Levels](#) category:

Click to view products by [Micrel](#) manufacturer:

Other Similar products are found below :

[NLSX4373DMR2G](#) [NLSX5012MUTAG](#) [NLSX0102FCT2G](#) [NLSX4302EBMUTCG](#) [PCA9306FMUTAG](#) [MC100EPT622MNG](#)
[NLSX5011MUTCG](#) [NLV9306USG](#) [NLVSVX4014MUTAG](#) [NLSV4T3144MUTAG](#) [NLVSVX4373MUTAG](#) [MAX3371ELT+T](#)
[NLSX3013BFCT1G](#) [NLV7WBD3125USG](#) [NLSX3012DMR2G](#) [74AVCH1T45FZ4-7](#) [NLVSV1T244MUTBG](#) [74AVC1T45GS-Q100H](#)
[CLVC16T245MDGGREP](#) [MC10H124FNG](#) [CAVCB164245MDGGREP](#) [CD40109BPWR](#) [MC10H350FNG](#) [MC10H125FNG](#)
[MC100EPT21MNR4G](#) [MC100EP91DWG](#) [NLSV2T244MUTAG](#) [NLSX3013FCT1G](#) [NLSX5011AMX1TCG](#) [PCA9306USG](#)
[SN74GTL1655DGGR](#) [SN74AVCA406LZQSR](#) [NLSX4014DTR2G](#) [NLSX3018DTR2G](#) [LTC1045CN#PBF](#) [SY100EL92ZG](#)
[74AXP1T34GMH](#) [74AXP1T34GNH](#) [LSF0204DPWR](#) [PI4ULS3V204LE](#) [ADG3245BRUZ-REEL7](#) [ADG3123BRUZ](#) [ADG3245BRUZ](#)
[ADG3246BCPZ](#) [ADG3308BCPZ-REEL](#) [ADG3233BRJZ-REEL7](#) [ADG3233BRMZ](#) [ADG3242BRJZ-REEL7](#) [ADG3243BRJZ-REEL7](#)
[ADG3245BCPZ](#)